

# Assembly Instructions

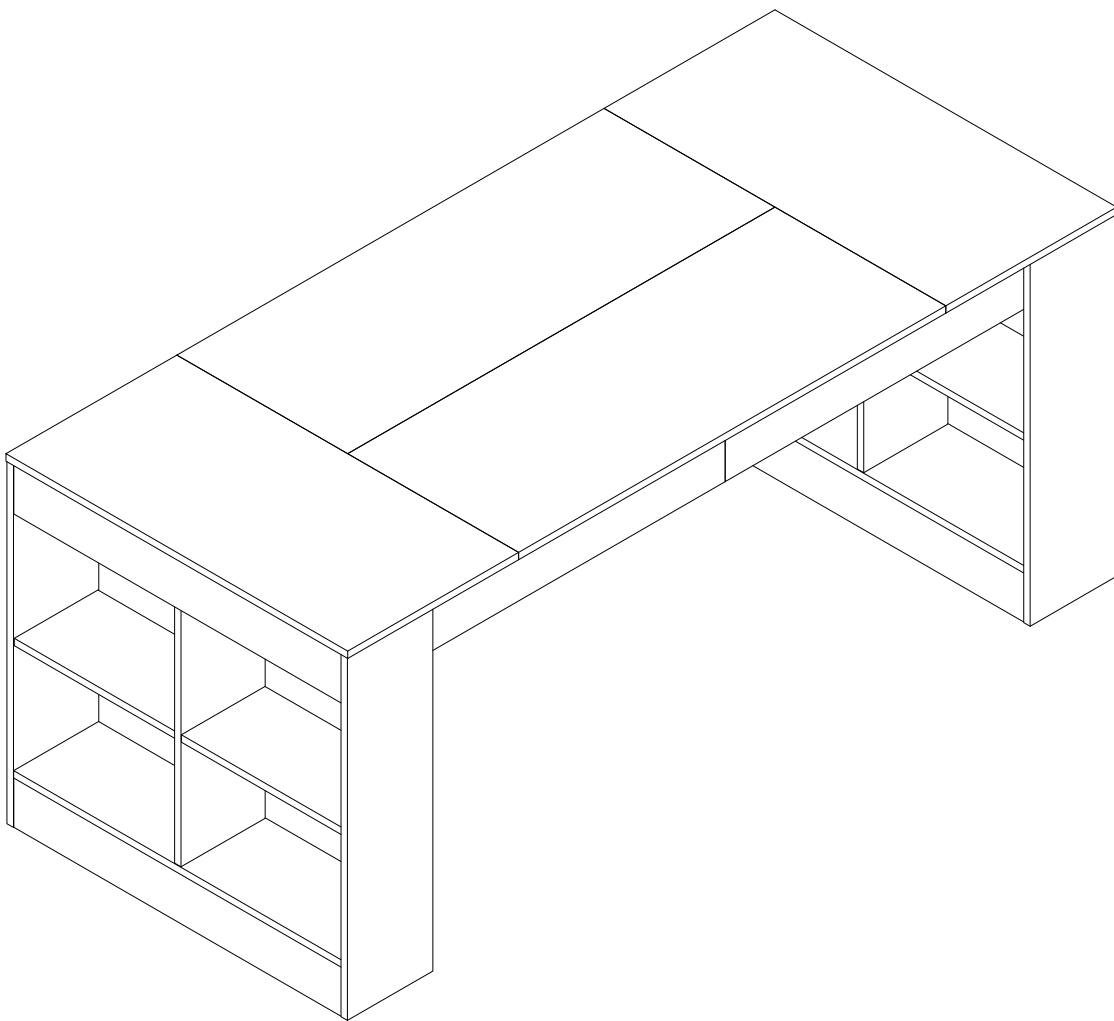

---

**Office Table**

Model No.  
**HOGA-GL0013**

---

# Contact Us

## We're here to help you.

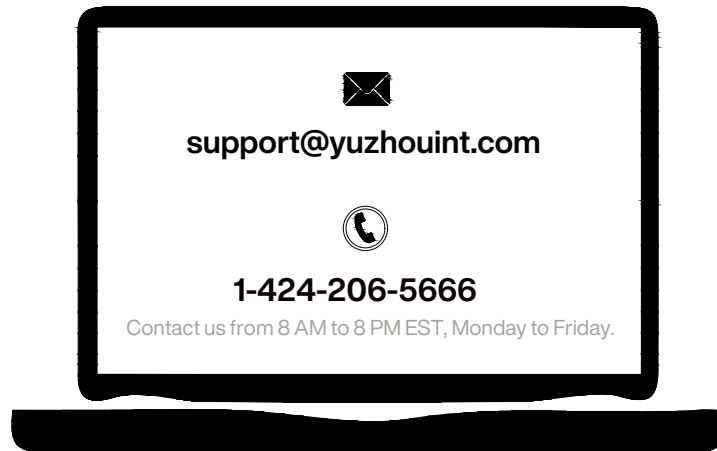

Your satisfaction is our top priority. If you encounter any issues with this product, such as missing or damaged parts, we're here to help. Please retain the original packaging and take photos of the packaging and the product, then contact us as soon as possible.

### Warm Tips

1. Carefully read these instructions and keep them for future reference.
2. Check the parts list and confirm everything's there before starting assembly.
3. When assembling, put all parts on a soft, smooth surface like a carpet to avoid scratches.
4. Don't fully tighten screws until all parts are confirmed in place to avoid misalignment.

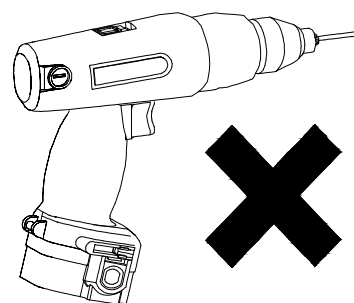
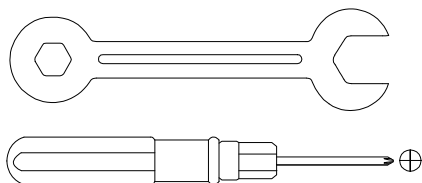
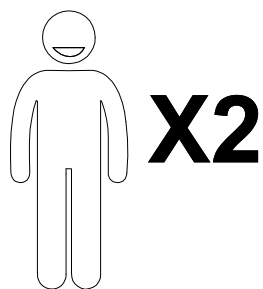

We recommend using hand tools for assembly.

If an electric screwdriver is used, reduce power and torque to avoid damage to the product.

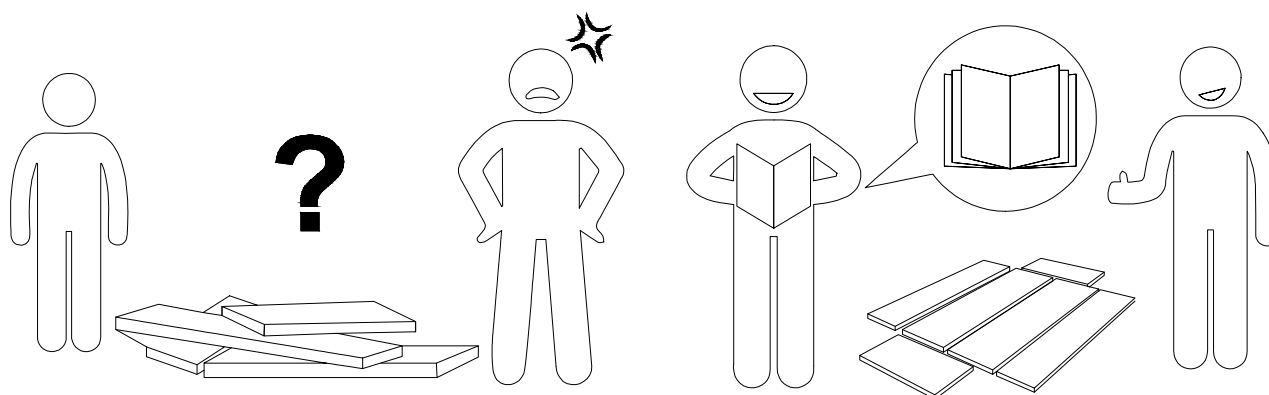

## AVOID SCRATCHES

In order to avoid scratching, this furniture should be assembled on a soft surface, such as a rug.

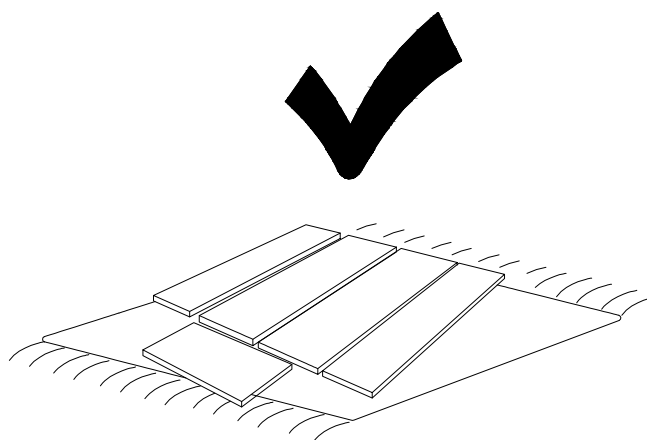
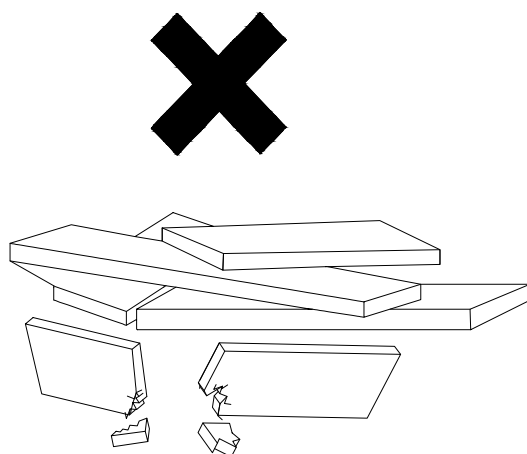

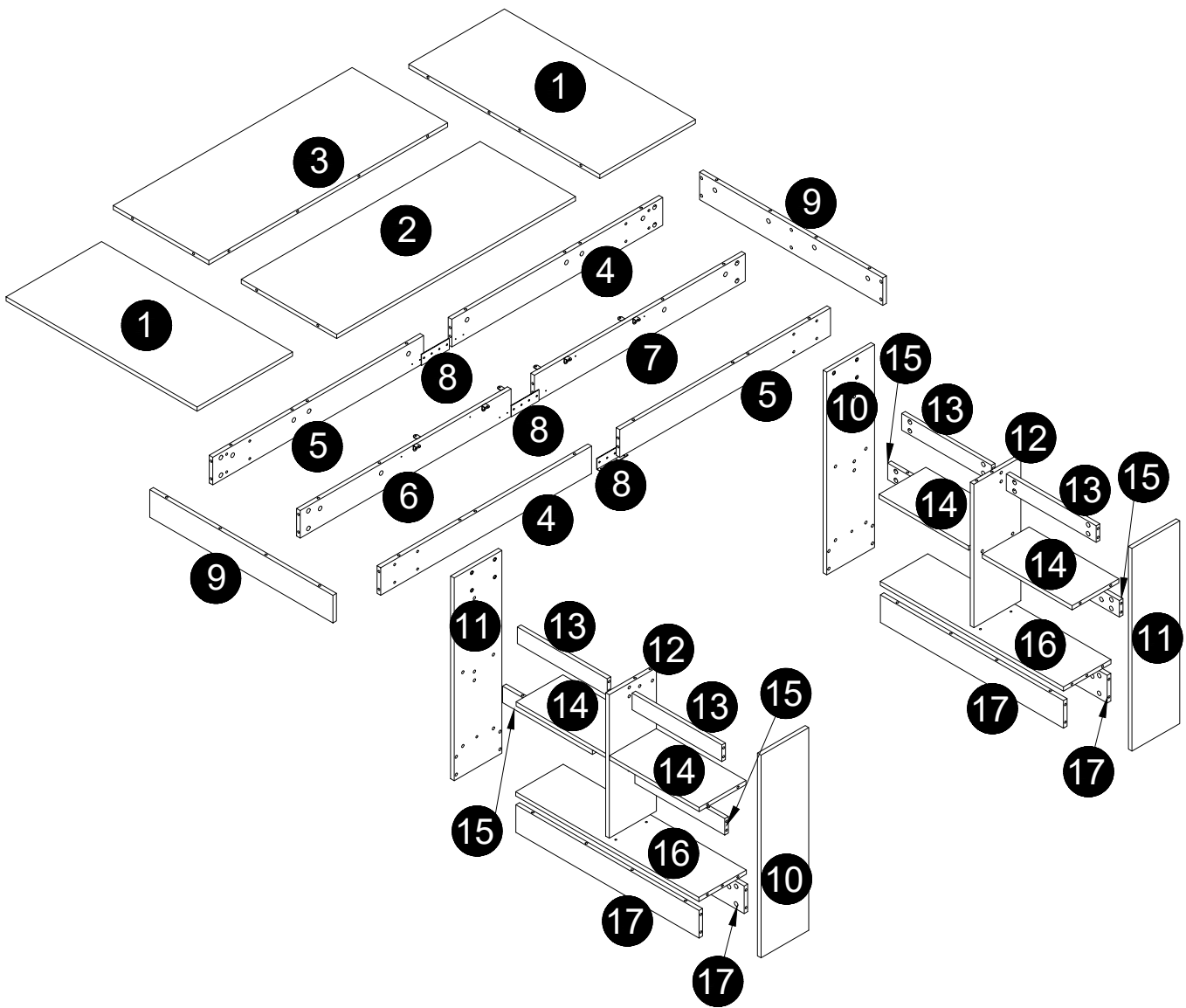



**⚠ Caution**

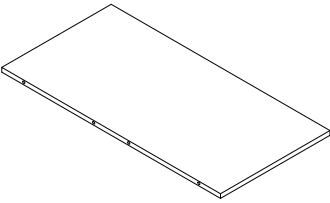
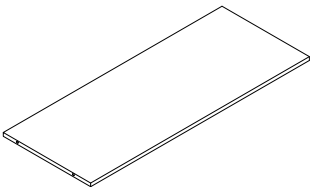
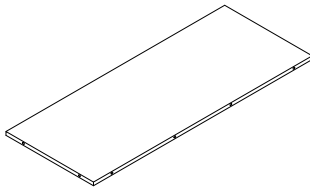
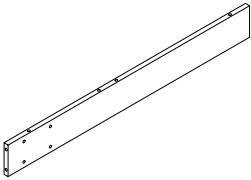
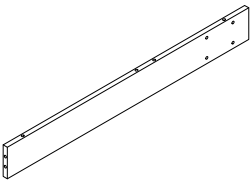
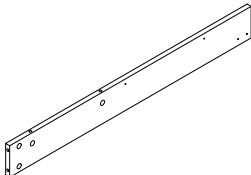
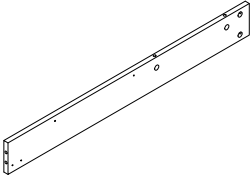
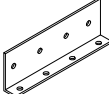
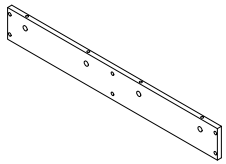

Make sure all parts are included. Most board parts are labeled or stamped on the raw edge. Contact us for a free replacement if you encounter any damaged or missing parts.

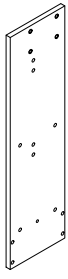
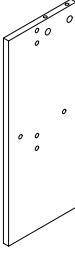
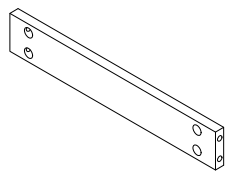
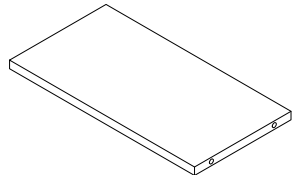
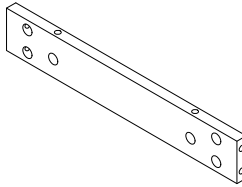
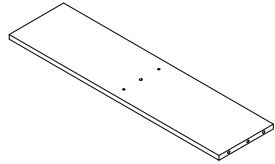
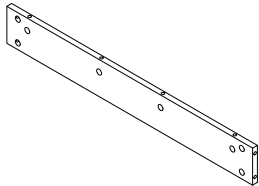

# Parts List

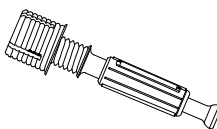
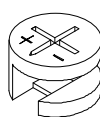
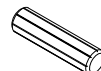
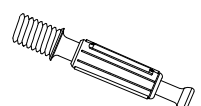
<b>1</b>  2 pcs	<b>2</b>  1 pc	<b>3</b>  1 pc	<b>4</b>  2 pcs
<b>5</b>  2 pcs	<b>6</b>  1 pc	<b>7</b>  1 pc	<b>8</b>  3 pcs
<b>9</b>  2 pcs	<b>10</b>  2 pcs	<b>11</b>  2 pcs	<b>12</b>  2 pcs
<b>13</b>  4 pcs	<b>14</b>  4 pcs	<b>15</b>  4 pcs	<b>16</b>  2 pcs
<b>17</b>  4 pcs			

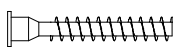
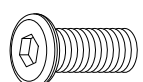
# Hardware List

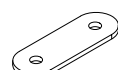
A	B	C	D
			
Ø6x40mm	Ø15x12mm	Ø7.8x30mm	Ø6x40mm
116 pcs	140 pcs	24 pcs	24 pcs

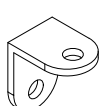
E	F	G	H
			
M5x40mm	M6x25mm	Ø3.5x14mm	47x16x2mm
4 pcs	16 pcs	56 pcs	8 pcs

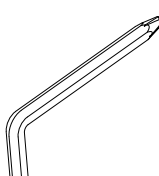
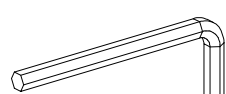
I	J	K	L
			
20x20x13mm	Ø14x4mm	M4	M3
8 pcs	8 pcs	1 pc	1 pc

## Installation of Cams and Pins

Step 1-2: Align the plastic part with the mounting hole and press it in. If you can't press it in, loosen the screw counter clockwise or completely remove the screw from the plastic part and try again.  
Step 3-4: After pressing the plastic part into place, use a screwdriver to tighten the screw clockwise.

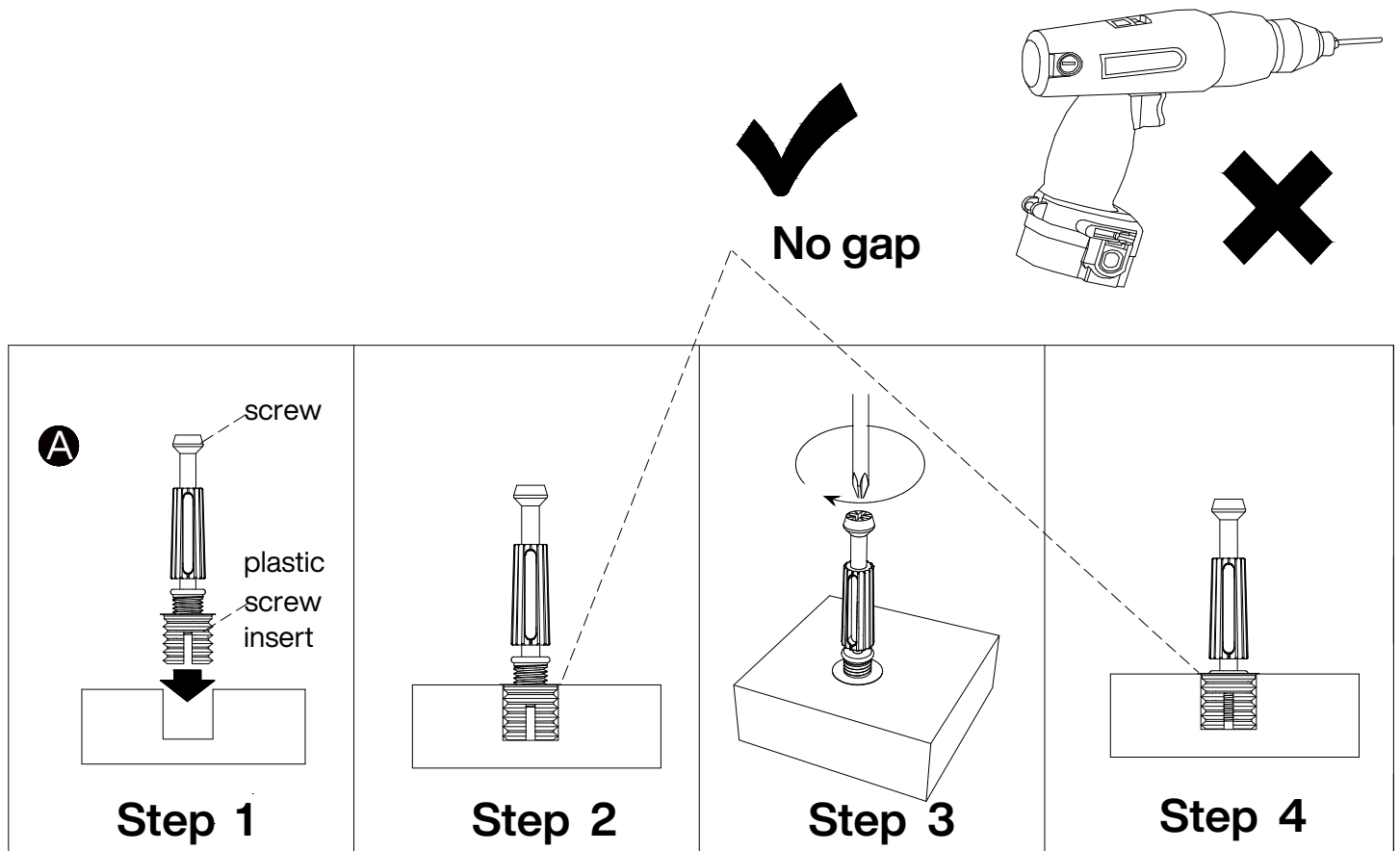

Screw the pin into the hole. Set the cams correctly by aligning the head of the cams with the lock pins. Lock the cam by turning the cam head with a screwdriver until it is tightened. Please do not use an electric screwdriver to assemble the unit.

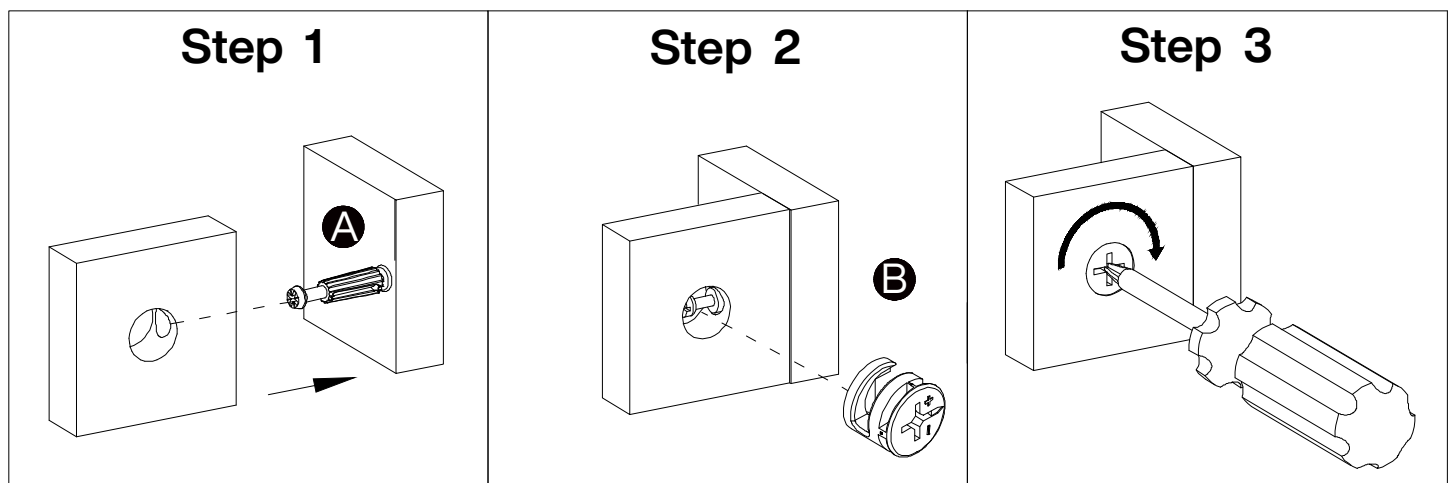

1

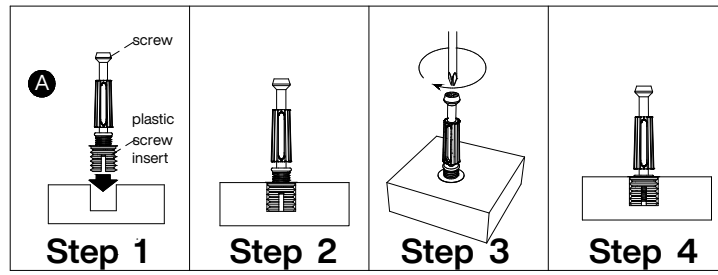

<b>A</b>

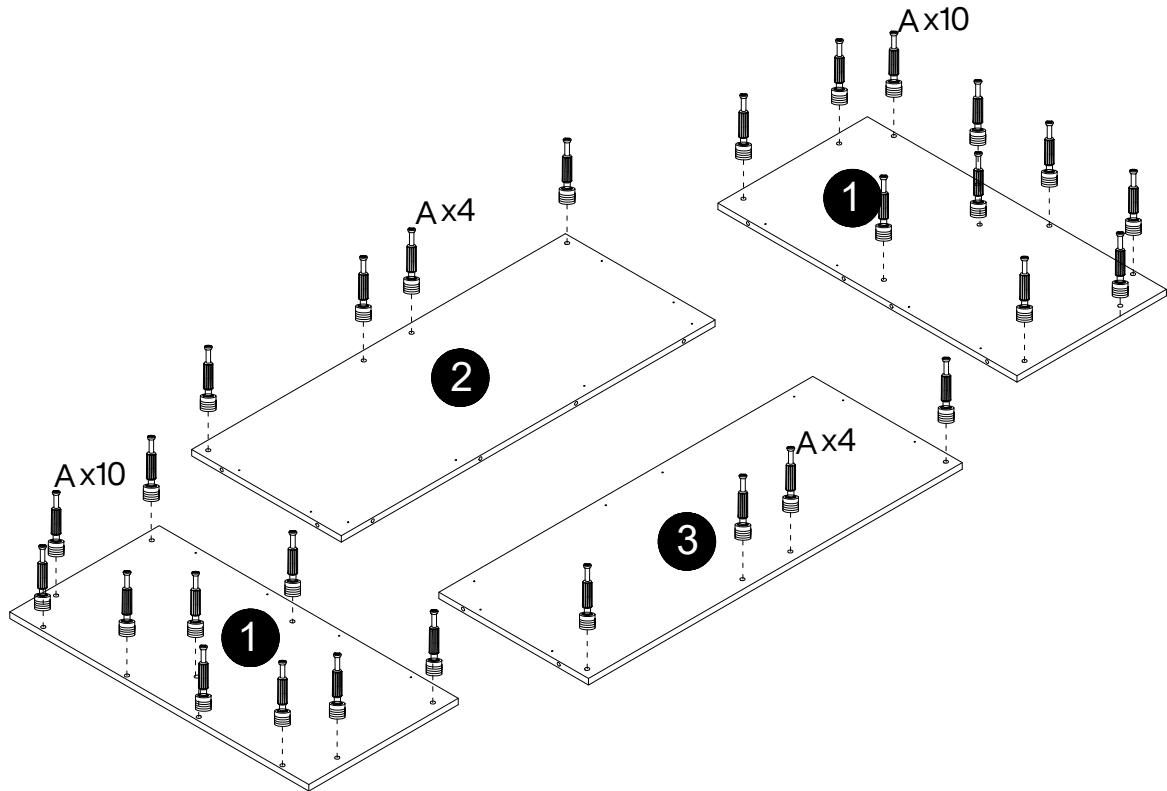
Ø6x40mm
28 pcs



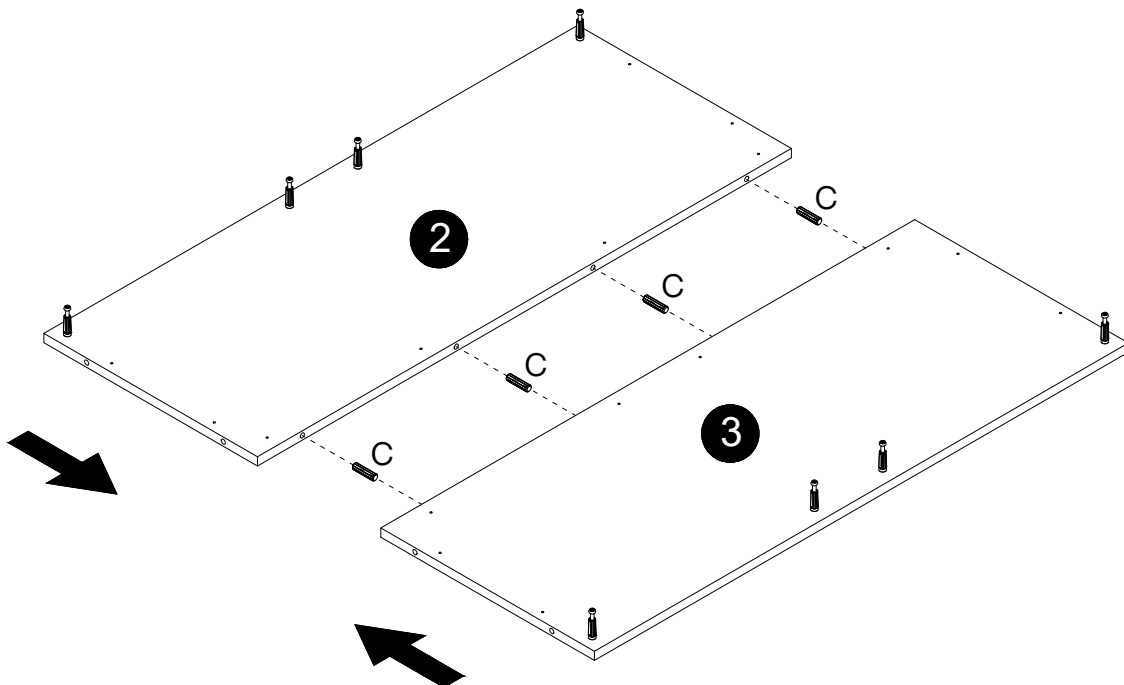

2

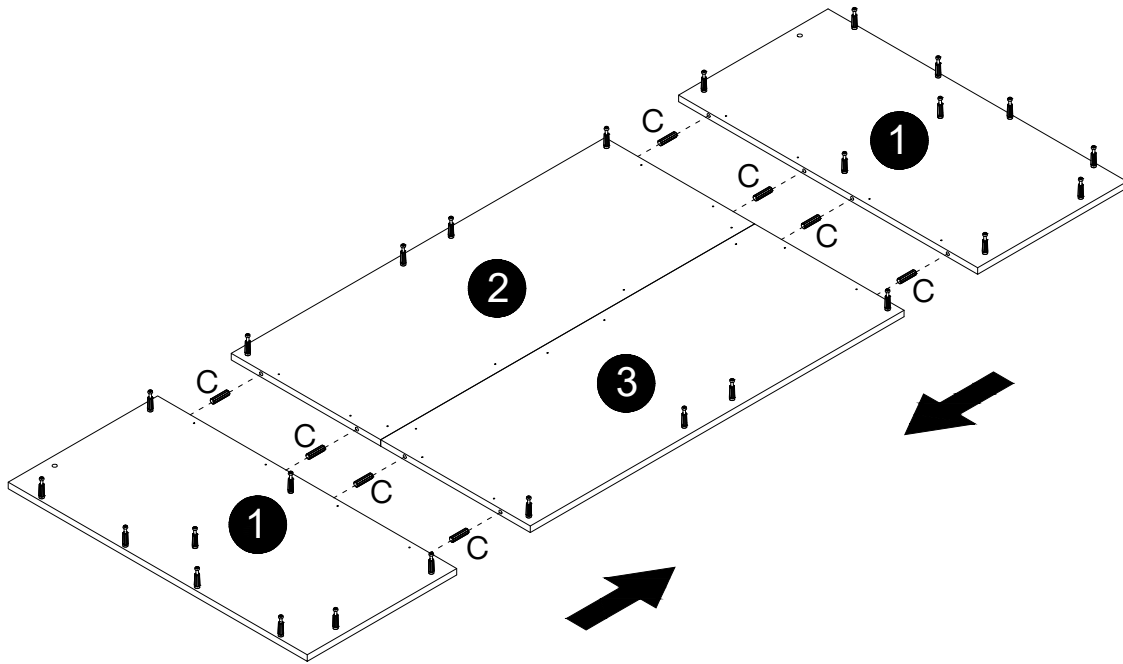

<b>C</b>

Ø7.8x30mm
4 pcs

3

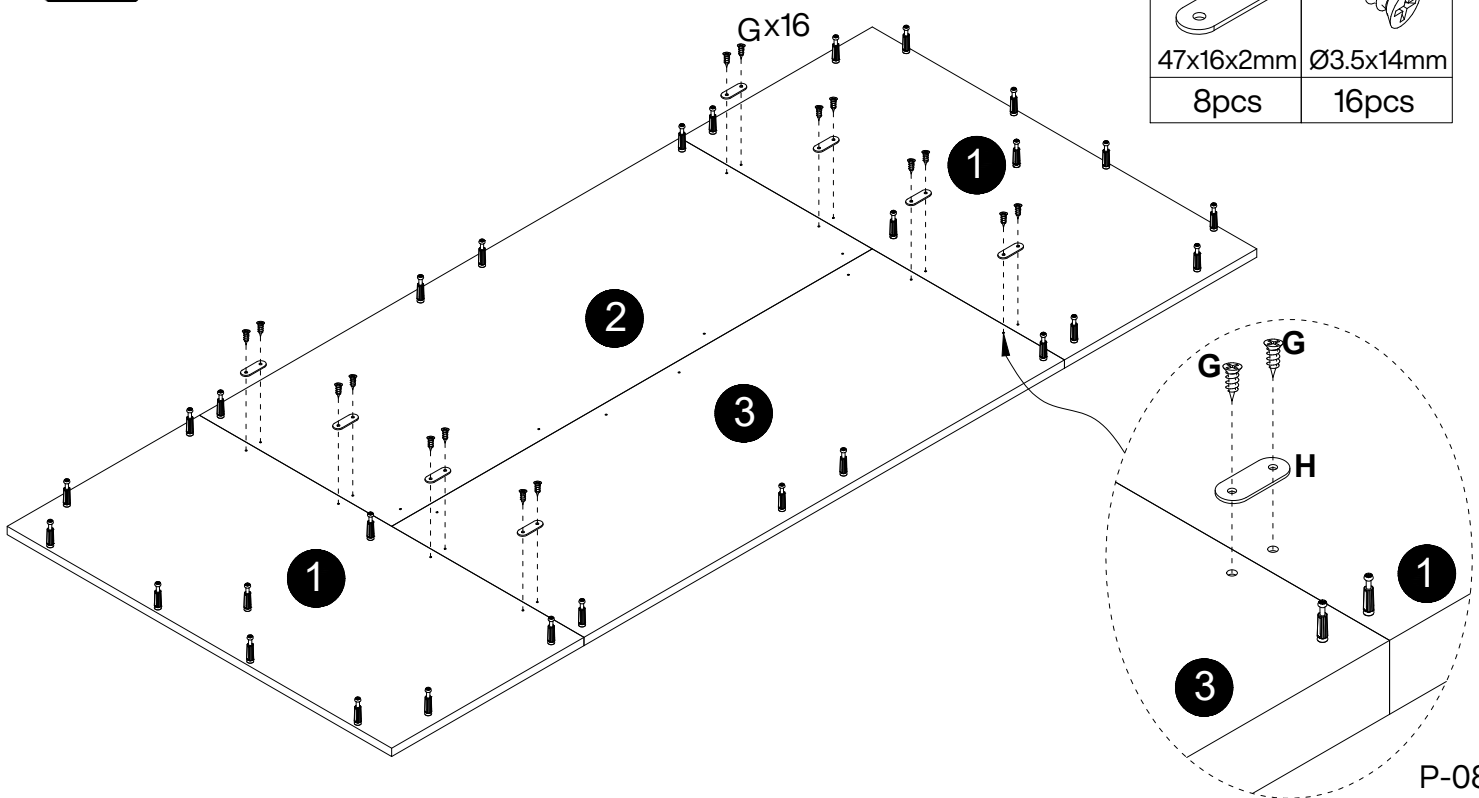

C

Ø7.8x30mm
8 pcs

4

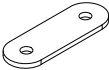
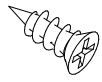

H	G
	
47x16x2mm	Ø3.5x14mm
8 pcs	16 pcs

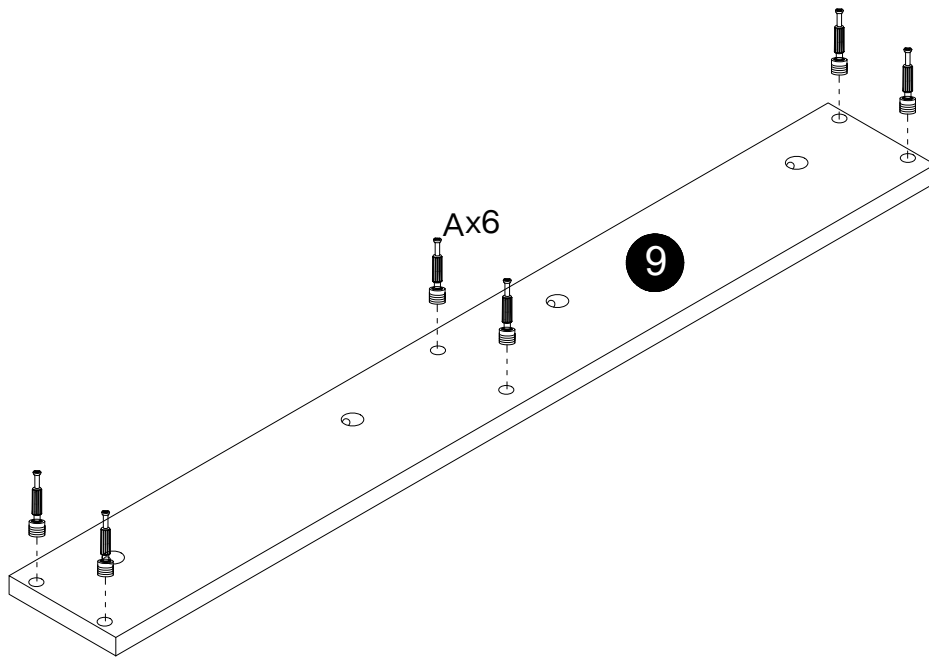
5



<b>A</b>

Ø6x40mm
12 pcs

x2

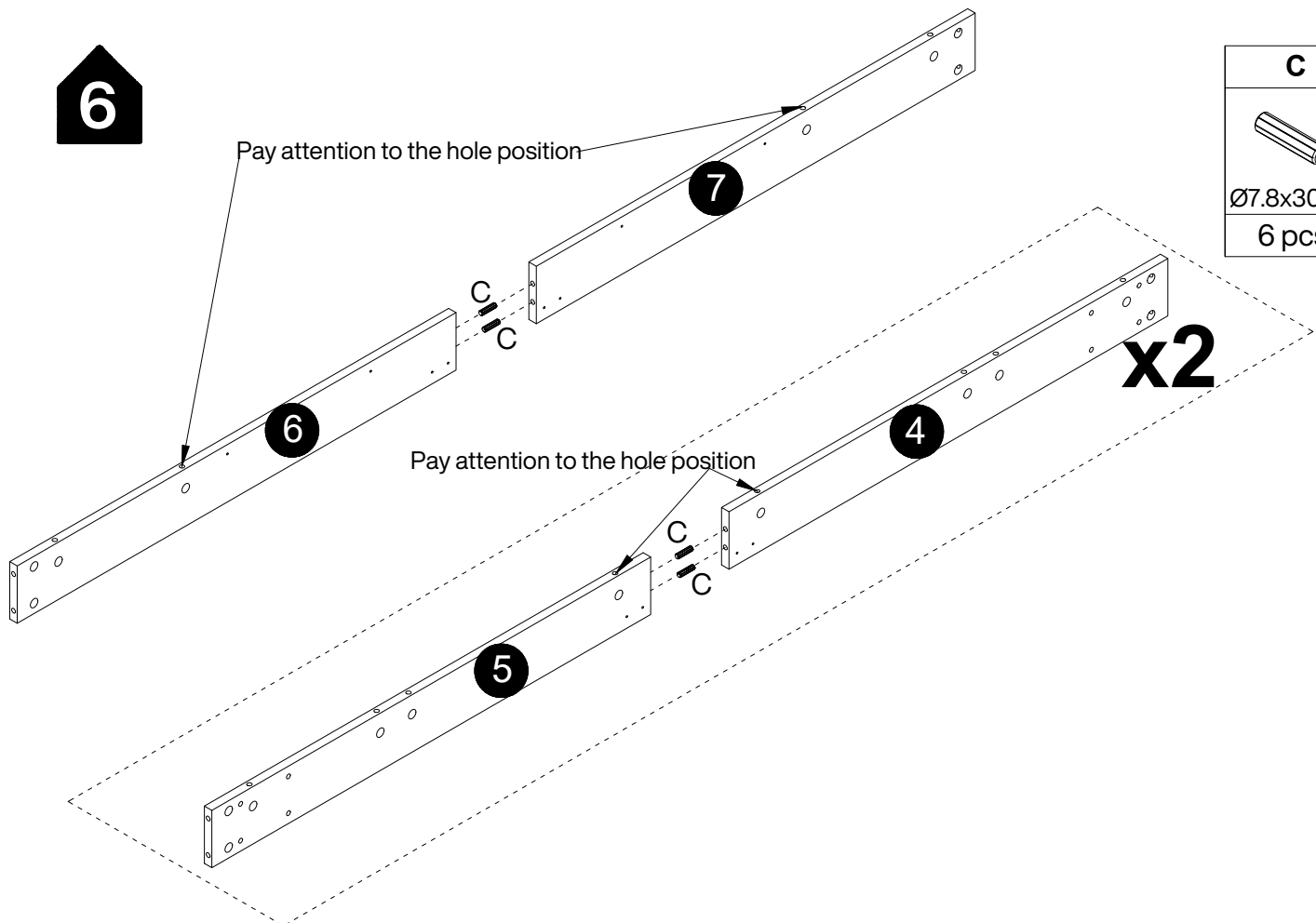
6



<b>C</b>

Ø7.8x30mm
6 pcs

x2

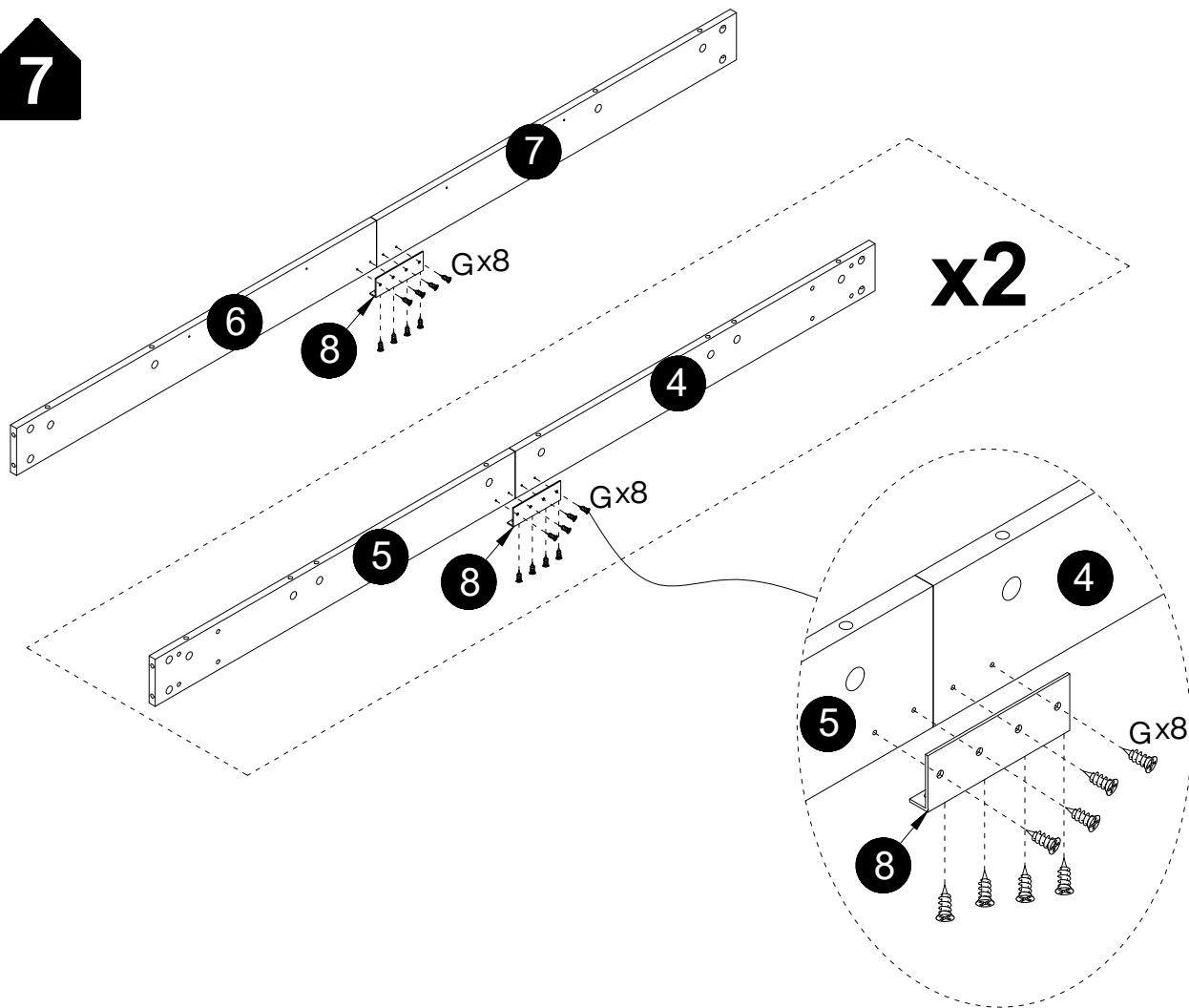
7



<b>G</b>

Ø3.5x14mm
24 pcs

8

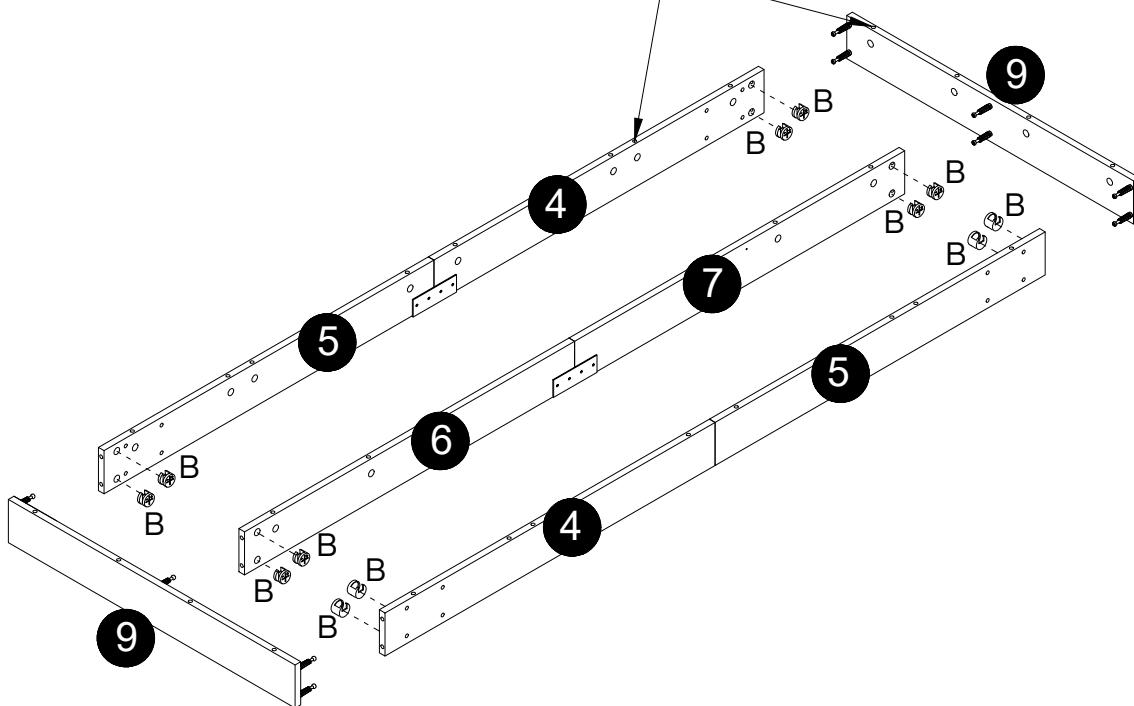
Pay attention to the hole position

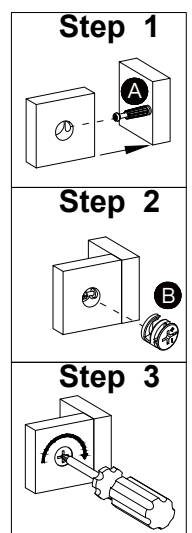

<b>B</b>

Ø15x12mm
12 pcs

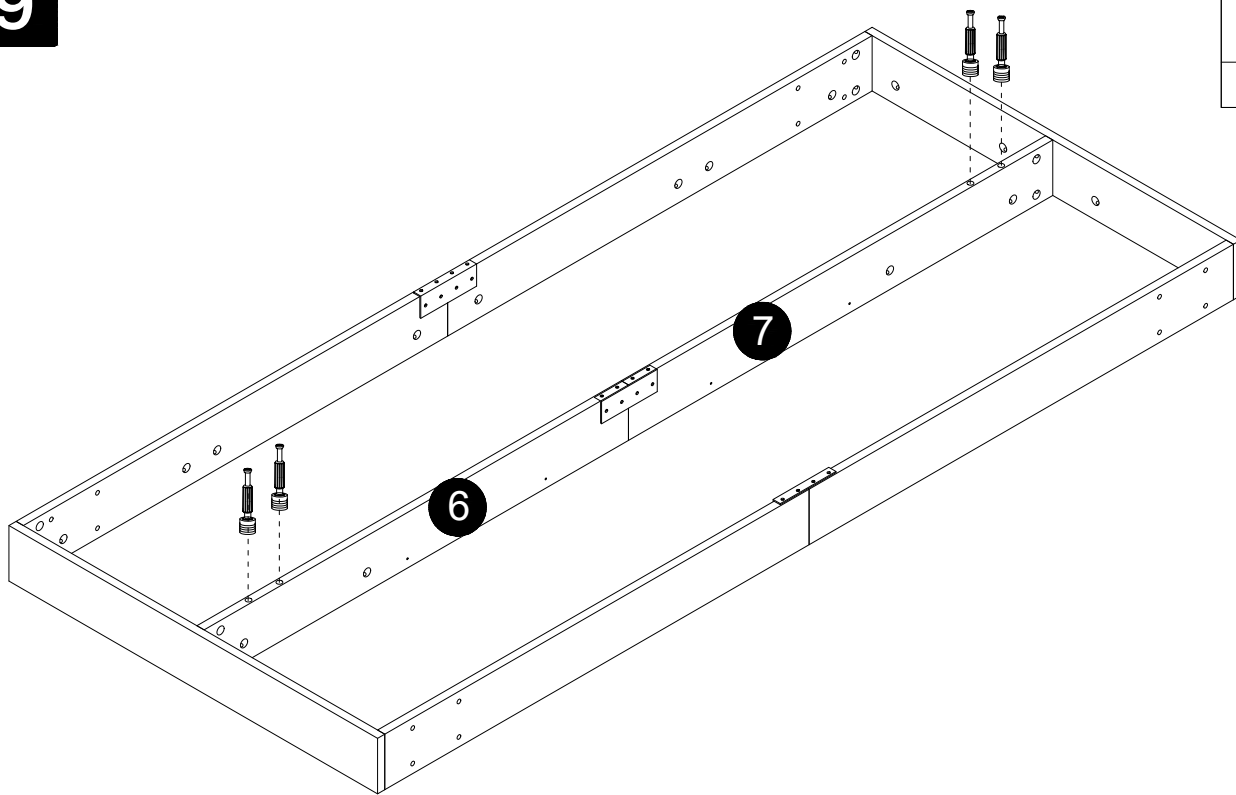

9

<b>A</b>

Ø6x40mm
4 pcs



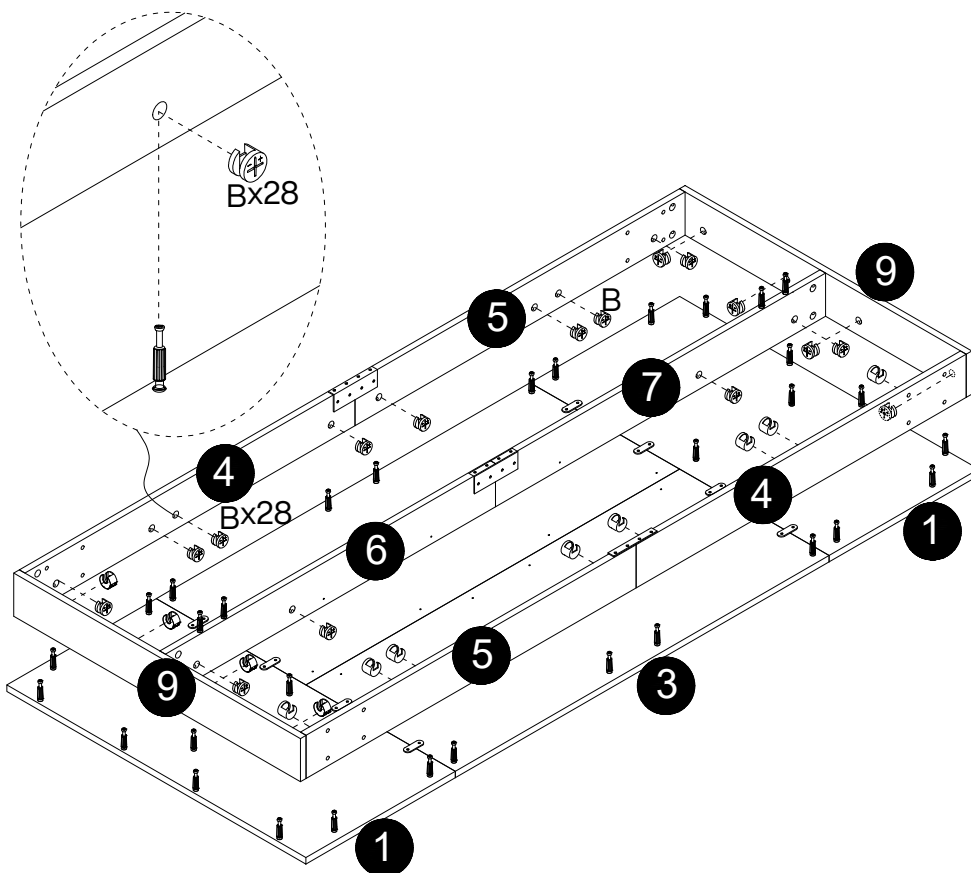

10

<b>B</b>

Ø15x12mm
28 pcs

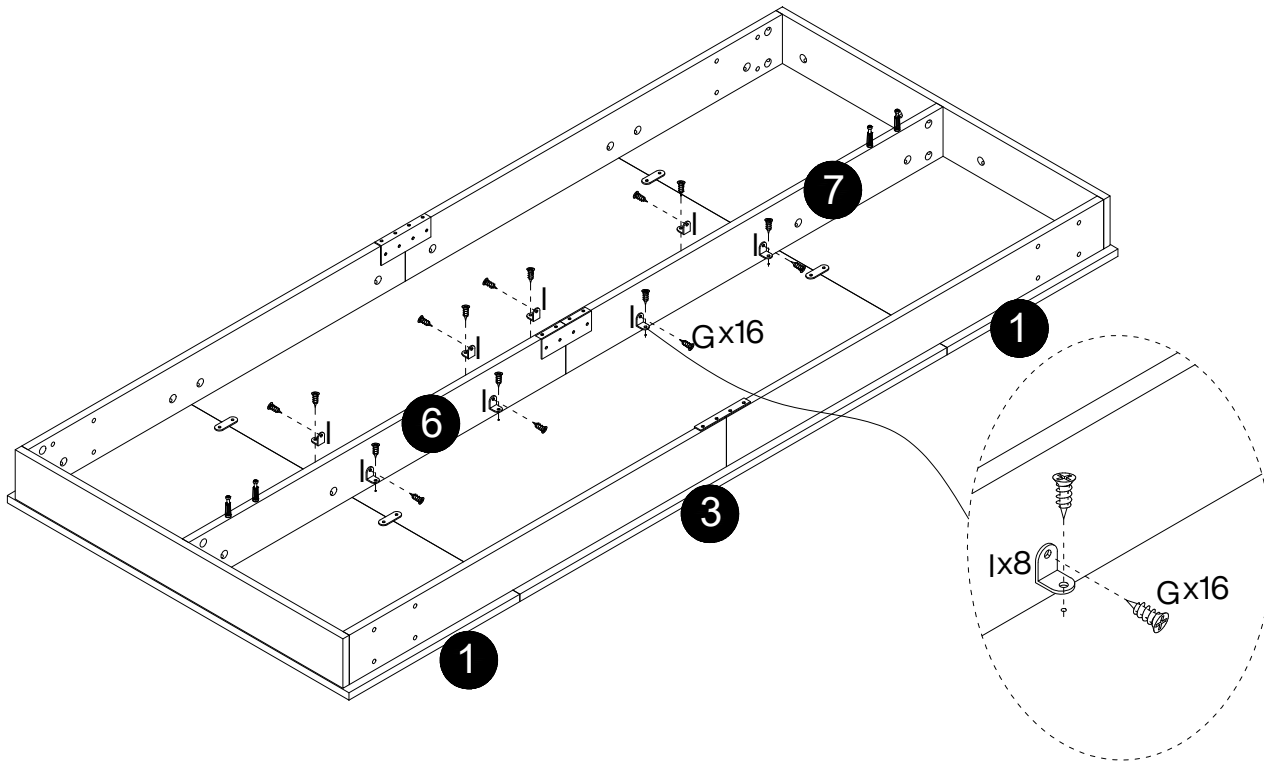

11

I	G
	
20x20x13mm	Ø3.5x14mm
8 pcs	16 pcs



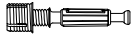

12

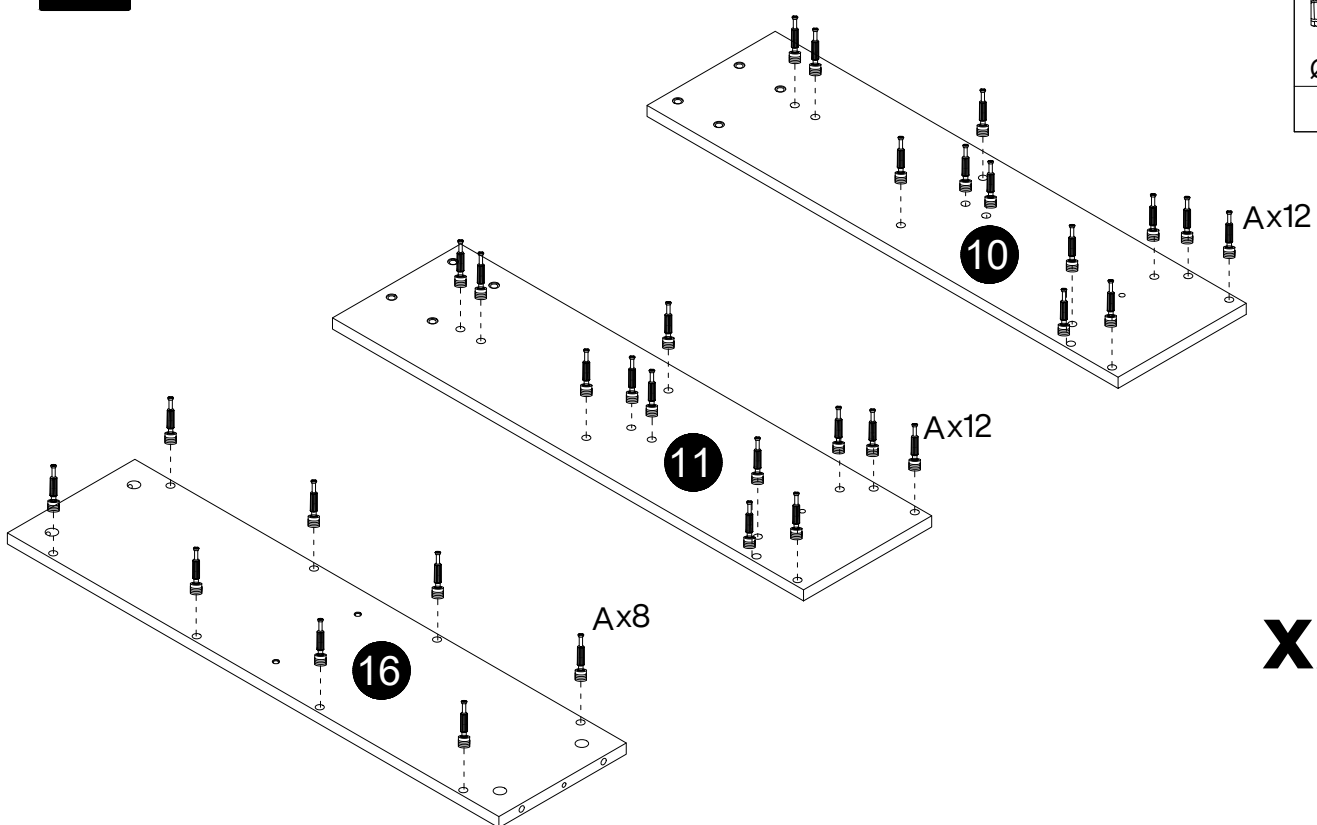
A

Ø6x40mm
64 pcs

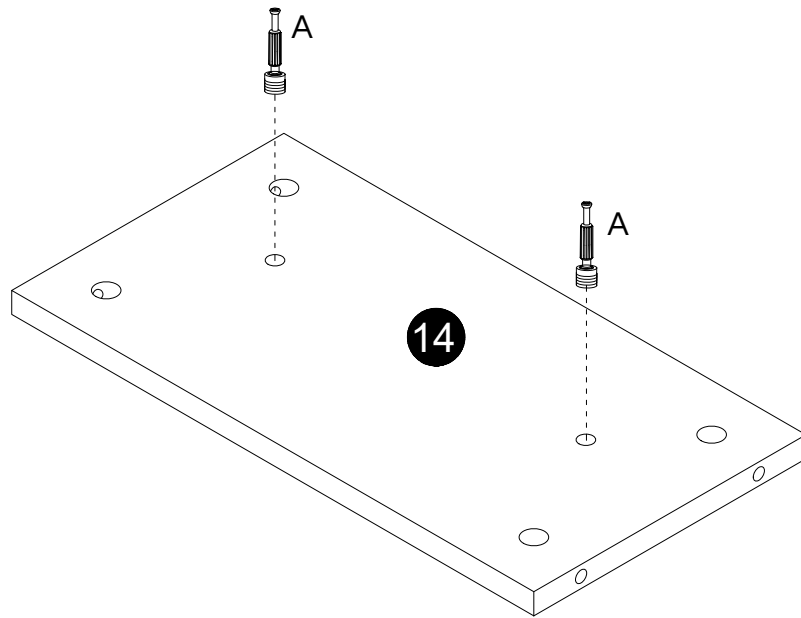

13



<b>A</b>

Ø6x40mm
8 pcs

x4

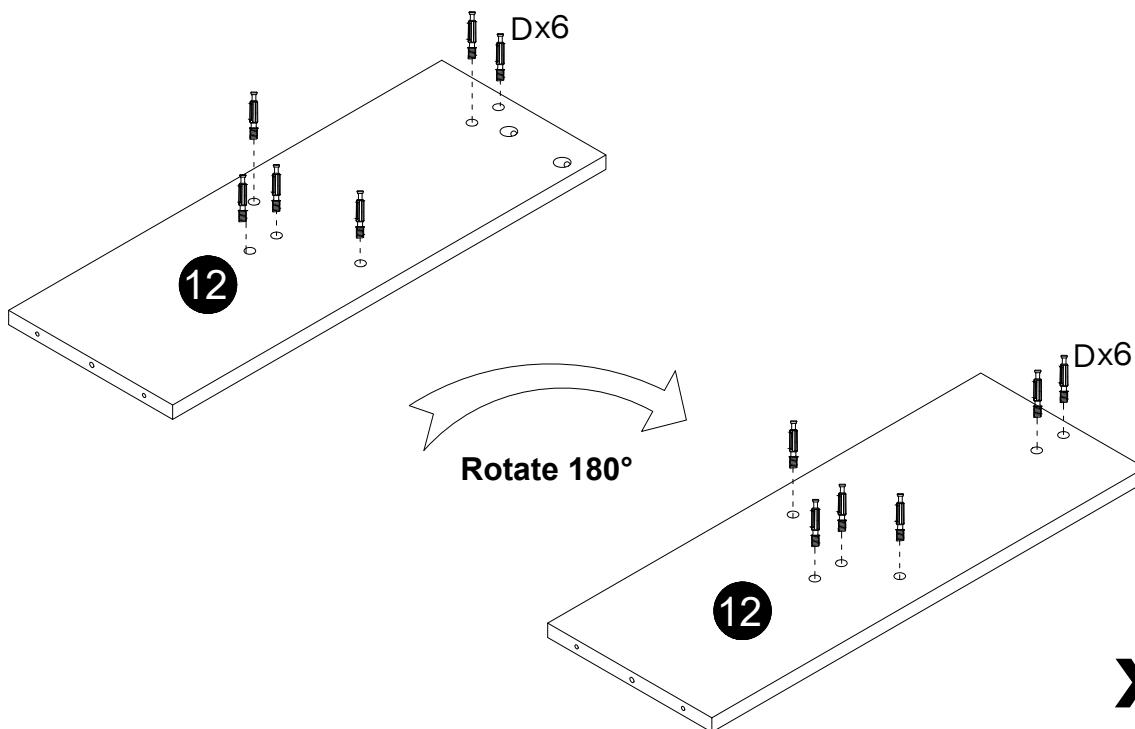
14



<b>D</b>

Ø6x40mm
24 pcs

x2

15

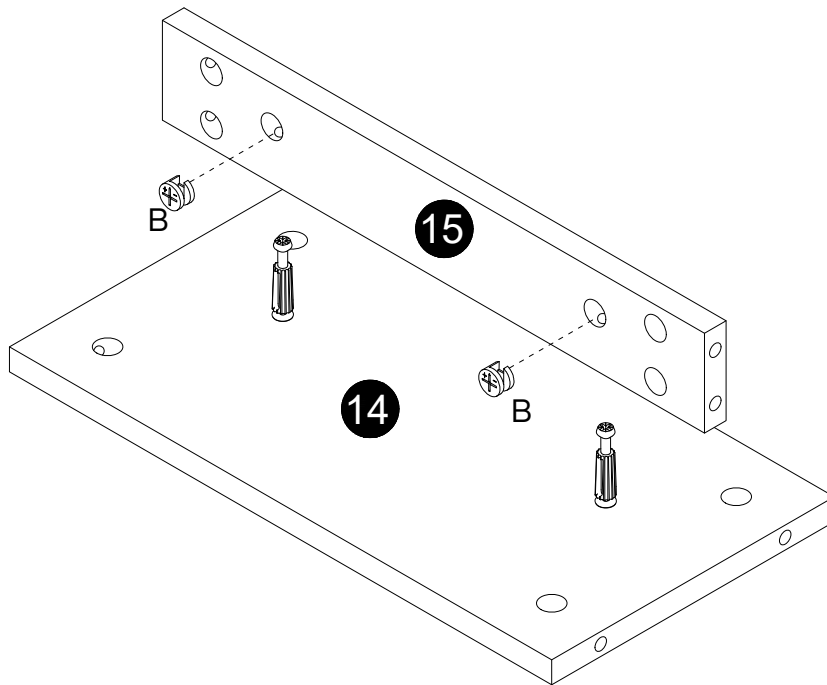
<b>B</b>

Ø15x12mm
8 pcs



x4

16

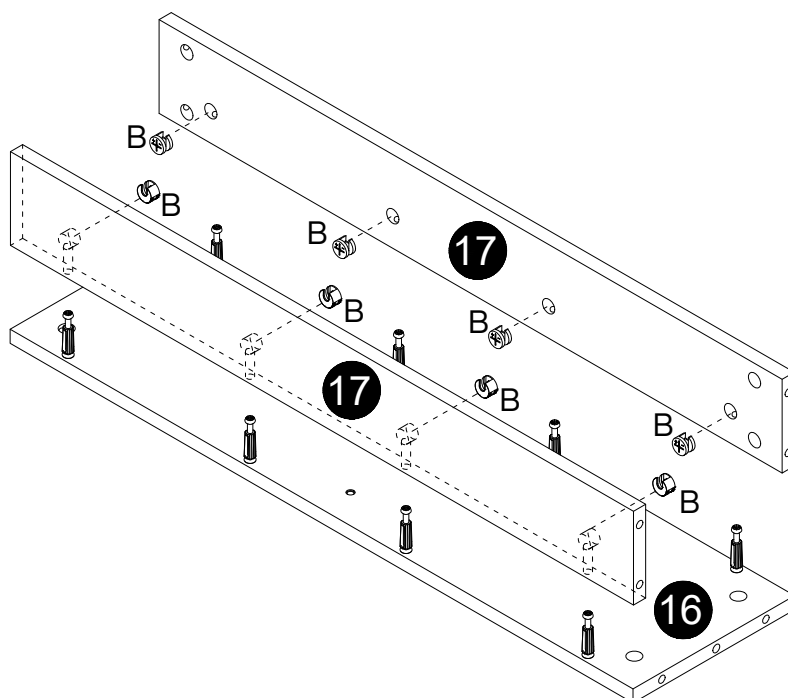
<b>B</b>

Ø15x12mm
16 pcs



x2

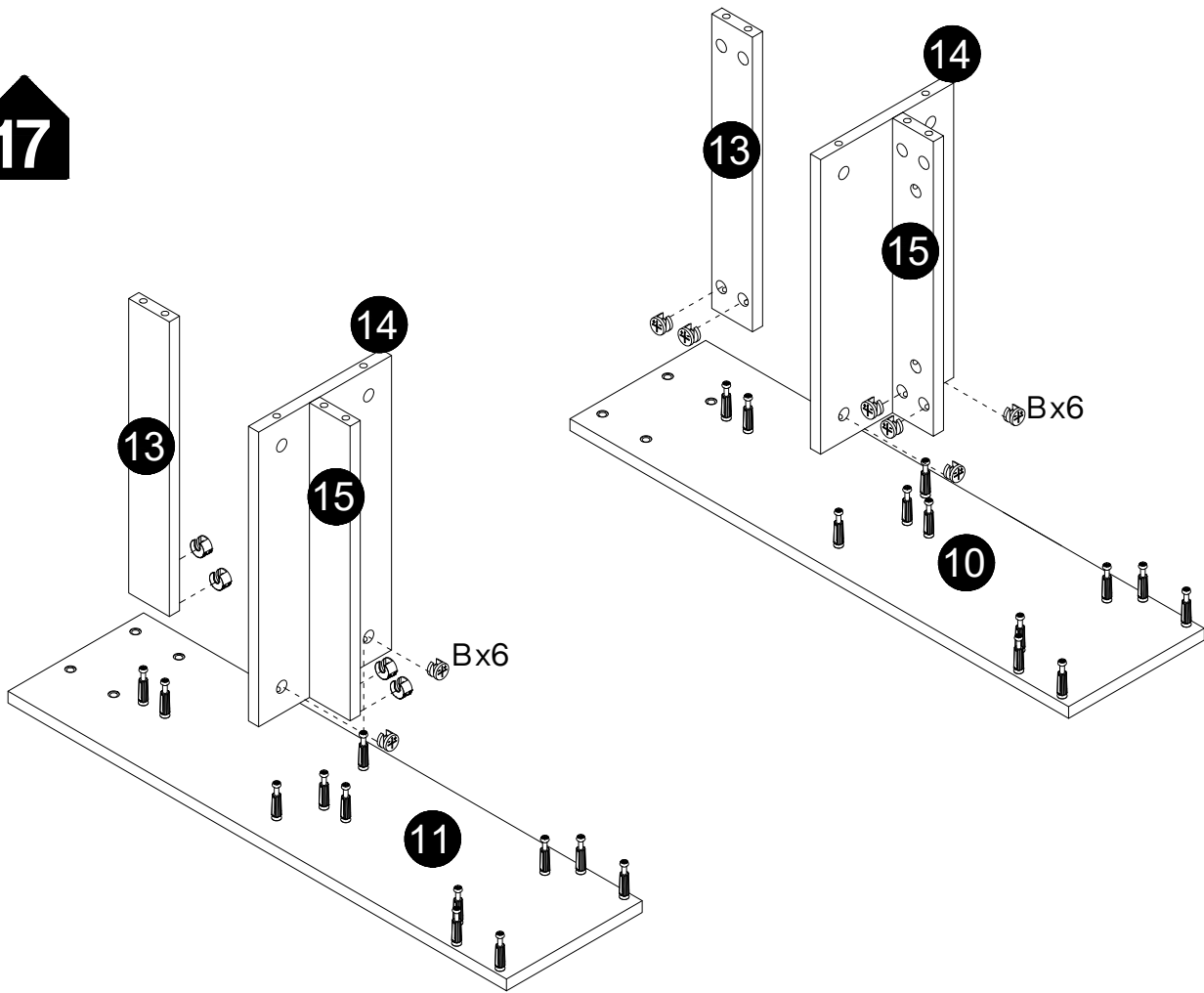

17



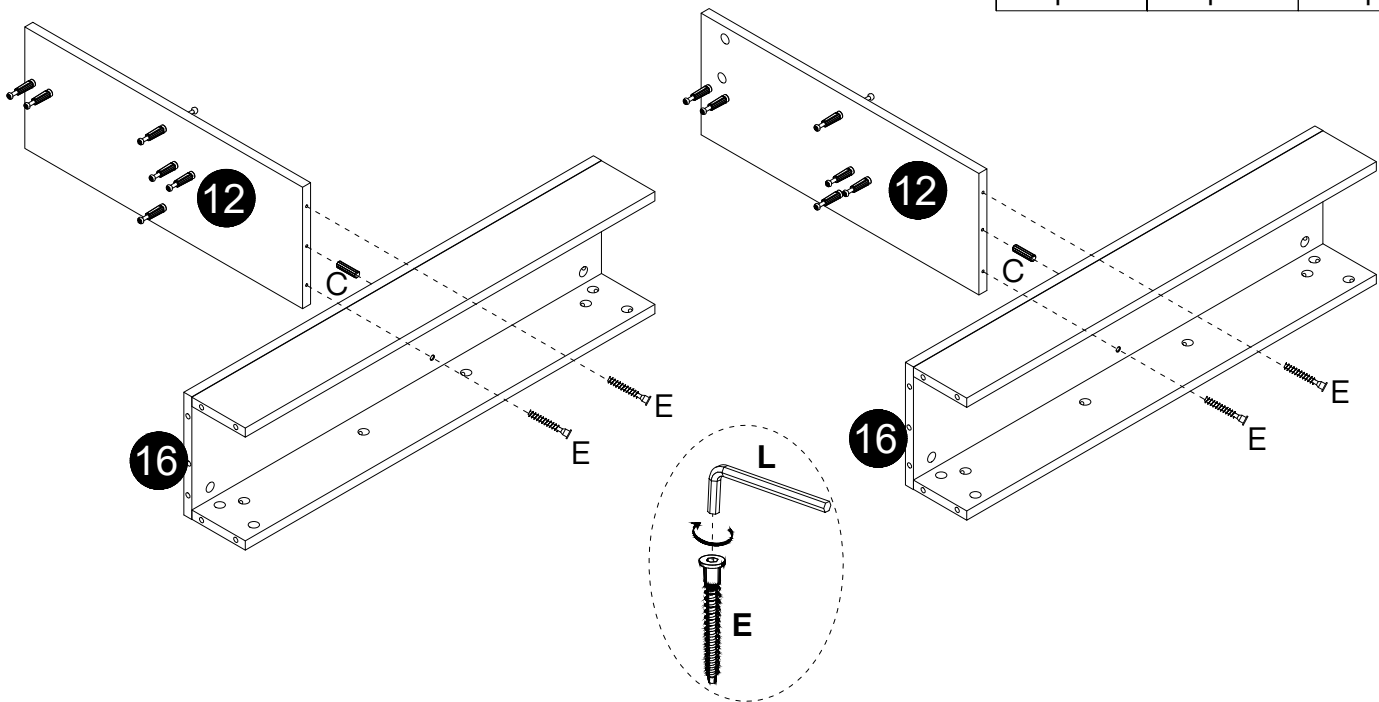

<b>B</b>

Ø15x12mm
12 pcs

18





<b>C</b>	<b>E</b>	<b>L</b>
		
Ø7.8x30mm	M5x40mm	M3
2 pcs	4 pcs	1 pc

19

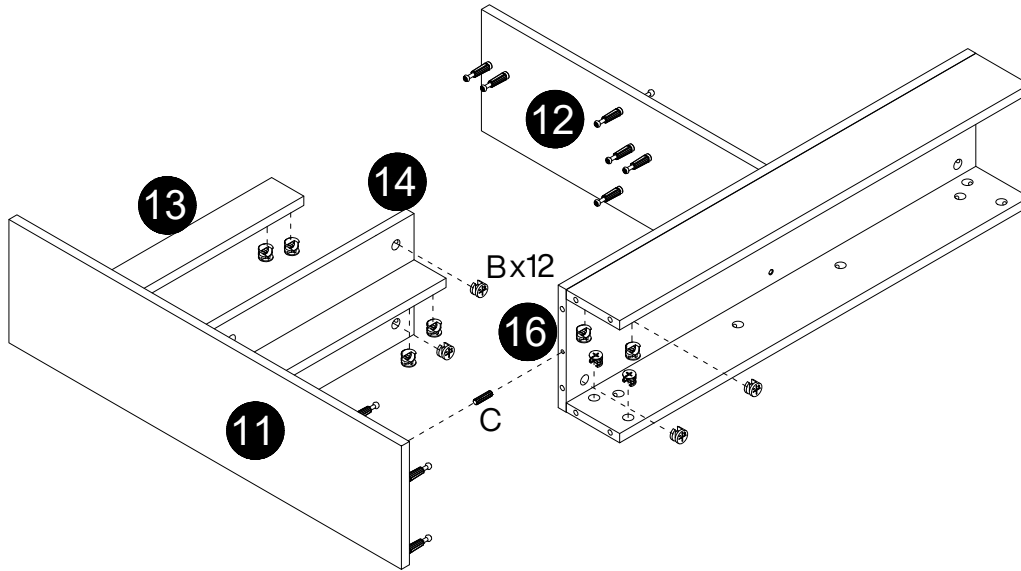
C	B
	
Ø7.8x30mm	Ø15x12mm
1 pc	12 pcs



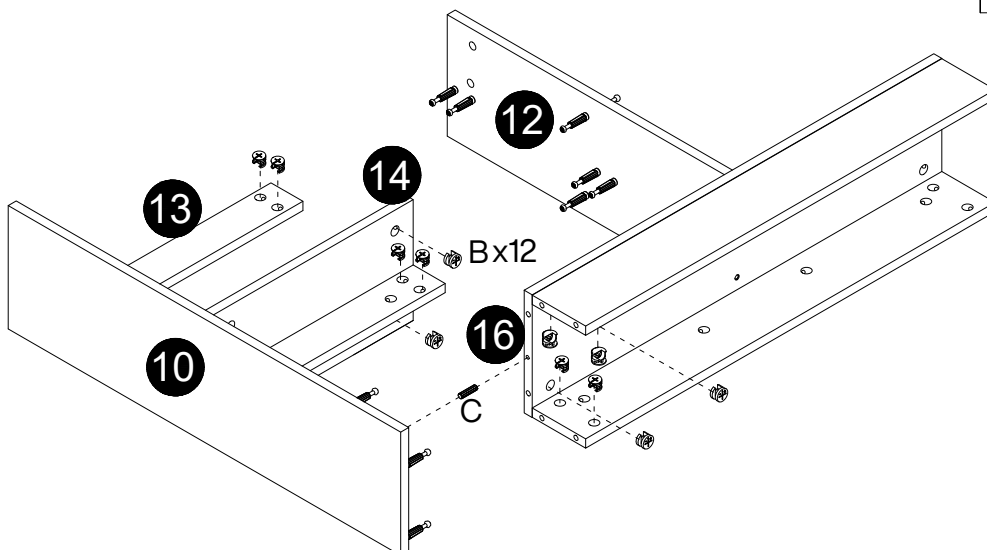

20

C	B
	
Ø7.8x30mm	Ø15x12mm
1 pc	12 pcs



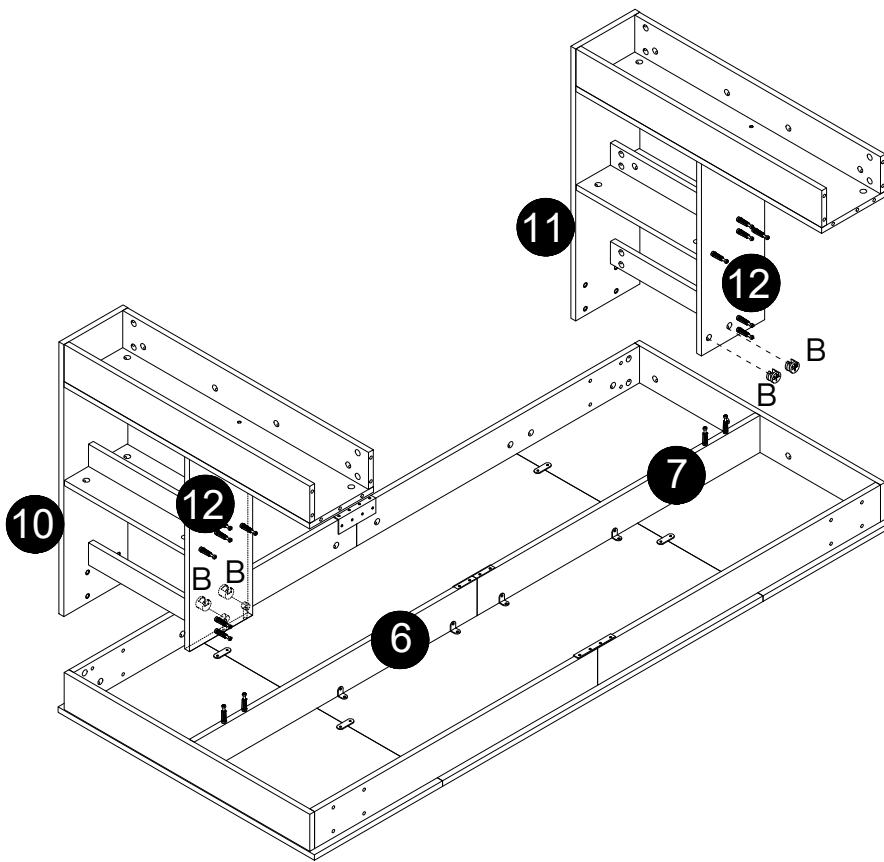

21

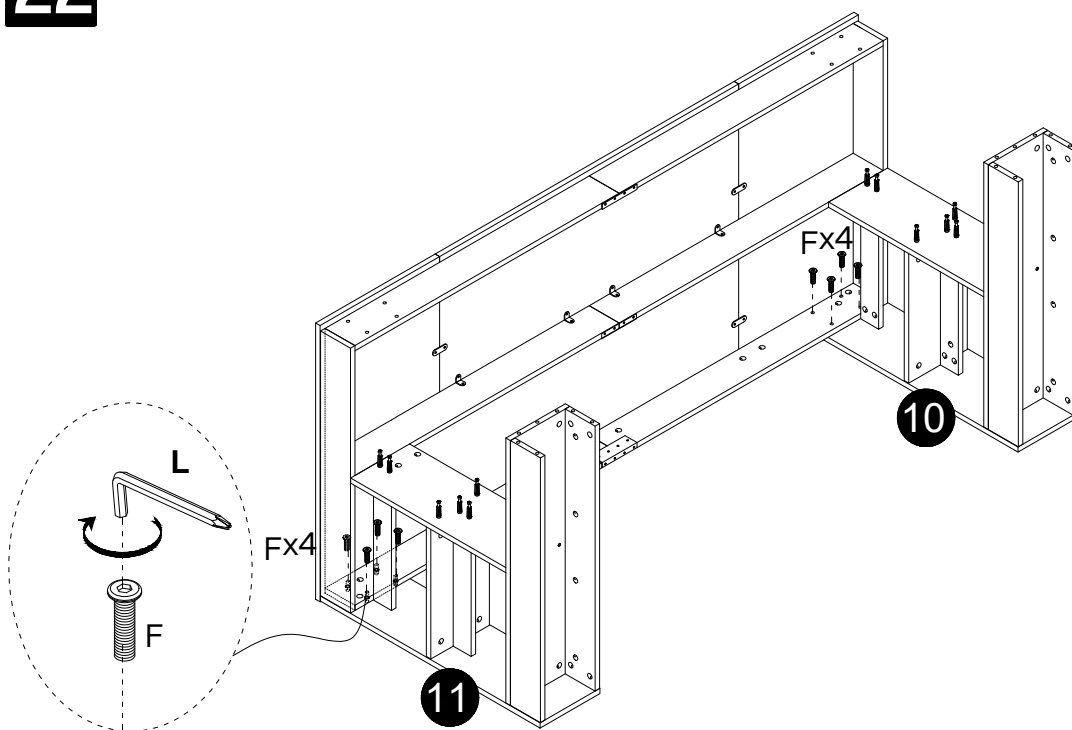

<b>B</b>

Ø15x12mm
4 pcs

22



<b>F</b>	<b>L</b>
	
M6x25mm	M4
8 pcs	1 pc

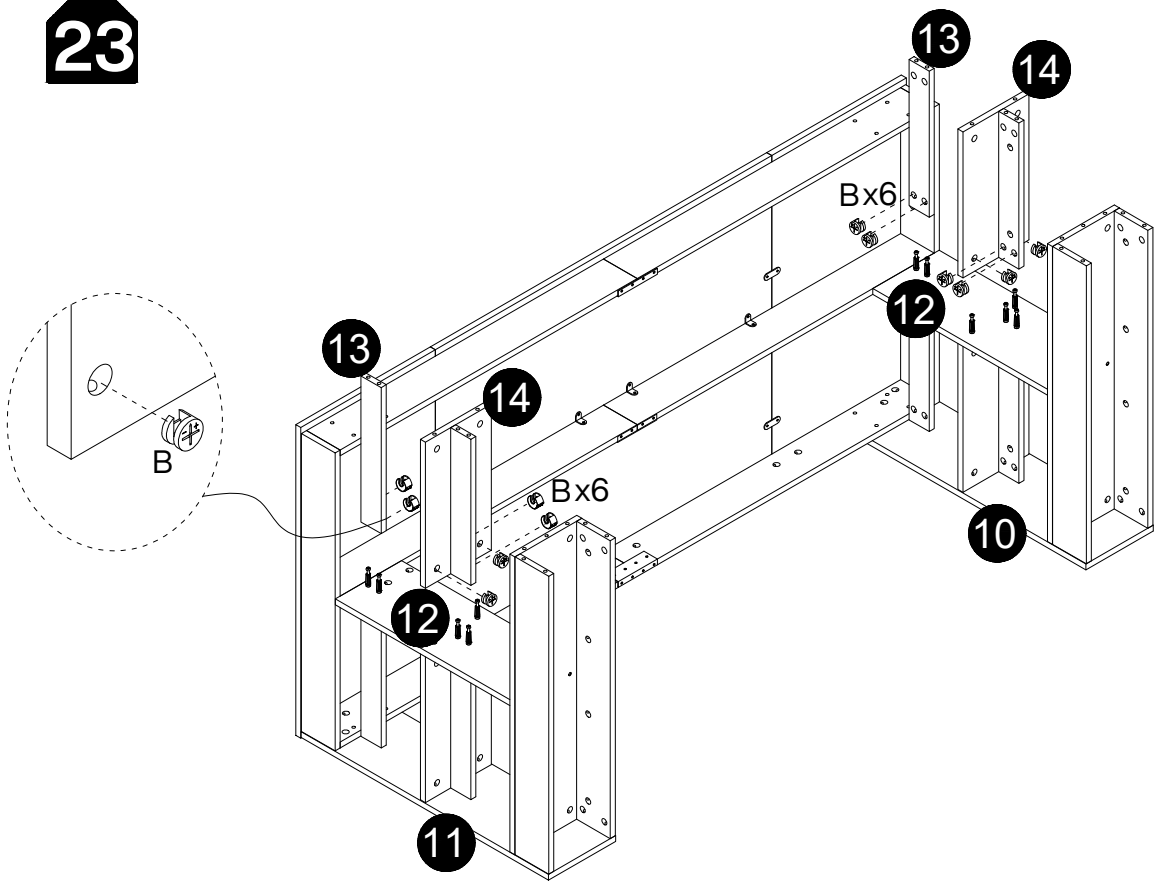

23

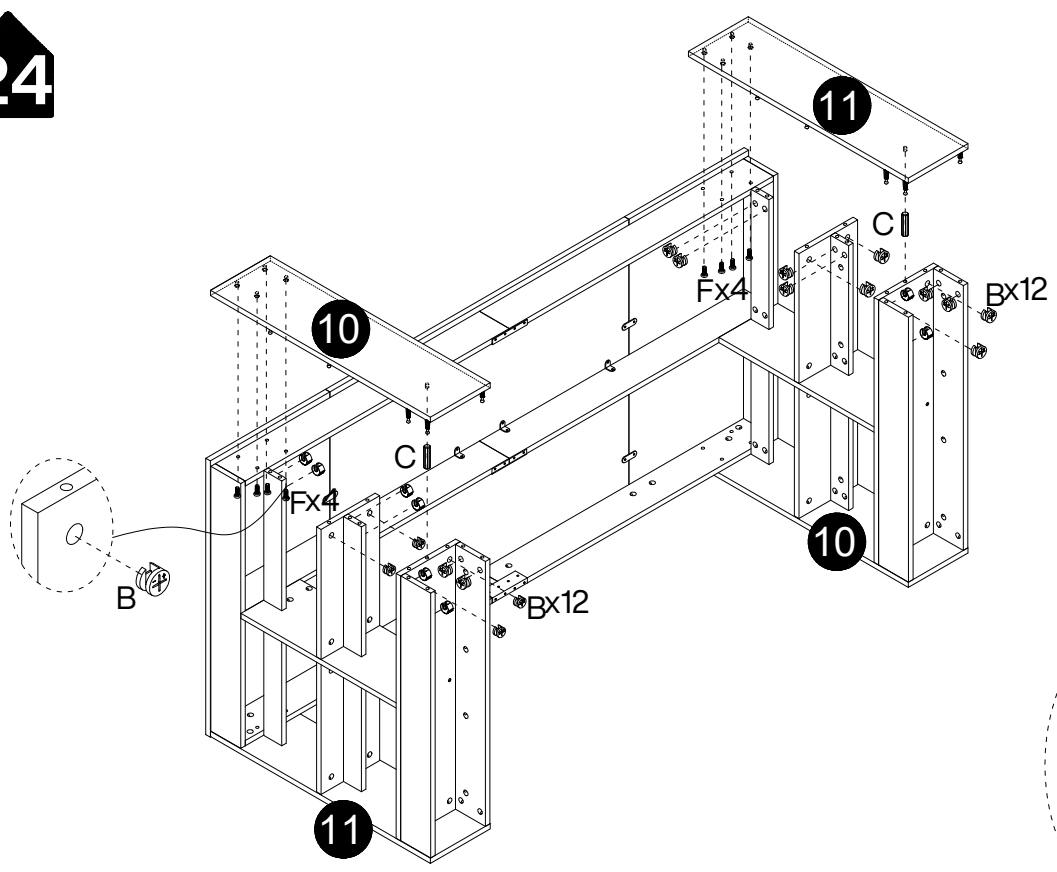

<b>B</b>

Ø15x12mm
12 pcs

24

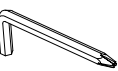

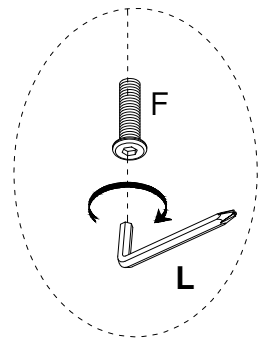
<b>B</b>	<b>F</b>
	
Ø15x12mm	M6x25mm
24 pcs	8 pcs
<b>C</b>	<b>L</b>
	
Ø7.8x30mm	M4
2 pcs	1 pc



25

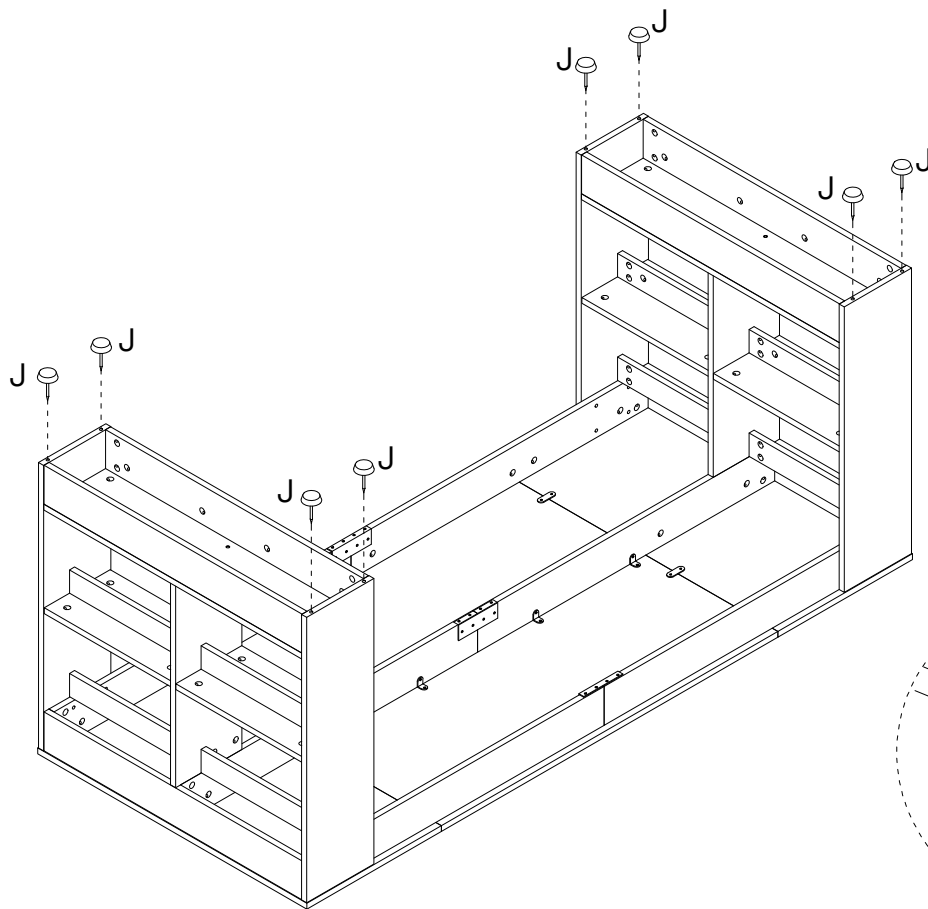

<b>J</b>

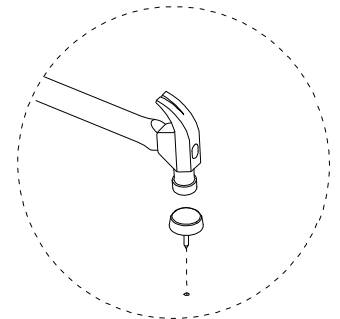
Φ14x4mm
8 pcs

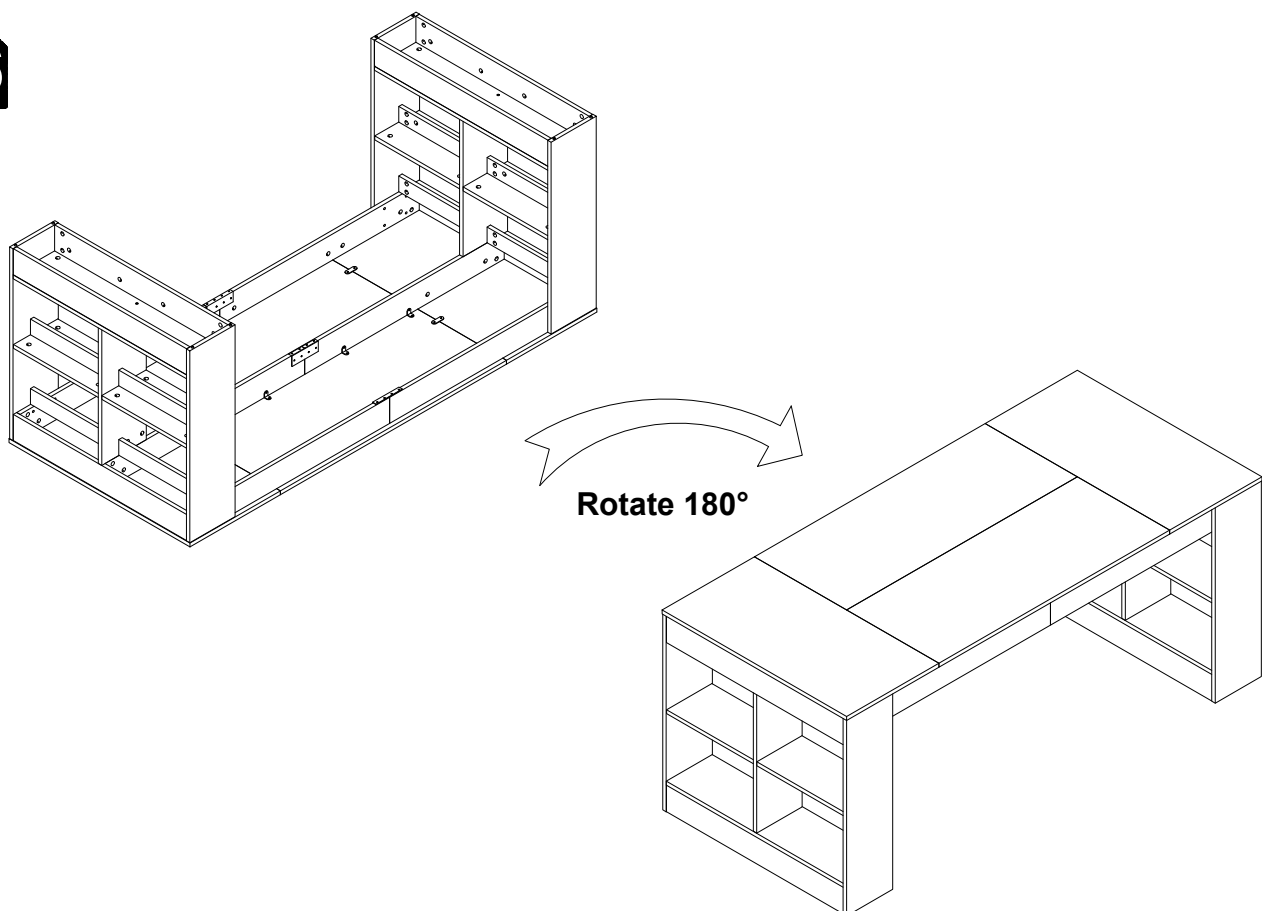

**⚠ Caution! Tap lightly**

26



**Thank you for your support!**

