

HEADBOARD SET ASSEMBLY INSTRUCTION (TOTAL 1 BOX)

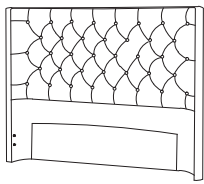

A x 1 pc

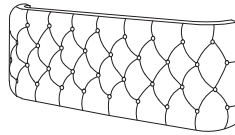

B x 1 pc



C x 2 pcs

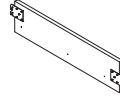

D x 2 pcs

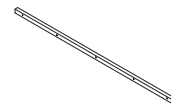

E x 2 pcs

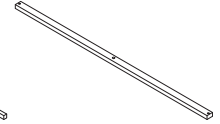

F x 4 pcs

Please read over the instructions, it will be a time-saver in the long run.

Note: Before assembly, please be sure to work on a soft flat surface to avoid any damage to the finish.

Please leave bolts loosened until all bolts are placed before tightening completely.

Part#	Picture	Description	QTY	Location	Part#	Picture	Description	QTY	Location
G		Center leg	4	Wrapped in a non-woven bag	L		Spring Washer Ø8	10	Hardware Pack
H		Legs	4	Wrapped in a non-woven bag	M		Flat Washer Ø8x25mm	10	Hardware Pack
I		Bolt Ø8x30mm	12	Already in Place	N		Screws 4x50mm	8	Hardware Pack
J		Bolt Ø8x60mm	10	Hardware Pack					
K		"L" Wrenches Ø5	1	Hardware Pack					

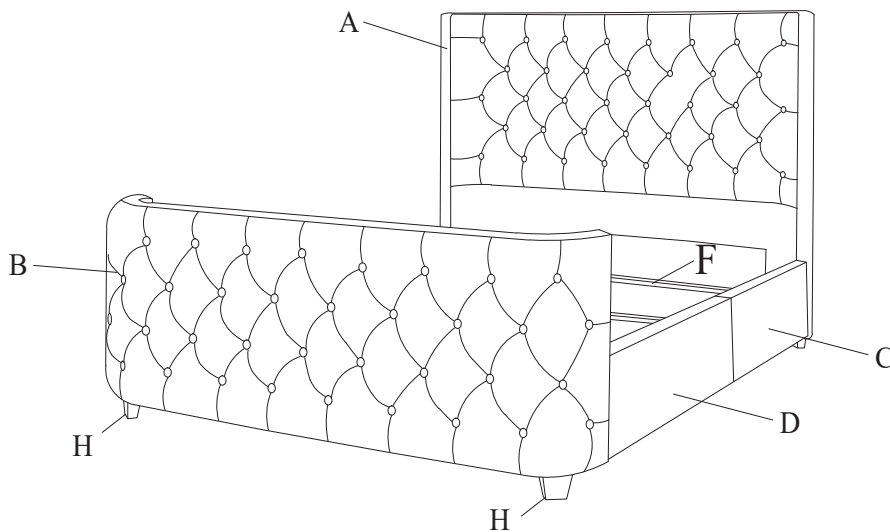

1

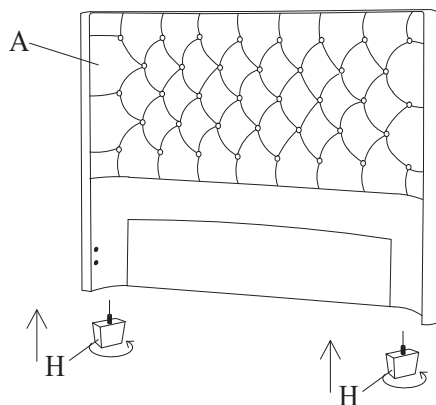

2

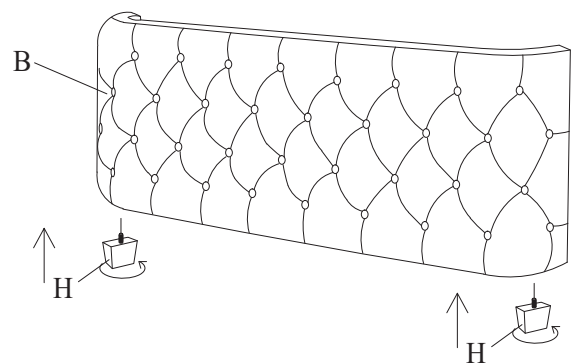

3

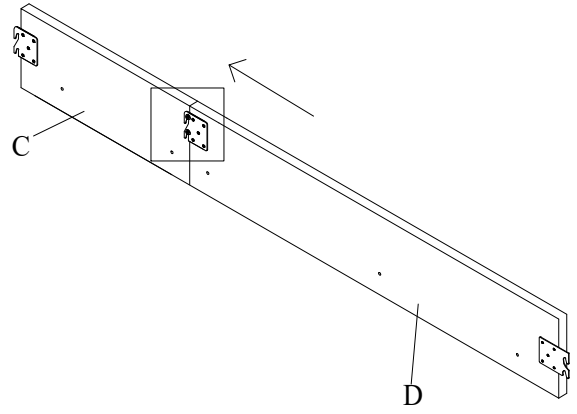
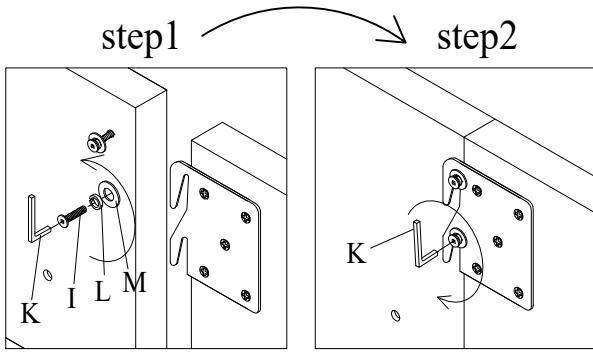

4

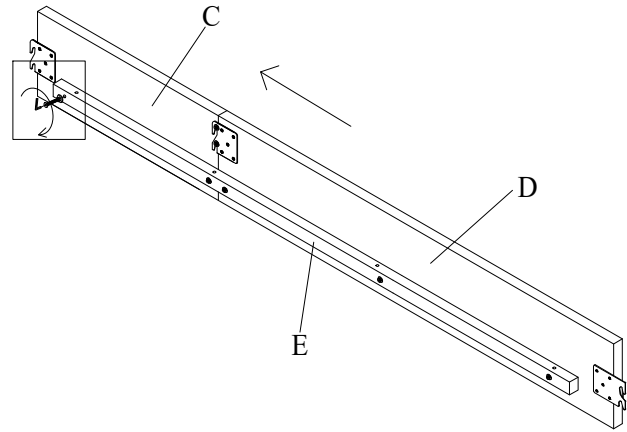
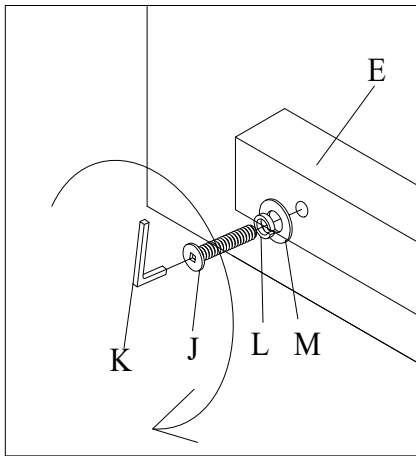

5

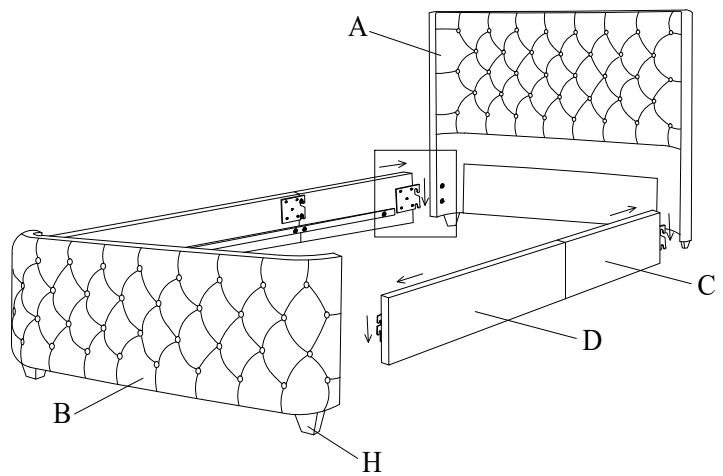
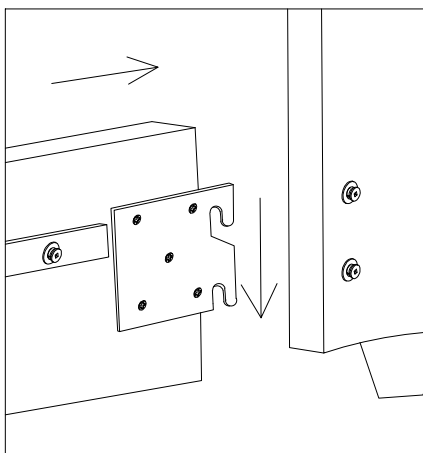

6

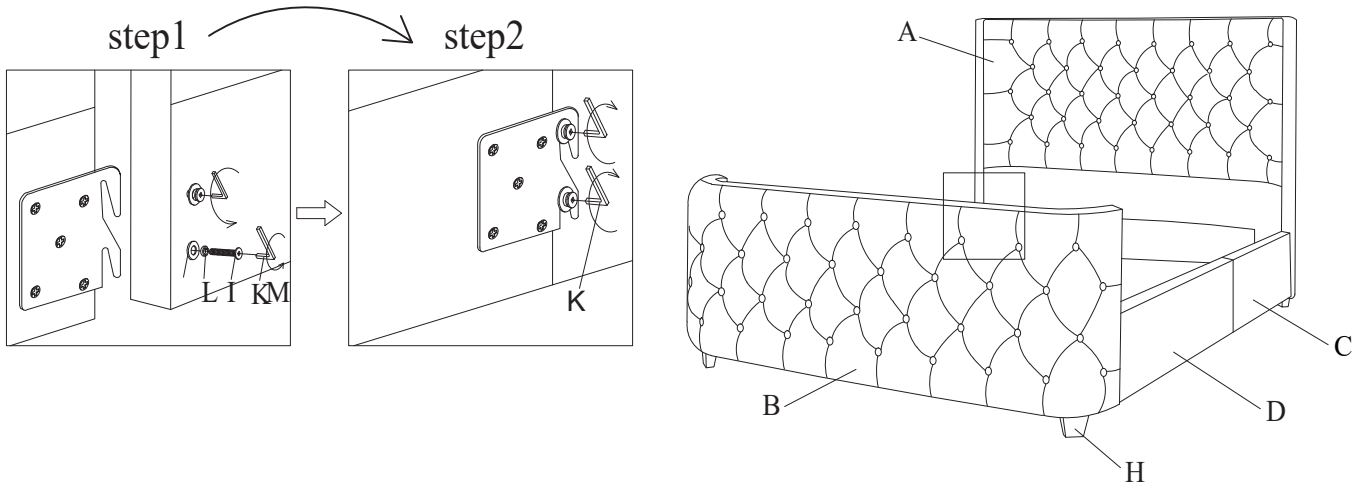

7

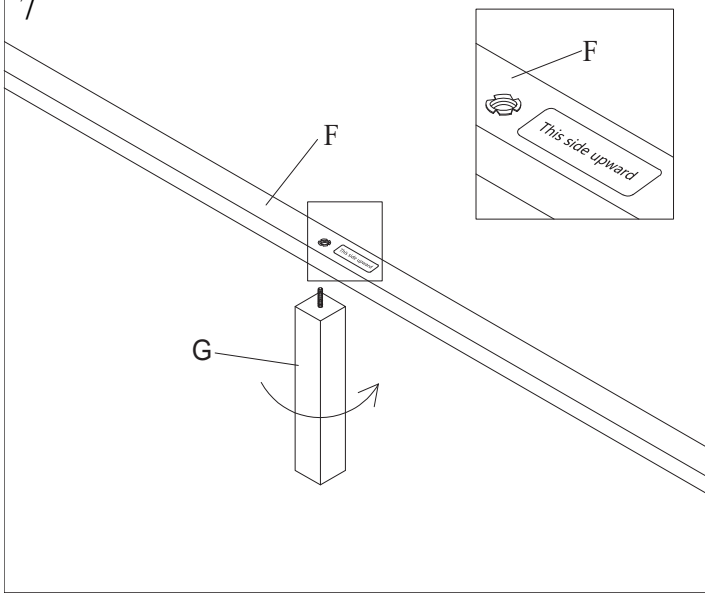

8

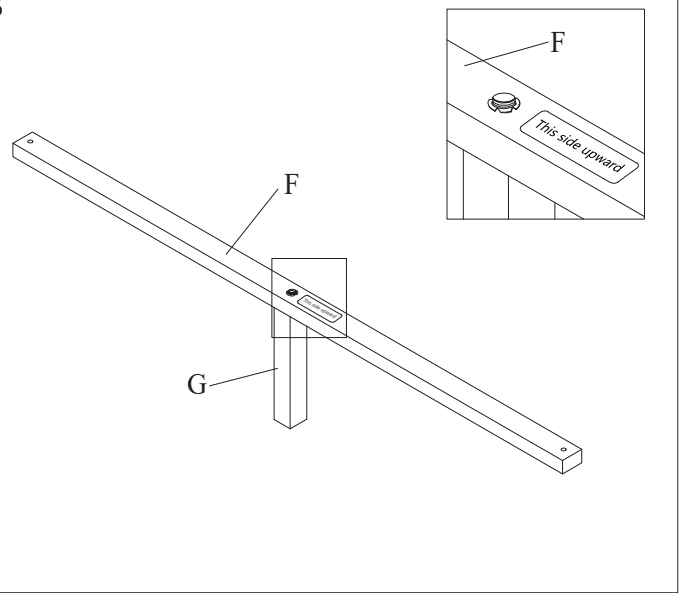

9

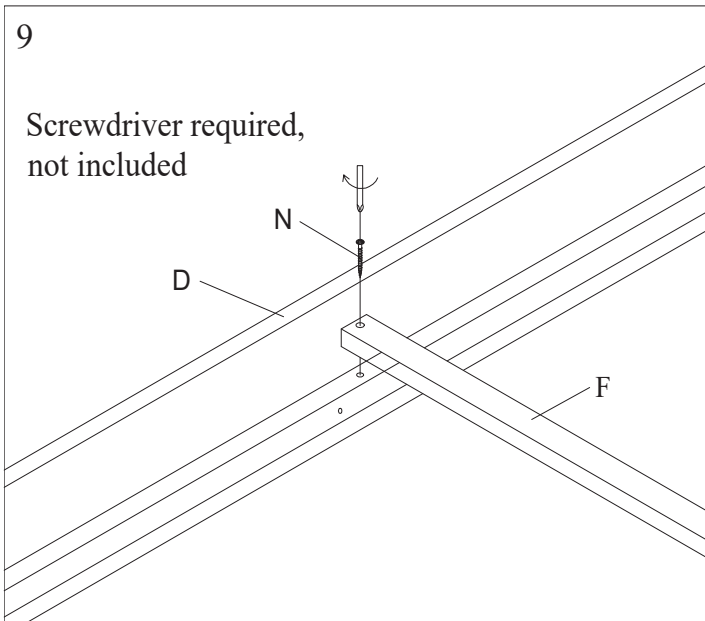

10

