

# ASSEMBLY INSTRUCTIONS

## ACCENT CHAIR

Please read instructions carefully





Remove all wrapping materials, staples and packing straps from the carton. Refer to Parts List and Hardware List and ensure they are complete before you start assembling. Place all wooden parts on a clean, flat and soft surface (e.g. carpet or rug) to prevent parts from being scratched.

- CAUTIONS:
- 1) DO NOT FULLY TIGHTEN BOLTS AND NUTS UNTIL ALL PARTS HAVE BEEN ASSEMBLED.
  - 2) DO NOT OVER-TIGHTEN BOLTS AND NUTS UNTIL ALL PARTS HAVE BEEN ASSEMBLED.
  - 3) KEEP ALL HARDWARE PARTS OUT OF REACH CHILDREN.

### PARTS LIST (FOR 2 NOS. OF CHAIRS)

NO.	COMPONENT	QTY.
P1	CHAIR SEAT FRAME	2
P2	FRONT LEGS	4
P3	BACK LEG with sticker (R)	2
P4	BACK LEG with sticker (L)	2

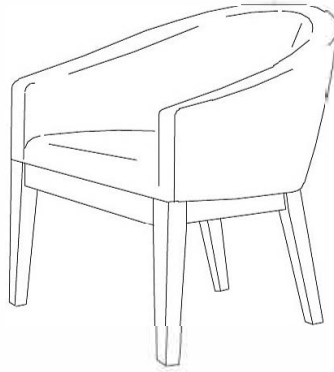

### HARDWARE LIST (FOR 2 NOS. OF CHAIRS)

NO.	DESCRIPTION	QTY.
H1	M6 x 60 JCBC SCREW 	16
H2	SPRING WASHER 	16
H3	FLAT WASHER 	16
H4	ALLEN KEY 	1
H5	NAIL LEG 	8



COMPLETE ASSEMBLY

### STEP 1

H1 x 8		M6 x 60mm
H2 x 8		
H3 x 8		

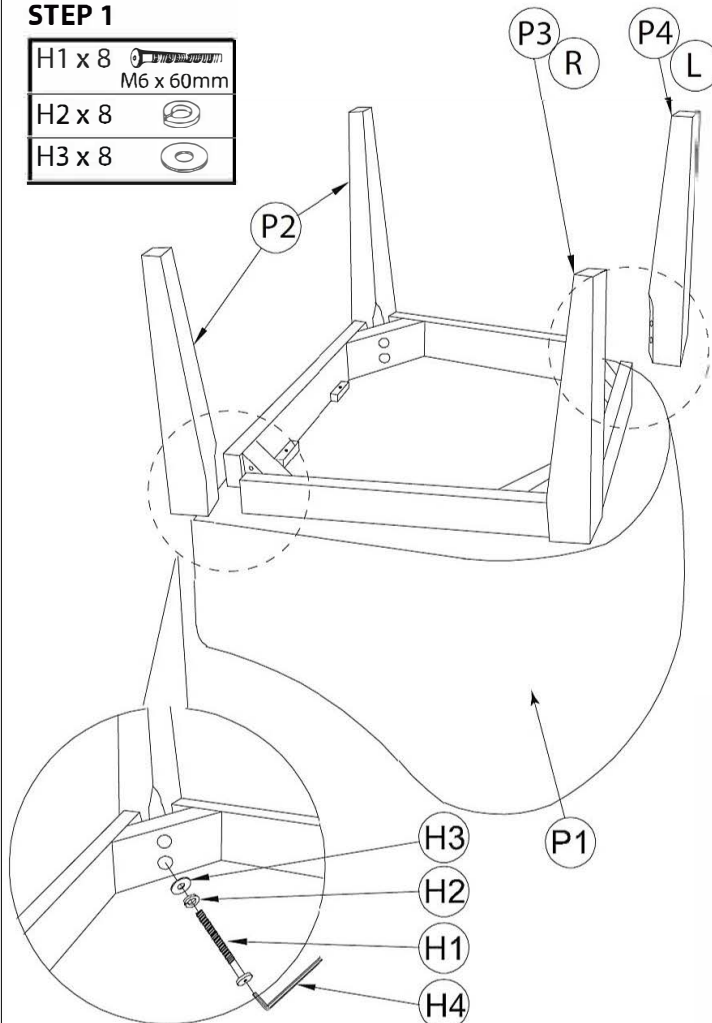

### STEP 2

H5 x 4	
--------	---

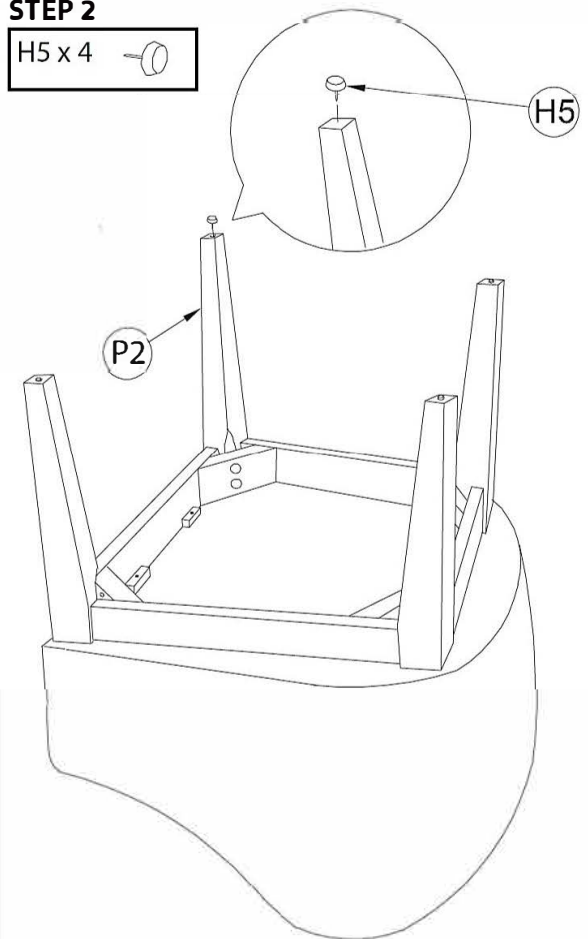

### CARE AND MAINTENANCE

- SAFETY** - To avoid any risk of suffocation to children and animals, dispose off plastic bags immediately.
- CLEANING** - Clean with damp cloth and mild detergent. Do not use bleach or abrasive products.
- FITTINGS** - Tighten bolts and nuts from time to time to ensure all parts of product are securely fitted.