

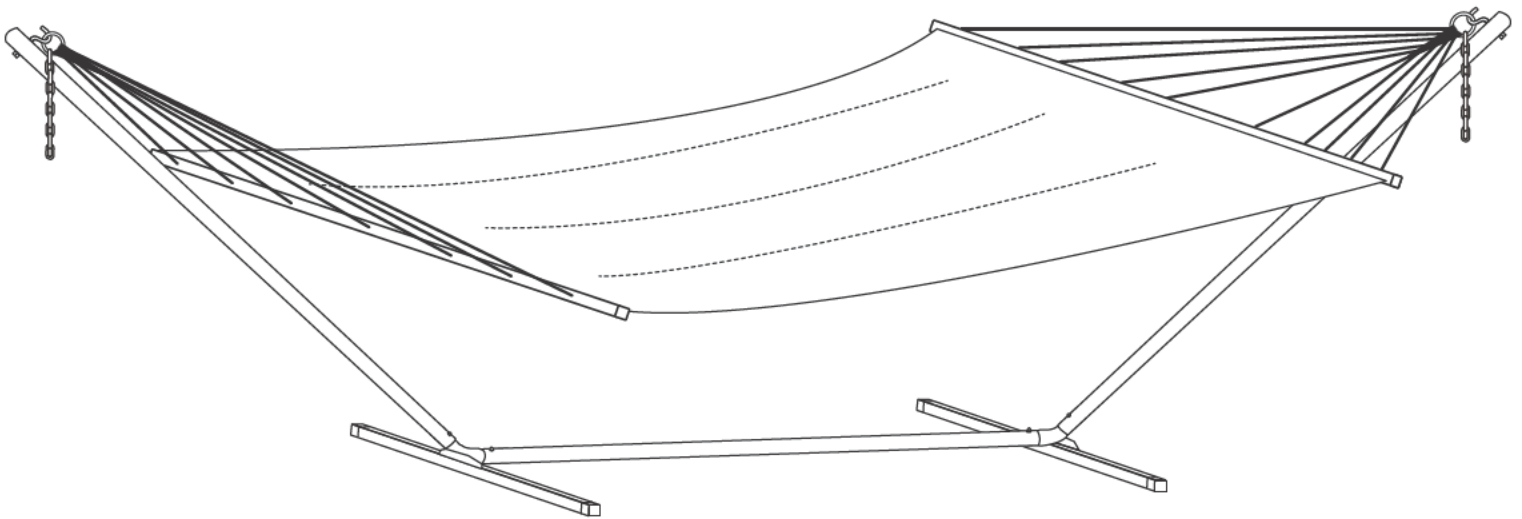

QUILTED FABRIC HAMMOCK WITH 12-FOOT HAMMOCK STAND

Read all assembly and care instructions carefully before using this product. Save these instructions for future reference.

Select a smooth, level surface to place the hammock stand.

Assemble components on a soft, clean surface to avoid scratching/damaging the finish.

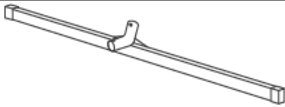

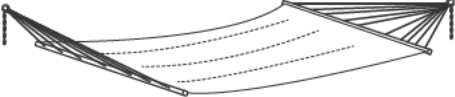
No.	PARTS		QTY.
A		Leg	2
B		Center Pole	1
C		Upright Pole with Hook	2
D		Hammock	1

 Ensure all parts are accounted for before disposing of packaging.

350
pound
capacity

HELPFUL HINT

Sunnydaze Decor advises reading this manual fully, and assembling the item soon after purchase. Check that all parts are accounted for and familiarize yourself with the assembly before beginning.

Save this manual for future reference.

ASSEMBLY

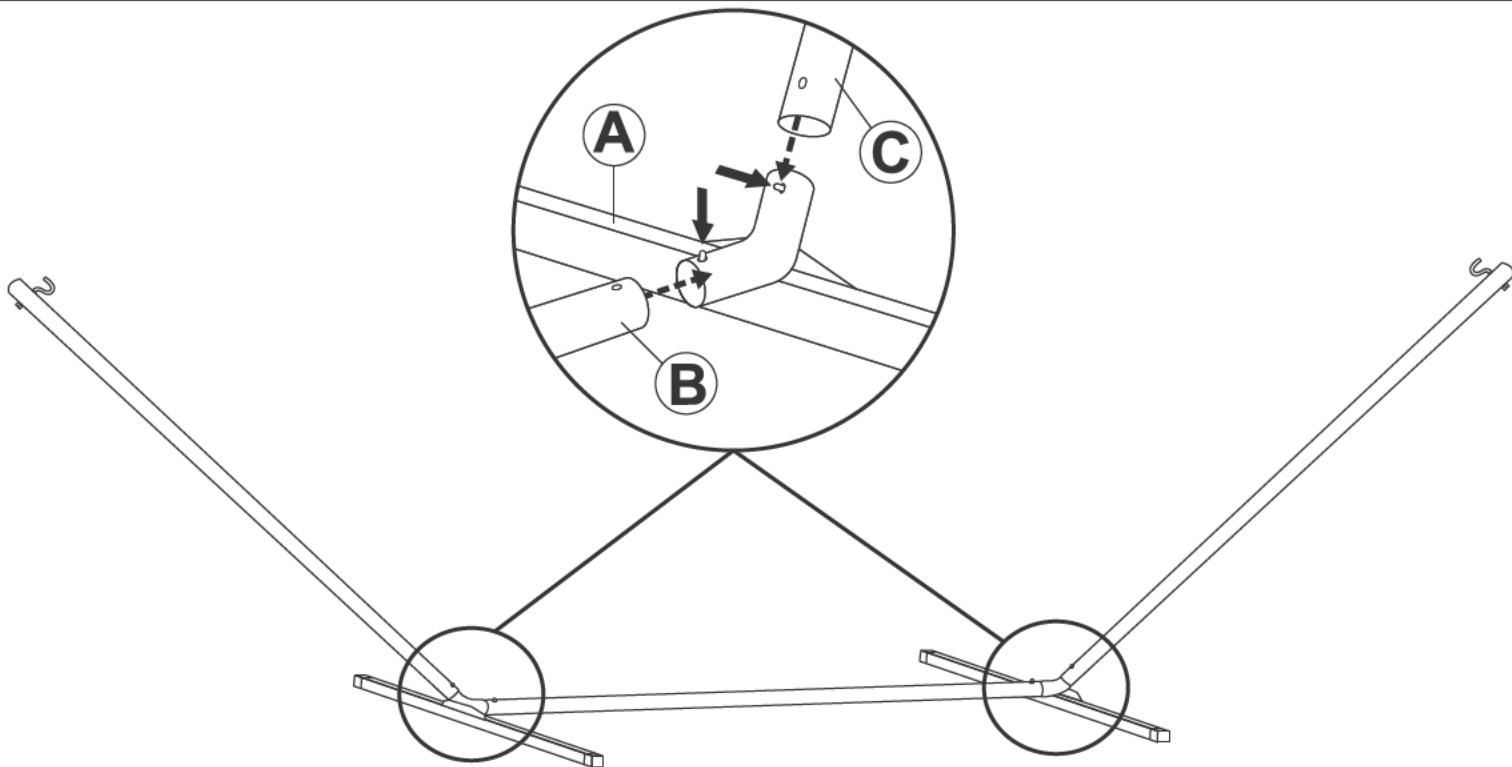

1. Place 2x Leg (A) on the ground, ensuring the elbow pipes are at a 120-degree angle.
2. Align the hole on Center Pole (B) with the spring button on Leg (A). Press the spring button down and carefully slide the center pole over the button, the spring button will snap through the hole in the center pole when it is connected. Repeat this step to connect the other leg.
3. Align the hole on Upright Pole (C) with the top spring button of the leg. Press the spring button down and carefully slide the pole over the button, the spring button will snap through the hole in the upright pole when it is connected. Repeat this step to connect the other upright pole.

HANGING THE HAMMOCK

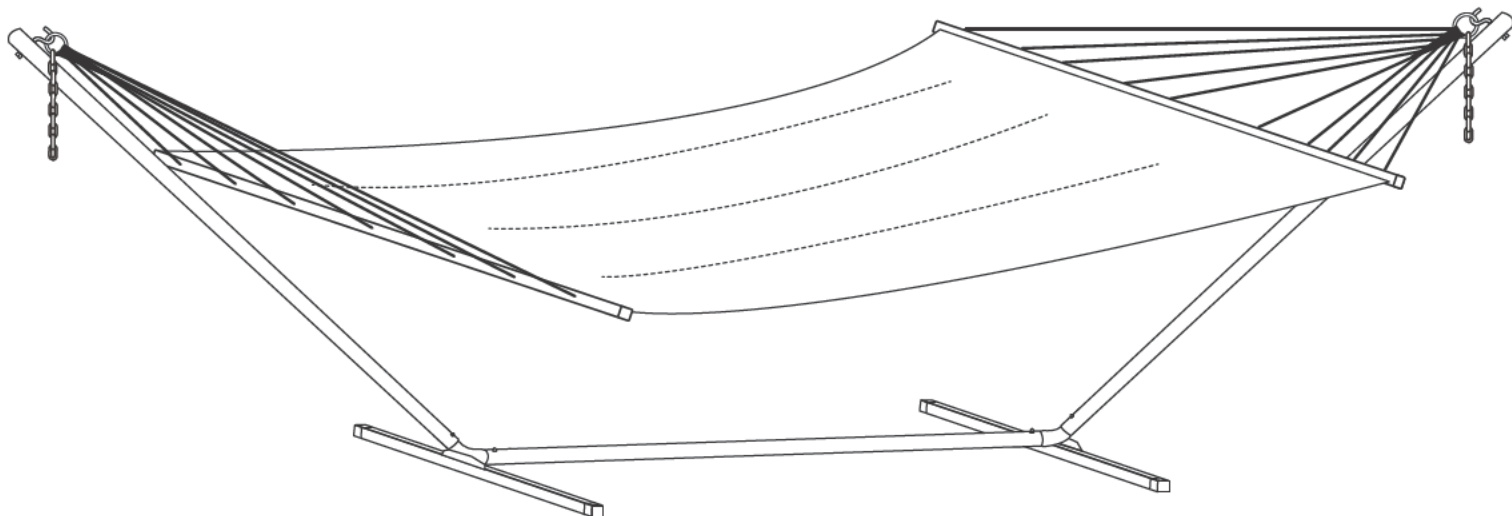

Hang Hammock (D) on the stand by the O-ring or chains that are pre-attached to the hammock. Adjust the length of the chains to tighten/loosen the fit of the hammock.

USE & CARE

- **SAFE USE:** Never exceed the weight capacity of the hammock stand, 350 lbs.
Take your time getting in and out of the hammock. Any hammock may tip if your weight is not centered.
Swinging, bouncing, jumping or any other excessive movement may result in serious injury including, but not limited to, the stand tipping over or dislodging the spring buttons causing components to disconnect.
- **CHILDREN:** Supervise children at all times. Do not allow children or pets to play or sleep in the hammock.
- **SUN EXPOSURE:** All fabrics will eventually fade and degrade from sun exposure. The less direct sunlight the hammock is exposed to, the longer the life of fabric and ropes will be.
- **STORAGE:** Store indoors when not in use. Cool, dry locations are recommended to prevent damage that may result from exposure to moisture.
- **INSPECTION:** Examine the stand before each use to ensure it is assembled correctly and all connection points are secure.
Frequently inspect the ropes, fabric and spreader bar for wear or weakness.
- **SCRATCHES:** The powder coating on the stand is tough and durable but even under normal use, some scratching is inevitable. To prevent excessive rust, wipe scratched areas to remove moisture.

CLEANING



SPOT CLEAN/HAND-WASH ONLY



DO NOT USE BLEACH OR FABRIC SOFTENERS



LAY HAMMOCK FLAT TO DRY



DO NOT IRON HAMMOCK

HAMMOCK

Spot clean with a damp cloth.

For more stubborn stains, hand-wash in a bathtub or kiddie pool using mild soap and a soft-bristled scrub brush. Soaking may be required for heavily soiled fabrics. Keep the wooden spreader bars, galvanized O-rings and chains out of the water as much as possible.

Thoroughly rinse all soap residue. Air-dry on a flat surface to prevent the ropes from stretching. The ropes may shrink slightly while drying, but will stretch back out with use.

HAMMOCK STAND

Use a soft cloth and warm water to wipe down the stand. Wipe away moisture with a soft, clean cloth.

SAFETY STATEMENTS & WARNINGS

- Before each use, inspect the hammock and stand for wear or weakness. Do not use if connection points on the stand are not fully engaged/secure, or if ropes are frayed or fabric is torn on the hammock.
- Excessive swinging and other rough play may result in serious injuries.
- Only use this item on a flat, level surface.
- Small children should not use the hammock unsupervised.
- Pets should not be allowed into hammocks as it may result in injuries or damage the product.
- Do not exceed the recommended weight capacity of the stand, 350 lbs.
- Never untie the ropes of the hammock.

Any modification to the product or failure to follow recommended care will void the product warranty.

WARNING:

Manufacturer and seller expressly disclaim any and all liability from personal injury, property damage or loss, whether direct or indirect, or incidental, resulting from the incorrect attachment, improper use, inadequate maintenance, or neglect of this product.