





















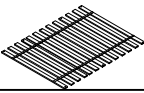

TOOLS REQUIRED				HARDWARE LIST			
PARTS LIST:							
NO	Description	Sketch	Quantity	NO	Sketch	Description	Quantity
1		Left Arm	1PC	A		Allen wrench M5	1PC
2		Right Arm	1PC	B		Bolt Ø5/16" x 1"	12PCS
3		Leg	4PCS	C		Bolt Ø5/16" x 2-1/2"	4PCS
4		Back Rail	1PC	D		Lock Washer $\frac{5}{16}$ "	16PCS
5		Front Rail	1PC	E		Flat Washer $\frac{5}{16}$ "x 21mm	16PCS
6		Back Rest	1PC	F		Allen wrench M4	1PC
7		Centre Rail	1PC	H		Bolt Ø1/4" x 5/8"	16PCS
8		Top Slats (13pcs)	1Set	I		Bolt Ø1/4" x 1-1/8"	12PCS
9		Trundle Back Panel	1PC	J		Lock Washer 1/4"	28PCS
10		Trundle Front Panel	1PC	K		Flat Washer 1/4"x 16mm	28PCS
11		Side Iron Tube	2PCS				
12		Down Slats (13pcs)	1Set				
13		Wheel	4PCS				

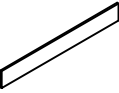

STEP 1

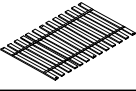

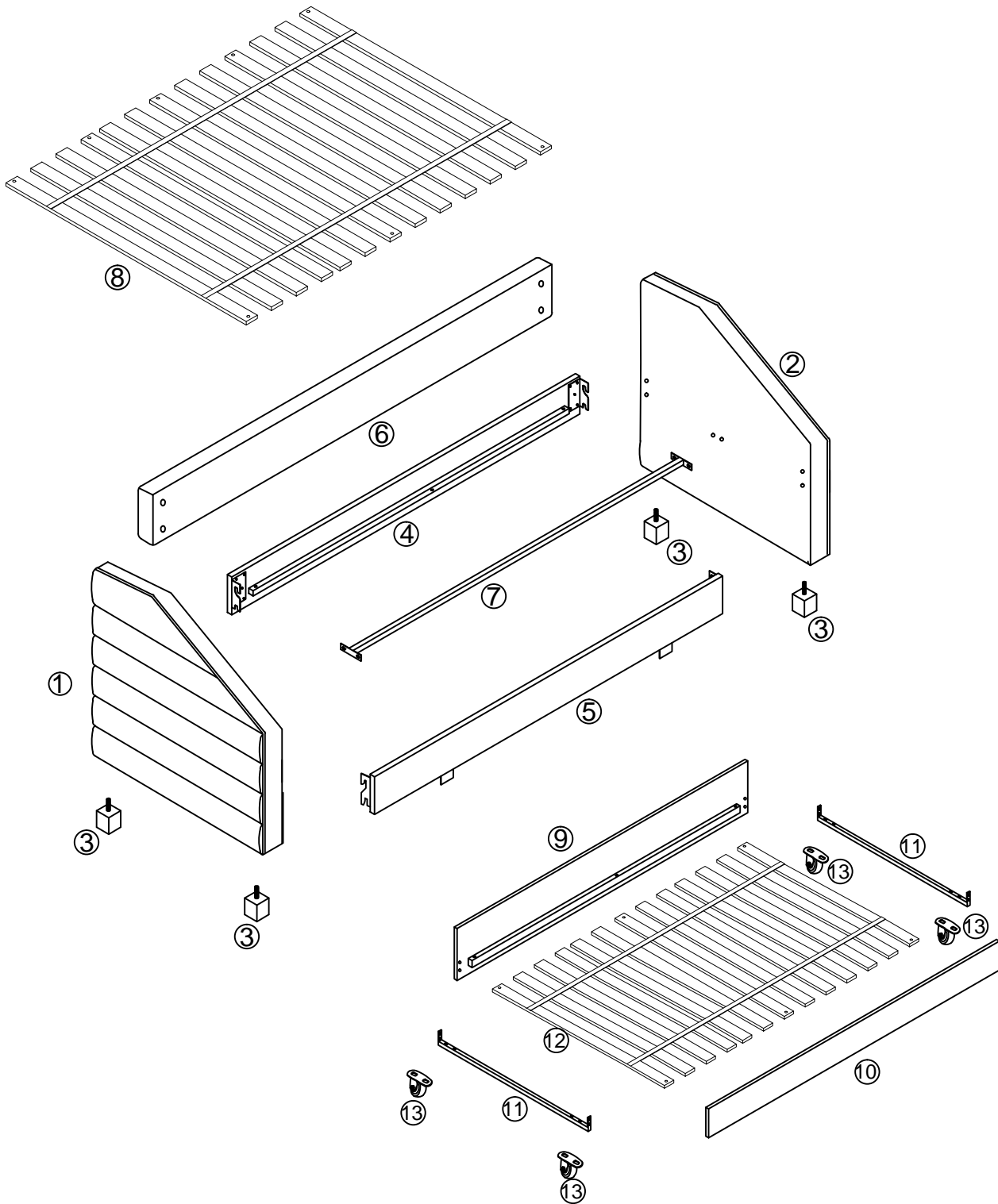
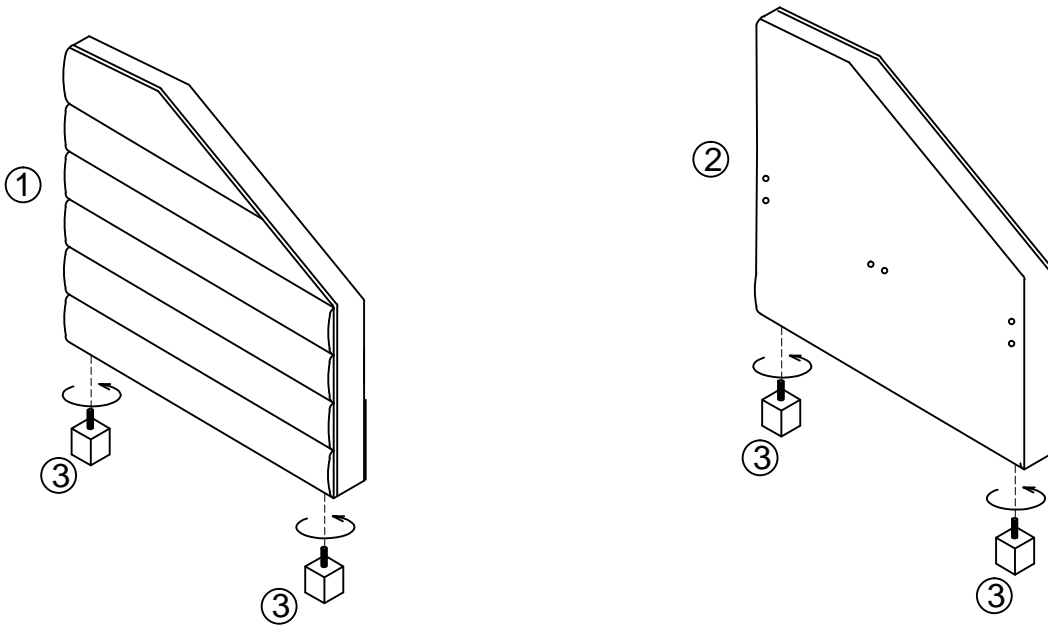
STEP 2

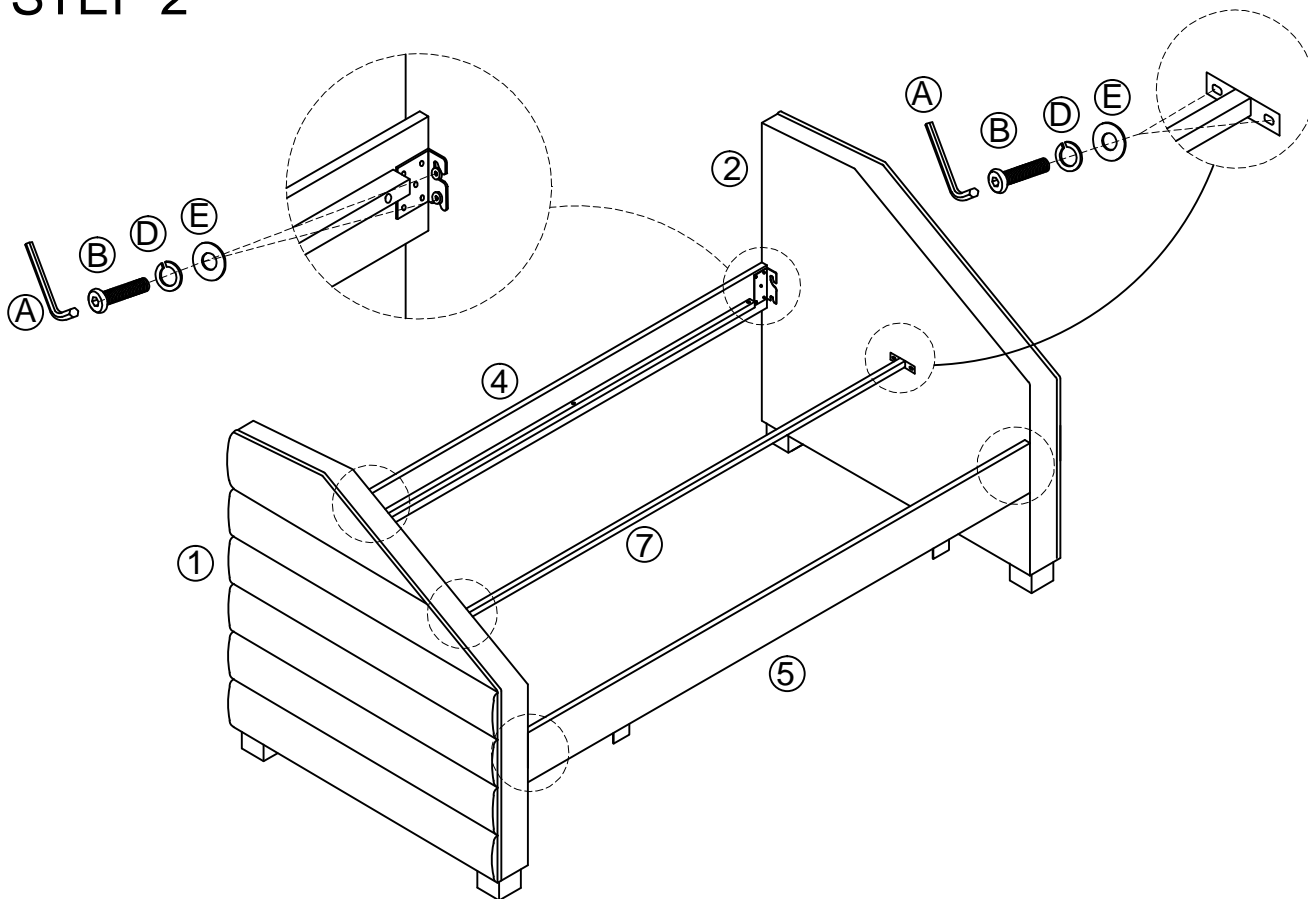

STEP 3

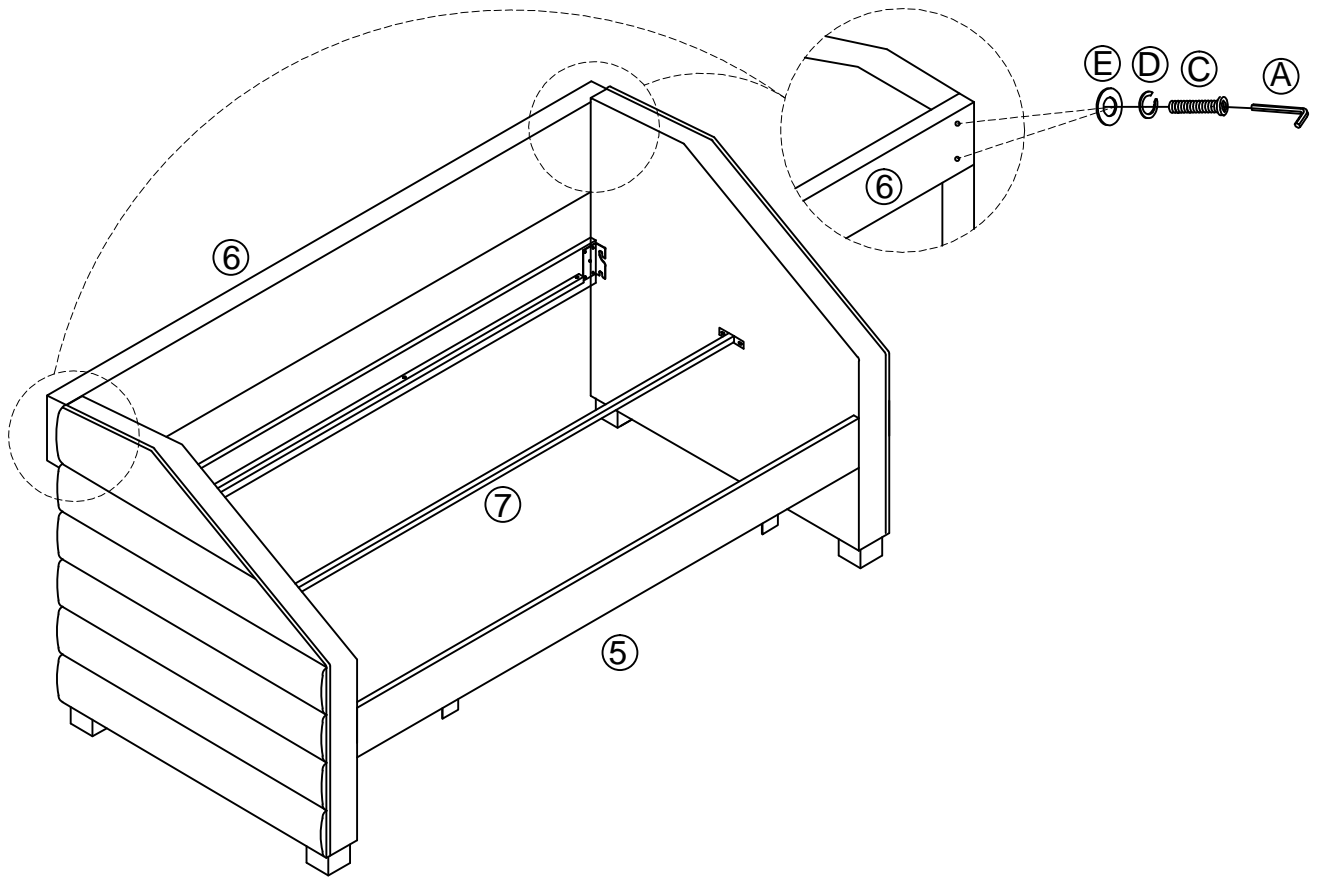

STEP 4

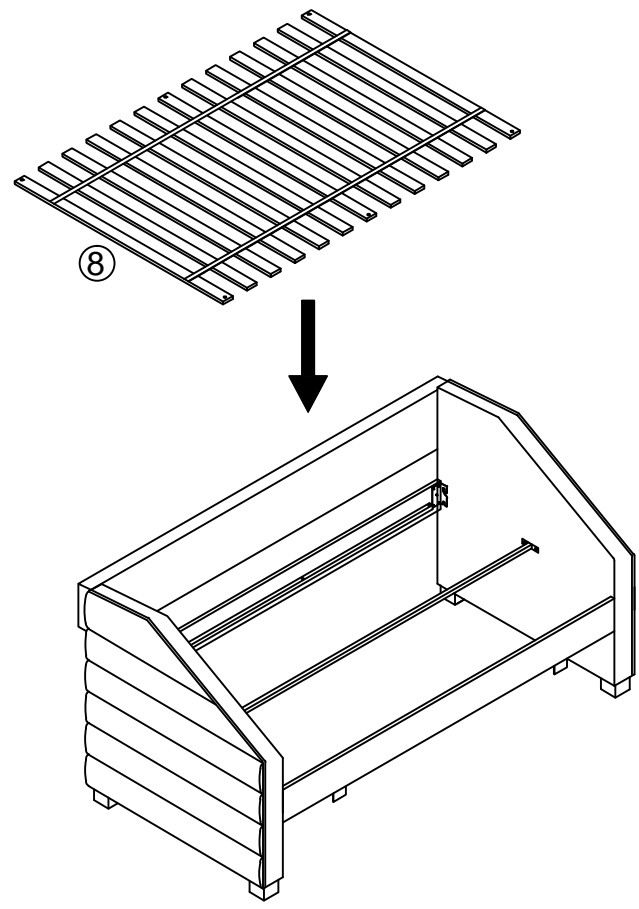

STEP 5

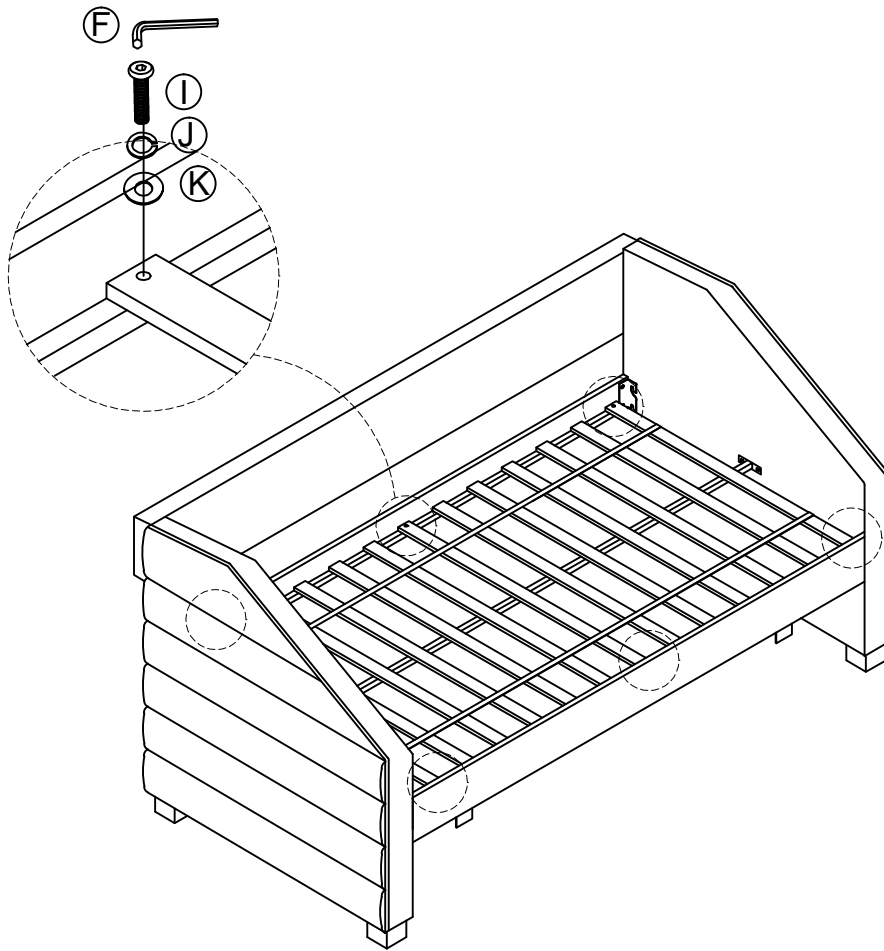

STEP 6

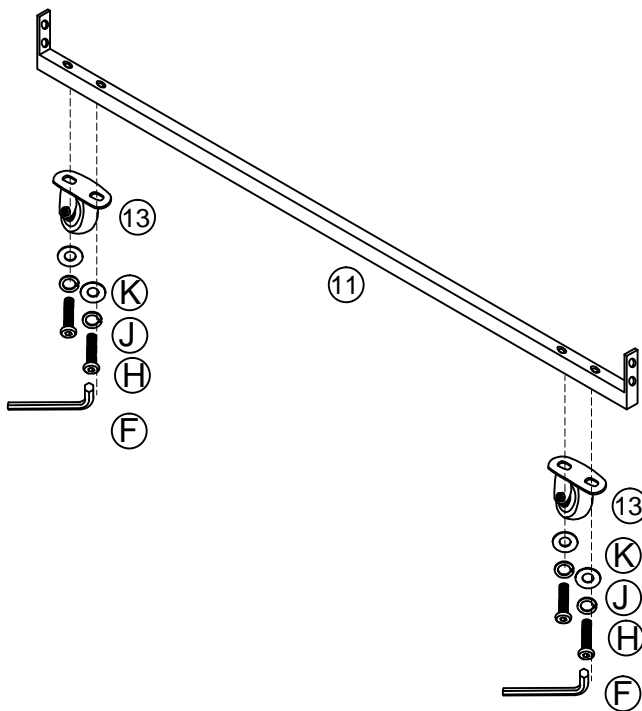

X 2

STEP 7

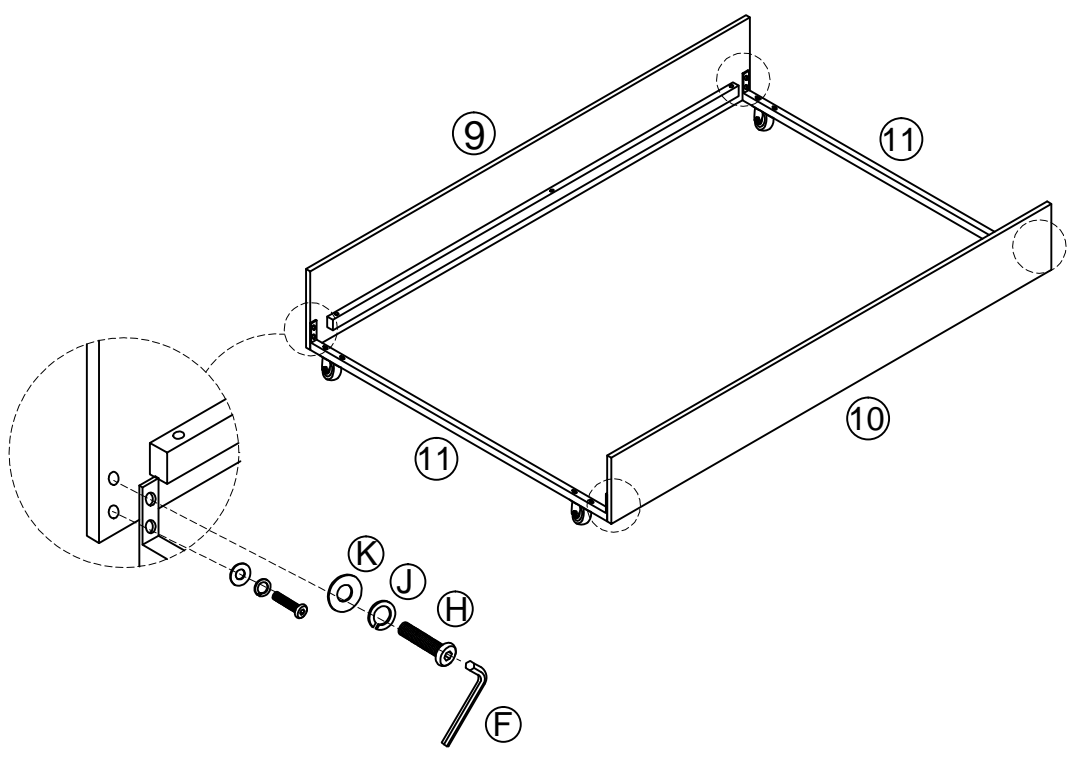

STEP 8

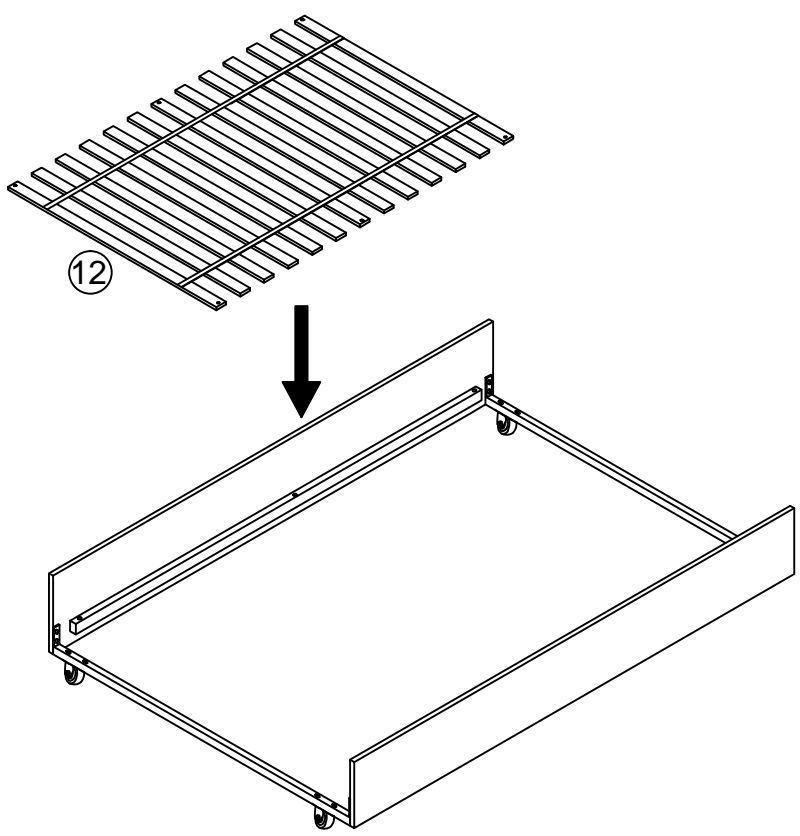

STEP 9

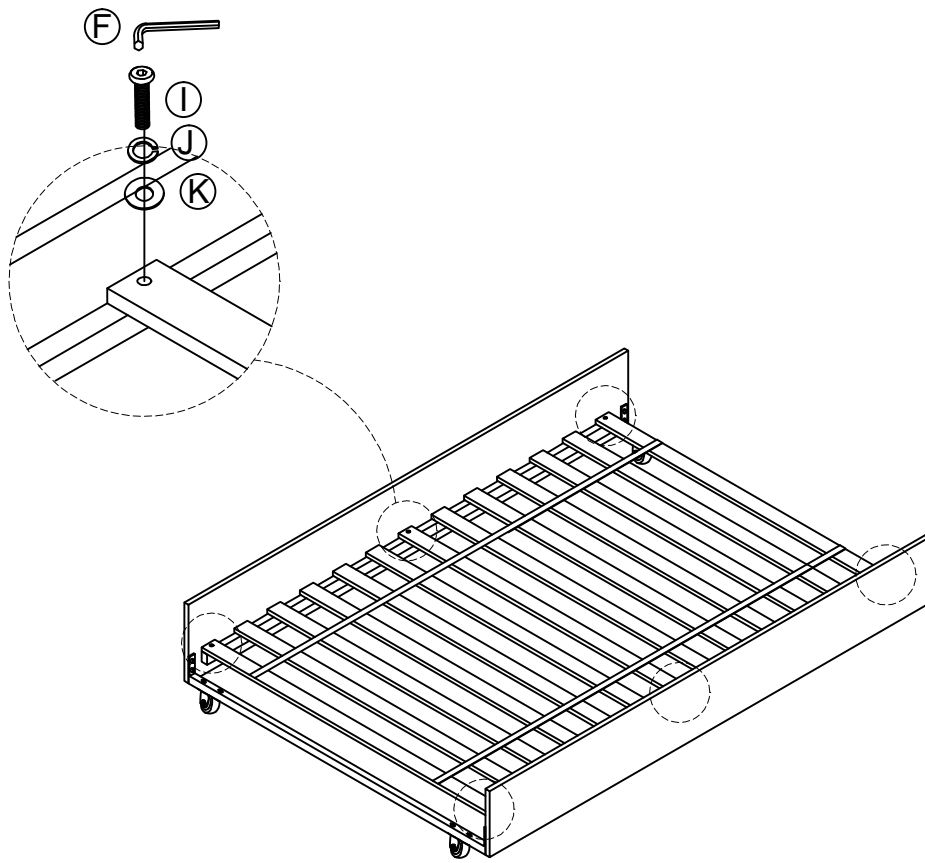

STEP 10

