

OWNER'S MANUAL

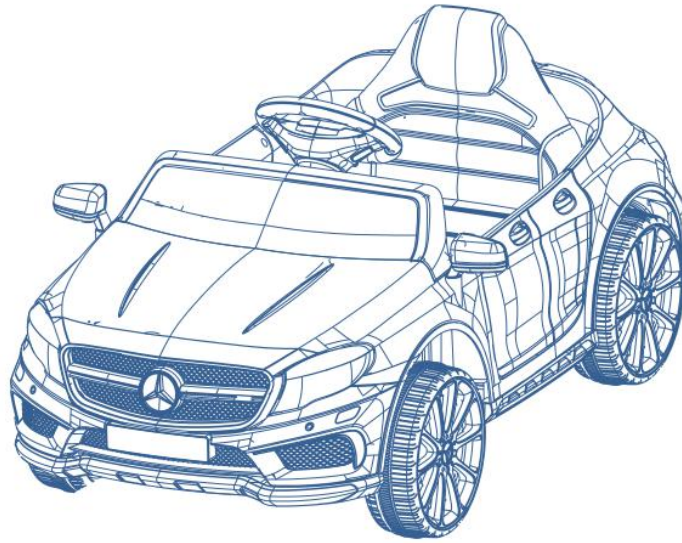

- Four suspension
- USB, MP3, TF card Jack
- Leather seat cover (optional)
- Maximum user weight:30 KGS
- Swing function (optional)
- Two opening doors
- Rubber wheels (optional)



WARNING

- Must be assembled by an adult!
- Read and understand this entire manual before using!
- Before first time use, charge the battery for at least 4-6 hours.
- Please keep this manual well for reference in the future.
- The toy should be used with caution since skill is required to avoid falls or collisions causing injury to the user or third parties.

Warning: Not to be used in traffic !

Table of Contents

- 1.Specification
- 2.Structure chart
- 3.Assembly steps
- 4.How to operate your “Ride on”
- 5.How to use Controller
- 6.Charging the battery
- 7.Trouble shooting guide
- 8.Maintaining your “ride on”
- 9.Wiring diagram
- 10.Disclaimer

Specification





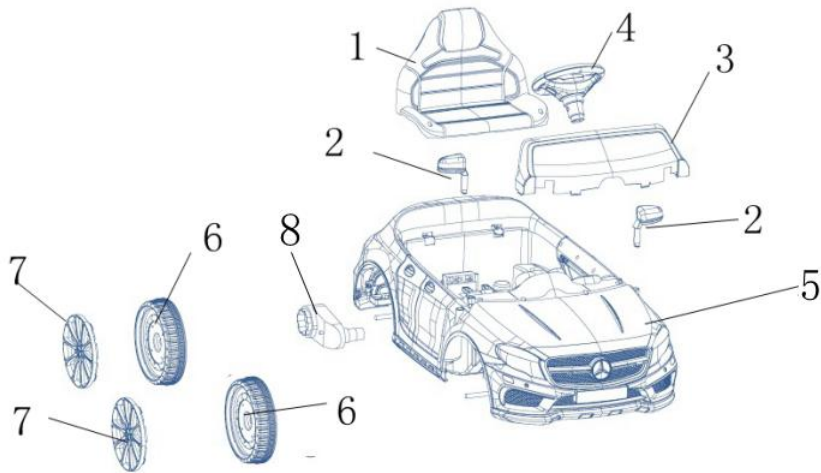

Thanks for purchasing our products, we hope your children enjoy this product for years to come. Keep these points in mind as you read this guide:

Suitable age: 3-8 years	Power way: Rechargeable
Load capacity: 30KGS	Battery:6V 4.5Ah, 12V 4.5Ah
Speed:3KM/H	Packing Size:100*49*30 CM
Charger: 6V 500MA 12V 700MA	Charging Time:8-12 hours

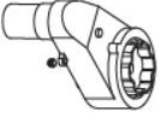
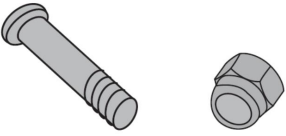

Structure chart

Item	Name	Picture	Qty.	Note
1	Seat		1	
2	Mirror		2	
3	Windshield		1	
4	steering wheel		1	
5	Car body		1	
6	Wheels		4	

7	Wheels cover		4	
8	motors			6V 4.5Ah battery one motor 12V 4.5Ah battery two motors
Spare parts				
1	M10 nut M5*35 Round screw		4	Check in Spare parts bag
3	Ø4*20 self tapping screw		4	Check in Spare parts bag
4	axle sleeve		8	Check in Spare parts bag
5	Gasket		8	Check in Spare parts bag
6	Charger		1	
7	Controller			
8	Manual		1	

Assembly steps

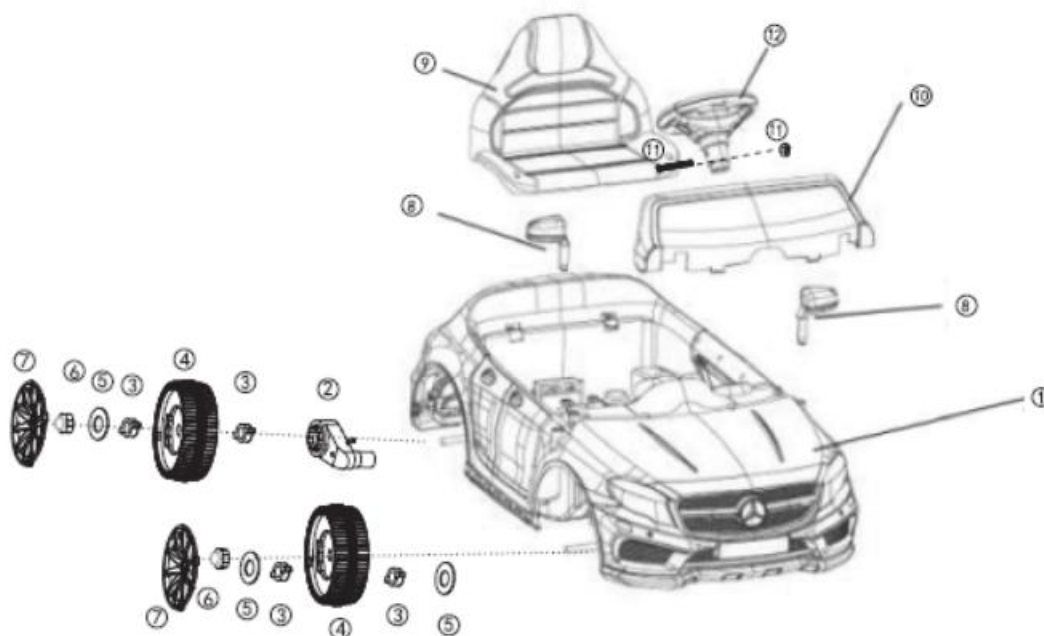

① Car body ② motors ③ axle sleeve ④ wheel ⑤ gasket ⑥ nut ⑦ wheels cover

⑧ mirror ⑨ seat ⑩ windshield ⑪ M10 nut, M5*35 round screw ⑫ steering wheel



Warning

The toy should be used with caution since skill is required to avoid falls or collisions causing injury to the user or third parties.

• The vehicle must be assembled by adults, which needs about 10 minutes.

• Tools needed: a screwdriver( prepared by yourself)



(2pieces check in the spare bags)

- Don't let children touch or play the small components so as to avoid children being choked.
- Please check the packing list before assembling. Deal with the plastic bags properly and don't let children play the bags so as to avoid them being choked.

Driving wheel installation:

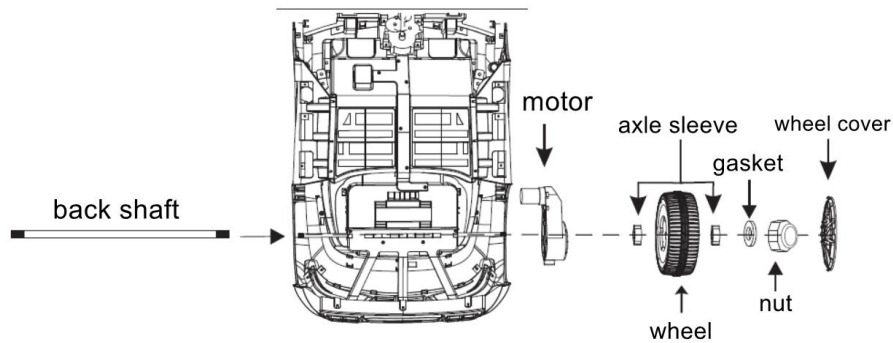

- Turn the bottom of the toy car up as above picture show.
- Put a axle sleeve and a gasket into the wheel.
- Push the wheel to the back axle and make the wheel connect well with the motor.
- Put a axle sleeve and a gasket to the other side of the wheel
- Tighten the wheel with a M10 nut.
- Insert the Wheels cover.
- The other wheel to be installed as the same way.

(6V 4.5Ah battery one motor, 12V 4.5Ah battery two motors)

Front wheel installation:

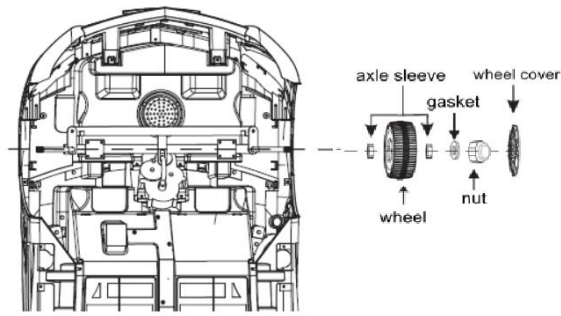

- Turn the bottom of the toy car up as above picture show.
- First put a axle sleeve and a gasket into the wheel.
- Push the wheel to the front axle.
- Put a axle sleeve and a gasket, then tighten them with a nut.
- Insert the Wheels cover.
- The other wheel to be installed as the same way.

Driving wheel installation

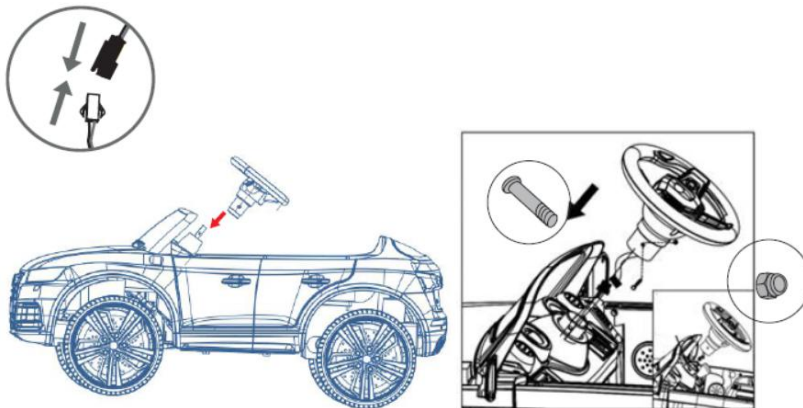

- Connect the terminal of the steering wheel to terminal of the instrument panel , put the wire back to instrument panel if they are too long.
- Make the two holes of the driving wheel connect with the holes in the instruments panel, and then tight M5 nut well with M5*35 round nut.

Mirror installation

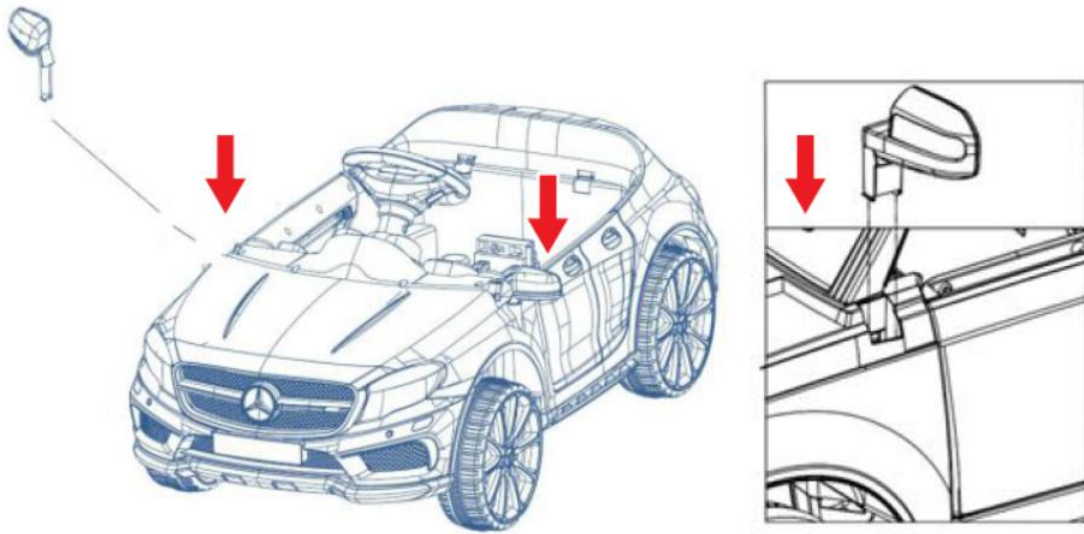

- Make the slots in the mirror in the same line with the slots in car body and press the mirrors into the gaps.

Windshield installation

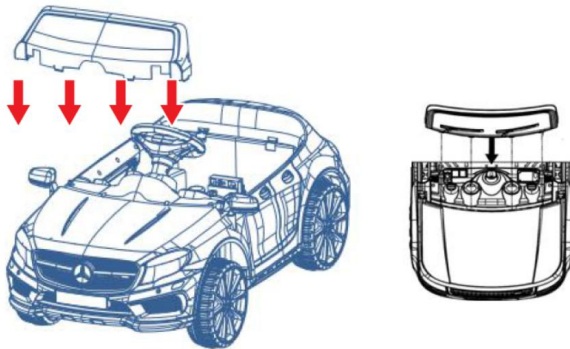

- Check the slot and press the windshield according the slot location to the gap end.

Seat installation

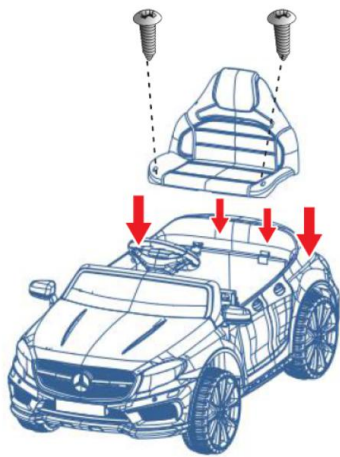

- Put the seat onto the car body according to above picture, and tight the seat with slots well using $\text{Ø}4 \times 20$ self tapping screw.

Connect the wire

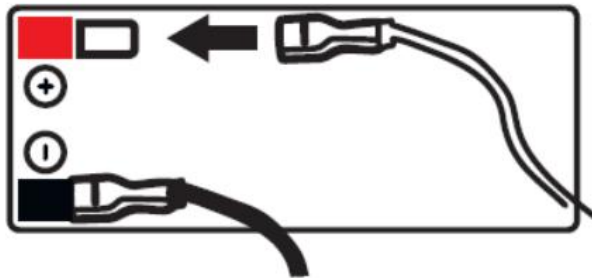

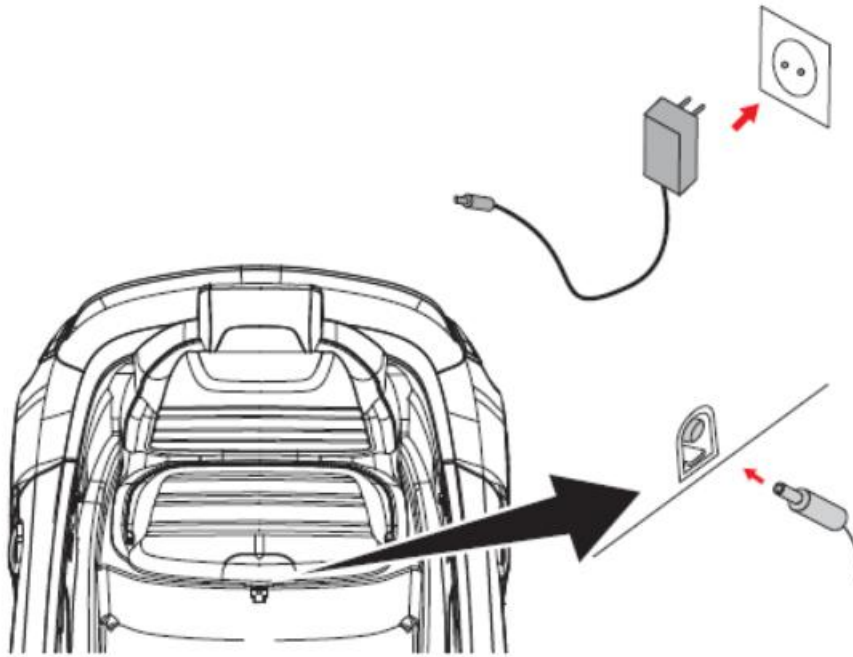

- Take off the black plastic protective jacket. Connect the red line on the car body connect with the red line of battery.

Note:

Pay attention to the positive and negative positions to prevent short circuit of the power supply.

How to operate your“Ride on”

- Please tell your children and his playmates with the following safety rules and make sure they all understand.
- The car should be driven under the supervision of adults
- When driving, must wear a helmet and wear shoes and must sit on the seat.
- Make sure your child drives the vehicle in a safe driving environment, such as home, a garden or a playground.
- Make sure your children is within the limit of weight and age.
- Do not touch the wheels or get close to a running vehicle.

●Check the vehicle's wires and connections, do not change the original design.



①Player: with USB, MP3, TF card Jack, powder quantity display.

②Light switch: Turn on or off the light.

③Powder button: to turn on or off the powder.

④Forward/backward switch: Operate it together with the accelerator to make the vehicle to go forward/backward.

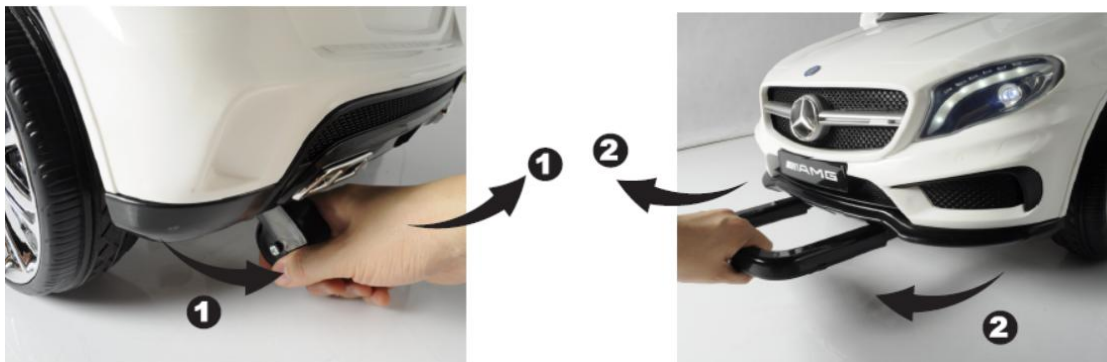

When the ride on toy car is out of powder, you can push it home with the help of small wheels and handle.



When your child is go out of the car, please open the door buttons like above pictures show.

And when the child is driving, please do not forget to lock the doors with above buttons.

How to use Controller



WARNING

Non-rechargeable batteries are not to be recharged;
Different type of batteries or new and used batteries are not to be mixed;
Batteries are to be inserted with the correct polarity;
Exhausted batteries are to be removed from the toy;
The supply terminals are not to be short-circuited.
Rechargeable batteries are only to be charged under adult supervision;



AAA 1.5v



- Open the battery cover on the back of the remote control and load two 1.5V AAA batteries (battery prepare by yourself)
- Cut off the power of the vehicle.

- Press the code button for about 10 seconds and open the vehicle powder to make the controller connect with the vehicle.
- Just first time need this step, in the future using no need.
- Turn the “remote control/ foot switch” on the vehicle to “remote: position.
- Press the remote control “forward” button, make the vehicle go forward. Without operation the remote control, the car will stop moving.
- Press the “left” button of the remote control to turn the vehicle to the left; press the “right “ button of the remote control to turn the vehicle to the right.
- Press the “speed up” button, the speed will be up.
- Remote control button automatically open, without touching about 2 minutes, it will shut down automatically.

Note: There are three kinds of controller, the one with your vehicle maybe different from above picture.

Charging the battery



WARNING

Battery charger used with the toy are to be regularly examined for damage to the cord, plug, enclosure and other parts, and in the event of such damage, they must not be used until that damage had been repaired.

Note:

The car is equipment with a charge protection function, when charging all the functions of the cars are not available.

- When charging, the power switch must be turn off.
- The first time use, the proposed charge time is 4-6 hours, but no more than 20 hours.
- If the normal speed of the vehicle is slow down, indicating that the battery power is low, please charge in time.
- After each use, please charge 8-12 hours, but no more than 20 hours.
 - a. Insert the charger plug into the charging hole.
 - b. Make the charger plug into a power socket.

Trouble shooting guide

Trouble type	How to check it	How to solve
The motor doesn't work	1. Is it caused by the overload fuse (fuse is in the box under the seat)	If yes, change a new fuse. There is a spare one in the fuse box. If not, then check the next.
	2. Is the foot switch well connected?	If no, repair the food switch, If yes, check the next.

	3. Are the wires welded well on the ends of motor	If no, weld well. If yes, check the next.
	4. Take apart the plug-in of the motor and connect with the battery directly	If still not work, change the motor. If work, driving circuit board need professional repair, please contact with your supplier.
The vehicle cannot move forward or backward	1. Check the forward/backward switch with a muti meter and see if it is normal	If no, change the switch. If yes, check the next.
	2. Are the driving circuit board connect well with forward/backward switch?	If no, connect the wires well. If yes, the driving circuit board is broken, contact with your supplier.
The vehicle moves slowly	1.Is the voltage of the accumulator over 10V?	If no, charge. If yes, see the next.
	2.Will the vehicle moves faster when the motor(with gear box) is connected directly with the accumulator?	If yes, the driving circuit board is broken, contact with your supplier. If no, check the next.
The accumulator cannot be charged	1. Are the connectors of the accumulator loose or dropped	If yes, connect well. If no, check the next.
	2. Is the charger a little hot when charging?	If yes, the charger is broken change a new one.
The vehicle is normal but without light and sound	1. Is the sound and light switch in good condition?	If No, change the switch. If yes, check the next.
	2. Check the wires and the connectors from the head to the accumulator and see if they are in good condition	If no, connect them well.
Wheels doesn't work	1. Is the driving wheel move well	If yes, let the wheels touch ground. If no, check the next.
	2. Check the gearbox, to see if the gears at all levels are damaged	If yes, change a new gearbox.
The vehicle often stop when moving	1. Is the vehicle overload than 30KG?	If yes, its normal. If no, check the next.
	2.Is the road the car is driving is not flat	If yes, drive on flat road. If no, check the next
	3. Can the free wheels be turned freely	If no, then wheel and axle have no problem.
If you cannot solve the problems following above steps, please contact with your supplier.		

Maintaining your “ride on”

- Parents should check the vehicle’s main parts are all in good condition before each time your kids driving. To check whether the charger, plug, vehicle shell are broken or not and whether the bolts are loose or not. If there are something wrong please repair it before using.
- After driving for a while, please wipe some lube on the iron parts to prevent getting rusty. Keep away from fire and the sun for a long time. The car should stop in level position, should not be bottom up, or in a sloping position. In raining days, put the vehicle in house or cover it well.
- Keep away from high temperature items, like stove, heater, because the plastic parts will get melt.
- When charging, please stay away from inflammable article to prevent fire.
- Please charge in time. And the charge must be done by adult, if do not using for a long time please charge full. And also charge once each month to extend the life of the battery.
- Clean the vehicle with soft cloth to make the surface clean and shining. Do not use chemical solvent, soup to clean the vehicle. Do not drive the vehicle in rain and snow condition, because the water will damage the motor, circuit diagram and also the battery.
- When you stop using or leave it unused, turn off the power of the vehicle and set all switches to the "Stop" or "Off" position.
- Do not use fuses that do not comply with this product. Do not arbitrarily change the structure of the product and the line system, maintenance work must be professional or under the guidance of technical staff.

Wiring diagram

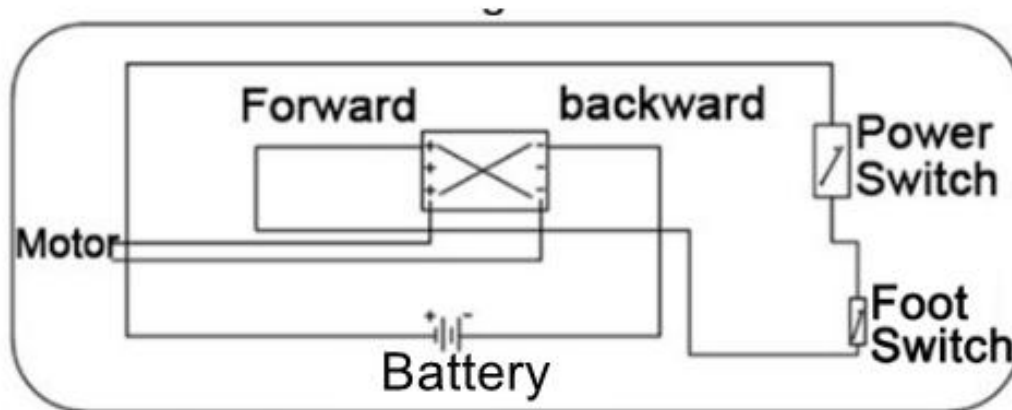

Disclaimer

- We will not take responsibility if you change the circuit, structure or function of the vehicle.
- The diagrams in this manual are for showing the operating method and the structure of the vehicle. If there are some differences between the pictures and the real vehicles, please refer to the real vehicle.

- In order to improve the quality, we may change some parts of the structure or its appearance without notice in advance, hope you understand and support.
- This manual is very important, please take care of.