

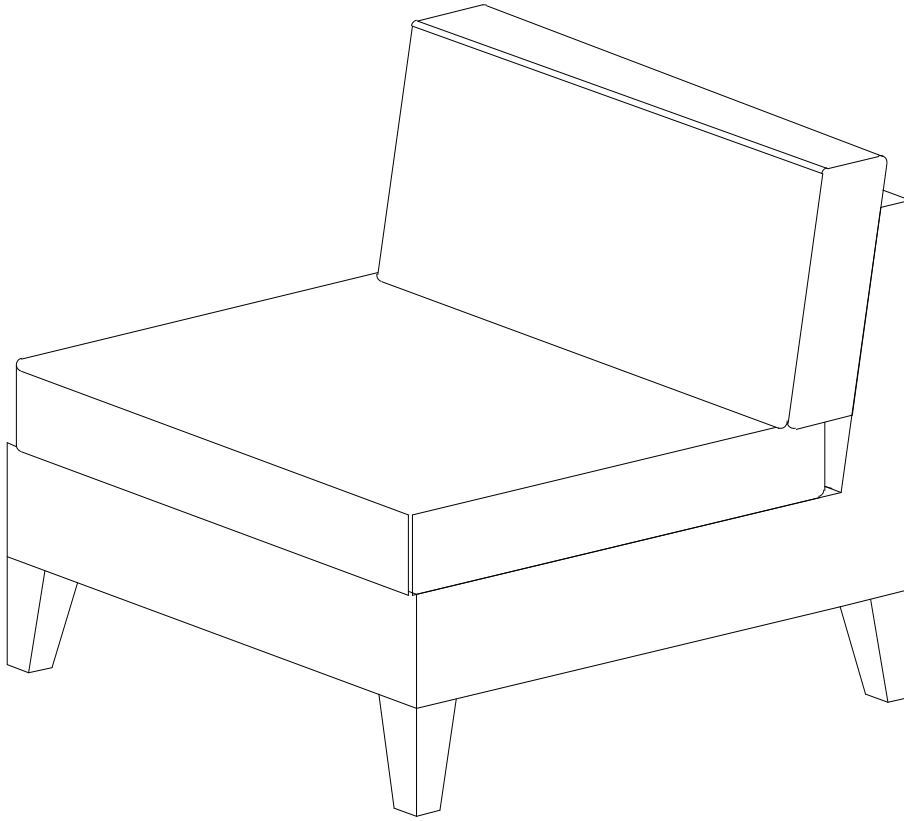







# Assembly Instructions

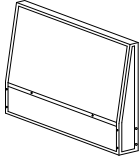

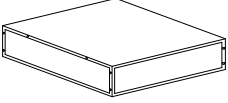
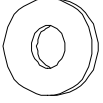
**\*Don't fully tighten all the bolts till the very end!**

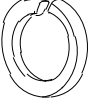
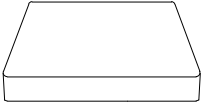
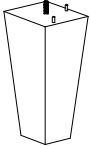

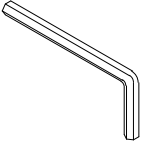
## PRE-ASSEMBLY PREPARATION:

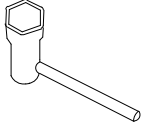
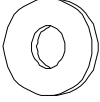
- Please read through the instructions before beginning assembly.
- Clear out the space for assembly and lay out all of the parts based on the Parts List, extra room will allow you to easily determine if all the pieces are present.
- Keep small parts and pieces away from children until fully assembled.

Part no.	Part	QTY	Image	Part no.	Part	QTY	Image
B	Back	1		I	Nut M8	4	
C	Seat	1		J	Washer Ø18*Ø8.5*1mm	4	
D	Back cushion	1		K	Spring washer Ø8.5mm	4	
E	Seat cushion	1		L	Leg	4	
F	Bolt (M6*30mm)	4		M	Allen Wrench	1	
G	Bolt (M6*40mm)	2		N	Wrench	1	
H	Washer Ø16*Ø6.5*1mm	6					

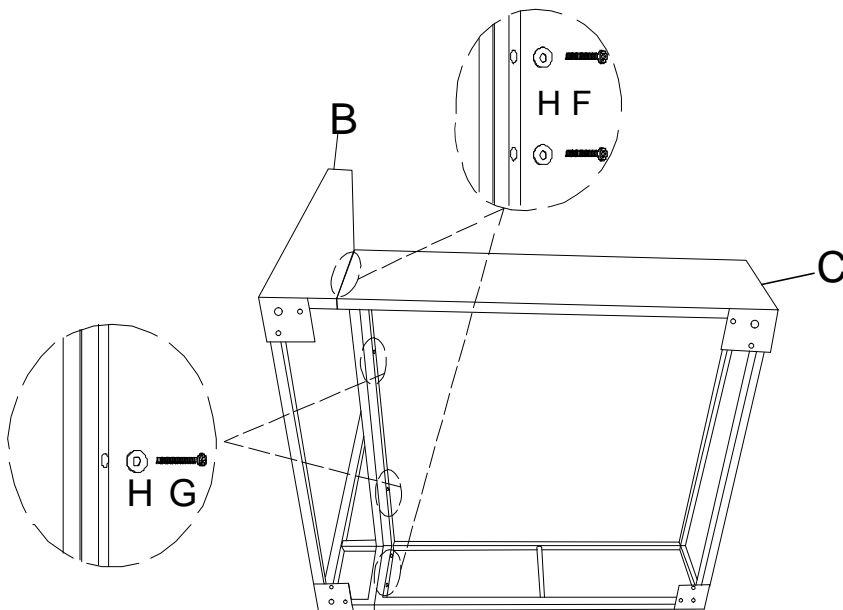

**Step 1:** Attach seat C to back B with 4pcs bolts F, 2pcs bolt G and 6pcs washers H, using Allen wrench M.

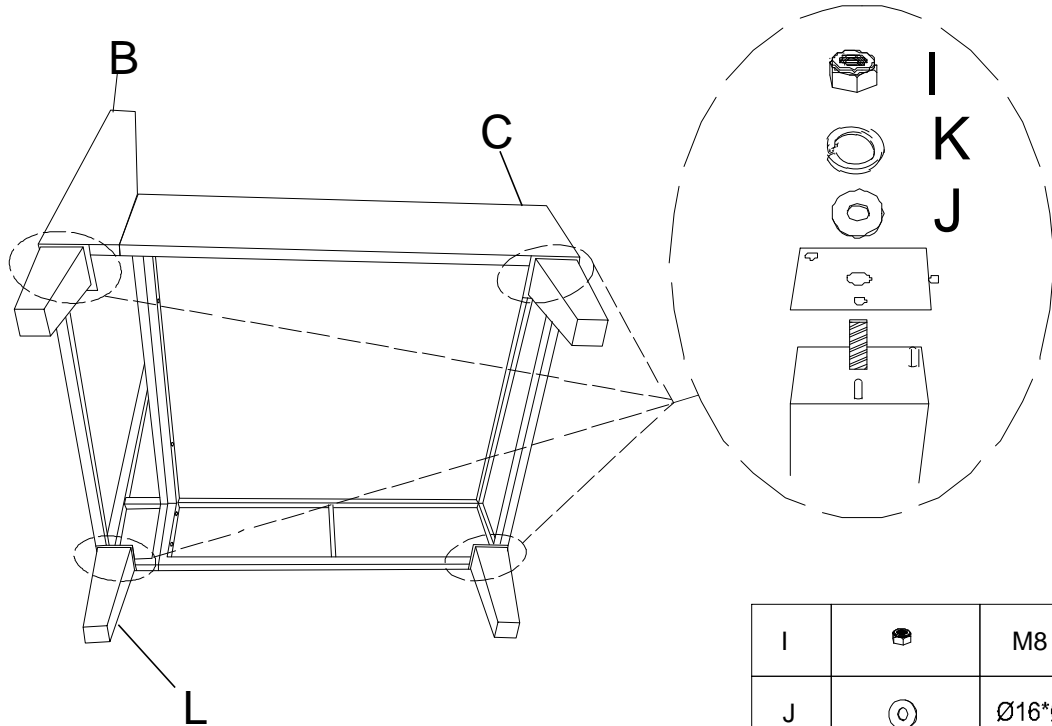

F		M6*30	4
G		M6*40	2
H		Ø16*Ø6.5*1	6

**Step 2:** Attach legs L to back B and seat C with 4pcs nuts I, 4pcs washers J and 4pcs spring washers K, using Allen wrench M and wrench N.



I		M8	4
J		Ø16*Ø8.5*1	4
K		Ø8.5	4

**Step 3:** Put seat cushion D and back cushion E onto the seat. Assembly is now complete and the product is ready for use.

