

Assembly Instructions

Caution : You must read this before you proceed

BARSTOOL





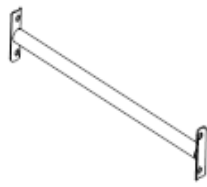
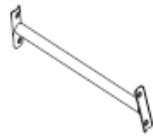
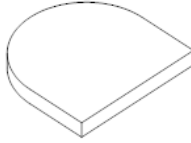

Part List

Label	Picture	Description	QTY
A	A line drawing of the seat part of the bar stool, showing the curved backrest and the seat.	Seat	1
B	A line drawing of the left leg of the bar stool, showing the vertical leg and the horizontal bar connecting to the front leg.	Left Leg	1
C	A line drawing of the right leg of the bar stool, showing the vertical leg and the horizontal bar connecting to the front leg.	Right Leg	1

D		Front Foot Rest	1
E		Back Foot Rest	1
F		Seat Cushion	1

Hardware

Label	Picture	Description	QTY
①		Bolt(M6*20MM)	13
②		Washer	13
③		Allen Key	1
④		PE Cap	9

Assembly Preparation

Before Beginning Assembly:

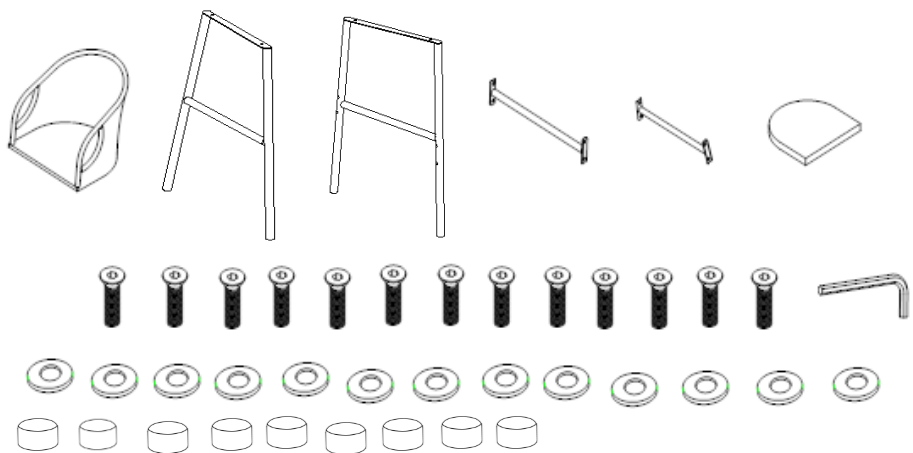

- Read instructions, cover to cover-



- Have 2 adults on hand for assembly-



- Do not assemble on flooring or carpet-



- Assemble on a clean non-marring surface (packing foam)-



- Save all packaging until finished-

Assembly Steps

Overview

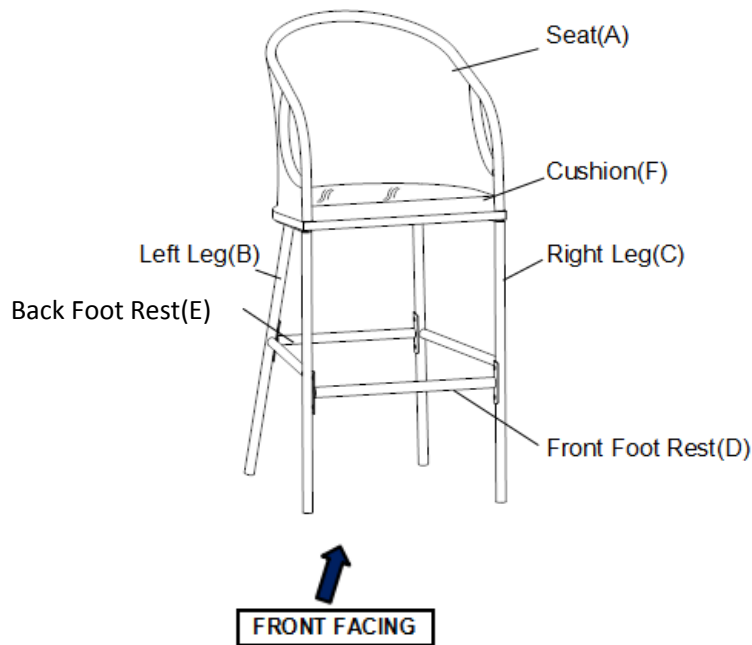

This Barstool has multiple parts and may require up to 30 minutes to assemble. To give you an overview of the Barstool parts, the above picture is to help you put the various parts into perspective. Please read through the instructions below to familiarise yourself with the parts and steps before assembly.

Step 1

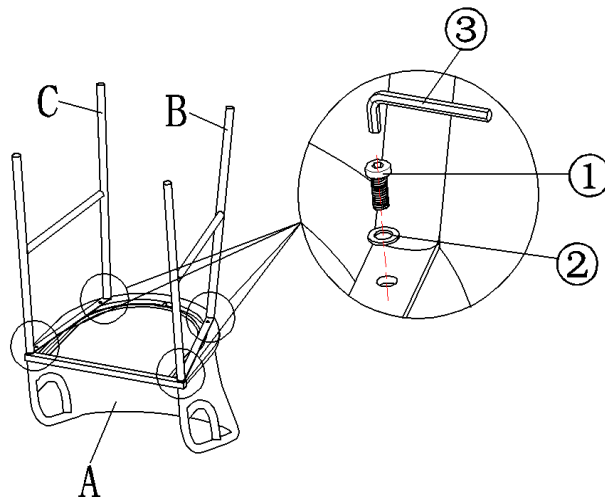

Open the carton and place all the parts onto a clean, non-marring surface. Attach Left Leg(B) and Right Leg(C) to Seat(A) using Bolts(①) and Washers(②) with Allen Key(③) as pictured.

Do not fully tighten the Bolts.

Occasionally some of the PE Wicker shifts and covers the mounting positions preventing easy assembly. The PE Wicker should never be cut, but moved away from the mounting positions.

Step 2

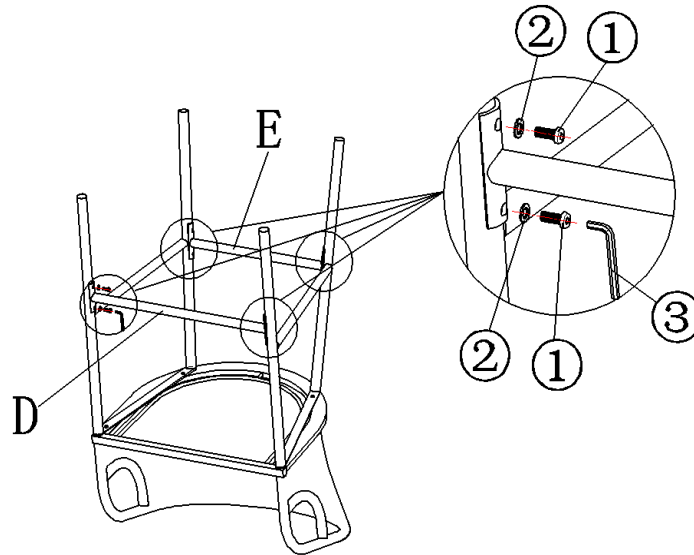

Place the Front Foot Rest(D) and Back Foot Rest(E) between the Left Leg(B) and Right Leg(C).

Attach Front Foot Rest(D) and Back Foot Rest(E) to Left Leg(B) and Right Leg(C) using Bolts(①) and Washers(②) with Allen Key(③) as shown in the picture.

Tighten all Bolts at all joints sequentially.

DO NOT tighten any Bolt fully and then move onto the next one. This may cause the frame to warp.

Step 3

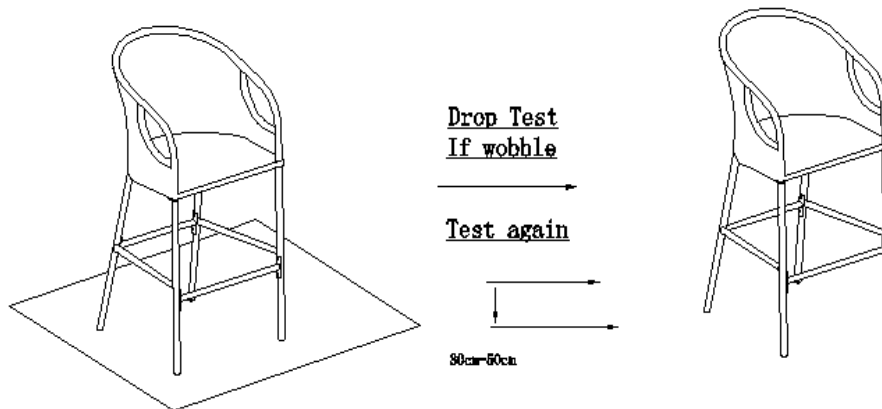

Place the Barstool on a LEVEL SURFACE to check for wobbles. If it wobbles, lift the Barstool some 30cm to 50cm high from the ground. Keep your feet and toes well away from the drop zone. Drop the Barstool freely and vertically with all four legs, hitting the ground, at the sametime. This Drop Test will help to ensure that all the Bolts and gaps reach full alignment status. Test again for evenness on a LEVEL SURFACE. If no wobbles are found, slowly and steadily, place the Barstool facedown. Then, proceed to tighten all Bolts in a sequential manner. When tightening the Bolts, tighten sequentially. DO NOT tighten any Bolt fully and then move on towards the next one. This could cause the frame to warp. If there are still wobbles, loosen the Bolts and execute the same drop test.

If the Barstool is not stable, it could lead to damage to the product.

Step 4

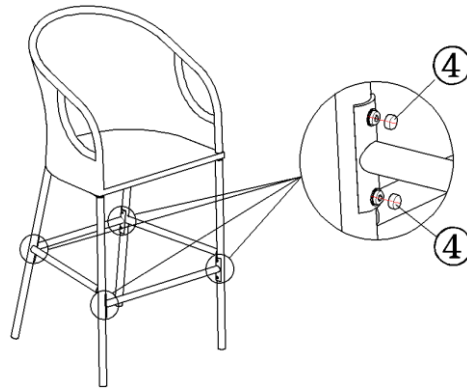

Put the PE Cap (④) on the screw, as the picture above.



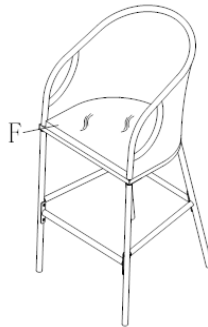

















Step 5



Put the Seat Cushion(F) on the Barstool.
Your Barstool is ready for use.

This Barstool can only be used on the flat, level surface.

Care & Maintenance

-   ● Do not put hot items directly on furniture surface
 -   ● Do not clean furniture with harsh cleansers or polish.
 -   ● To obtain the longest lifespan of your outdoor products, minimizing exposure to direct sunlight is recommended.
 -   ● Children should not climb or jump on the furniture.
 -   ● Do not write on furniture without a padded barrier to protect the surface.
 -   ● To obtain the longest lifespan of your outdoor products, avoid extended and lengthy exposure to rain, snow, and direct sunshine. Whenever possible cover the product and /or place under patio or awnings.
 -   ● Not for commercial use. For residential use only .
 -   ● Stains may be removed with mild soap solution and damp cloth.
 -   ● Keep away from sources of ignition.
-
-   ● Dust and pick-up spills using a clean, non-colored, lint-free cloth .
-