

WALKER EDISON
TM

MIA MODULAR TALL CABINET

SKU# WEMIA31362

LOT: AYYWW-XXX



For Residential Use Only

Please visit our website for the most current instructions, assembly tips, report damage, or request parts. www.walkeredison.com

WE Time to get started

Set up a clean and soft workplace to avoid damage during assembly. You can use the box and internal protections as a cover. It also helps to double-check if you have got all the pieces and parts before diving into the assembly.

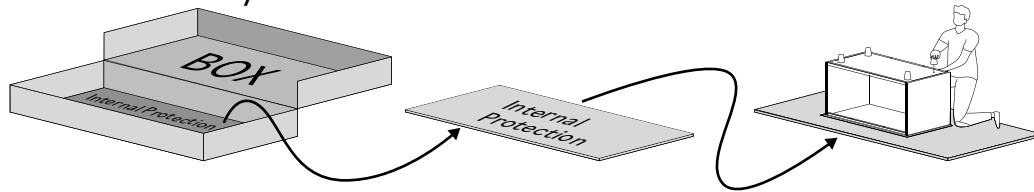

**Estimated time
for assembly**

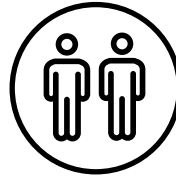

2 People Build

**People recommended
for assembly**

Make it a team effort!
Grab a friend for quicker,
easier assembly.

Tools Needed

Grab a Phillips screwdriver to conquer this assembly.

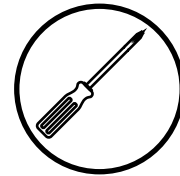

Use power tools with caution

This furniture is made of Solid Wood and Composite Wood, soft materials. If you choose to use power tools, set it to the slower setting. Be careful! Power tools can cause cracking or damage to the furniture, they can also damage the hardware if misused.

Power tool damages are not covered by the Walker Edison warranty.

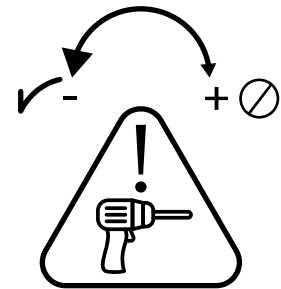

Scan to get assembly tips and help!



Parts List

Part Number	Description	Quantity
01	Bottom Panel	1
02	Left Panel	1
03	Top Panel	1
04	Right Panel	1
05	Shelf	1
06	Back Panel	1
07	Foot	5
08	Door	2
09	Glass Door Front	2
10	Top Rail	1
11	Shelf Rail	1

WALKER EDISON

Distribution and responsible for the anti-tip hardware:
Walker Edison Furniture Company
1553 W 9000 S, West Jordan,
UT 84088 United States

For details on Assembly Videos. Assembly Instructions.
Replacement Parts and Customer Service. SCAN HERE.

Collection Name







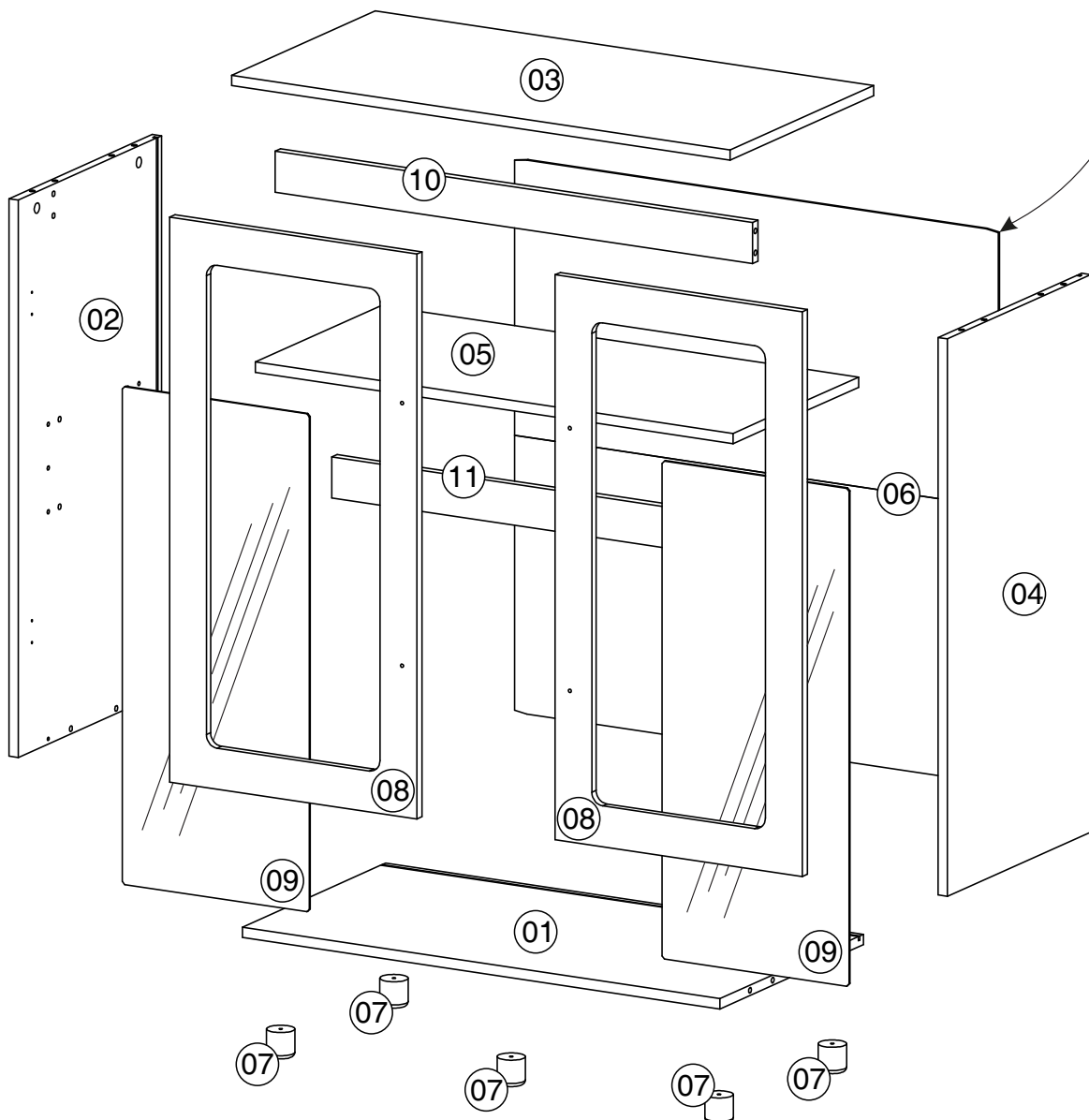

Model: XXXXXXXXFF
LOT: AAYYWW-XXX
Date: MM/20YY
Rev. MM/20YY-VX

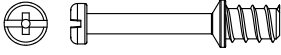
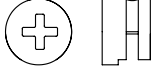
CANFER compliant / conforme au CANFER
TSCA Title VI compliant / conforme au titre VI de la TSCA
TSCA Title VI certified / certifié conformément au titre VI de la TSCA
California 93120 Compliant for Formaldehyde /
Conforme à la norme Californie 93120 pour le formaldéhyde.

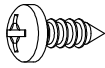
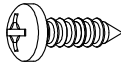
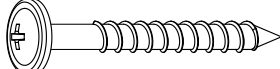

WE Hardware List

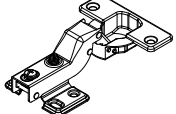
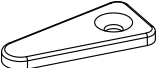
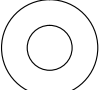
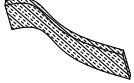
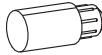
Part	Size	Name	Quantity
A	 8x30mm	Wooden dowel	14
B	 Ø7x30mm	Cam Bolt	11
C	 Ø15x10mm	Cam Lock	11
D	 Ø3.5x12mm	Screw	20
E	 Ø3.5x25mm	Screw	4
F	 Ø4x14mm	Screw	24
G	 Ø4x20mm	Screw	5
H	 Ø5x40mm	Screw	5
I	 Ø3x16mm	Screw	8
J	 Ø 19mm	Sticker	19
K	 14.7x30mm	Support	8
L	 224mm	Handle	2
M	 Ø35mm	Metal Hinge	4
N	 25x12mm	Door Latch	20
O	 1/4x5/8	Washer	02
P	 20x200mm	Wall Anchor	01
Q	 6x18mm	Shelf Support	04

*The hardware quantities listed above are required for proper assembly.
Extra hardware pieces may be included.*

Step 1

Let's get started! Insert Wooden Dowels (A) into Bottom Panel (1), Left Panel (2), Right Panel (4), Top Rail (10) and Shelf Rail (11). Also, attach Cam Bolts (B) to Left Panel (2), Top Panel (3) and Right Panel (4) using a Phillips screwdriver.

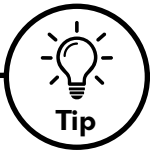
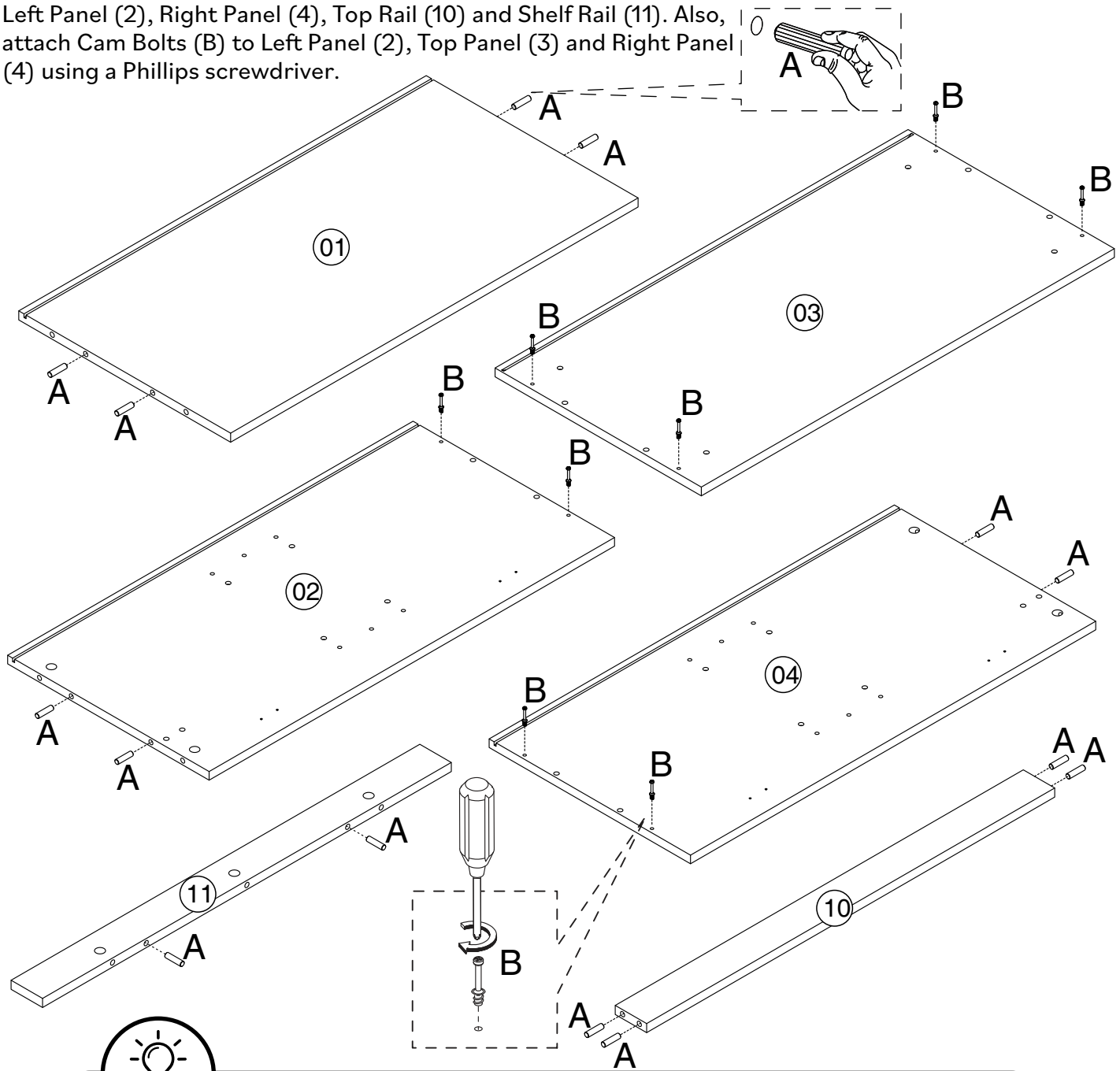

Wooden Dowels

Dowels are essential in furniture assembly to create strong, precise connections. They ensure structural integrity, prevent shifting, and simplify alignment, resulting in sturdier, longer-lasting furniture.

Follow these steps:

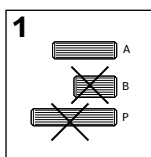

1: Select the appropriate size dowel according with step.

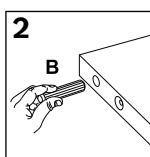

2: Insert into drilled hole and press firmly to ensure placement is set.

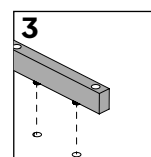
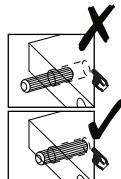

3: Align the dowel with corresponding piece and press together until secure.

Step 2

Attach Hinges (M) to Doors (8) using Screw (F) and a Phillips screwdriver.
Insert Glass Door Front (9) in Doors (8) and secure using Door Latch (N), Screw (D) and a Phillips screwdriver.

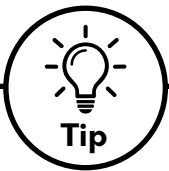
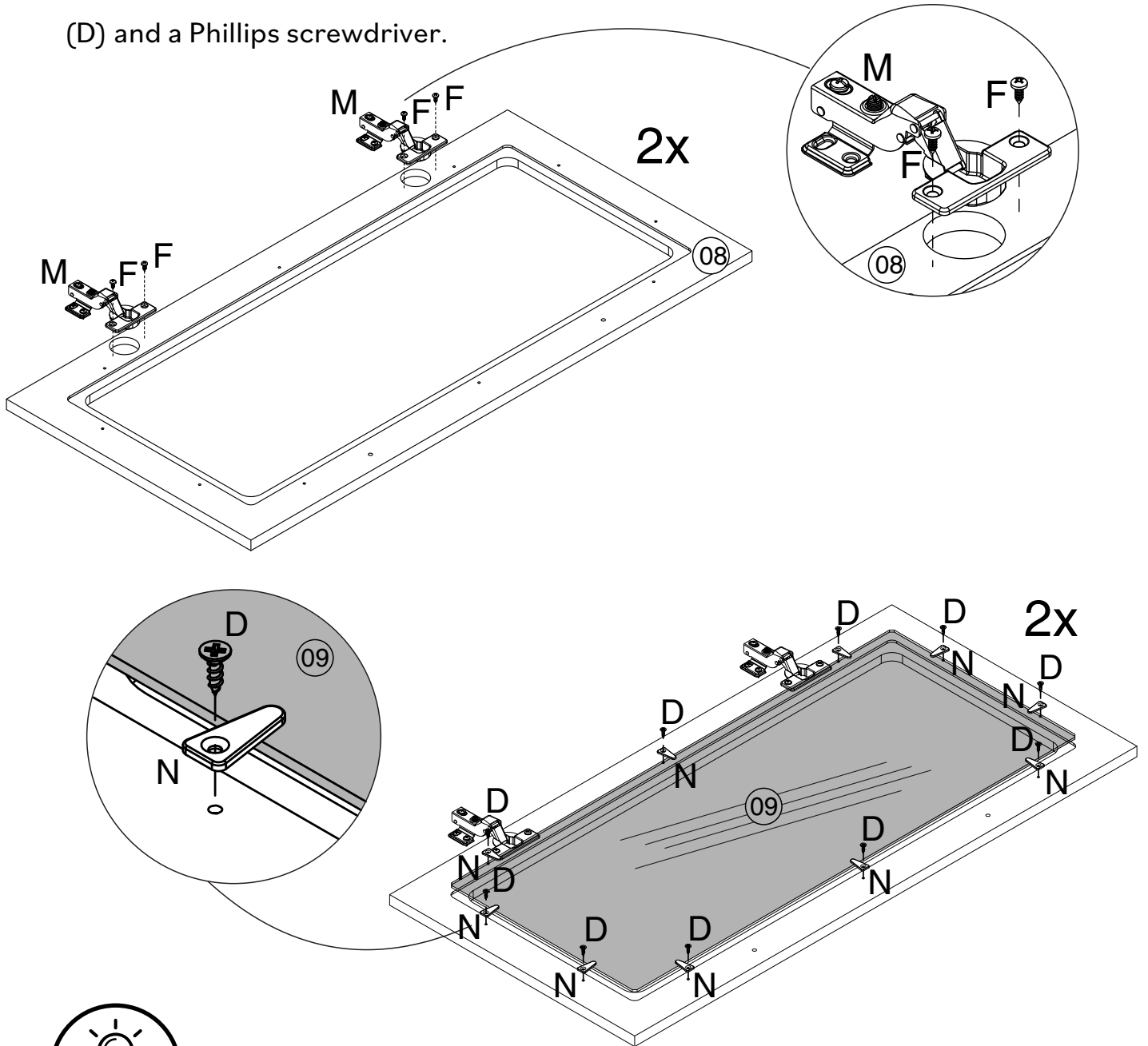

To keep your product looking its best and scratch-free, try assembling it on a soft surface like carpet or a blanket. This helps prevent any accidental scratches and keeps your furniture in top shape!

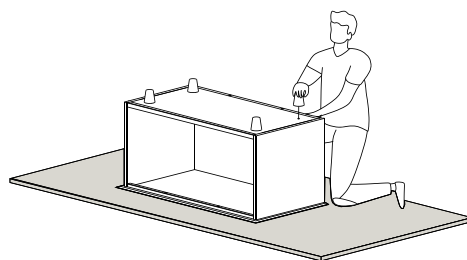

Step 3

Join Bottom Panel (1) and Left Panel (2) using Cam Locks (C) and a Phillips screwdriver.

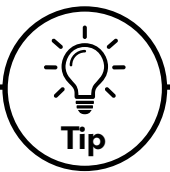
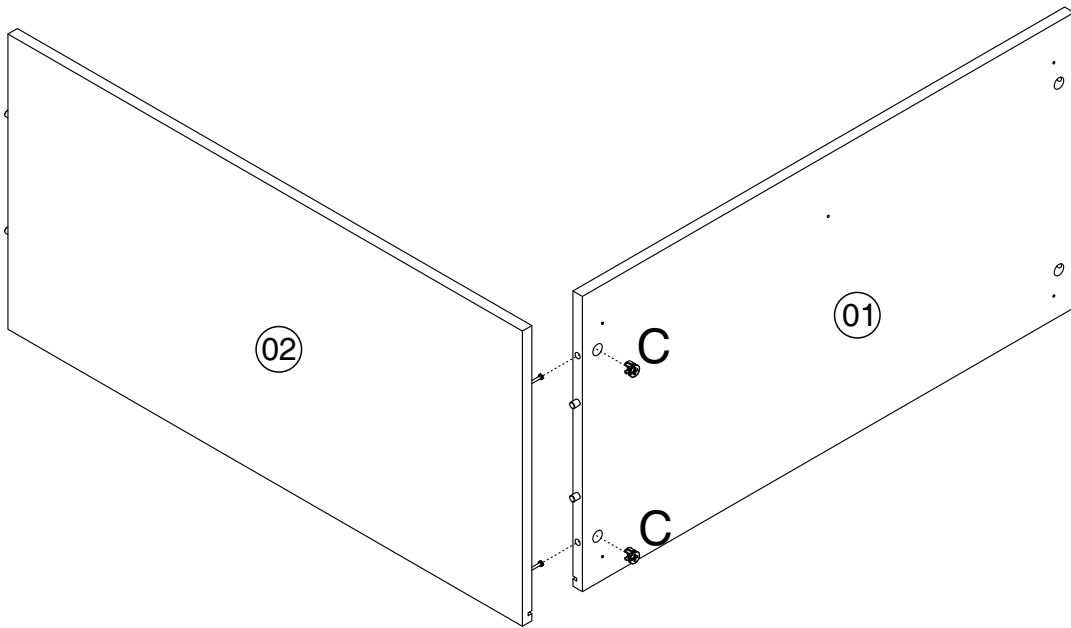

Cam Locks

Cam Locks help to securely join two pieces together.
Follow these easy steps.

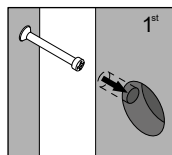

1: Insert Cam Bolt into bolt holes on the flat side. Don't over tighten!

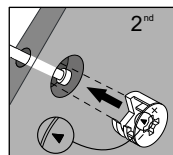

2: Assemble both parts together. The cam bolts go in the drill holes that have a circular hole on the side, you should be able to see the cam bolts through it. After fitting parts together insert the cam lock on the side holes.

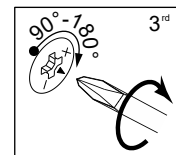

3: On the back of the Cam Lock will be a "C" shape. Insert the Cam Lock so the opening of the "C" fits over the Cam Bolt. Tighten with

Step 4



Secure Top Rail (10) and Right Panel (4) using dowels, Cam Locks (C) and a Phillips screwdriver.

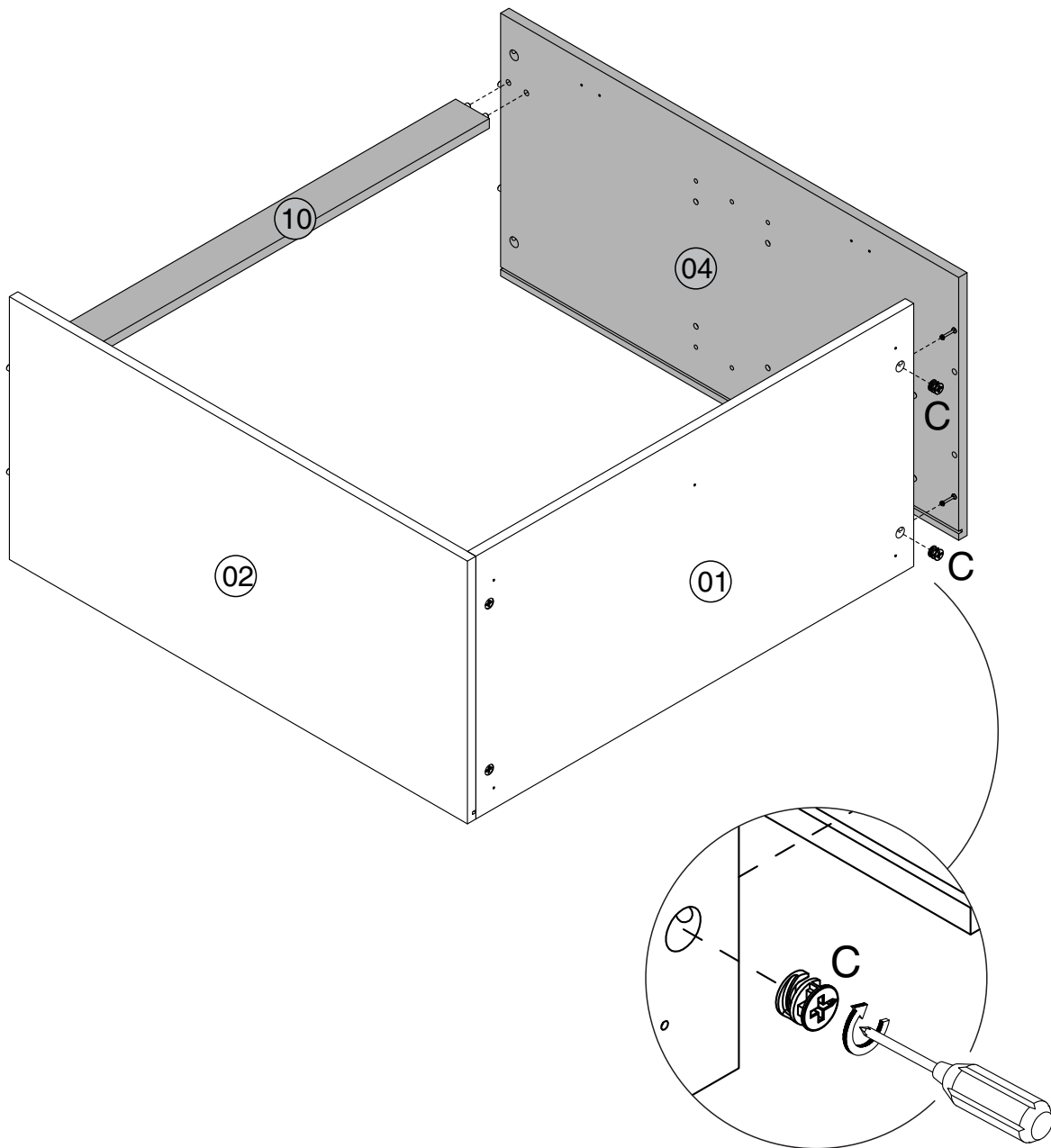

Step 5



Slide Back Panel (6) between the grooves on Left Panel (2) and Right Panel (4) fitting in Bottom Panel (1).

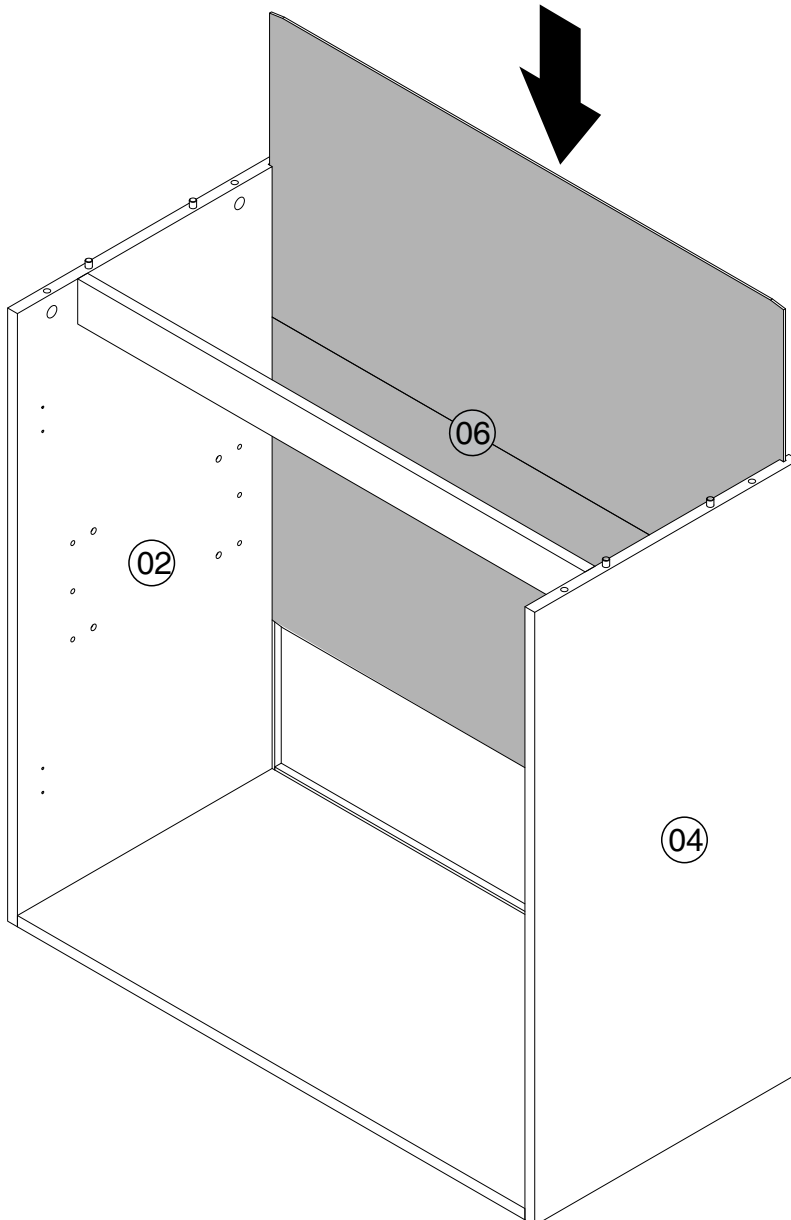
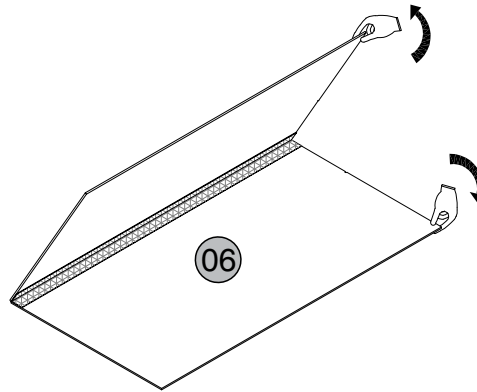

Step 6

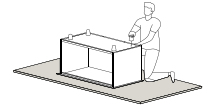

Attach Top Panel (3) to Left Panel (2) and Right Panel (4) using Cam Locks (C) and a Phillips screwdriver.

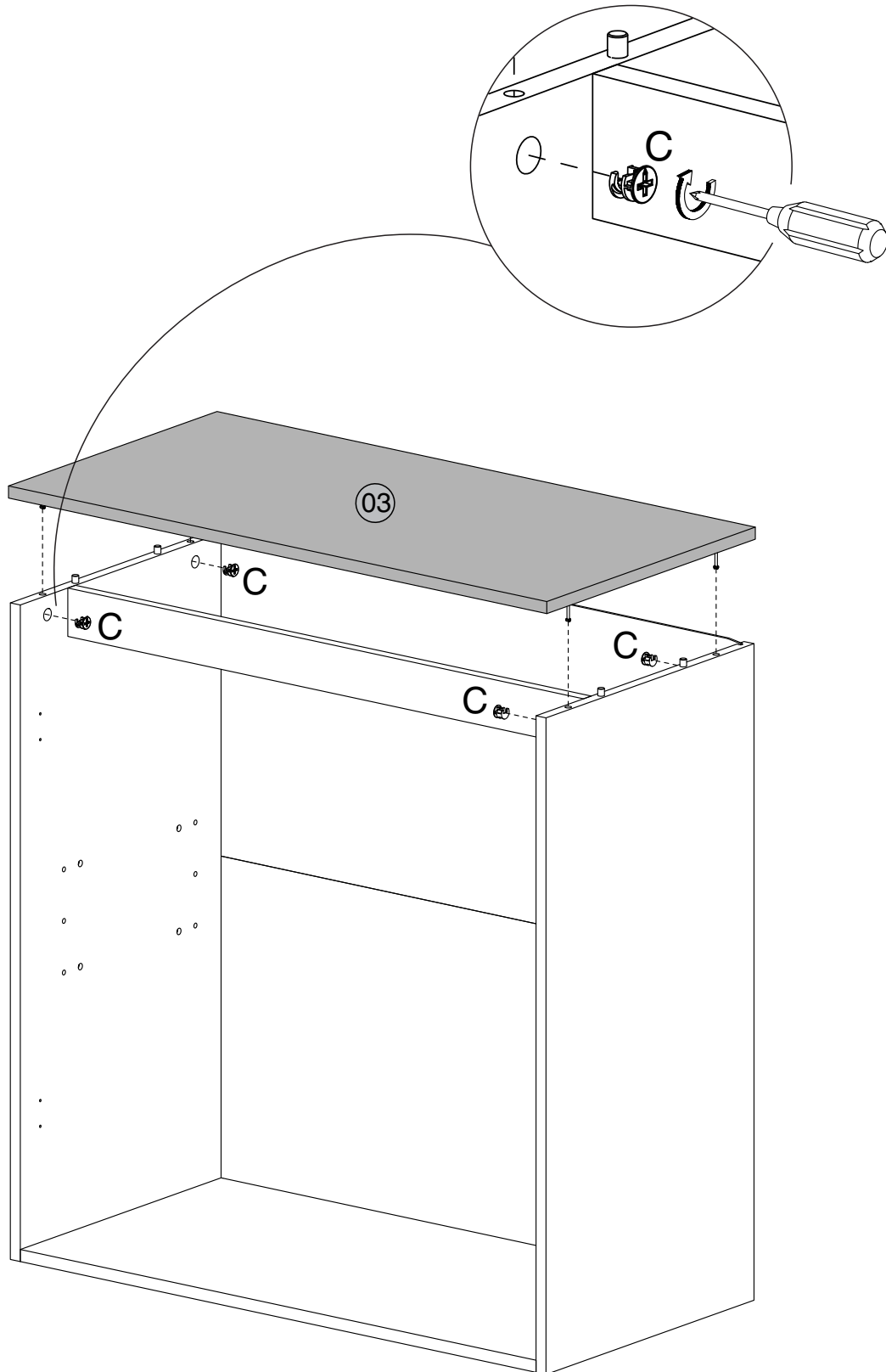

Step 7



Secure Shelf Rail (11) to Shelf (5) using Cam Locks (C) and a Phillips screwdriver.

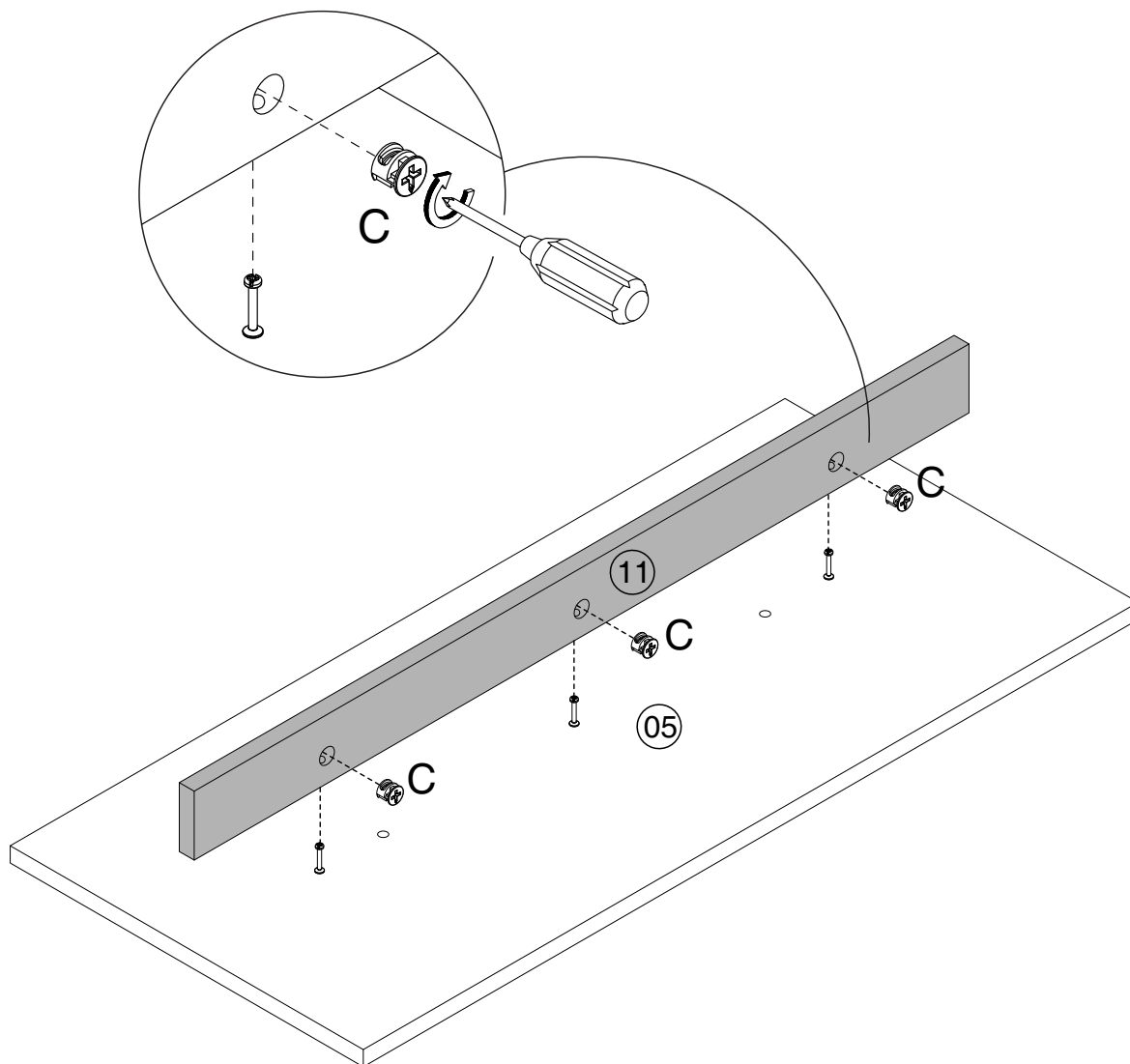

Step 8

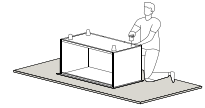

Insert Shelf Support (Q) on the holes in the middle of Side Panels. Then, place Shelf (5).

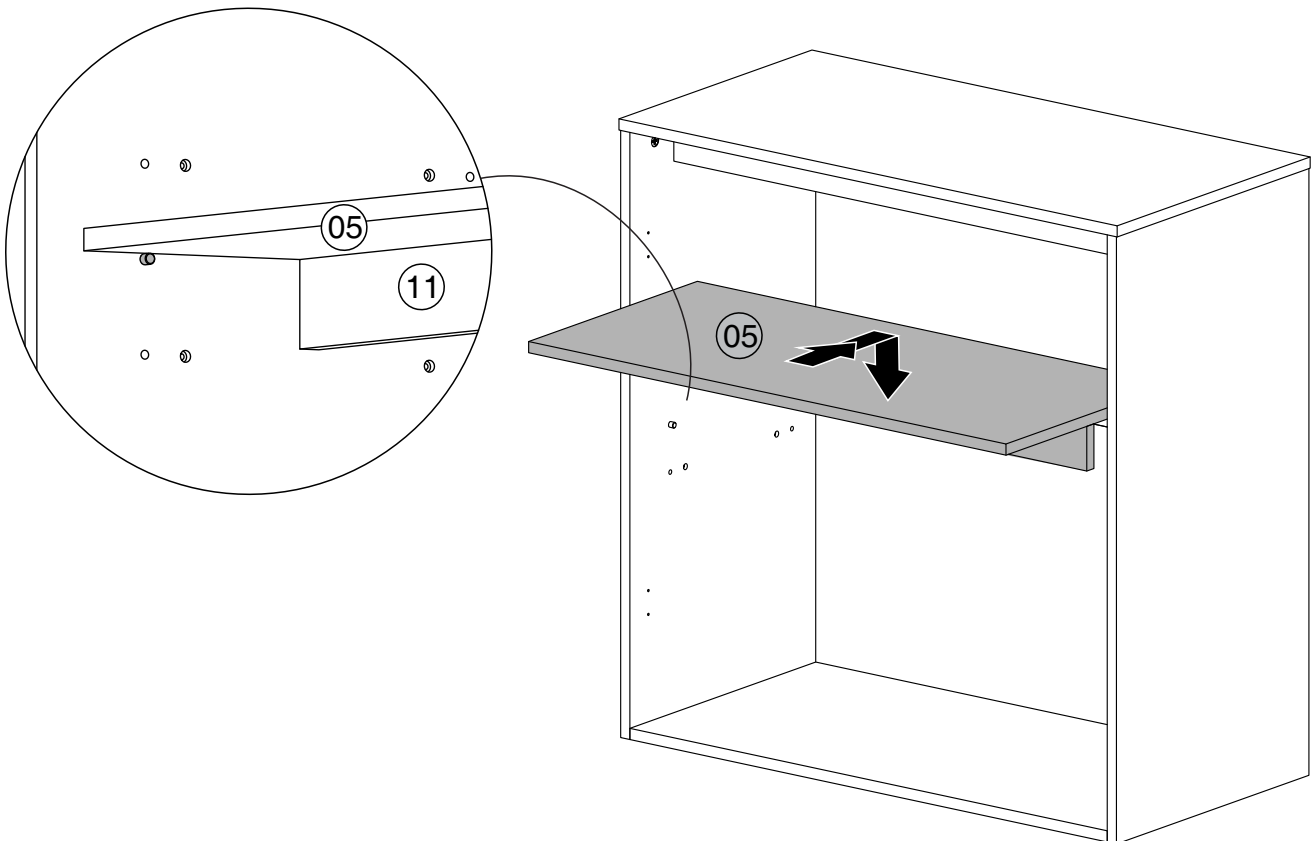
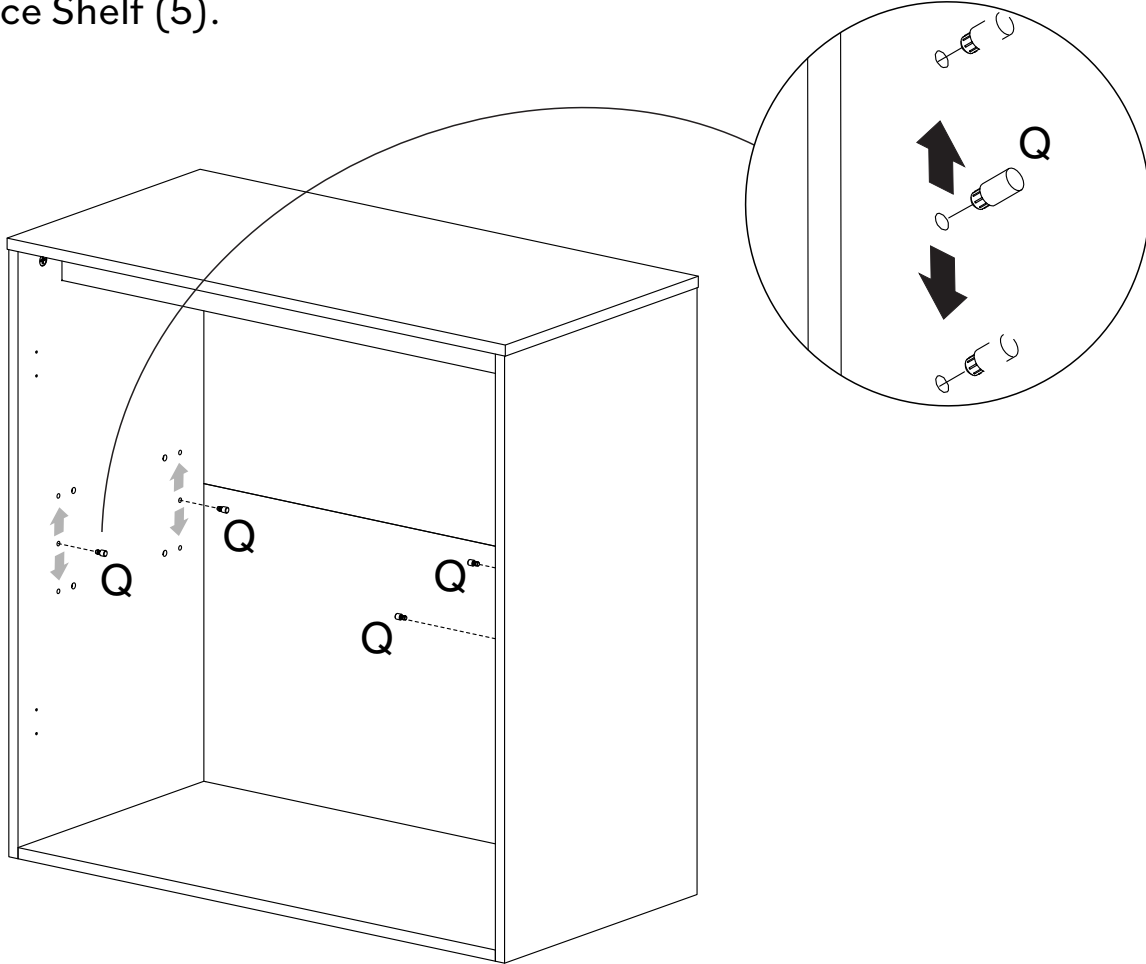

Step 9

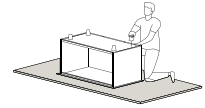

Attach Door (8) on Left Panel (2) using Screws (F) and a Phillips screwdriver.

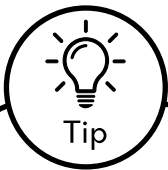
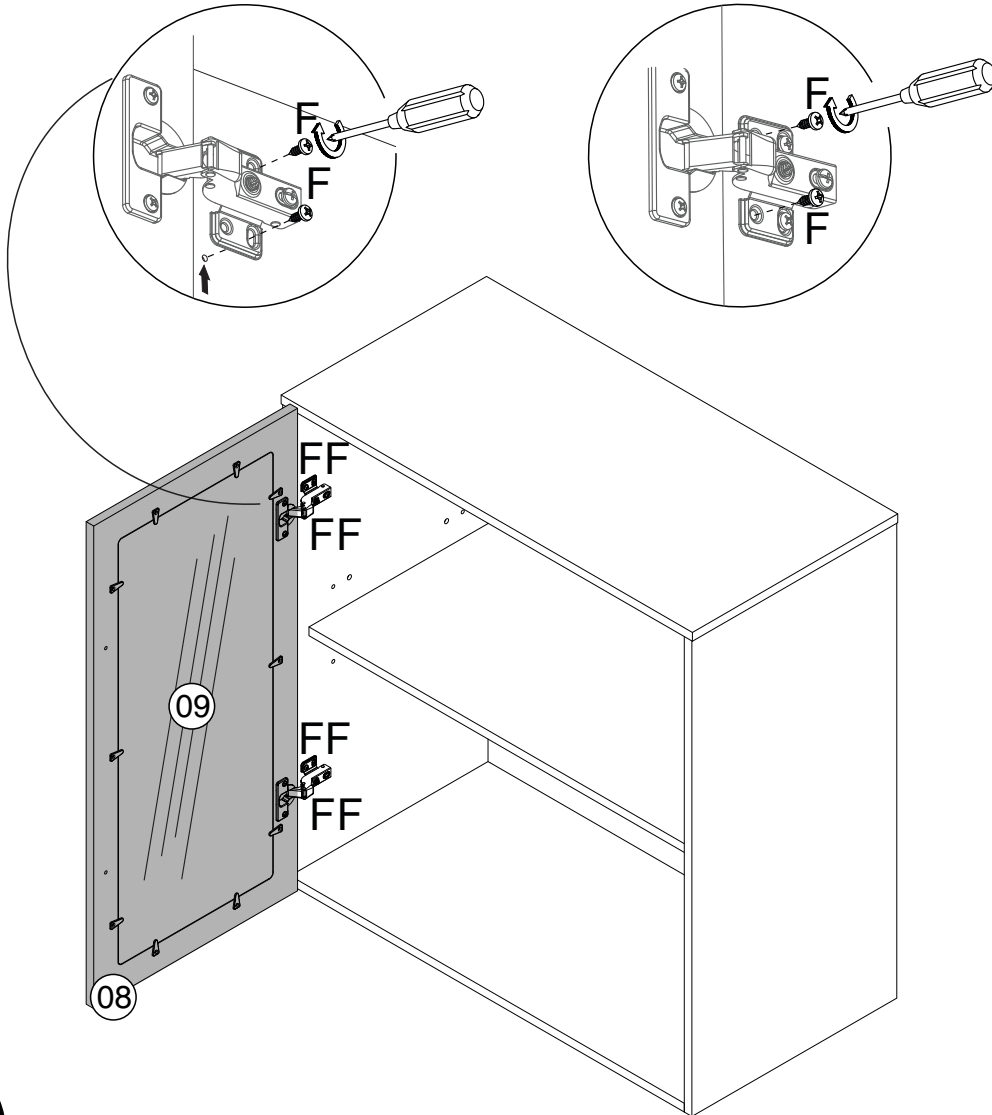

Tip

Adjusting The Cabinet Doors

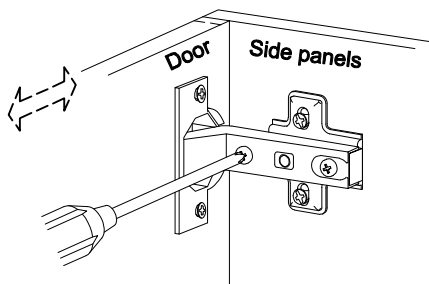

Adjust horizontal width with this screw

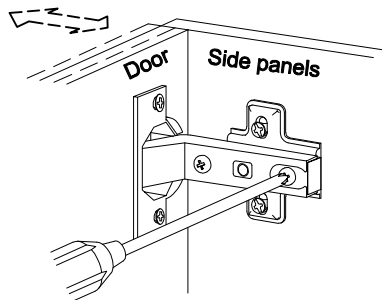

Adjust depth position by loosening the hinge arm mounting screw

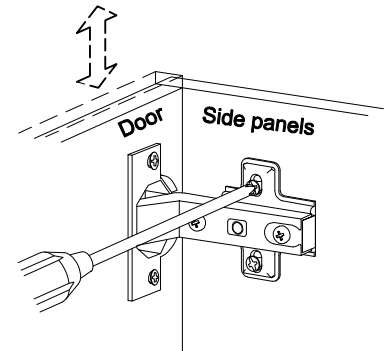

Adjust vertical height via the screws in the mounting plate

Step 10

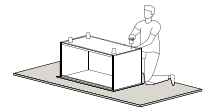

Secure Handle (L) using Screw (E) and a Phillips screwdriver.

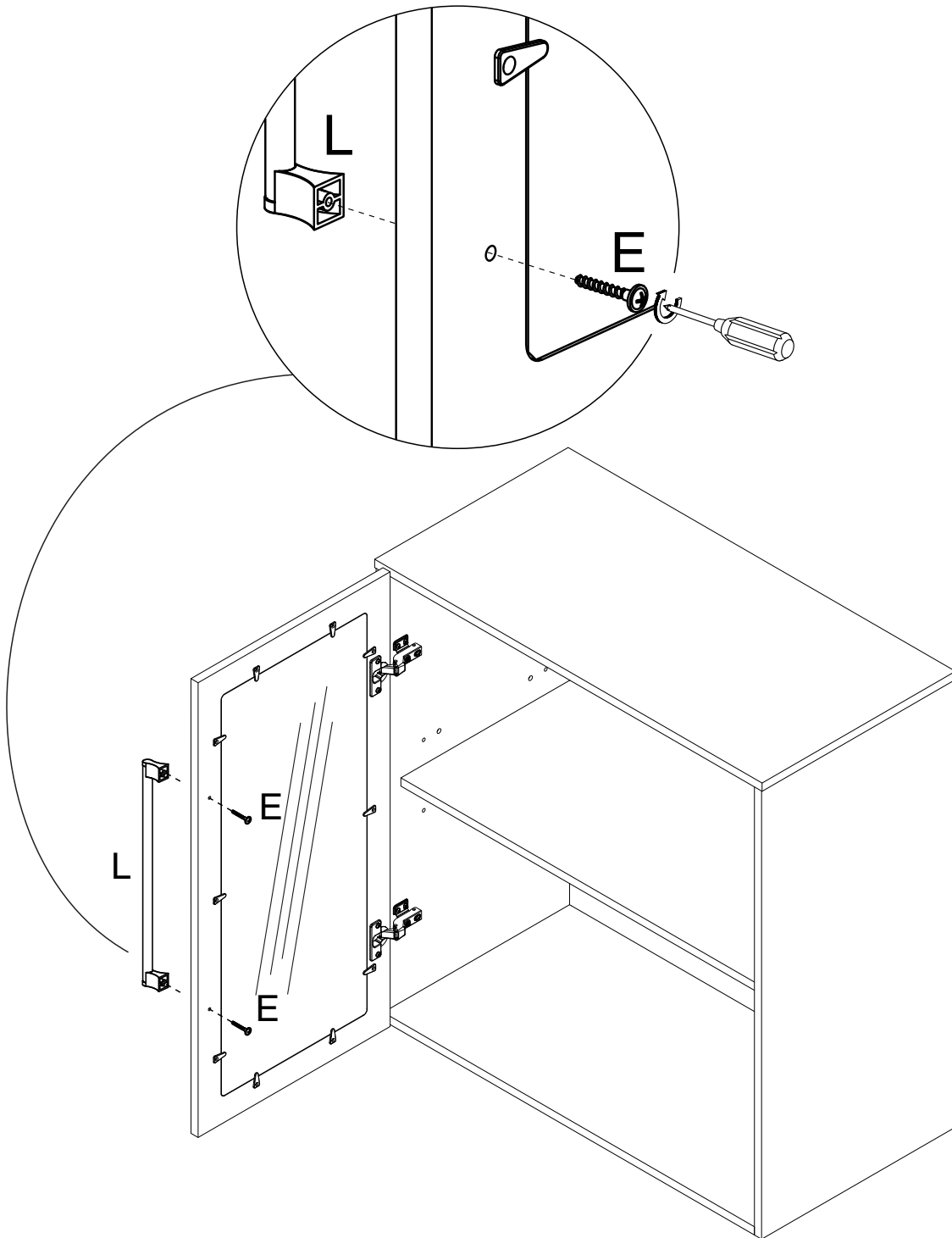

Step 11

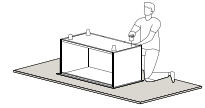

Attach Door (9) on Right Panel (4) using Screws (F) and a Phillips screwdriver.

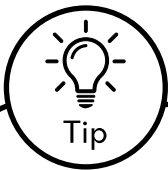
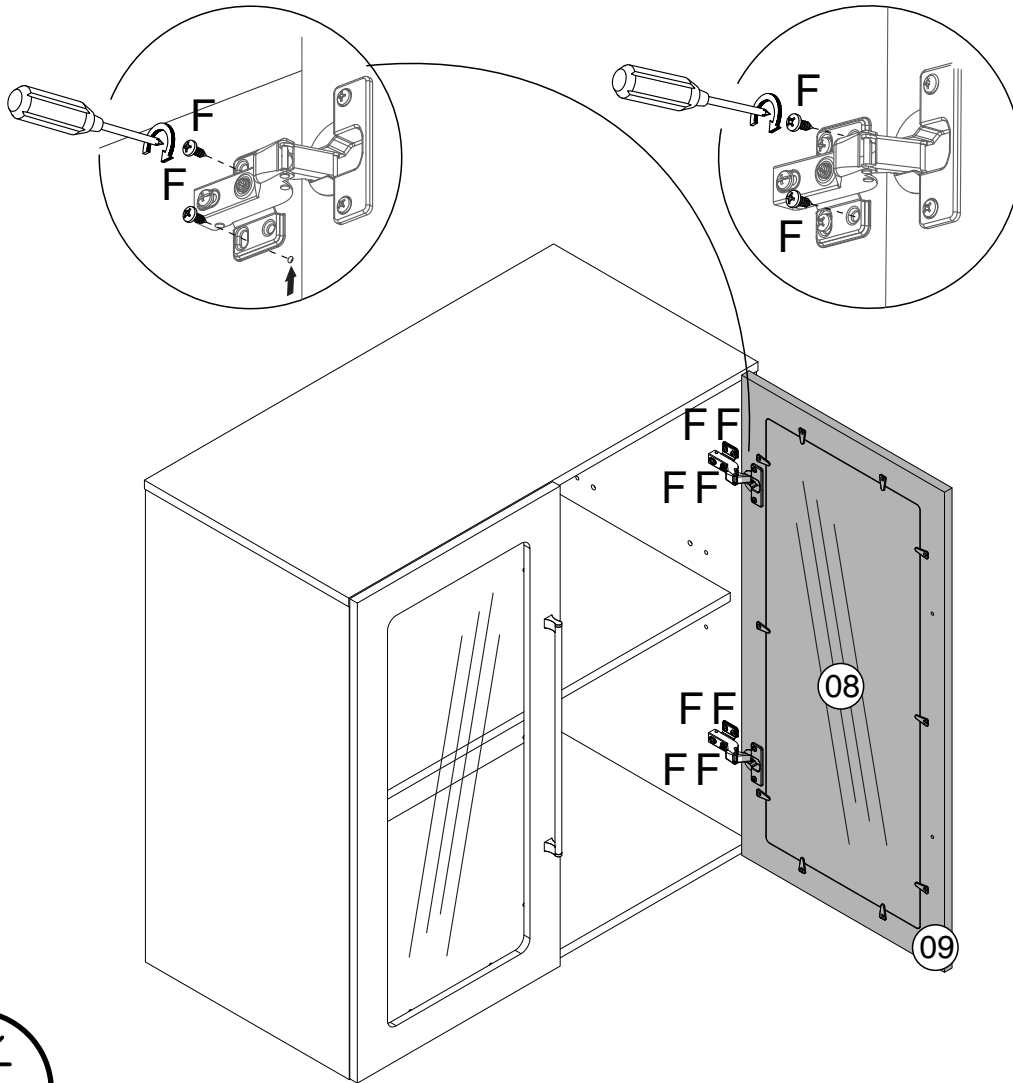

Adjusting The Cabinet Doors

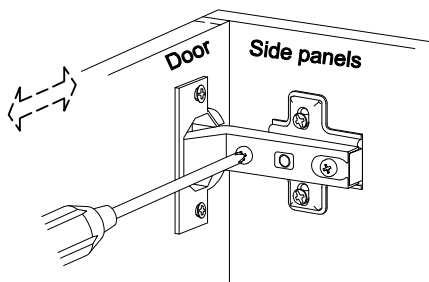

Adjust horizontal width with this screw

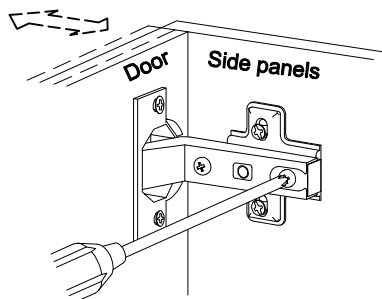

Adjust depth position by loosening the hinge arm mounting screw

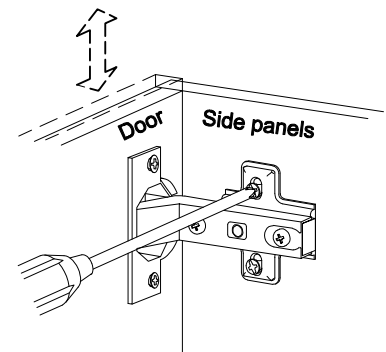

Adjust vertical height via the screws in the mounting plate

Step 12

Secure Handle (L) using Screw (E) and a Phillips screwdriver.

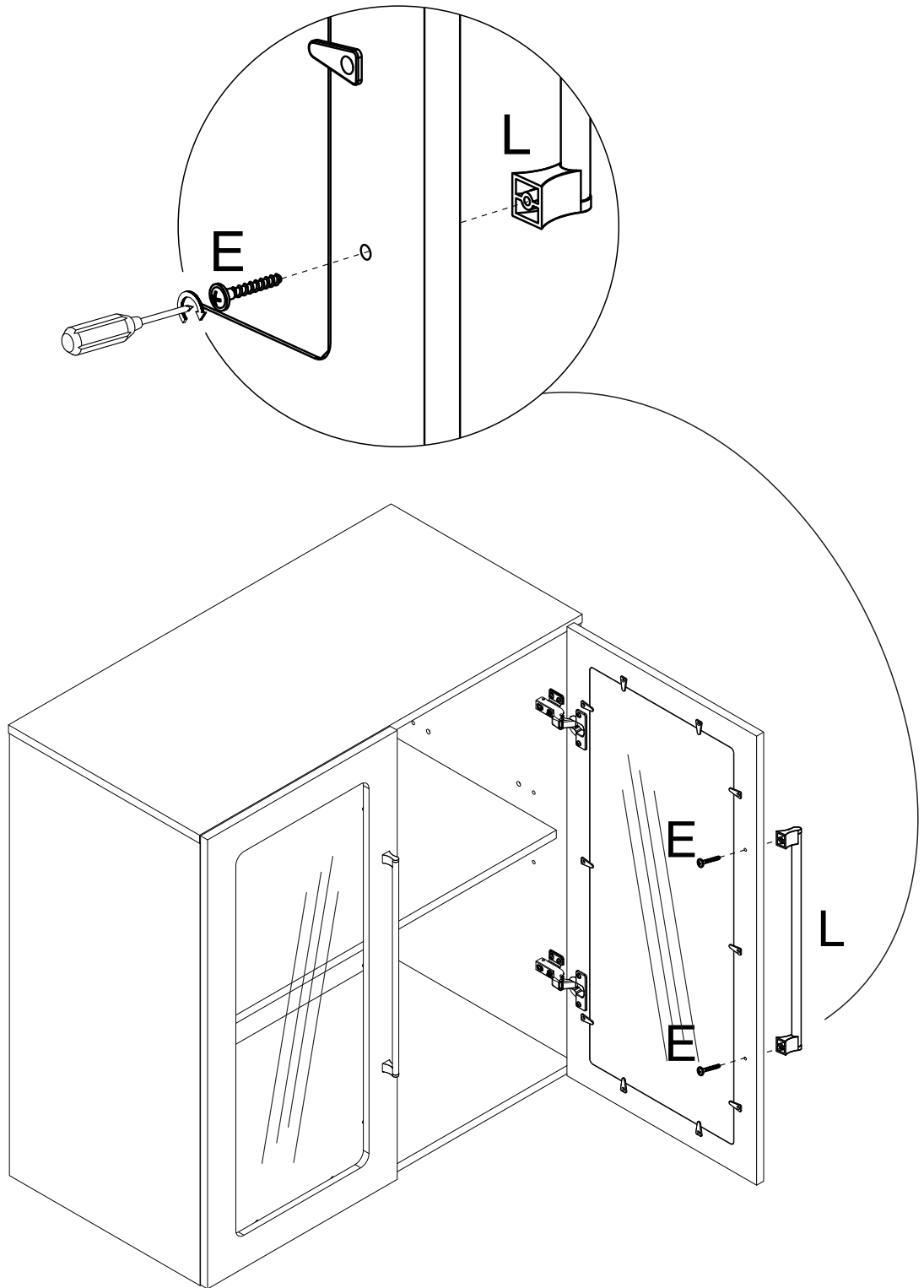

Step 13

Secure Back Panel (6) using Support (K), Screw (I) and a Phillips screwdriver.

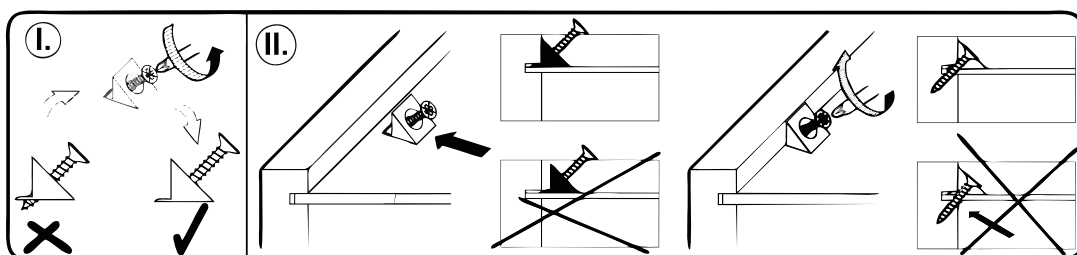
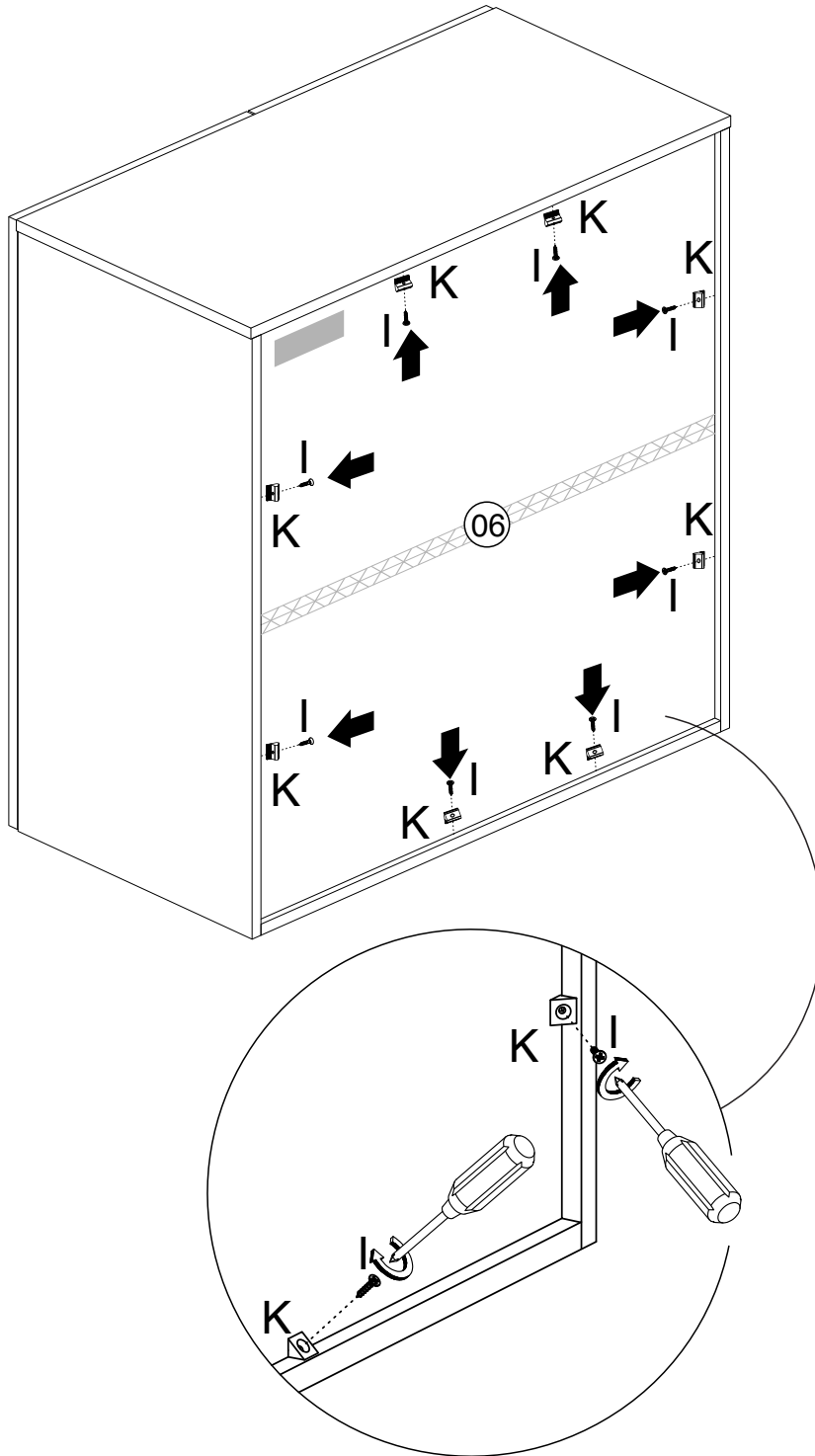

Step 14

If you are not using your new cabinet on top of another Modular Mia Cabinet, you can attach Feet (7) using Screw (H) and a Phillips screwdriver.

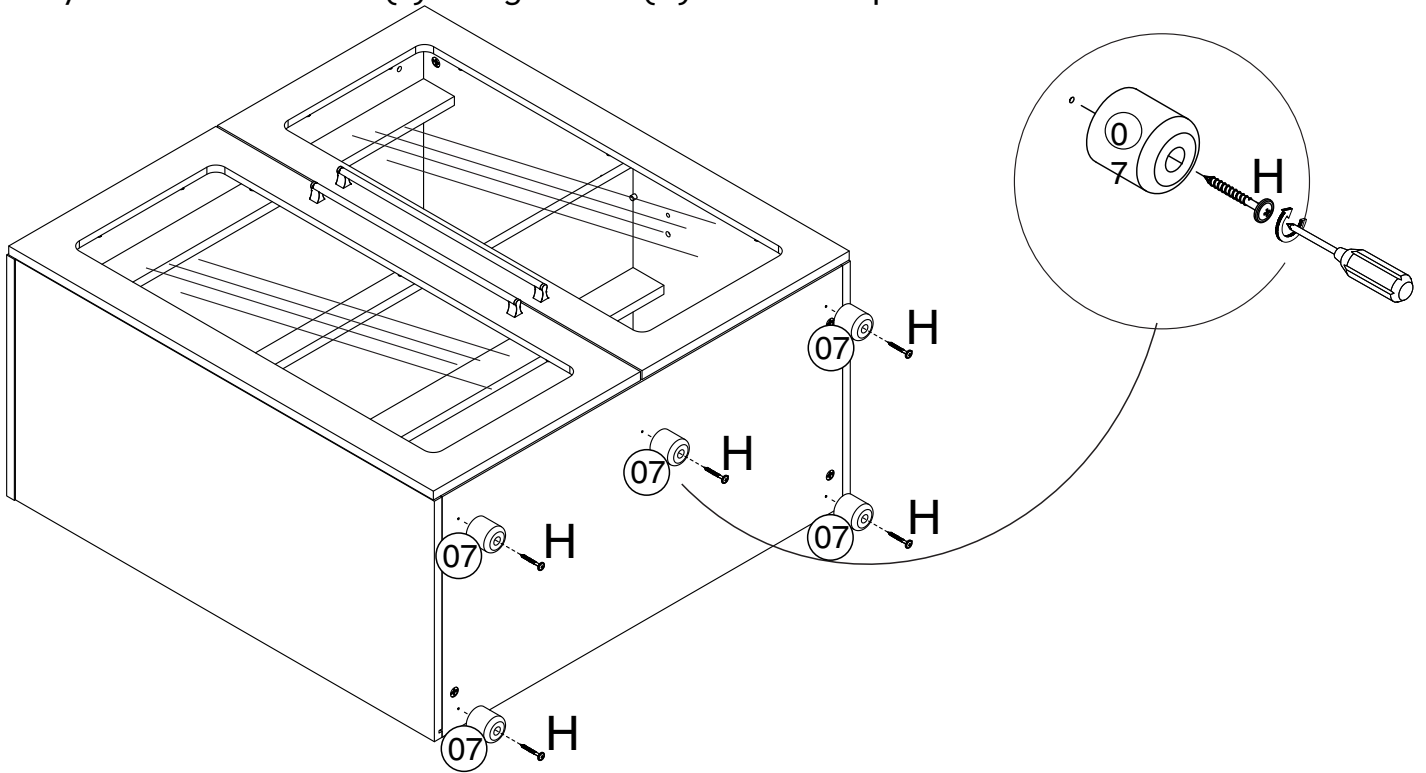

Modular Assembly Options

Step 15

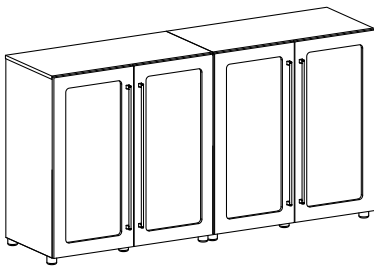

Step 16

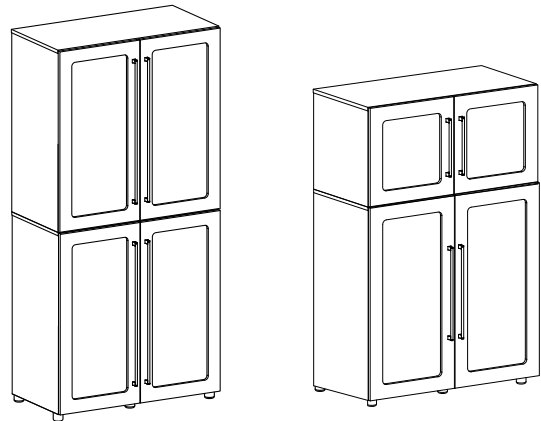

Step 15

Attach your cabinets side by side using Screws (G) and a Phillips screwdriver. The holes as pre drilled.

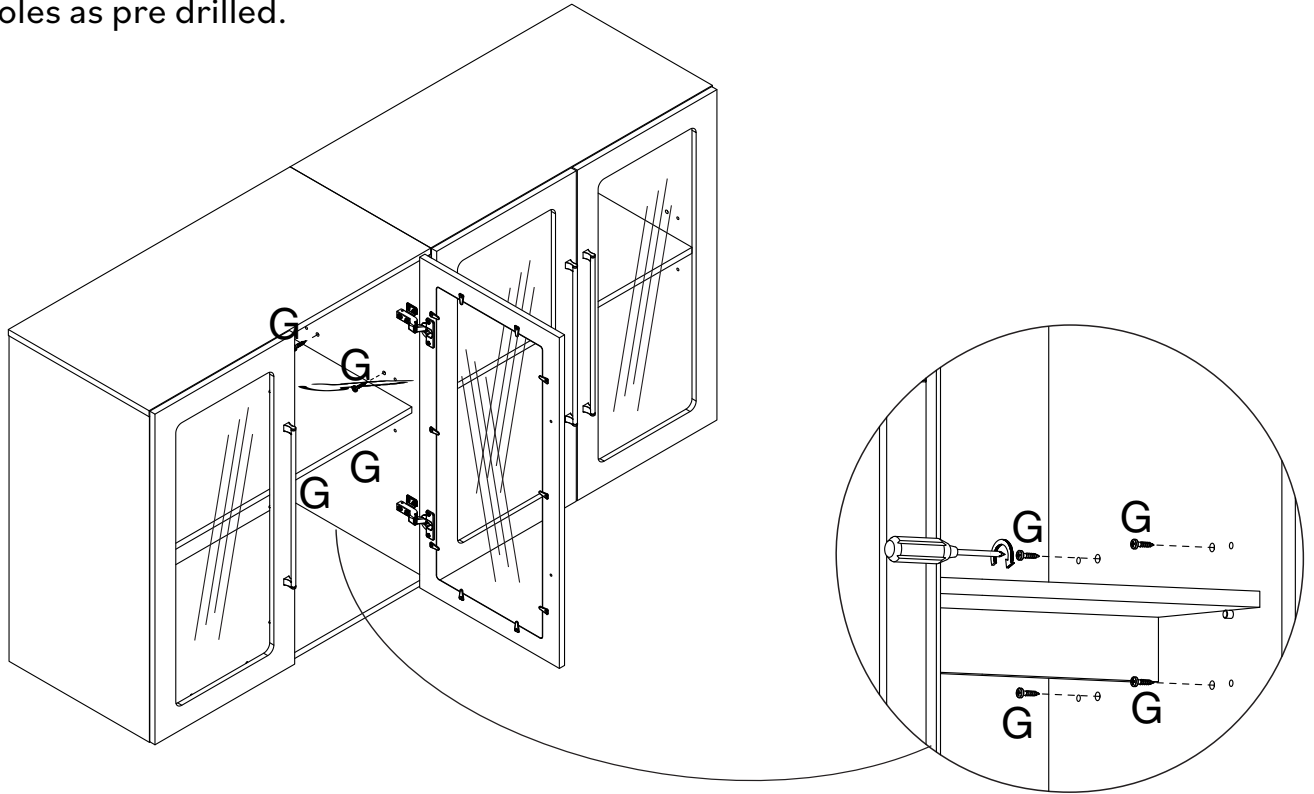

Step 16

If assembling your cabinets on top of each other, use Screws (G) and a Phillips screwdriver to join them through the top and bottom panels. The holes are predrilled

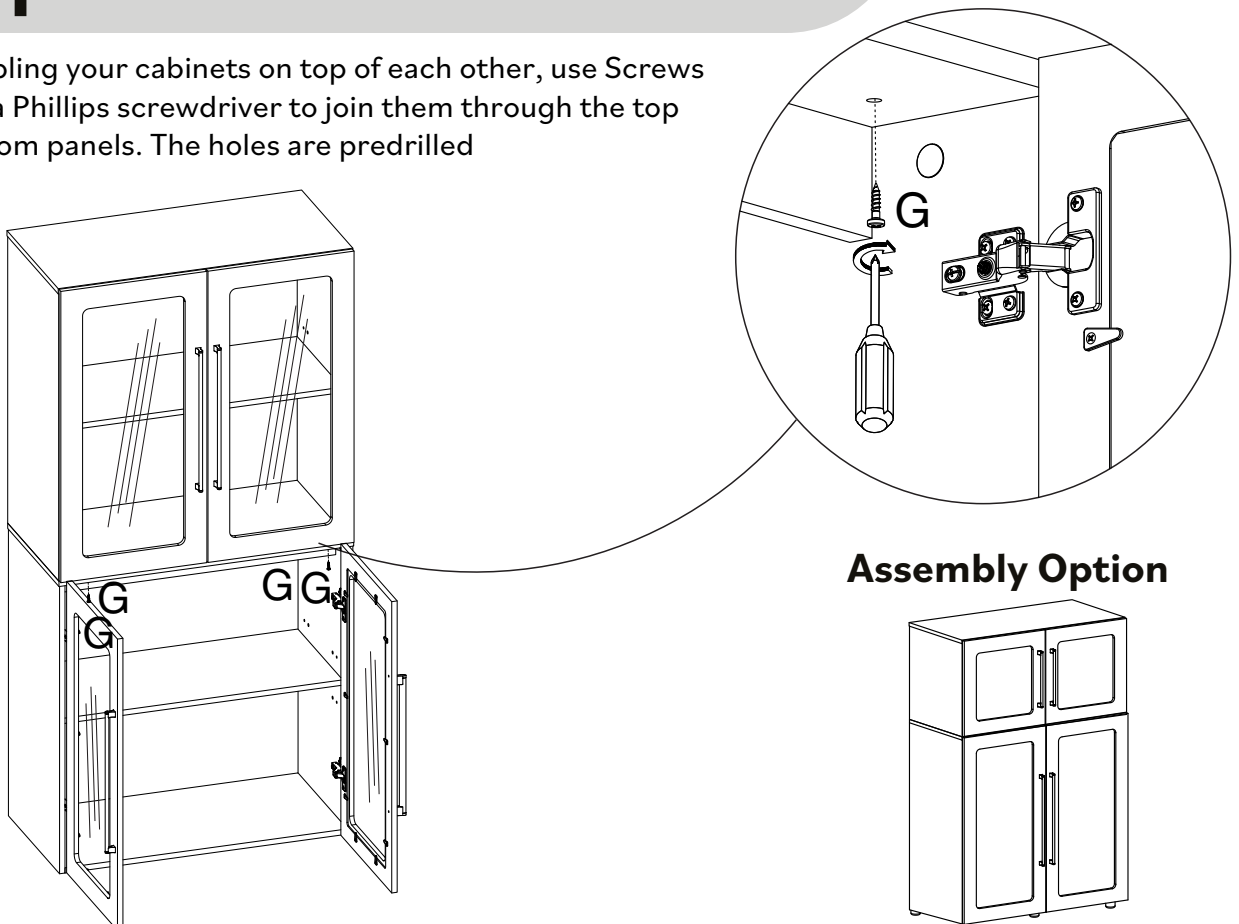

Step 17

With everything in place use Stickers (J) to cover the extra holes.

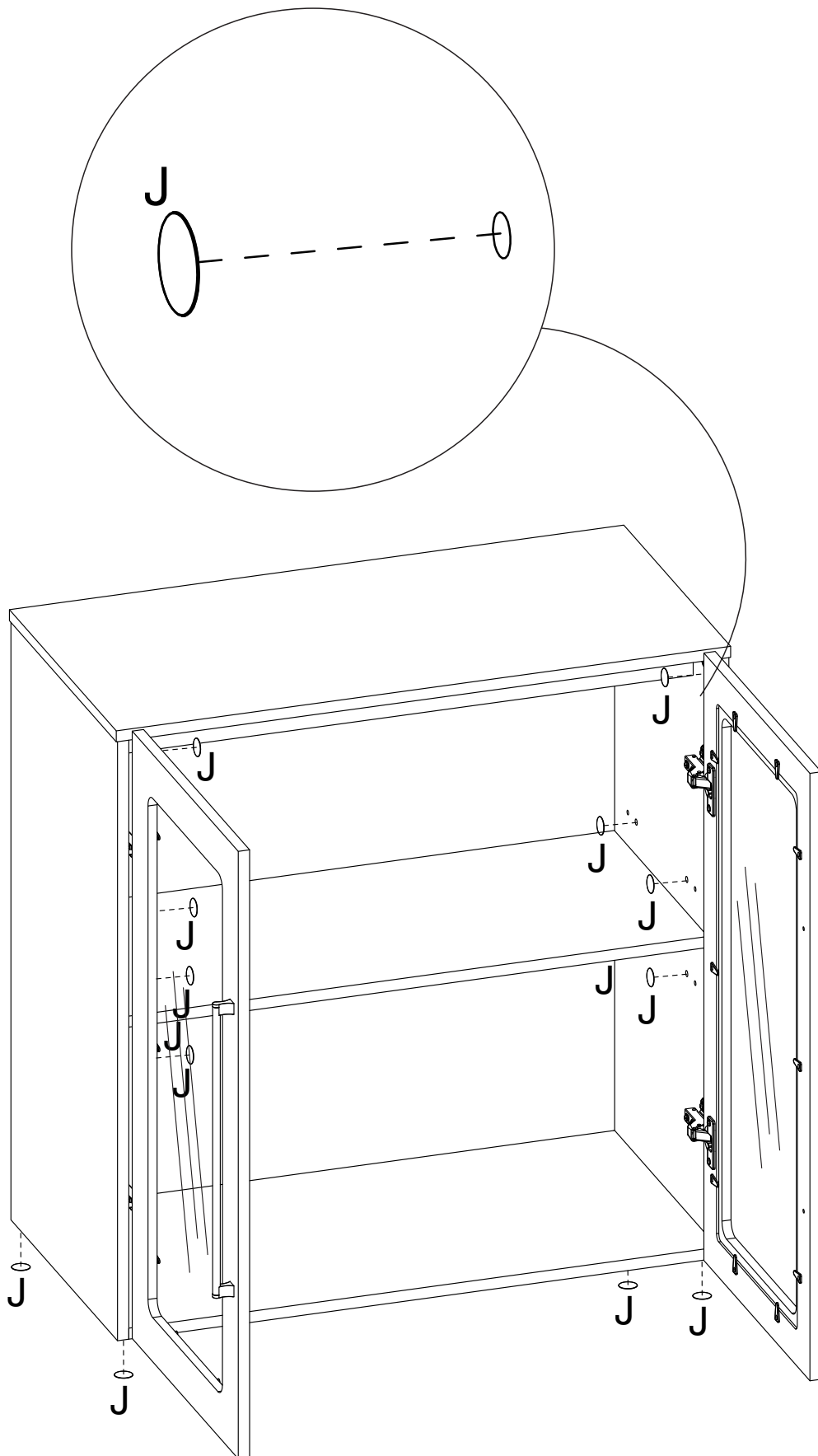

Step 18

Attach your Cabinet to the wall. Secure Wall Anchor (P) to your cabinet using Washer (O), Screw (G) and a Phillips screwdriver.

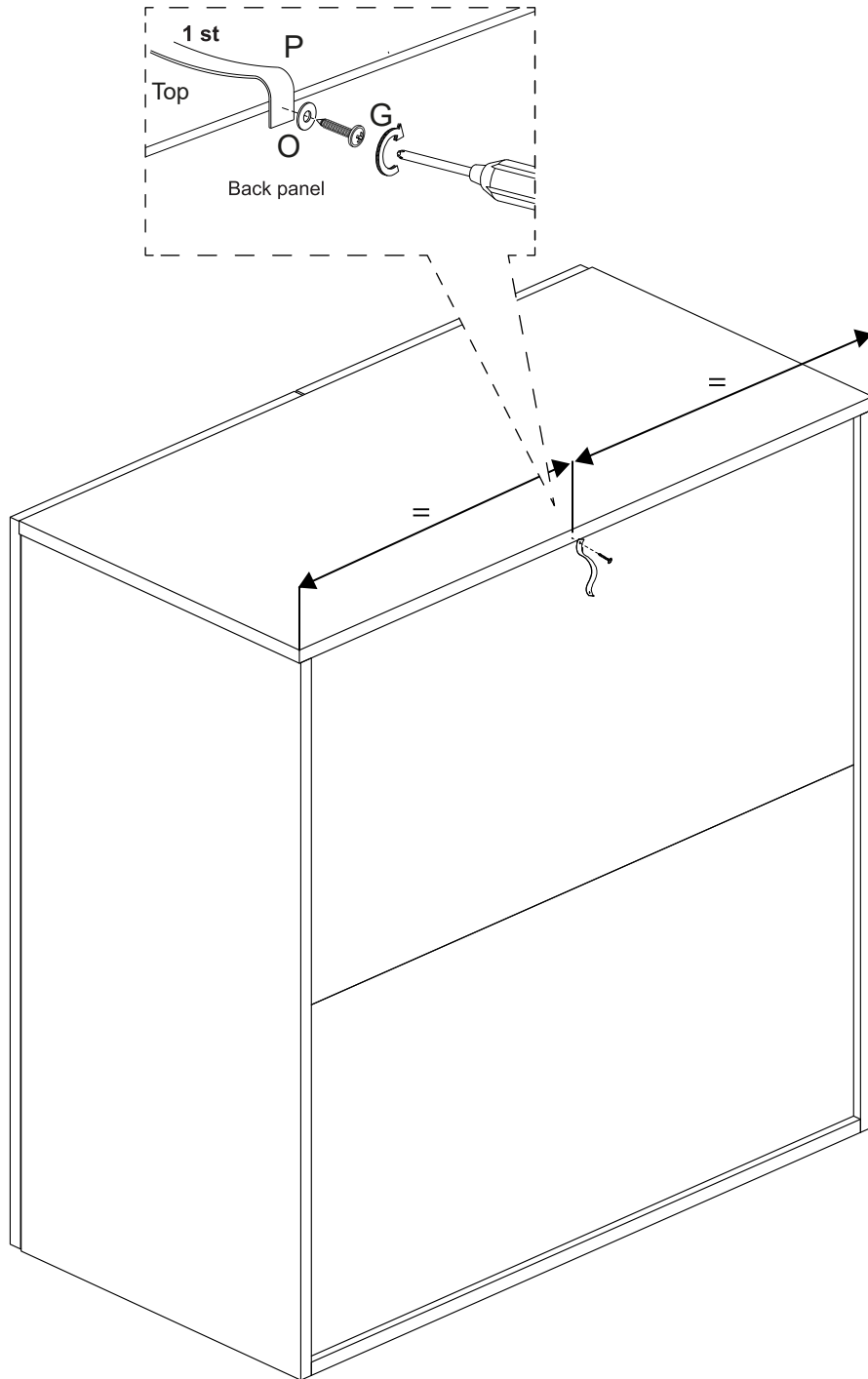

Step 19

To finish this up use a plastic bush suitable for your wall. Then, secure the Wall anchor (P) to the wall using Washer (O) and a screw also suitable for your wall.

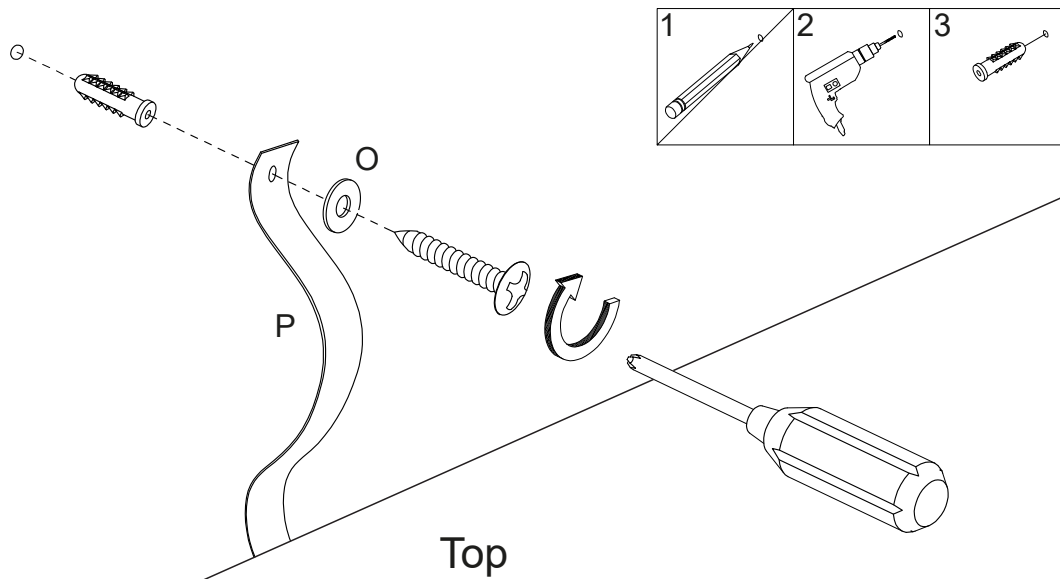

Warning

Serious or fatal injuries can occur from furniture tipping over. To prevent the furniture from tipping over we recommend that it is permanently fixed to the wall. Wall anchor and hardware are included with this product. Please make sure hardware is suitable for your walls before installing, as different wall materials may require different types of anchors.

You did it! Enjoy your new Modular Cabinet!

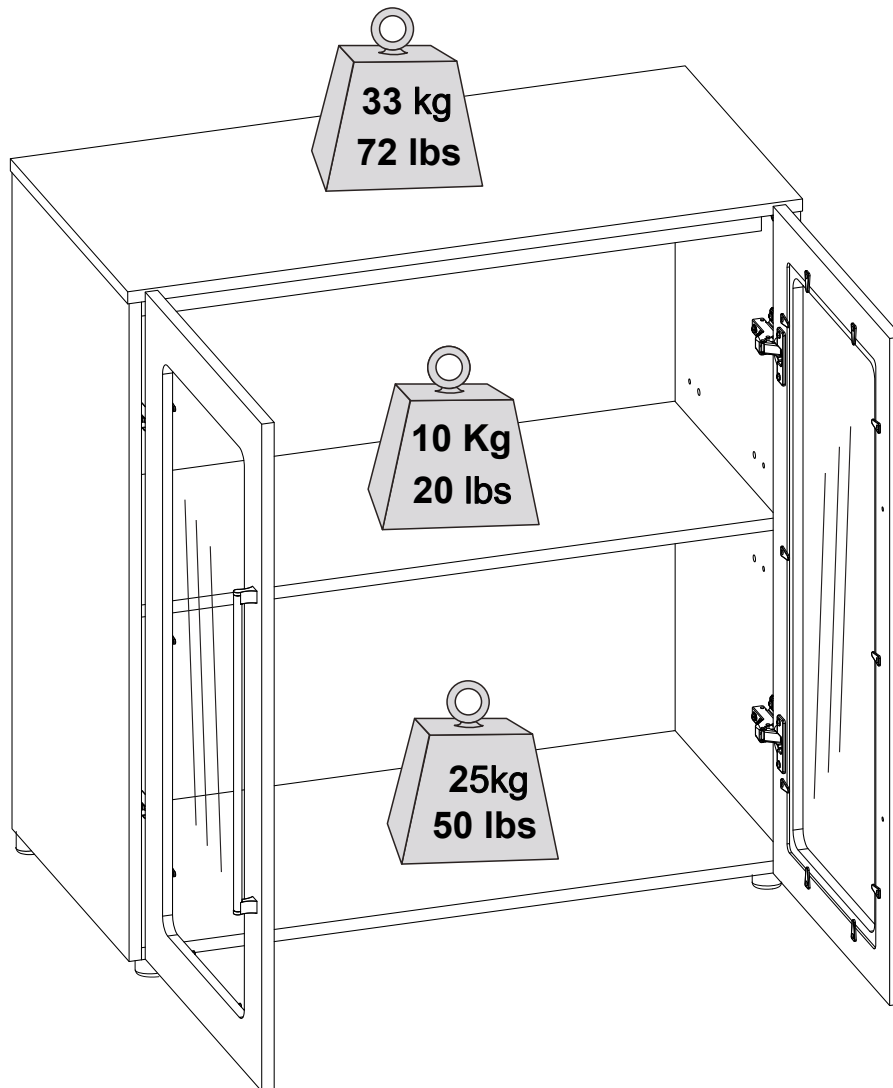

Congratulations on your new piece of furniture!

We would love to hear about it and see it.
Please leave us a review or post a picture with
#mywalkeredisonhome

Assembling furniture can be tricky sometimes.

Our customer service team, located in Utah, is here for product information, help assembling a product, or for any other customer support issue

Call us at **801-433-3008**

Email us at service@walkeredison.com

Visit our Customer Service website at walkeredison.com/pages/customer-service

We are available to help Monday -Thursday 8am-5pm, Friday 8am-3pm MST

For details on Assembly Videos, Assembly Instructions, Replacement Parts, and Customer service,

SCAN HERE

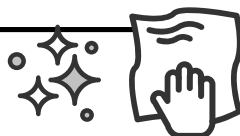

For cleaning, never use abrasives, use a soft cloth and water with neutral soap to clean the furniture.

WALKER EDISON
TM

MIA MODULAR TALL CABINET



Pour usage résidentiel seulement

Visite notre site Web pour obtenir les instructions les plus récentes, des conseils d'assemblage, signaler des dommages ou commander des pièces. www.walkerredison.com

Sólo para uso residencial

Visite nuestro sitio web para consultar las últimas instrucciones, consejos de montaje, notificar daños o solicitar piezas. www.walkerredison.com

WE Il est temps de commencer / Hora de empezar

Prépare un lieu de travail propre et souple pour éviter tout dommage lors de l'assemblage. Tu peux utiliser la boîte et les protections internes comme base. Vérifie également que tu disposes de toutes les pièces et parties avant de te lancer dans l'assemblage.

Prepare un lugar de trabajo limpio y blando para evitar daños durante el montaje. Puede utilizar la caja y las protecciones internas como base. Comprueba también que tiene todas las piezas y partes antes de sumergirse en el montaje.

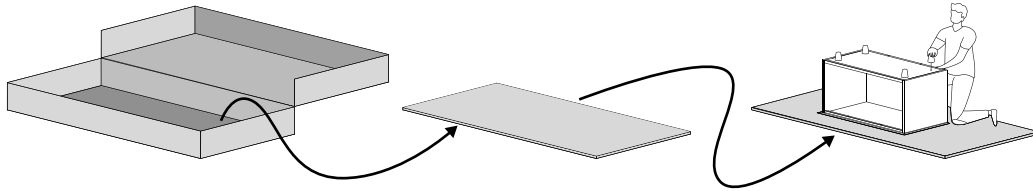

**Temps de montage
estimé**

**Tiempo estimado
de montaje**

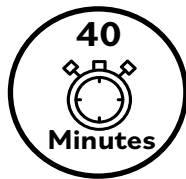

2 Personnes
2 Personas

**Personnes recommandées
pour le montage**

Fais-en un effort d'équipe !
Appelle un ami pour un assemblage
plus rapide et plus facile.

**Personas recomendadas
para el montaje**

¡Hágalo en equipo!
Llame a un amigo para que el
montaje sea más rápido y sencillo.

Outils nécessaires

Munis-toi d'un tournevis cruciforme pour réaliser cet assemblage.

Herramientas requeridas

Tome un destornillador Phillips pour conquister este montaje.



Utilise les outils électriques avec précaution

Ce meuble est réalisé en Bois Massif et Bois Composite, des matériaux souples. Si tu choisis d'utiliser des outils électriques, règle-les sur le mode le plus lent. Fais attention à toi ! Les outils électriques peuvent provoquer des fissures ou endommager les meubles, mais aussi les autres composants s'ils sont mal utilisés. Les dommages causés par un outil électrique ne sont pas couverts par la garantie Walker Edison.

Utilice las herramientas eléctricas con cuidado.

Este mueble está fabricado con madera maciza y madera compuesta, materiales blandos. Si decide utilizar herramientas eléctricas, ajústelas al ajuste más lento. Tenga cuidado. Las herramientas eléctricas pueden causar grietas o daños en el mueble, pero también en los herrajes si se utilizan mal. Los daños causados por una herramienta eléctrica no están cubiertos por la garantía de Walker Edison.

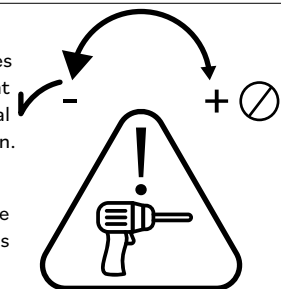

**Scannez pour obtenir des conseils d'assemblage et de l'aide !
¡Escanee para obtener consejos de montaje y ayuda!**



Parts List

Part Number	Description	Quantity
01	Panneau Inférieur Panel Inferior	1
02	Panneau Gauche Panel Izquierdo	1
03	Panneau Supérieur Panel Superior	1
04	Panneau Droit Panel Derecho	1
05	Étagere Estante	2
06	Panneau Arrière Panel Trasero	1
07	Pied Pie	5
08	Porte Puerta	2
09	Façade de Porte en Verre Frente de la Puerta en Vidrio	2
10	Barre Supérieur Travesaño Superior	1
11	Barre de Étagere Travesaño de la Estante	1

WALKER EDISON

Distribution and responsible for the anti-tip hardware:
Walker Edison Furniture Company
1553 W 9000 S, West Jordan,
UT 84088 United States

For details on Assembly Videos, Assembly Instructions,
Replacement Parts and Customer Service, SCAN HERE.







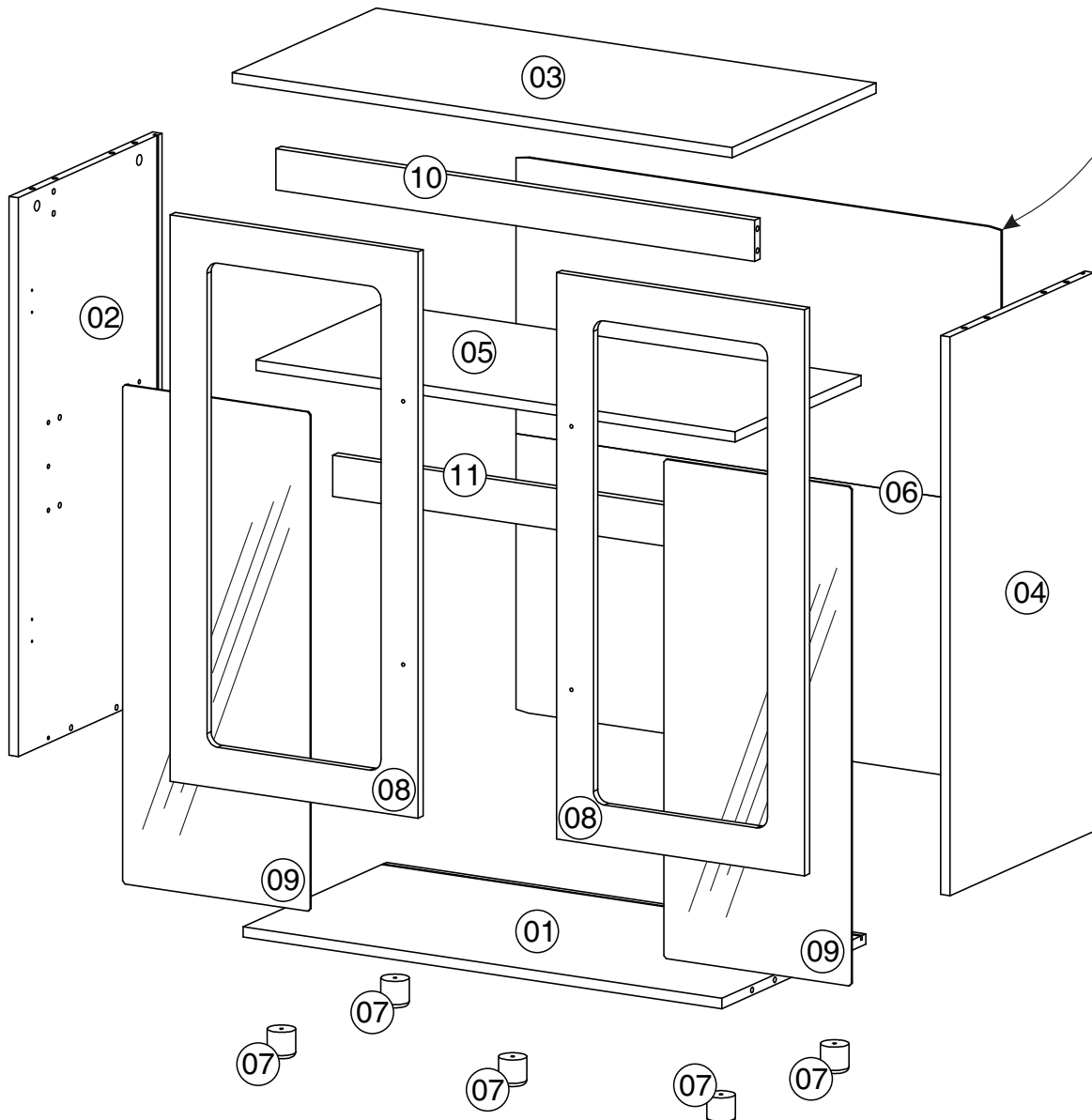

Collection Name

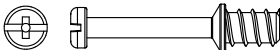
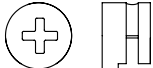

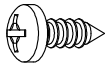
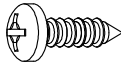
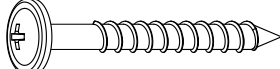
Model: XXXXXXXXFF
LOT: AAYYWW-XXX
Date: MM/20YY
Rev. MM/20YY-VX

CANFER compliant / conforme au CANFER
TSCA Title VI compliant / conforme au titre VI de la TSCA
TSCA Title VI certified / certifié conformément au titre VI de la TSCA
California 93120 Compliant for Formaldehyde /
Conforme à la norme Californie 93120 pour le formaldéhyde.

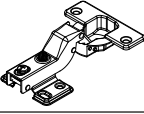

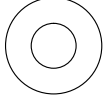
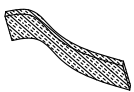
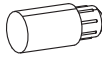
Partie Parte	Taille Tamaño	Nom Nombre	Quantité Cantidad
A 	8x30mm	Cheville Espiga	14
B 	Ø7x30mm	Goujon Conector	11
C 	Ø15x10mm	Boitier Traba	11
D 	Ø3,5x12mm	Vis Tornillo	20
E 	Ø3,5x25mm	Vis Tornillo	4
F 	Ø4x14mm	Vis Tornillo	24
G 	Ø4x20mm	Vis Tornillo	5
H 	Ø5x40mm	Vis Tornillo	5
I 	Ø3x16mm	Vis Tornillo	8
J 	Ø 19mm	Autocollants Pegatinas	19
K 	14,7x30mm	Support Soporte	8
L 	224mm	Poignée Manija	2
M 	Ø35mm	Charnières Bisagras	4
N 	25x12mm	Support de porte Soporte de la puerta	20
O 	1/4x5/8	Rondelle Arandela	02
P 	20x200mm	Rubán Cinta	01
Q 	6x18mm	Support de étagère Soporte de estante	04

*Les quantités de composants indiquées ci-dessus sont nécessaires pour un assemblage correct.
Des pièces supplémentaires peuvent être incluses.*

*Las cantidades de tornillería indicadas anteriormente son necesarias para un montaje correcto.
Se pueden incluir piezas de ferretería adicionales.*

Étape / Paso 1

(FR)

C'est parti ! Insérez les chevilles en bois (A) dans le panneau inférieur (1), le panneau gauche (2), le panneau droit (4), le rail supérieur (10) et le rail d'étagère (11). Fixez également les boulons à came (B) au panneau gauche (2), au panneau supérieur (3) et au panneau droit (4) à l'aide d'un tournevis cruciforme.

(ES)

¡Comencemos! Inserte las clavijas de madera (A) en el panel inferior (1), el panel izquierdo (2), el panel derecho (4), el riel superior (10) y el riel del estante (11). Además, fije los pernos de leva (B) al panel izquierdo (2), el panel superior (3) y el panel derecho (4) con un destornillador Phillips.

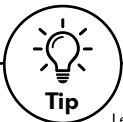
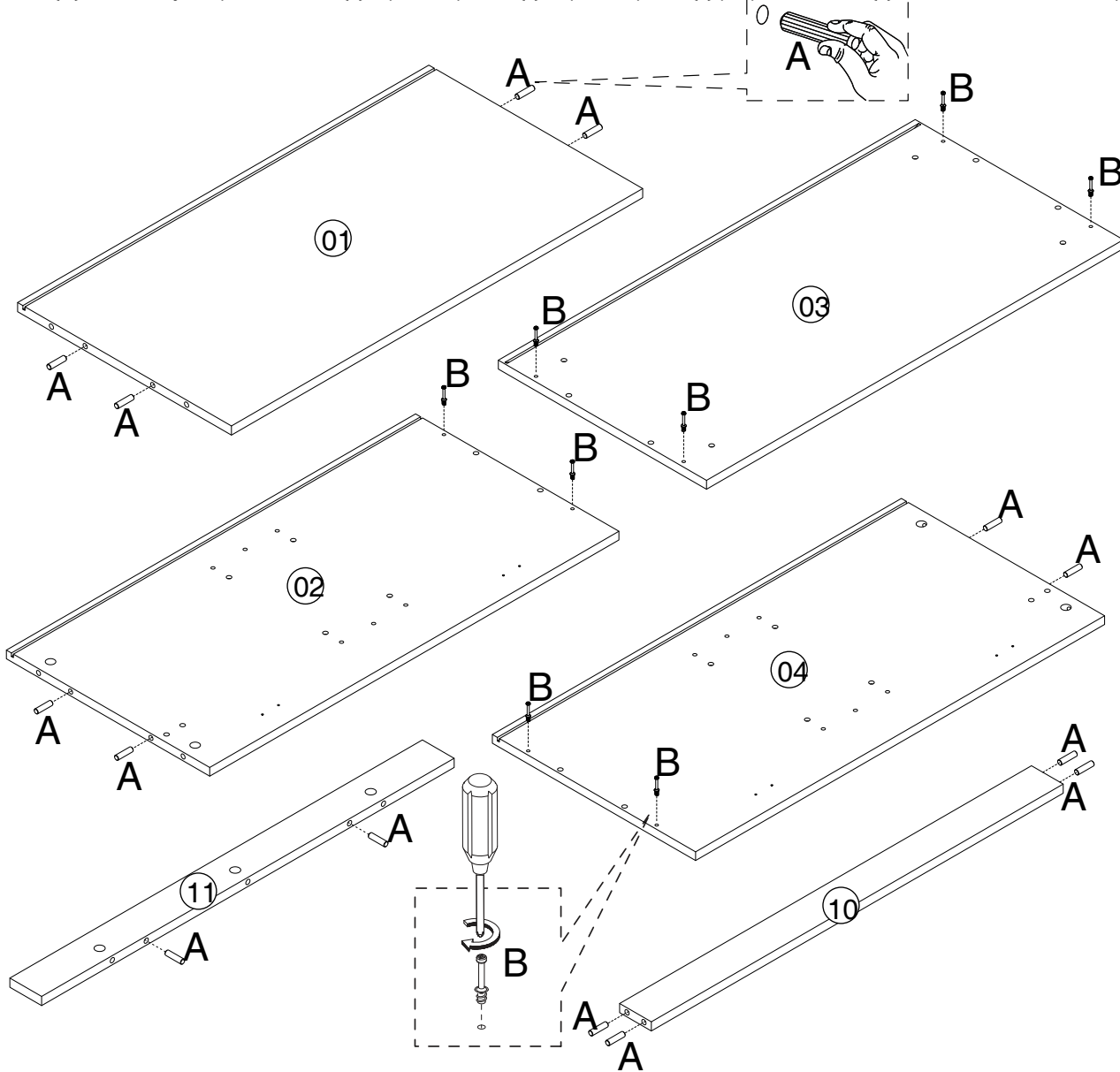

Cheville en bois

Les chevilles sont essentielles lors de l'assemblage de meubles pour créer des connexions solides et précises. Elles garantissent l'intégrité structurelle, empêchent les déplacements et simplifient l'alignement, ce qui permet d'obtenir des meubles plus résistants et plus durables. suis ces étapes :

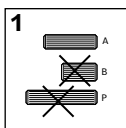

1: Sélectionne la taille de cheville appropriée en fonction de l'étape.
1: Seleccione el tamaño de espiga adecuado según el paso.

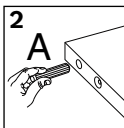

2: Insère dans le trou indiqué et appuie fermement pour assurer un positionnement correct.
2: Insértela en el orificio indicado y presione firmemente para asegurar su correcta colocación.

Espiga de madera

Las espigas son esenciales en el montaje de muebles para crear uniones fuertes y precisas.

Garantizan la integridad estructural, evitan el desplazamiento y simplifican la alineación, lo que se traduce en muebles más resistentes y duraderos.

Sigue estos pasos:

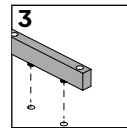

3: Alinee la cheville avec la pièce correspondante et enfonce-la jusqu'à ce qu'elle soit ferme.
3: Alinee el pasador con la pieza correspondiente y presiónelo hasta que encaje.

Étape / Paso 2

(FR)

Fixez les charnières (M) aux portes (8) à l'aide de la vis (F) et d'un tournevis cruciforme. Insérez la façade de porte en verre (9) dans les portes (8) et fixez-la à l'aide du support de porte (N), de la vis (D) et d'un tournevis cruciforme.

(ES)

Fije las bisagras (M) a las puertas (8) con el tornillo (F) y un destornillador Phillips. Inserte el frente de la puerta en vidrio (9) en las puertas (8) y fíjelo con el soporte de la puerta (N), el tornillo (D) y un destornillador Phillips.

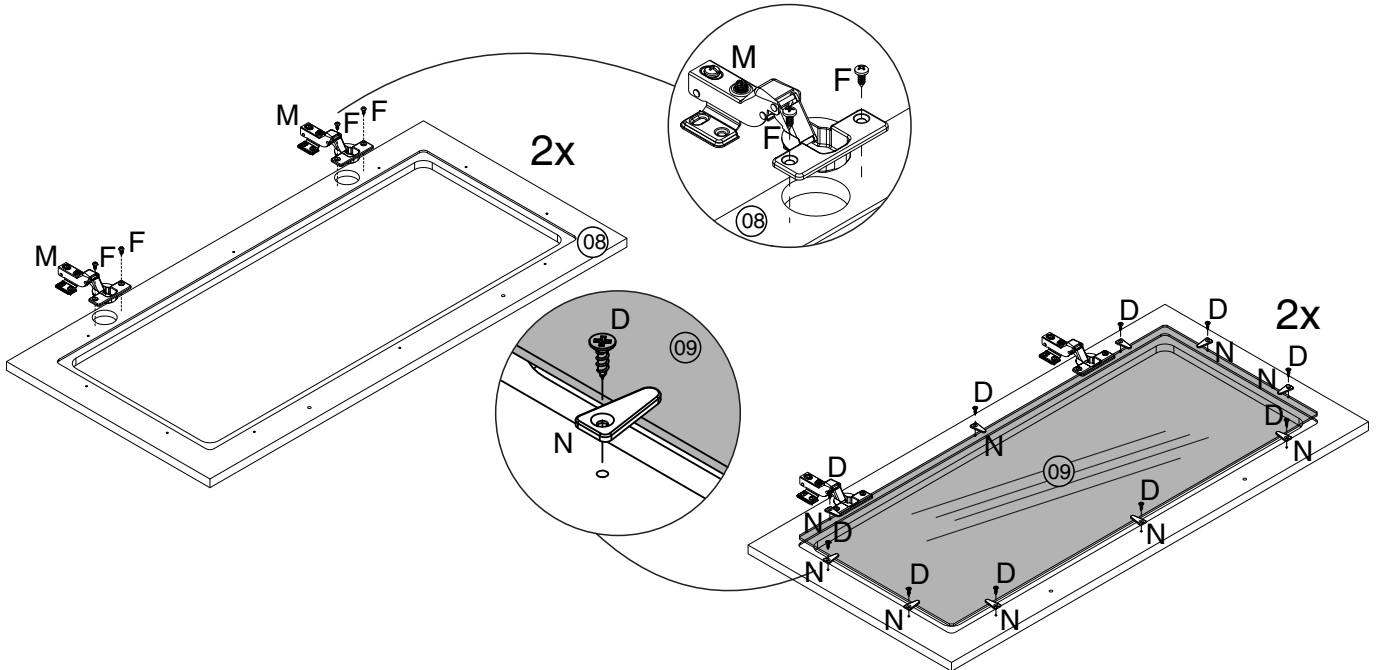

Étape / Paso 3

(FR)

Joignez le panneau inférieur (1) et le panneau gauche (2) à l'aide de verrous à came (C) et d'un tournevis cruciforme.

(ES)

Una el panel inferior (1) y el panel izquierdo (2) usando cerraduras de leva (C) y un destornillador Phillips.

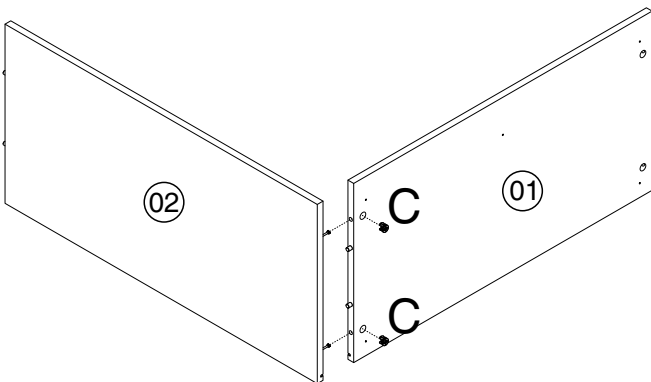

Tip

Pour que ton produit conserve son meilleur aspect et sans rayures, essaie de le monter sur une surface souple telle qu'un tapis ou une couverture. Cela permet d'éviter les rayures accidentelles et de garder tes meubles en bon état!

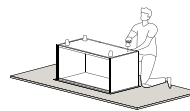

Para mantener su producto con el mejor aspecto y sin arañazos, pruebe a montarlo sobre una superficie blanda, como una alfombra o una manta. Así evitará arañazos accidentales y mantendrá sus muebles en perfecto estado.



Tip

Goujon de Assemblage

Goujon de Assemblage permet de joindre deux pièces en toute sécurité. Suis ces étapes simples.

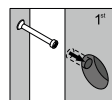

1: Insère le Goujon dans les orifices du côté plat. Ne serre pas trop!

1: Coloca el Conector en los orificios del lado plano. ¡No aprietes demasiado!

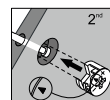

2: Joins les pièces en bois. Les Goujons entrent dans les orifices qui ont des trous sur les côtés, tu dois pouvoir voir les Goujons à travers ceux-ci. Après avoir installé les pièces, insère le Boitiers dans les orifices latéraux

2: Una las piezas de madera. Los Conectores entran en las piezas que tienen orificios en los lados, por lo que deberías poder ver los Conectores a través de ellos. Después de encajar las piezas, inserta la traba en los orificios laterales.

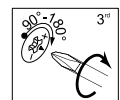

3: Sur la partie arrière du boîtier, il aura la forme d'un « C ». Insère le boîtier de manière à ce que l'ouverture « C » s'emboîte à la goujon. Serre-la avec le tournevis.

3: La parte posterior de la traba tendrá la forma de "C". Inserta el tambor de modo que la abertura de la "C" encaje en el Conector. Apriétalo con un destornillador.

Conector

Los Conector ayudan a unir de forma segura dos piezas. Sigue estas fáciles etapas.

Étape / Paso 4

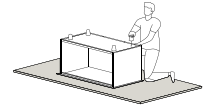

(FR)

Fixez le barre supérieur (10) et le panneau droit (4) à l'aide de chevilles, de verrous à came (C) et d'un tournevis cruciforme.

(ES)

Asegure el travessaño superior (10) y el panel derecho (4) usando clavijas, cerraduras de leva (C) y un destornillador Phillips.

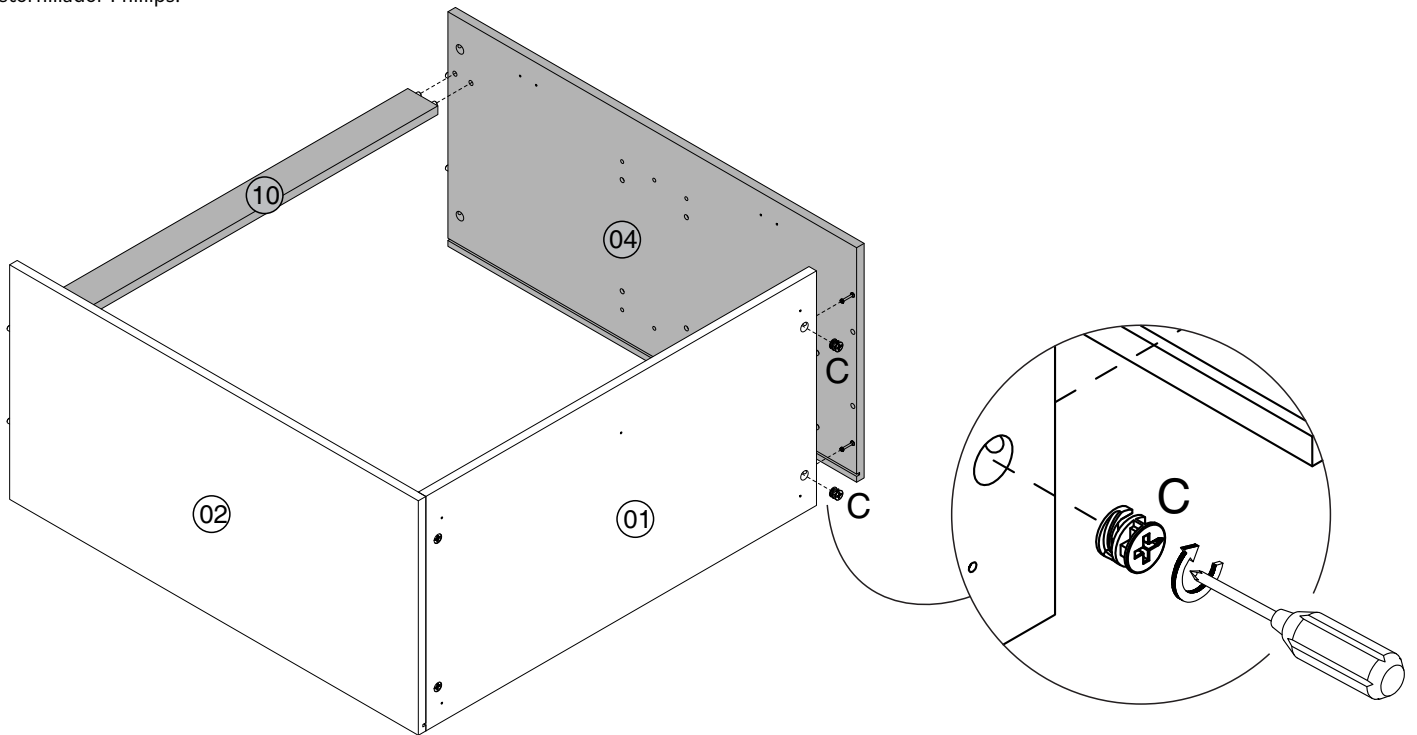

Étape / Paso 5

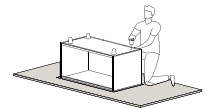

(FR)

Faites glisser le panneau arrière (6) entre les rainures du panneau gauche (2) et du panneau droit (4) en l'insérant dans le panneau inférieur (1).

(ES)

Deslice el panel posterior (6) entre las ranuras del panel izquierdo (2) y el panel derecho (4) encajando en el panel inferior (1).

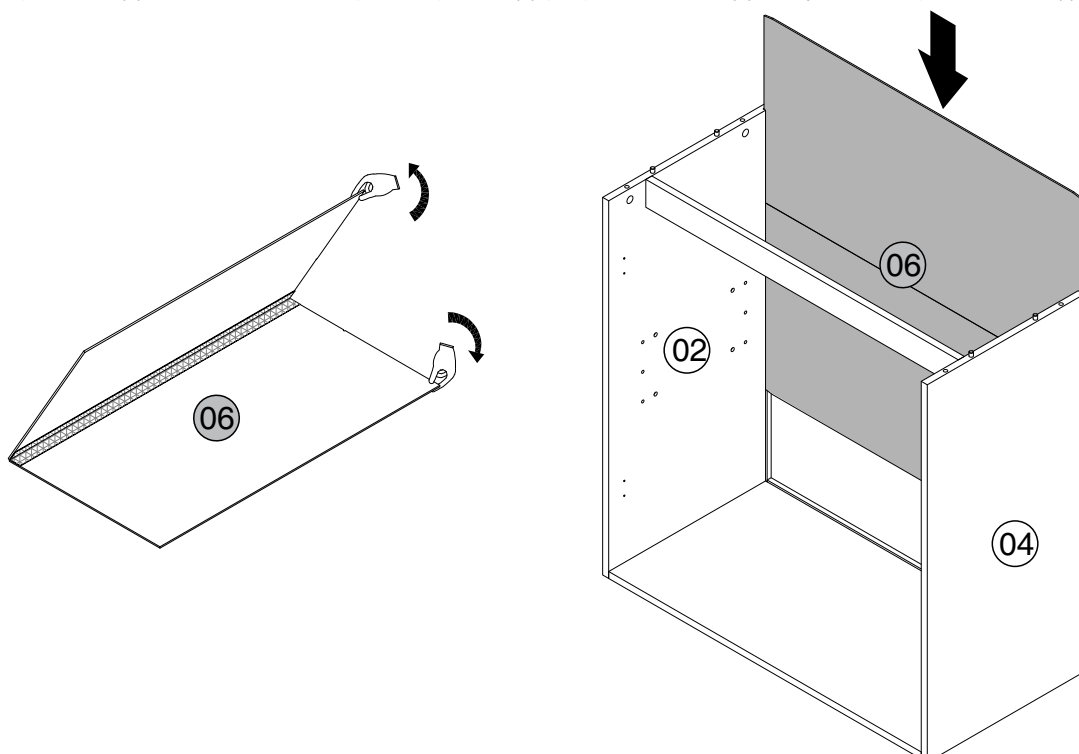

Étape / Paso 6

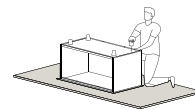

(FR) Fixez le panneau supérieur (3) au panneau gauche (2) et au panneau droit (4) à l'aide des verrous à came (C) et d'un tournevis cruciforme.
(ES) Conecte el panel superior (3) al panel izquierdo (2) y al panel derecho (4) usando cerraduras de leva (C) y un destornillador Phillips.

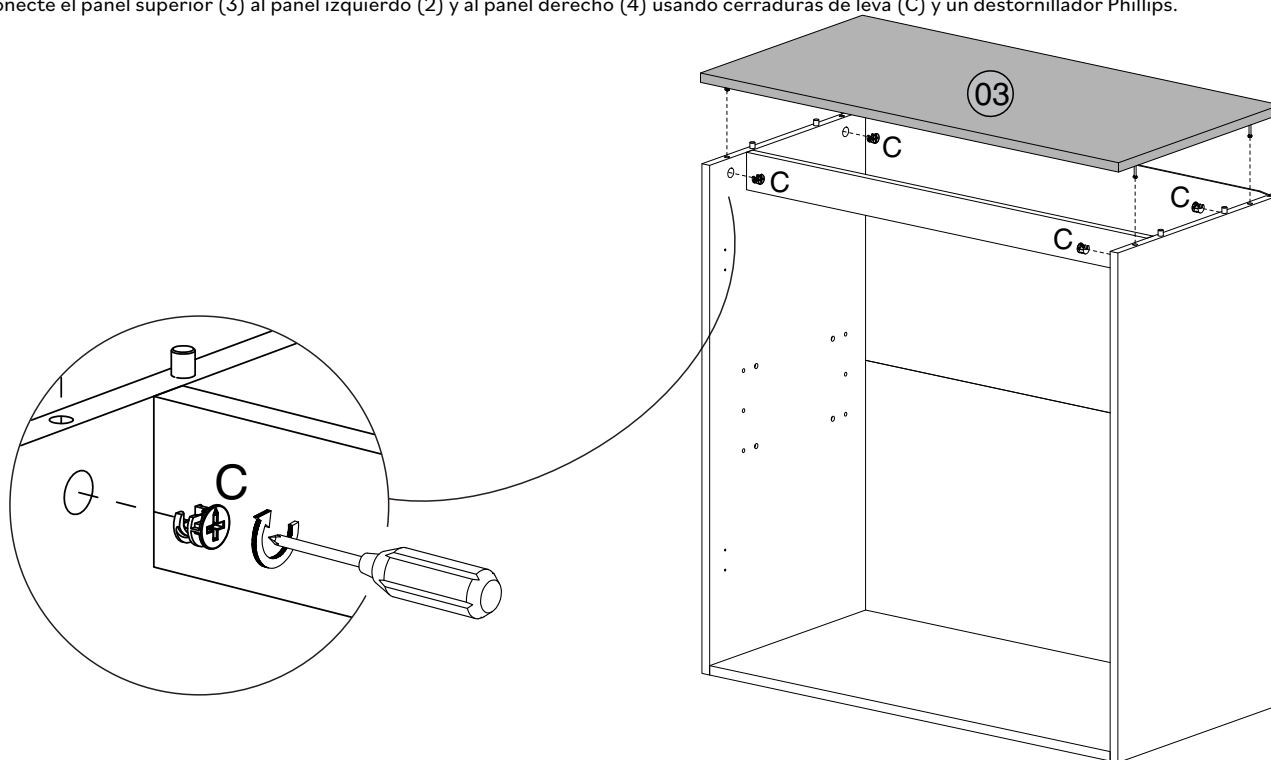

Étape / Paso 7

(FR) Fixez le rail d'étagère (11) à l'étagère (5) à l'aide des verrous à came (C) et d'un tournevis cruciforme.
(ES) Asegure el riel del estante (11) al estante (5) usando cerraduras de leva (C) y un destornillador Phillips.

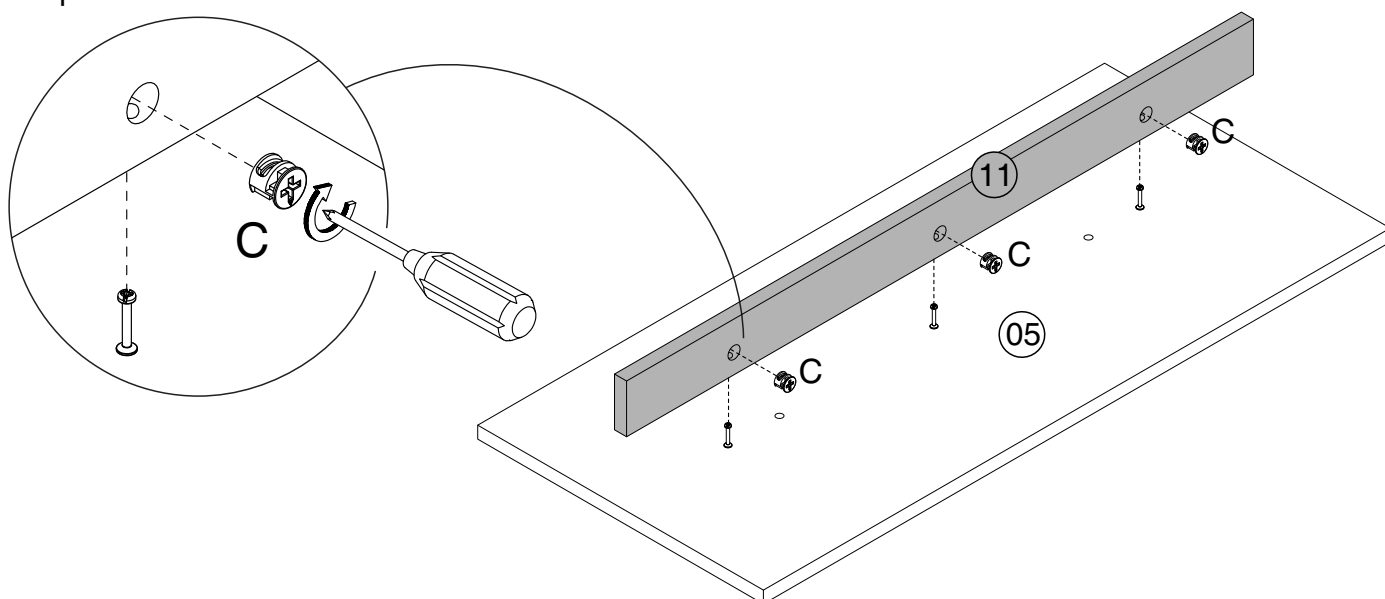

Étape / Paso 8

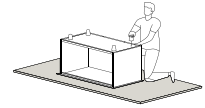

(FR) Insérez le support d'étagère (Q) dans les trous au milieu des panneaux latéraux. Placez ensuite l'étagère (5).

(ES) Inserte el soporte del estante (Q) en los orificios del centro de los paneles laterales. Luego, coloque el estante (5).

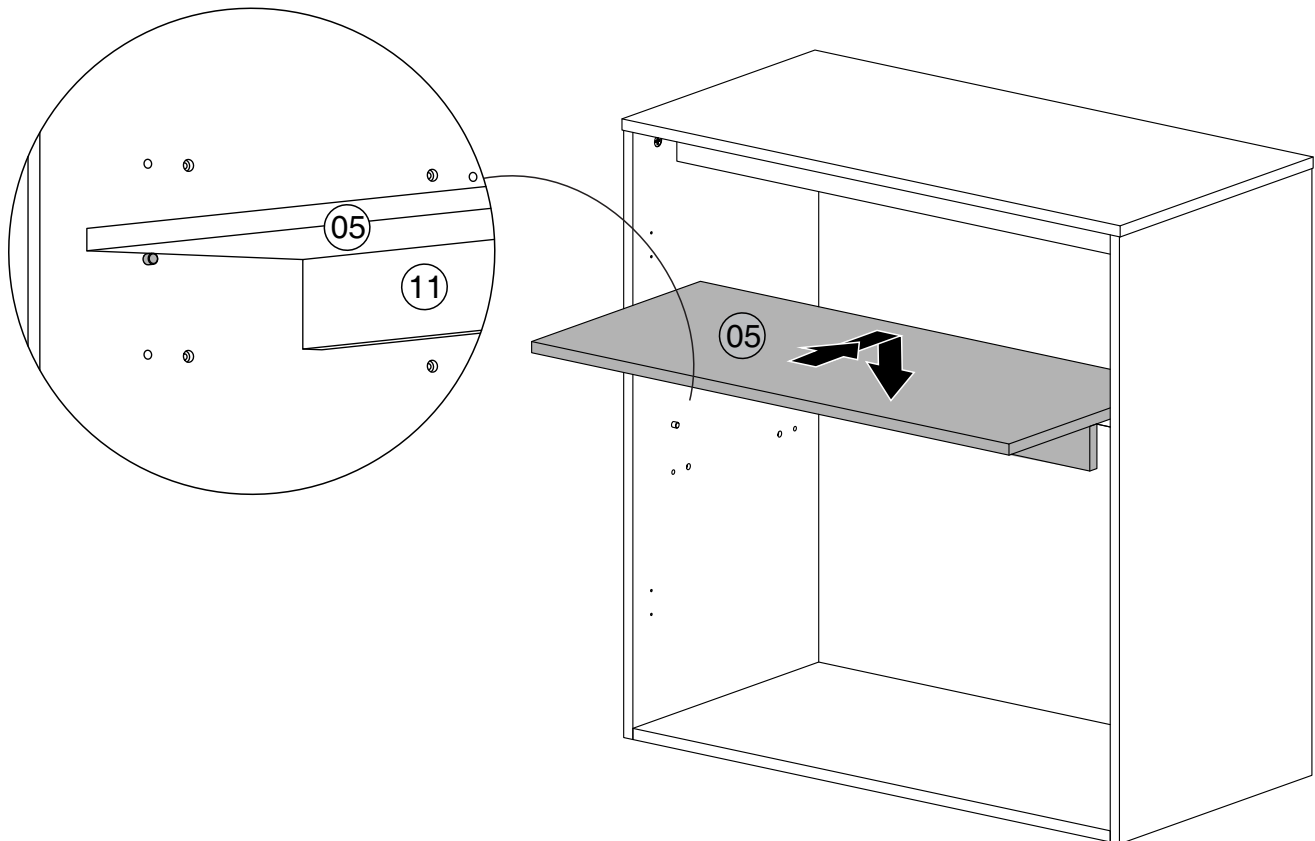
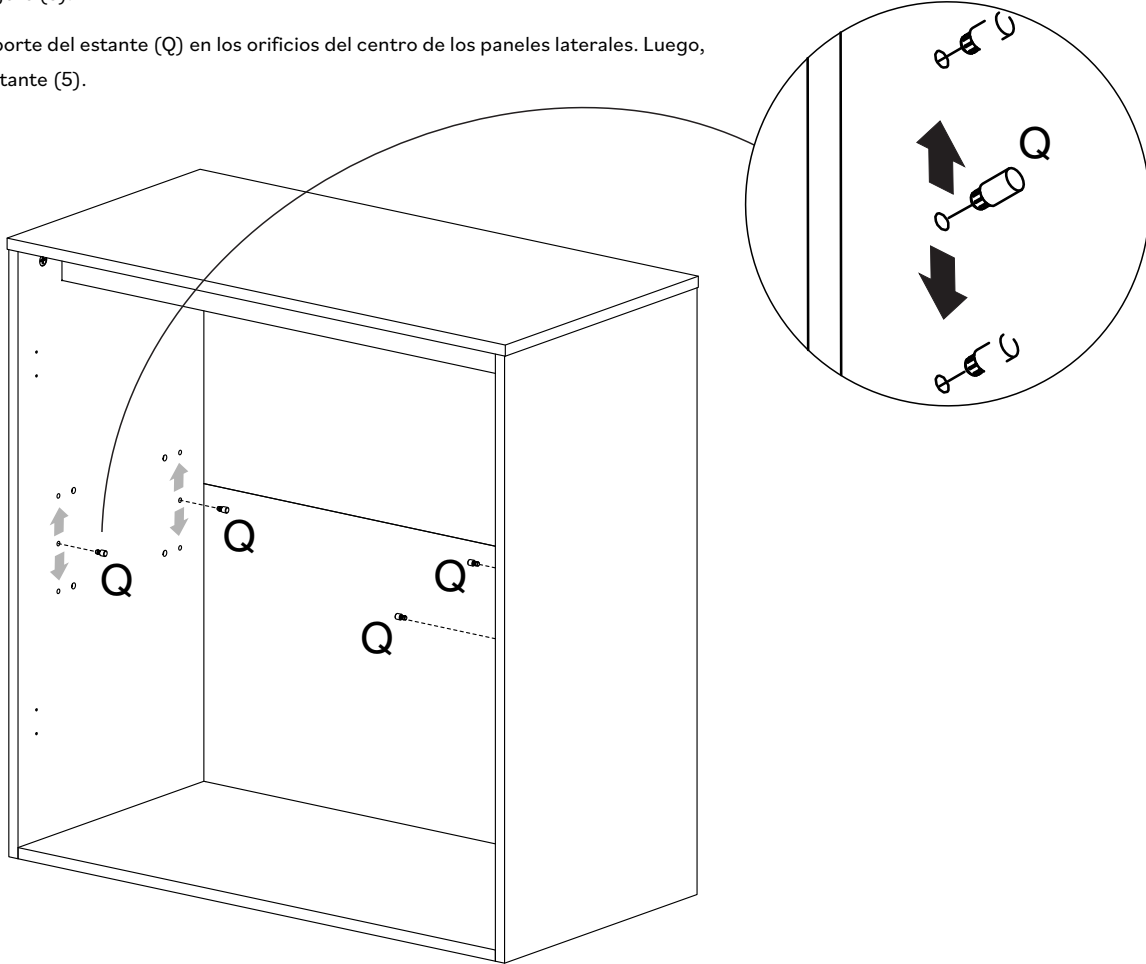

Étape / Paso 9

(FR)

Fixez la porte (8) sur le panneau gauche (2) à l'aide de vis (F) et d'un tournevis cruciforme.

(ES)

Fije la puerta (8) al panel izquierdo (2) usando tornillos (F) y un destornillador Phillips.

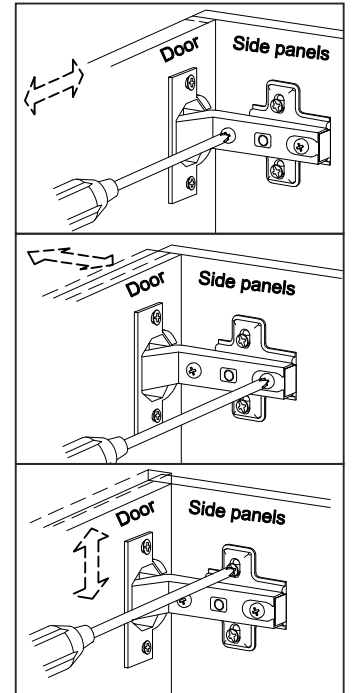
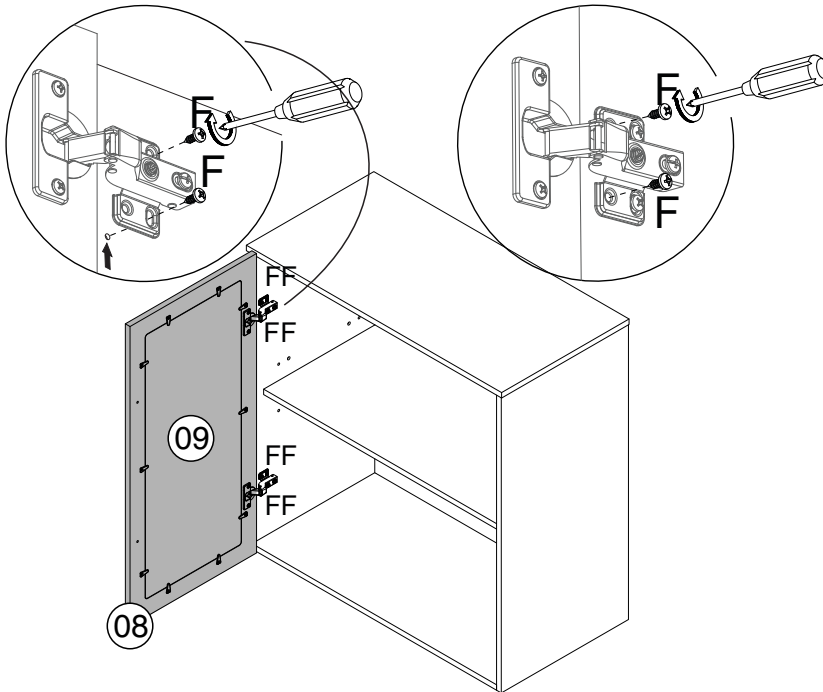

Étape / Paso 10

(FR)

Fixez la poignée (L) à l'aide de la vis (E) et d'un tournevis cruciforme.

(ES)

Asegure el mango (L) usando el tornillo (E) y un destornillador Phillips.

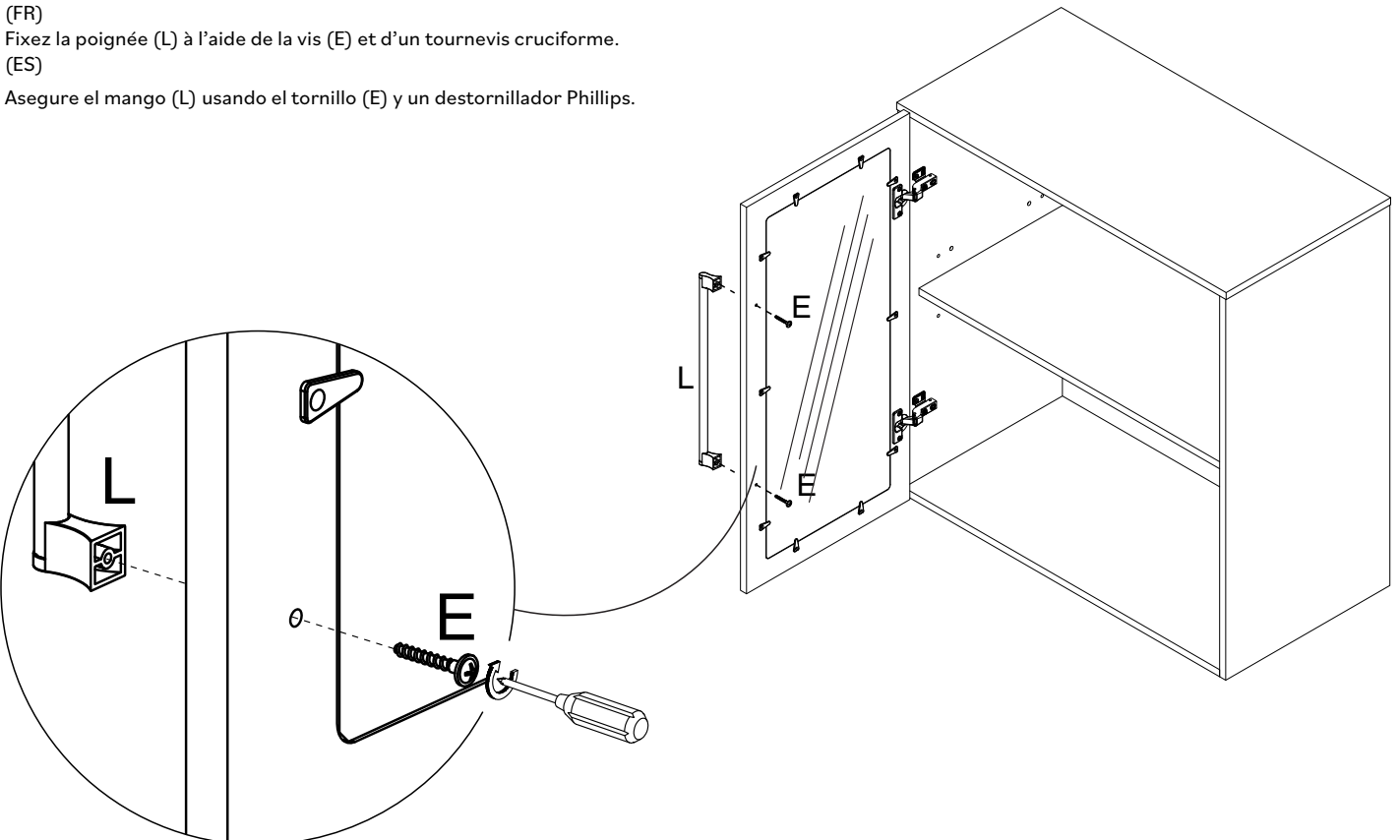

Étape / Paso 11

(FR)

Fixez la porte (8) sur le panneau droit (4) à l'aide de vis (F) et d'un tournevis cruciforme.

(ES)

Fije la puerta (8) al panel derecho (4) usando tornillos (F) y un destornillador Phillips.

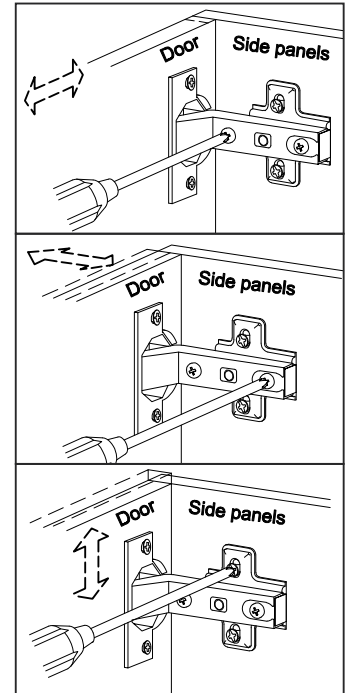
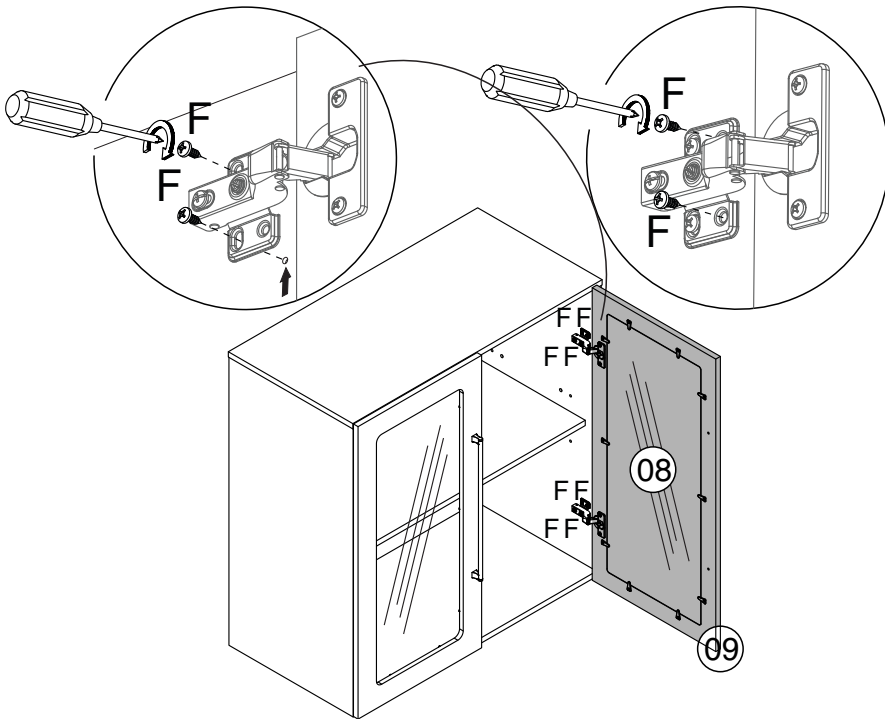

Étape / Paso 12

(FR)

Répétez l'étape 10.

(ES)

Repita el paso 10.

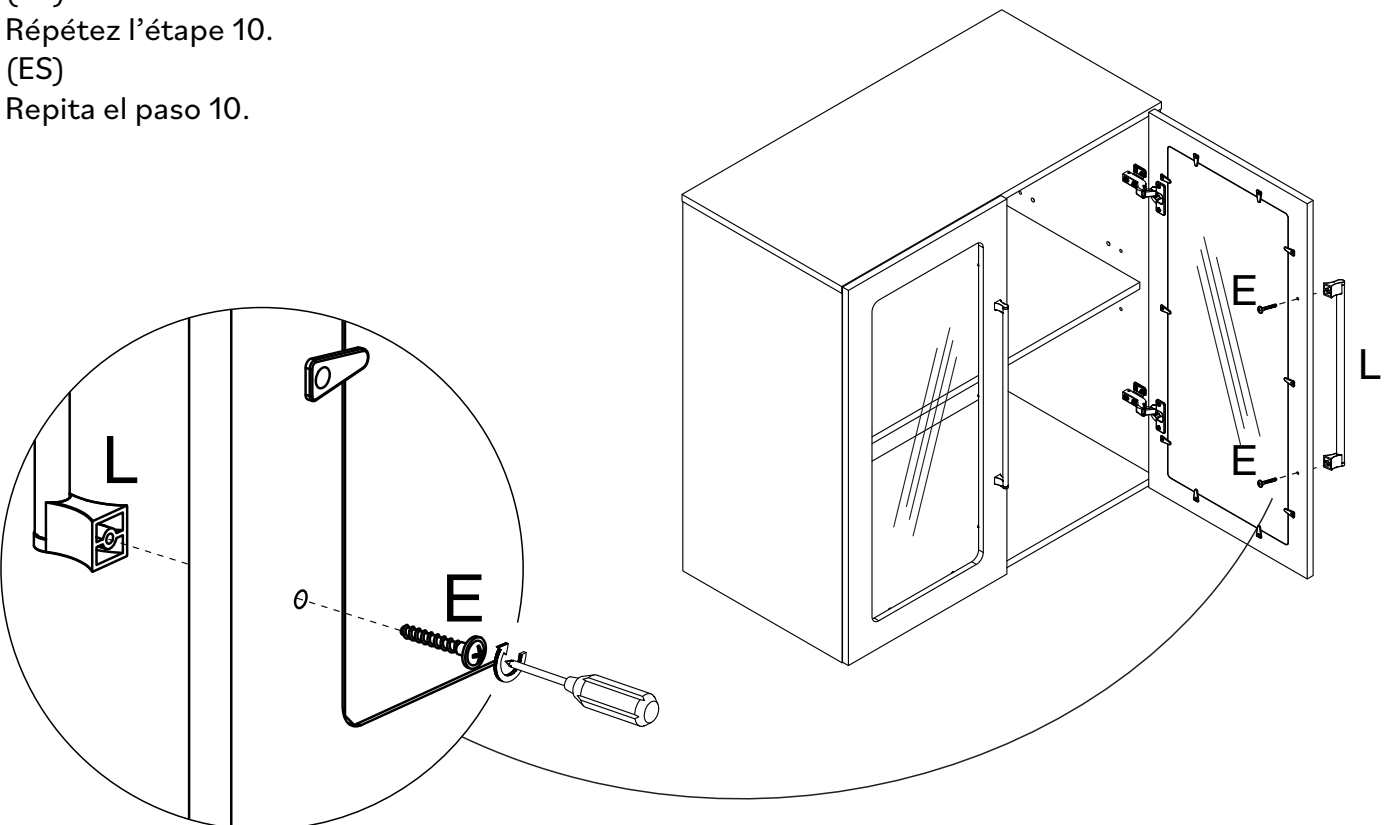

Étape / Paso 13

(FR)

Fixez le panneau arrière (6) à l'aide du support (K), de la vis (I) et d'un tournevis cruciforme.

(ES)

Asegure el panel posterior (6) usando el soporte (K), el tornillo (I) y un destornillador Phillips.

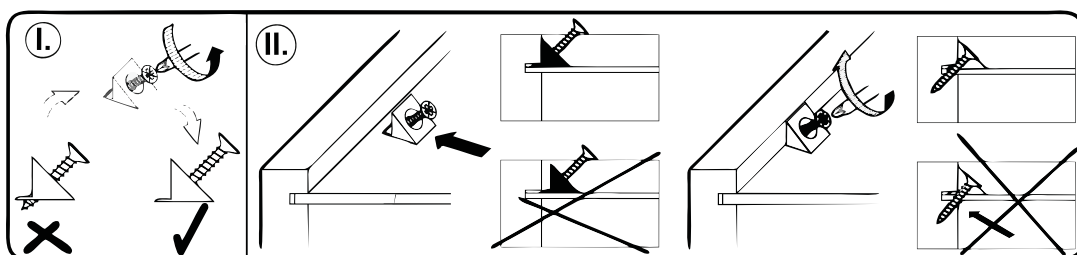
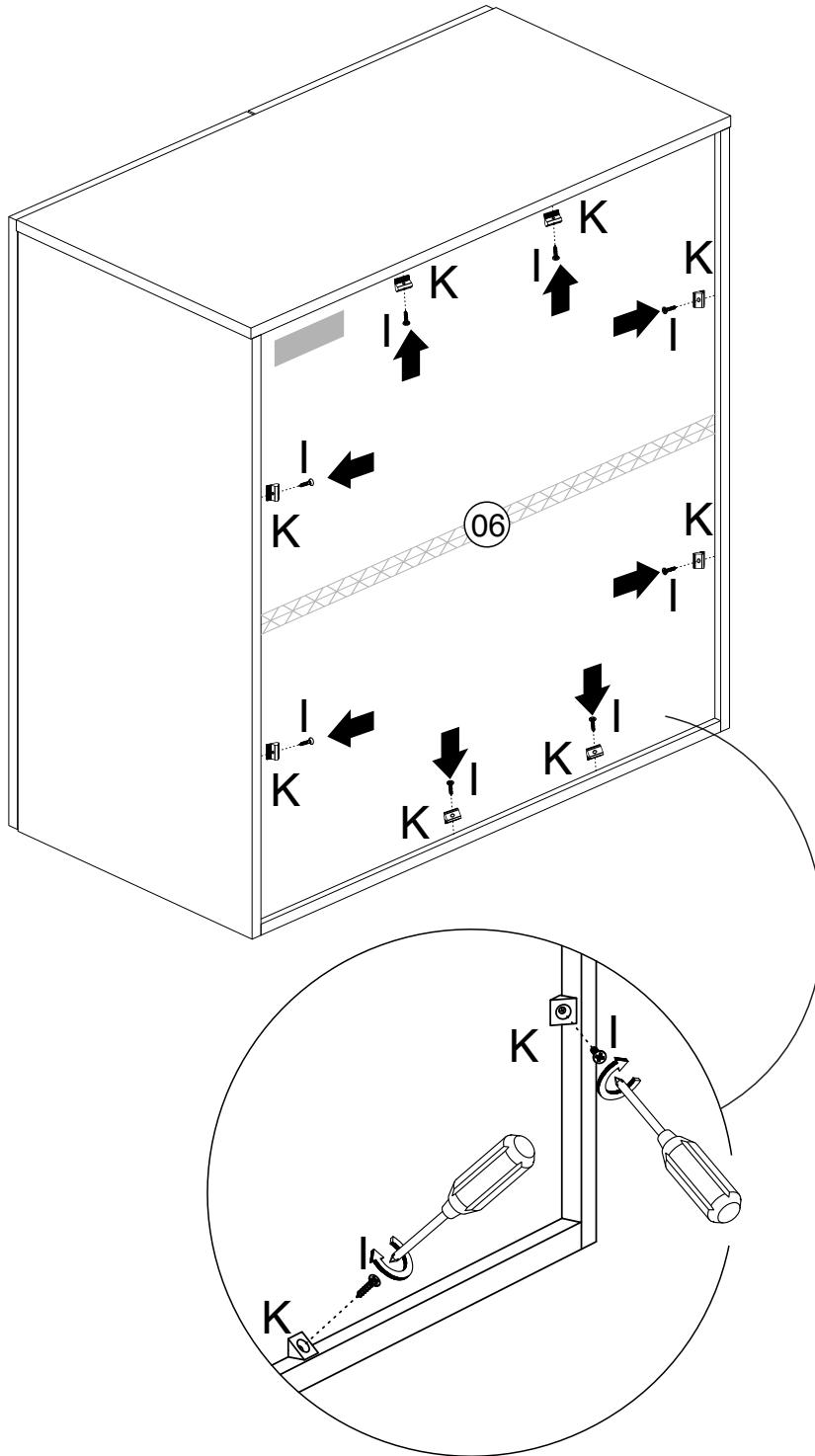

Étape / Paso 14

(FR)

Si vous n'utilisez pas votre nouvelle armoire sur une autre armoire modulaire Mia, vous pouvez fixer les pieds (7) à l'aide de la vis (H) et d'un tournevis cruciforme.

(ES)

Si no va a utilizar su nuevo gabinete encima de otro gabinete modular Mia, puede colocar los pies (7) usando el tornillo (H) y un destornillador Phillips.

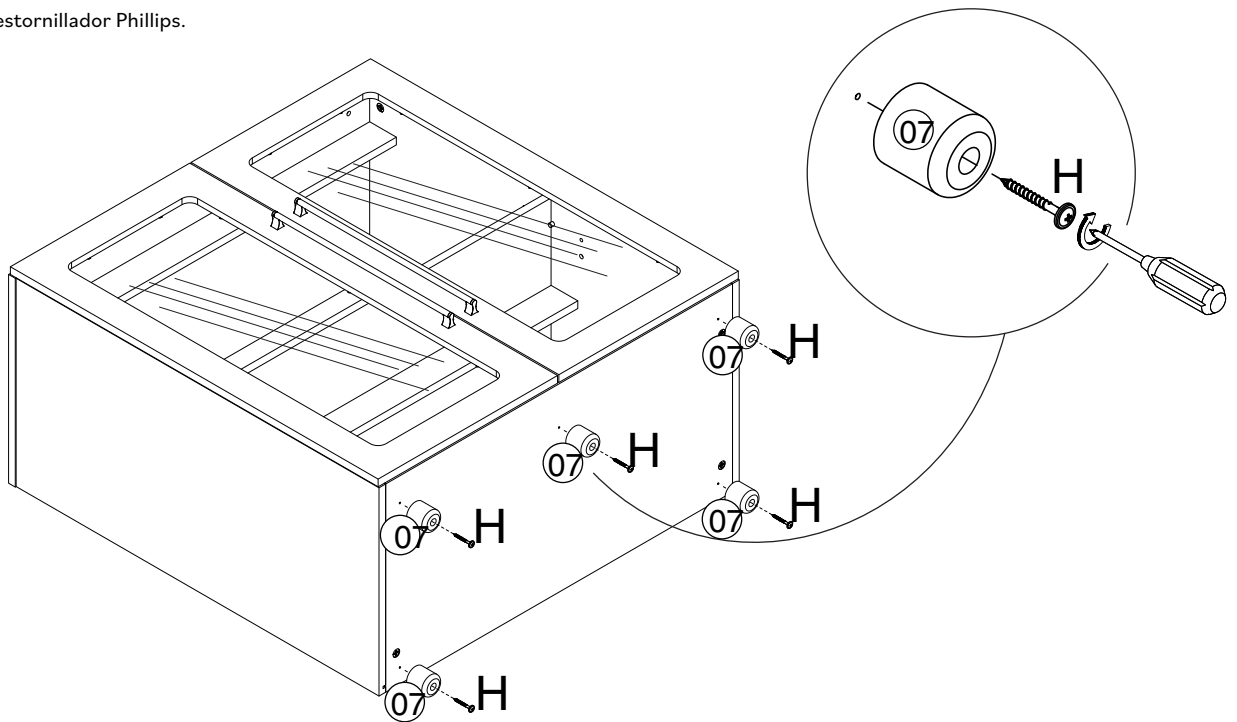

Mounting Options

Step 13

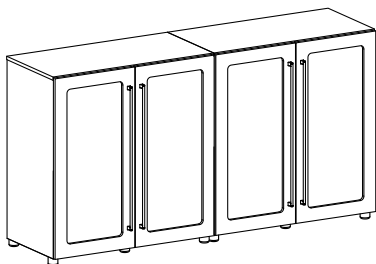

Step 14

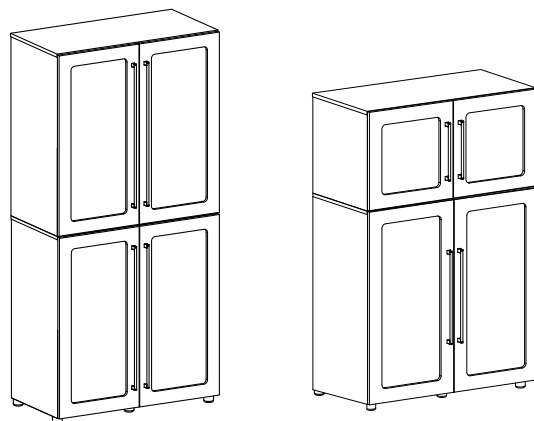

Étape / Paso 13

(FR)

Fixez vos armoires côte à côte à l'aide de vis (G) et d'un tournevis cruciforme. Les trous sont pré-perçés.

(ES)

Fije los gabinetes uno al lado del otro con tornillos (G) y un destornillador Phillips. Los agujeros ya están perforados.

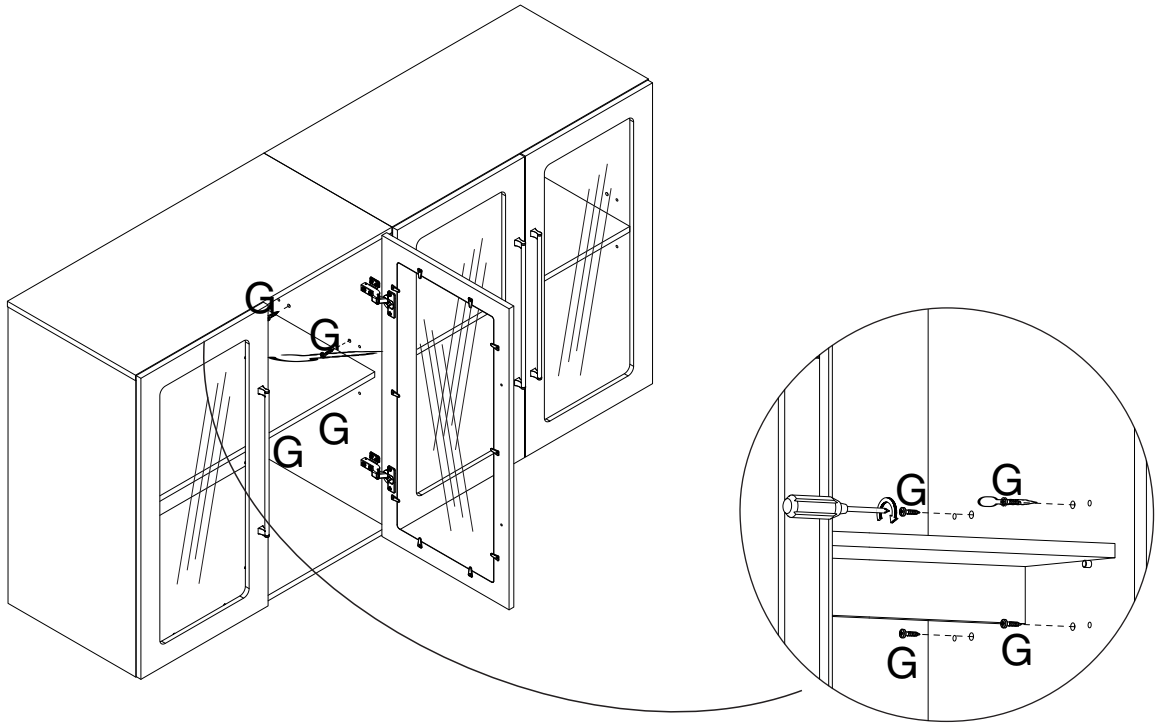

Étape / Paso 14

(FR)

Assemblez vos armoires modulaires les unes sur les autres à l'aide de vis (G) et d'un tournevis cruciforme. Les trous sont pré-perçés.

(ES)

Ensamble los gabinetes modulares uno sobre el otro con tornillos (G) y un destornillador Phillips.

Los agujeros ya están perforados.

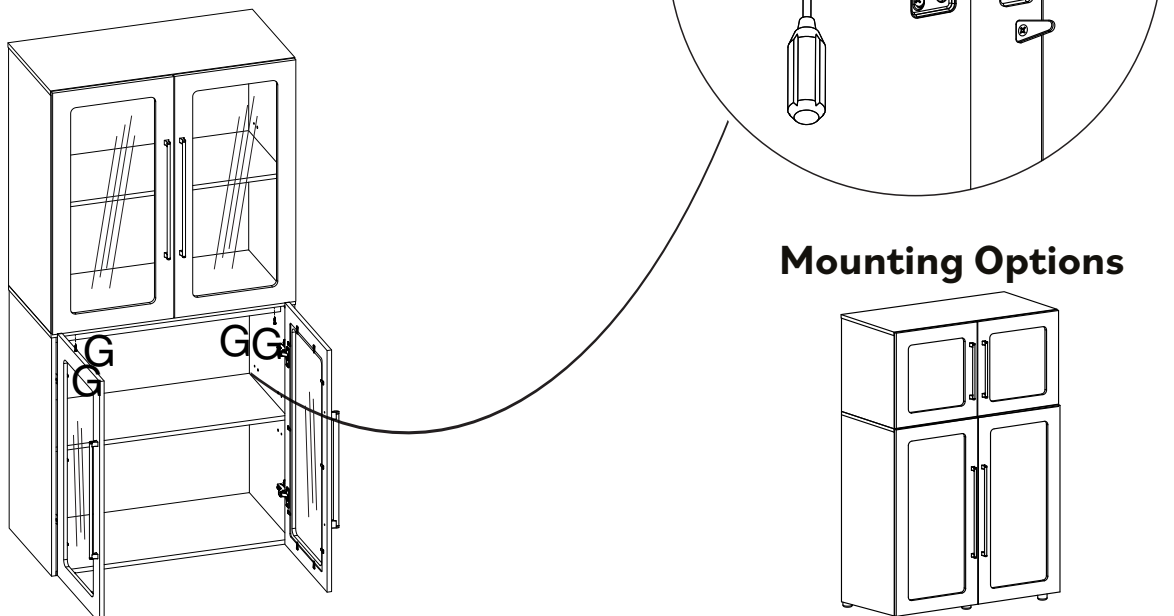

Étape / Paso 15

(FR)

Une fois tout en place, utilisez les autocollants (J) pour couvrir les trous supplémentaires.

(ES)

Con todo en su lugar use Pegatinas (J) para cubrir los agujeros extra.

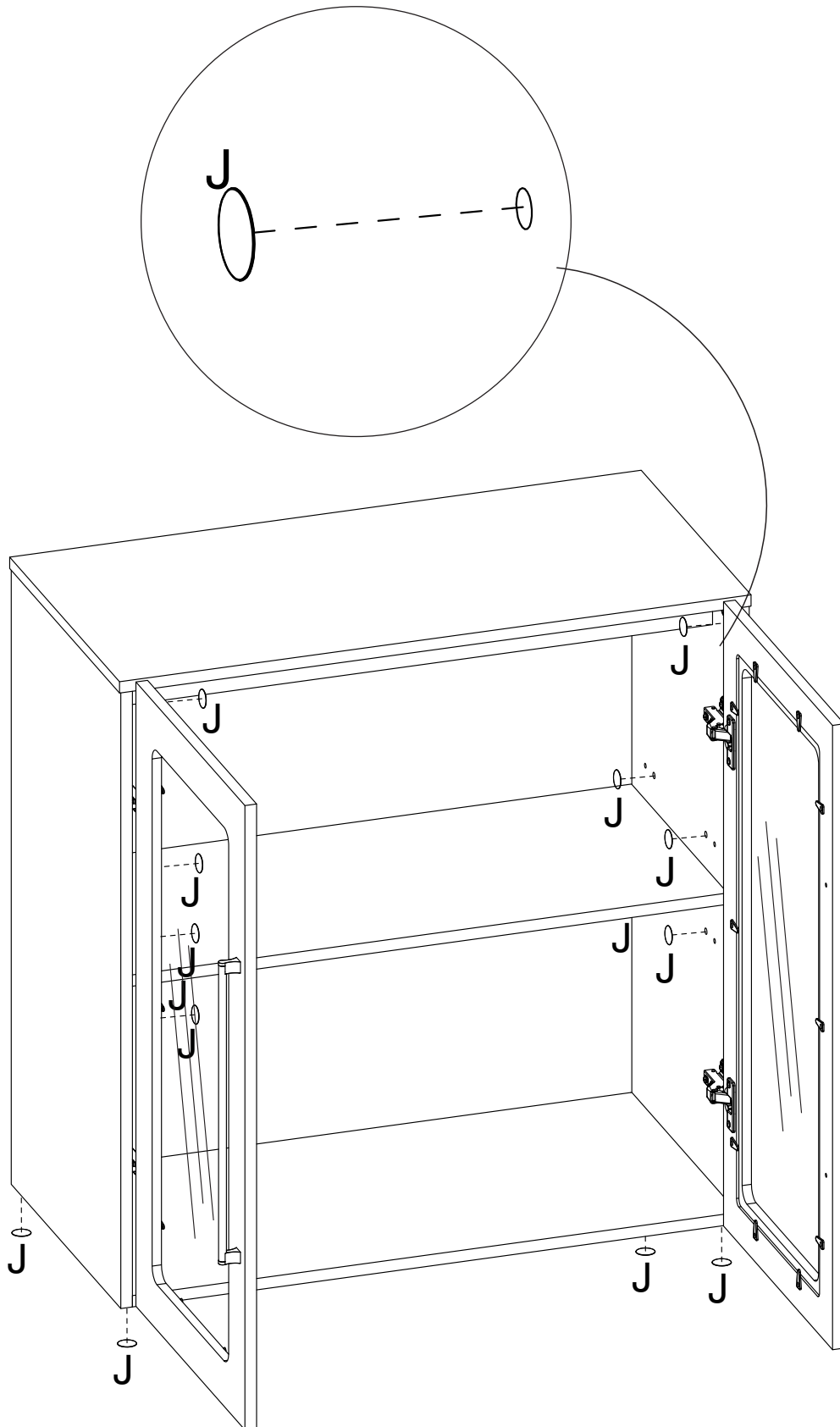

Étape / Paso 16

(FR)

Fixez votre meuble au mur. Fixez l'ancrage mural (P) à votre meuble à l'aide d'une rondelle (O), d'une vis (G) et d'un tournevis cruciforme.

(ES)

Fije el gabinete a la pared. Fije el anclaje de pared (P) al gabinete con la arandela (O), el tornillo (G) y un destornillador Phillips.

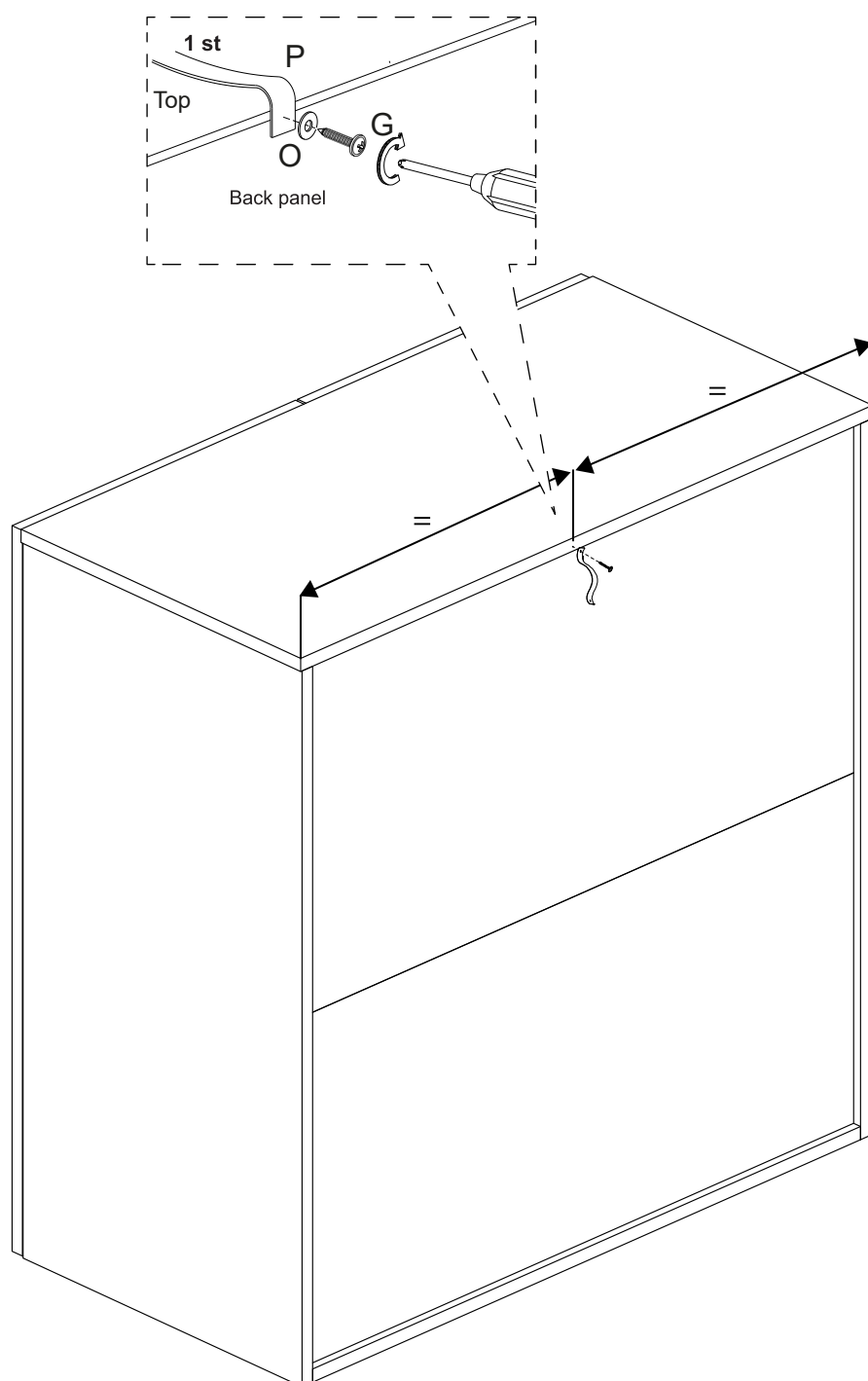

Étape / Paso 17

(FR)

Pour terminer, utilisez une douille en plastique adaptée à votre mur. Fixez ensuite la cheville murale (P) au mur à l'aide d'une rondelle (O) et d'une vis également adaptée à votre mur.

(ES)

Para finalizar, use un casquillo de plástico adecuado para su pared. Luego, fije el anclaje de pared (P) a la pared con la arandela (O) y un tornillo también adecuado para su pared.

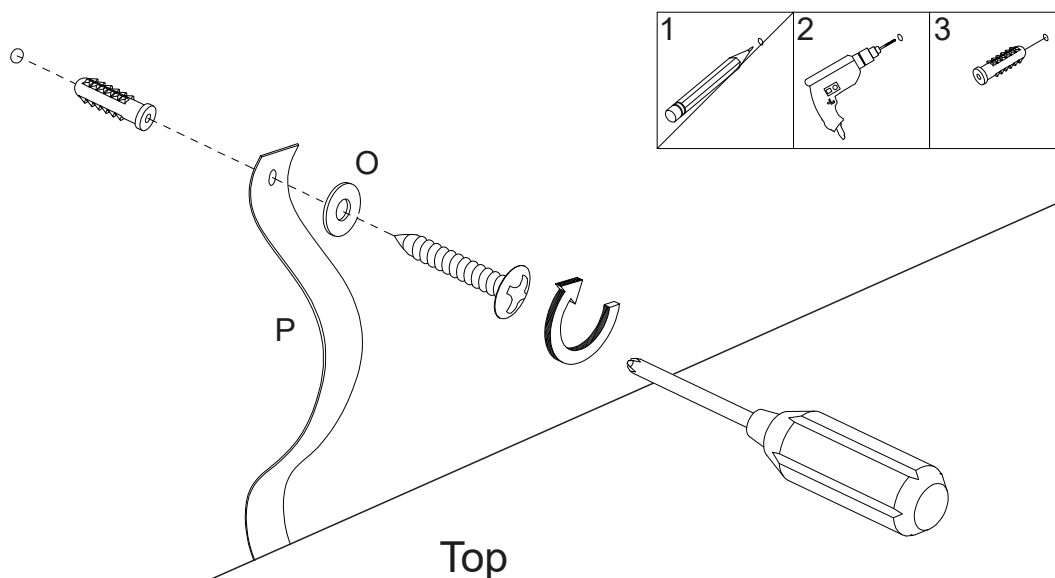

Avertissement

Des blessures graves, voire mortelles, peuvent survenir en cas de renversement de meubles. Pour éviter que le meuble ne bascule, nous recommandons de le fixer définitivement au mur. L'ancrage mural et les autres composants sont inclus dans ce produit. Assure-toi que les composants sont adaptés à tes murs avant l'installation, car différents matériaux de mur peuvent nécessiter différents types d'ancrages.

Advertencia

Pueden ocurrir lesiones graves o fatales debido a la caída de muebles. Para evitar que los muebles se caigan, recomendamos que se fijen permanentemente a la pared. El anclaje de pared y los herrajes están incluidos en este producto. Asegúrate de que los herrajes sean adecuados para tus paredes antes de la instalación, ya que diferentes materiales de pared pueden requerir diferentes tipos de anclajes.

Tu as réussi ! Profite de ton nouveau Armoire!

¡Lo ha conseguido! ¡Disfrute de su nueva Armario!

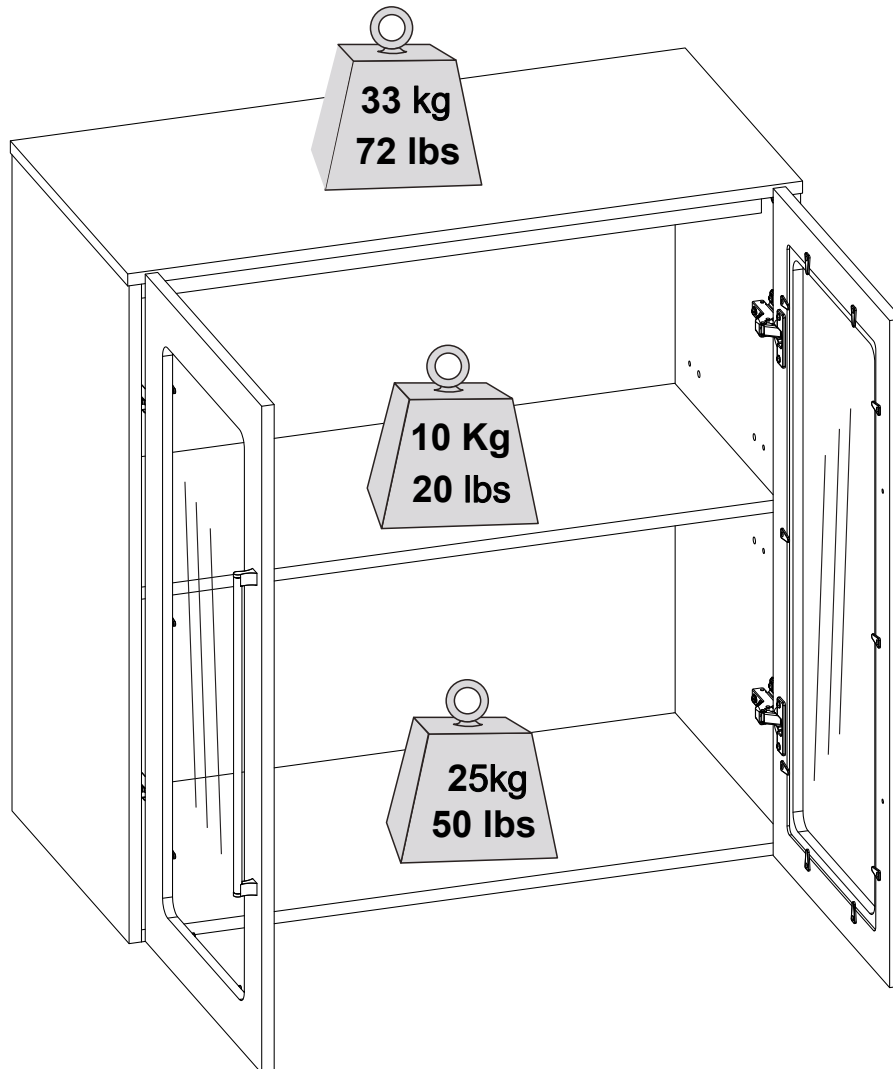

Bravo pour ton nouveau meuble !

Nous aimerions t'en entendre parler et le voir.

S'il te plait, laisse-nous un commentaire ou publie une photo sur

#mywalkeredisonhome

¡Enhorabuena por sus nuevos muebles!

Nos encantaría oírlo y verlo.

Por favor, déjenos un comentario o publique una foto con

#mywalkeredisonhome

Assembler des meubles peut parfois être compliqué.

Notre équipe de service client, située dans l'Utah, est là pour obtenir des informations sur les produits, aider pour l'assemblage d'un produit ou pour tout autre problème de support client.

Appelle-nous **801-433-3008**

Envoie-nous les e-mails à service@walkeredison.com

Visite notre site accueil au client à
walkeredison.com/pages/customer-service

Nous sommes disponibles pour t'aider du Lundi au Jeudi de 8 am - 5 pm, Vendredi de 8 am - 3 pm MST.

Pour plus de détails sur les vidéos d'assemblage,
les instructions d'assemblage,
les pièces de rechange et le service client.
NUMÉRISER ICI.



Pour le nettoyage, n'utilise jamais d'abrasifs, utilise un chiffon doux et de l'eau avec du savon neutre pour nettoyer les meubles.

A veces, montar muebles puede resultar complicado.

Nuestro equipo de atención al cliente, ubicado en Utah, está a su disposición para informarle sobre los productos, ayudarle a montarlos o resolver cualquier otro problema de atención al cliente.

Llámenos **801-433-3008**

Envíenos un correo electrónico a service@walkeredison.com

Visite nuestra página web de atención al cliente
walkeredison.com/pages/customer-service

Estamos a su disposición para ayudarle de lunes a jueves de 8:00 a 17:00, viernes de 8:00 a 15:00 MST.

Para más detalles sobre videos de montaje,
instrucciones de montaje, piezas de recambio y
servicio de atención al cliente
ESCANEE AQUÍ.



Para la limpieza, nunca utilice productos abrasivos, utilice un paño suave y agua con jabón neutro para limpiar los muebles.