

ASSEMBLY INSTRUCTION

DINING 2 - TONED OAK SOLID TOP TABLE

Component List

A Table Top

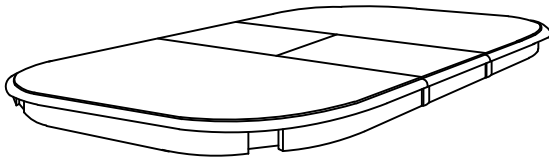

1pc

B Table Leg

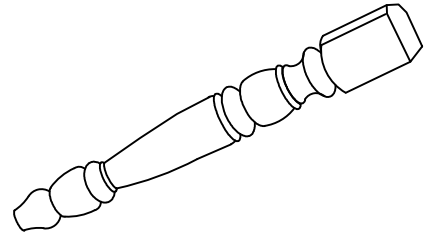

4pcs

Hardware List

1 Bolt $\phi 5/16"$

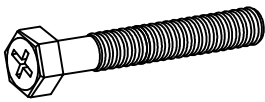

8pcs

2 Lock Washer $\phi 5/16"$

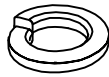

8pcs

3 Flat Washer $\phi 5/16"$

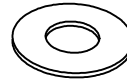

8pcs

4 Wrench #12.8



1pc

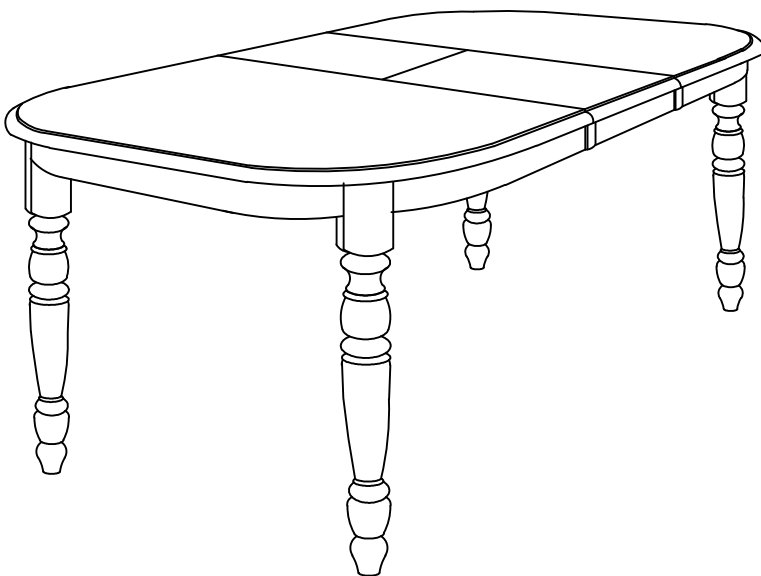

This page lists all the contents included in the box. Please take the time to identify the hardware as well as the individual components to this product. As you unpack and prepare for assembly, place the contents on a carpeted or padded area to protect them from damage.

1

Turn the Table Top (A) upside down on a soft surface such as carpet. Fix the Table Leg (B) to the corner of the apron by using Flat Washer (3), Lock Washer (2), Bolt (1) and tighten with Wrench (4) as per illustration.

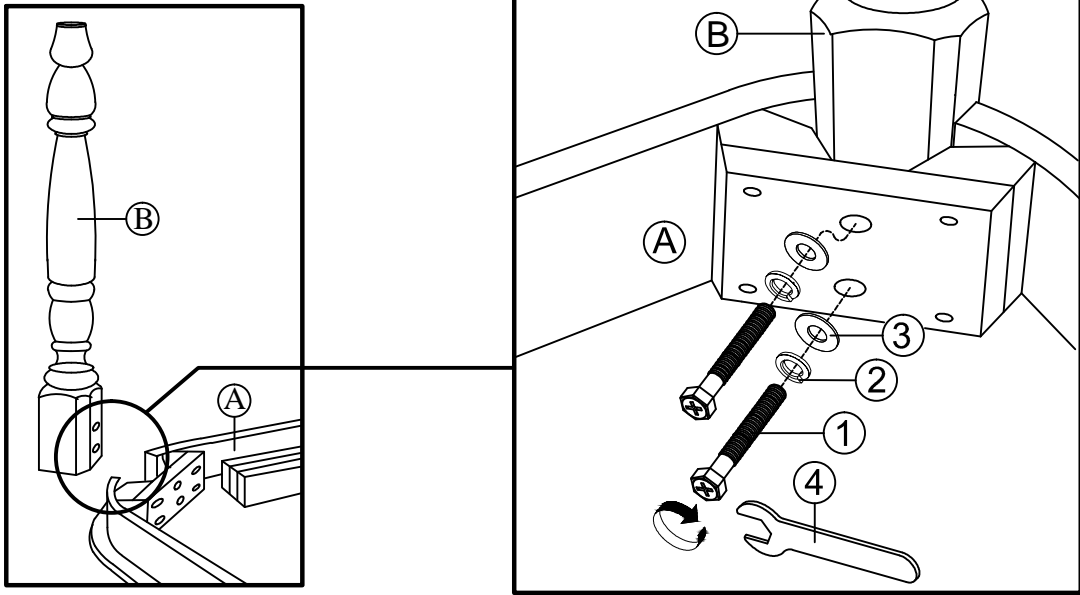

2

Turn the Table unit upright.

(Fig.A)

Open the hook at underneath of the top assembly. Pull out the leaves as show in the illustration.

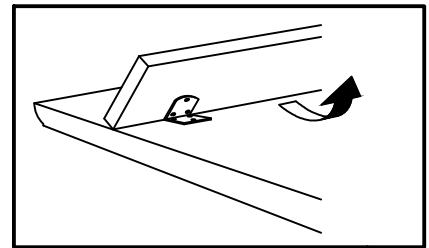
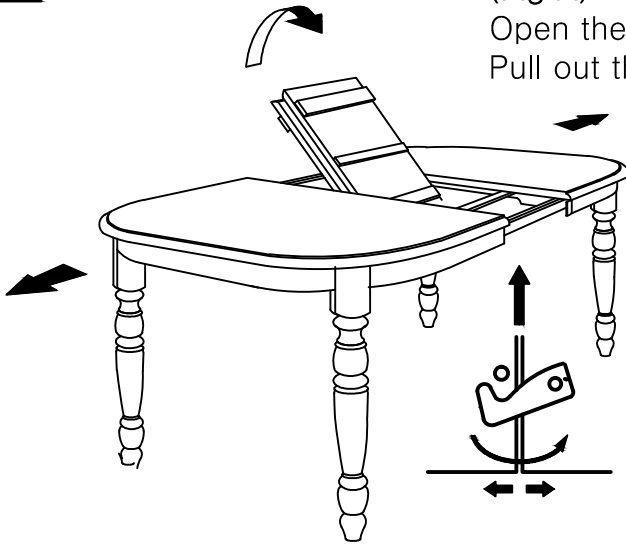

(Fig.B)

Raise the leaves apron and close up the Table Top.

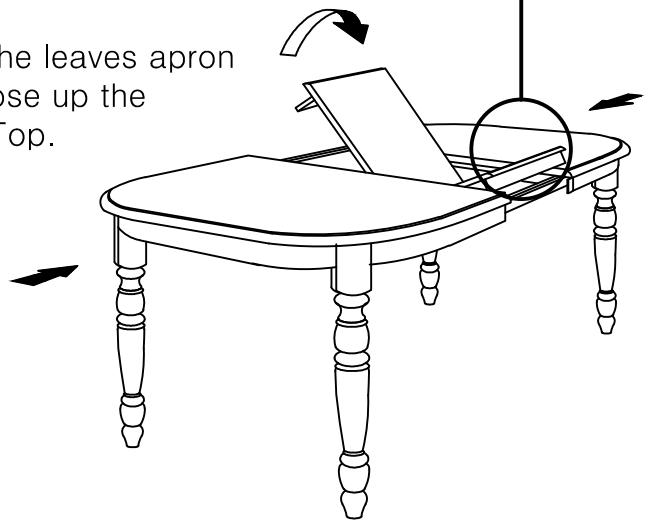

(Fig.C)

Fix the leaves by locking back the hook at underneath of the top assembly.

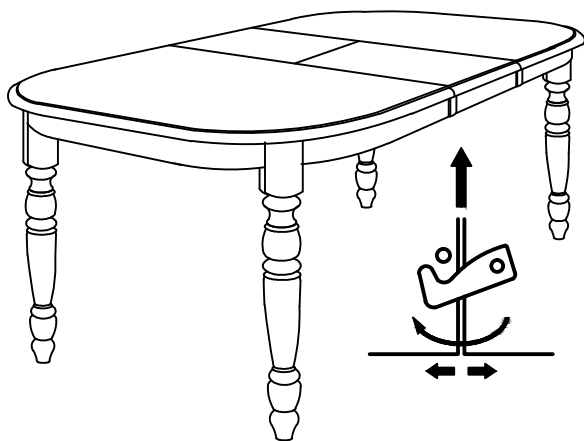

Cleaning & Care

Treat surface with care. Surface is resistant to scratches but is not scratch resistant. Clean surface with a dry or damp soft cloth. Do not use abrasive cleaners. Hardware may loosen over time. Periodically check that all connections are tight.

ASSEMBLY INSTRUCTION

TWO TONE FINISH SIDE CHAIR

A Chair Back

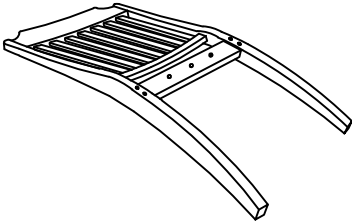

1pc

B Box Frame

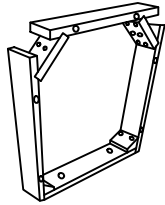

1pc

C Wooden Seat



1pc

D Front Leg

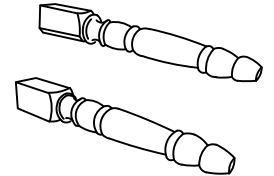

2pcs

E Jcbc Bolt M6 x 70mm

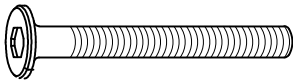

8pcs

F Jcbc Bolt M6 x 40mm

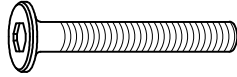

2pcs

G Lock Washer M6



10pcs

H Flat Washer M6 x 19mm



10pcs

I Csk-Cb Screw #8 x 1"

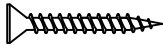

6pcs

J Allen Key M4 x 60mm



1pc

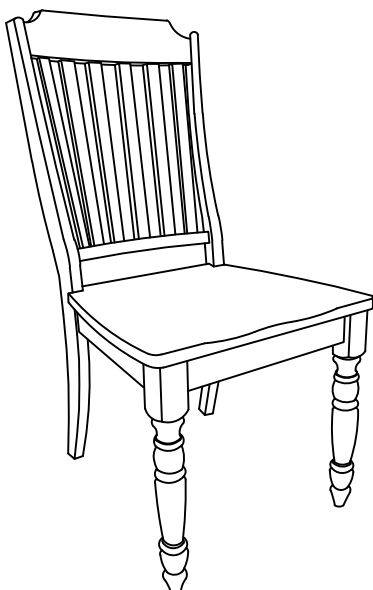

This page lists all the contents included in the box. Please take the time to identify the hardware as well as the individual components to this product. As you unpack and prepare for assembly, place the contents on a carpeted or padded area to protect them from damage.

1

Put the Chair Back (A) Box Frame (B) upside down on the soft and smooth surface. With assistance attach Box Frame (B) onto Chair Back (A). Then insert Jcbc Bolt (E), Lock Washer (G) and Flat Washer (H) into predrilled holes of each corner, by using Allen Key (J). Insert Jcbc Bolt (F), Lock Washer (G) and Flat Washer (H) into the predrilled holes of the middle of Chair Back (A), by using Allen Key (J). Do not fully tighten the bolts in this step.

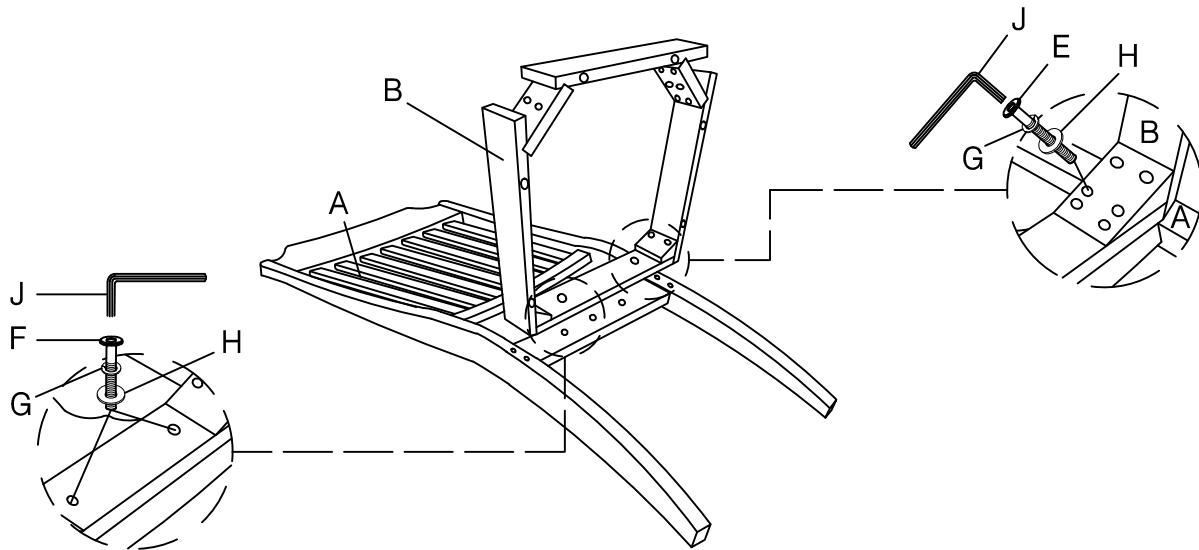

Take the Allen Wrench, and turn the bolts until the legs are secure.
DO NOT TIGHTEN COMPLETELY.
Stop when you feel you are adding force to tighten the bolt.

2

Attach Chair Legs (D) and corner of Box Frame (B), insert Flat Washer (H), Lock Washer (G) and Jcbc Bolt (E) using Allen Key (J).

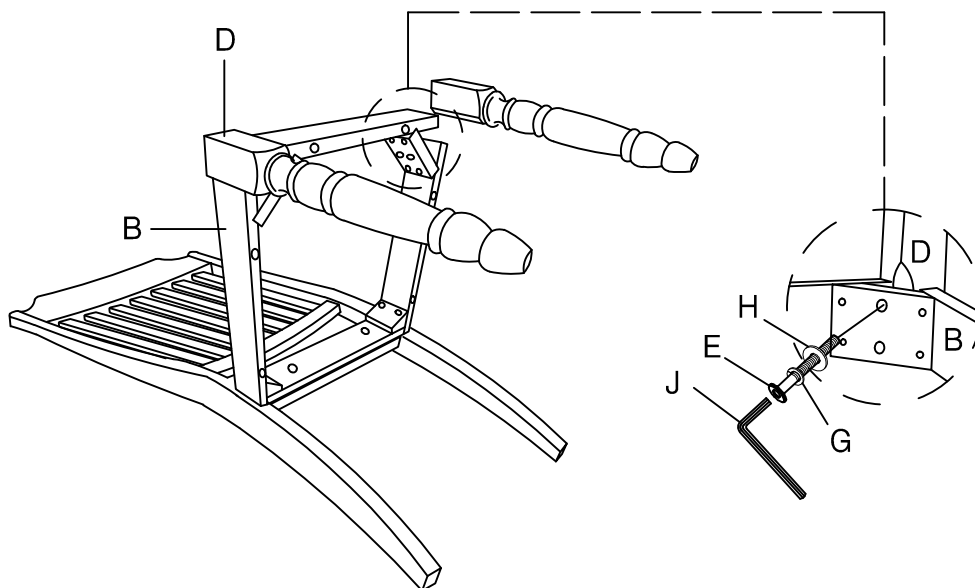

3

Attach Wooden Seat (C) and Box Frame (B) with Csk-Cb Screw (I) by using Screwdriver (not included). Tighten all wood screws in this step.

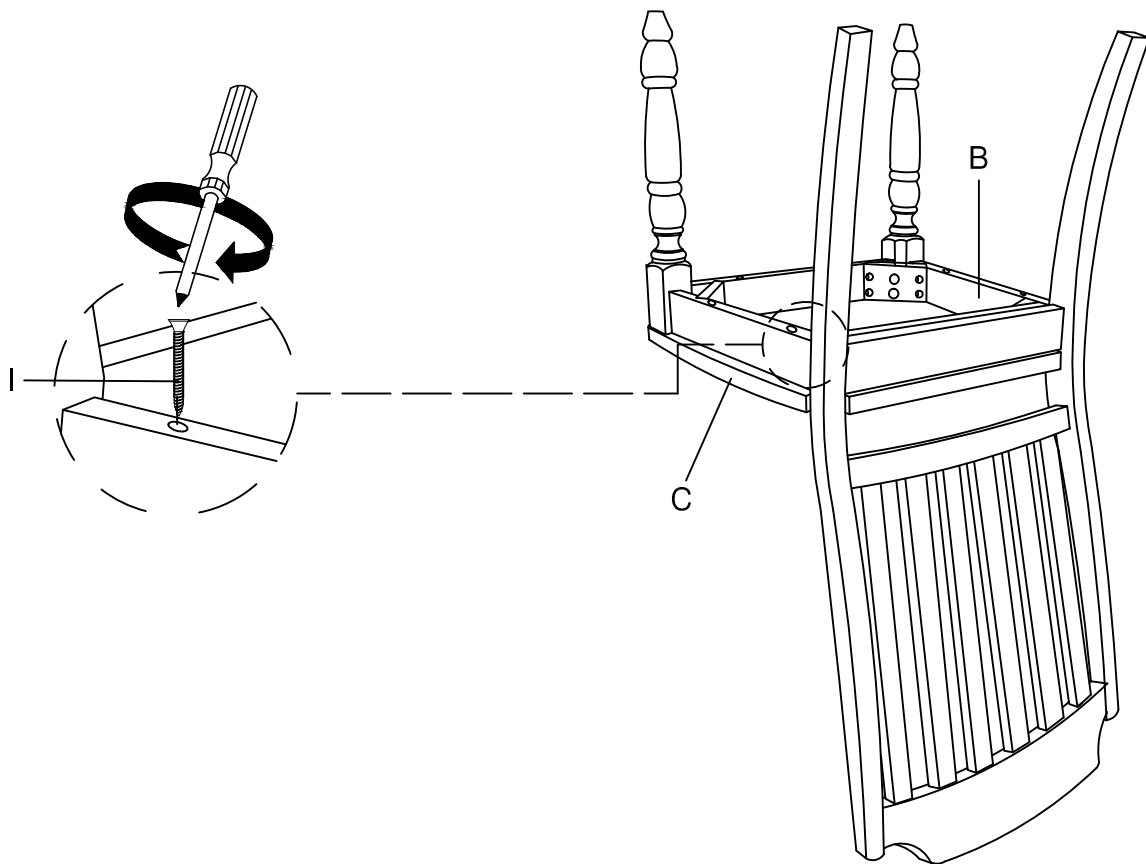

Stand chair up on an even surface and check that it is balanced. If there is a slight wobble, apply downward pressure in the corner where a leg is uneven. Keeping pressure in that corner, tighten all bolts. If balanced, apply downward pressure evenly in the center and tighten all bolts. Do not over-tighten beyond hole depth.

Helpful Tip:- Instead of applying downward pressure while reaching under to tighten bolts, have someone sit in the chair while you tighten the bolts.

Cleaning & Care

Treat surface with care. Surface is resistant to scratches but is not scratch resistant. Clean surface with a dry or damp soft cloth. Do not use abrasive cleaners. Hardware may loosen over time. Periodically check that all connections are tight.