

TIGER PRESSURE TREATED OCTAGONAL

GENERAL ASSEMBLY INSTRUCTIONS

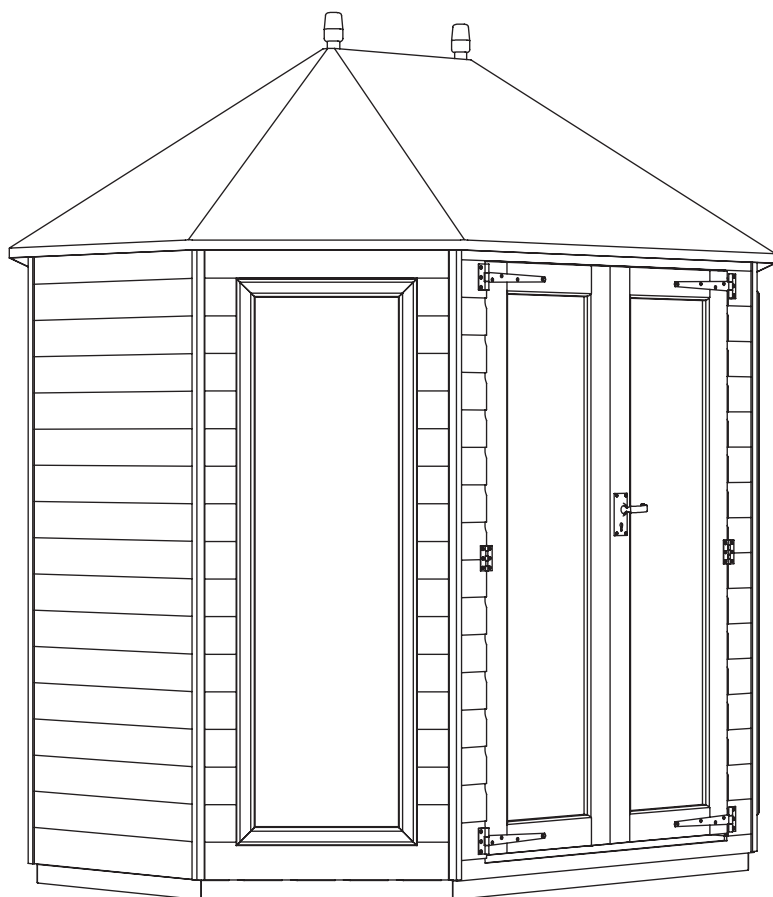

BEFORE YOU GET STARTED

PLEASE READ INSTRUCTIONS CAREFULLY

- Check the pack and make sure you have all the parts listed.
- When you are ready to start, make sure you have the right tools at hand (not supplied).
- Ensure there is plenty of space and a clean dry area for assembly.

TIMBER

As with all natural materials, timber can be affected during various weather conditions. For the duration of heavy or extended periods of rain, swelling of the wooden panels may occur. Warping of the wood may also occur during excessive dry spells due to an interior moisture loss. Unfortunately, these processes cannot be avoided but can be mitigated. It is suggested that the outdoor building is sprayed with water during extended periods of warm sunshine and sheltered as much as possible during rain or snow.



SUMMER
CONTRACTION



WINTER
EXPANSION



WOOD WARPING
MAY OCCUR

To validate your guarantee and ensure longevity of the product, it is ESSENTIAL that your building is treated with an appropriate high-quality water-resistant preservative AFTER assembly, both internally and externally, and annually thereafter. All glazing units must be sealed (internally and externally) with silicone or other watertight sealant.

BUILDING A BASE

Care must be taken to ensure the product is placed on a suitable base. When thinking about where the building and base is going to be constructed, ensure that there will be access to all sides for maintenance work and annual treatment.

Ensure the base is firm and level and is built on firm ground, to prevent distortion.

The constructed base must be at least the size of product as referenced in supplied construct diagram. It is also recommended that the floor be at least 25mm above the surrounding ground level to avoid flooding.

TYPES OF BASE

- Durable plastic grid*
- Concrete 75mm laid on top of 75mm hard-core.
- Slabs laid on 50mm of sharp sand.
- Timber Base - Self constructed/Buy pre-made.



PLASTIC BASE



CONCRETE BASE

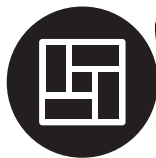

SLAB BASE



TIMBER BASE



BROKEN SLABS



BARE SOIL



LOOSE GRAVEL

**We recommend a Fastfit EcoBase for your building. It is durable, lightweight, flexible and easy to put in place. Please see [tigersheds.com](https://www.tigersheds.com) for details.*

CAUTION:

All buildings should be erected by two competent adults.



CAUTION:

It is advisable to wear gloves during building installation.



The mark of responsible forestry
FSC® C125286



MADE IN THE UK SINCE 1913.

We have been making our high quality, great value garden buildings here in Britain for decades.

Pressure Treated Buildings & Treatment:

Our Pressure Treated (or tanalised) Range of buildings are impregnated with Tanalith-E - the latest generation wood preservative. This has a pale green tint to the timber as the treatment is a copper-based product designed to limit the chance of rot and insect attack. Once erected, your building should be treated annually, both internally and externally with an appropriate high-quality water-resistant preservative.

Whilst all products manufactured are made to the highest standards of safety, we cannot accept responsibility for your safety whilst erecting or using this product.

GO WITH THE PRO!

We understand how busy life can be. Our Pro-Installation service can take the stress and strain out of assembling your quality Tiger building for you. We recommend using professional and dedicated installers to erect your building. With their knowledge and experience, they will ensure that your cabin is put properly in place ready for you to enjoy your space for years to come.

If you have not booked our Pro-Installation service and would like to arrange an installation, please contact our friendly customer support team on **0113 205 4189** (Mon - Fri 9am-5pm) or email **sales@tigersheds.com**.

- The pro-install team will contact you to arrange a suitable time and date for the fitting.
- Sit back, relax and let our professional home installation service do all the hard work for you!
- Please view the Pro Installation page on tigersheds.com for full terms & conditions and to see if your postcode area is covered by our Pro-Install teams.

BEFORE YOU GET STARTED - PRE ASSEMBLY

TOOLS REQUIRED:

We recommend using the following tools (not supplied):



HAMMER



RUBBER Mallet



DRILL



LADDER



TAPE MEASURE



SHARP KNIFE



SPIRIT LEVEL



SCREWDRIVER +



WOOD SAW



SPANNER

FIXING KIT GUIDES:

FX06 - NAIL KITS HEAVY DUTY

For Heavy Duty Shed Products:

- CN10** Clout Nails (*13mm Galvanised - QTY 450*)
- PP25** Panel Pins (*25mm - QTY 200*)
- N40** Nail (*40mm Galvanised - QTY 85*)
- NG5** Nail (*65mm Galvanised - QTY 20*)
- N100** Nail (*100mm Galvanised - QTY 100*)
- CB100** Coach Bolts (*100mm - QTY 8*)

BUILDING PACK CONTENTS:

For full details of what should be included please see the itemised packing list that is supplied with the delivery. They are also available on request in pdf form from our helpful Customer Support team – please call: **0113 205 4189** or use the “Items Delivered Query” form at [tigersheds.com/contact](https://www.tigersheds.com/contact).

REMOVE TRANSPORT BLOCKS

- Make sure transport blocks have been removed from side panels before assembly. *(Detail 1)*

NOTE: HAMMER OFF SIDEWAYS. DO NOT PRISE OFF

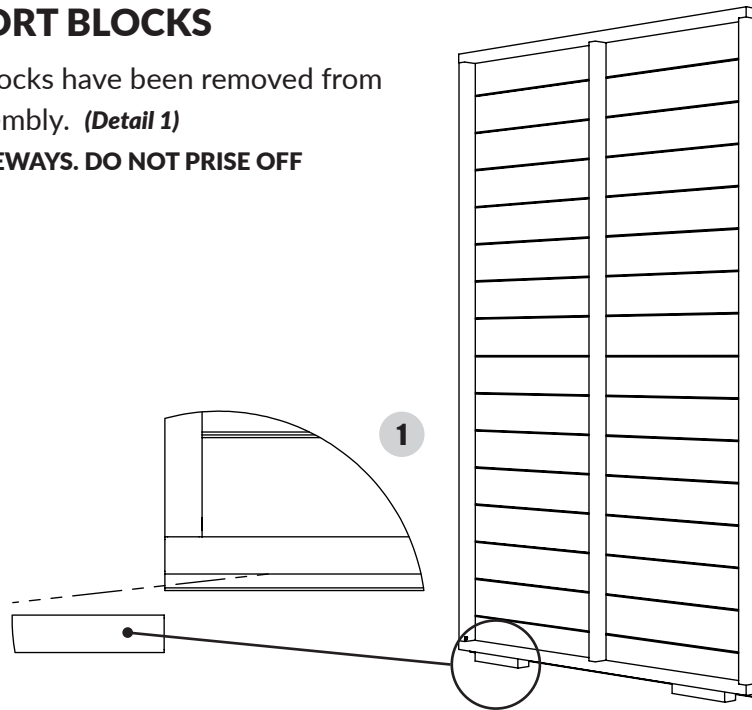

- Assembly is straightforward if you follow these step-by-step instructions.
- We recommend getting everything aligned properly before screwing together and that **screw holes should be pre-drilled to avoid splitting the timber.** *(Do not come pre-drilled).*

IMPORTANT

- Before assembly, please make sure you have a suitable base ready to erect your building on.
- Your base **MUST** be firm and level to ensure that the building is assembled properly and is square.
- **DO NOT** start your build until you have checked that all the parts of your building are present, correct and in a suitable condition.
- Panels may have become twisted during loading/unloading and/or transportation. Please check that all framing and cladding are square before beginning assembly.
- Make sure all transport blocks have been removed from panels.
- If you are organising a third party to install your building, it is best practice not to schedule this immediately on receipt of your order, to give you time to check your delivery

Step 1:

LAYING THE FLOOR

- **SINGLE FLOOR** - Lay floor down in the desired position. *(Detail A)*

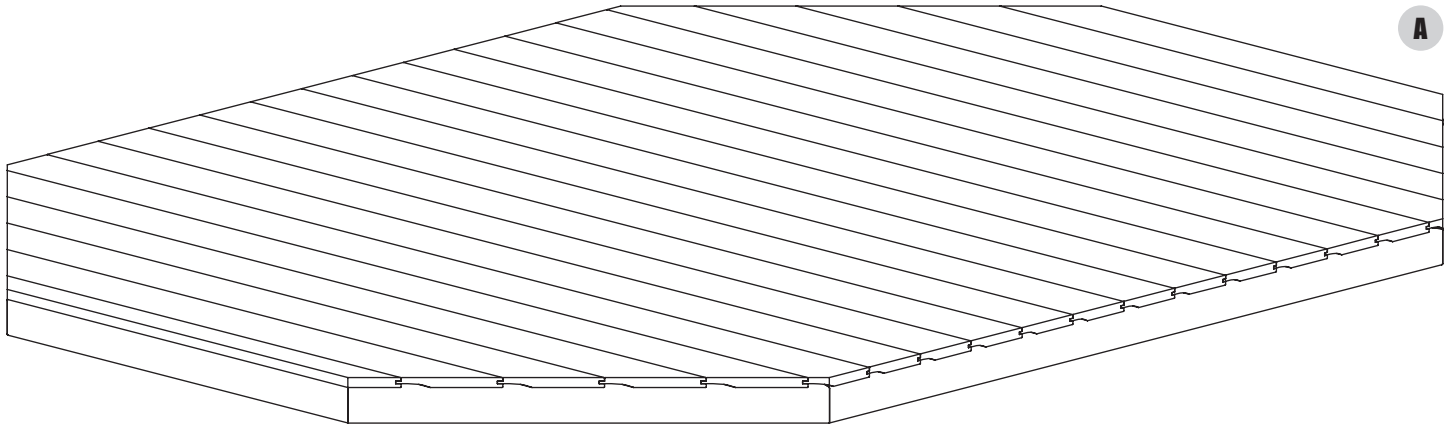

Step 2a:

INSTALLING SIDE AND GABLE PANELS

- Position blank panel along back edge of floor. Offer up panels either side. *(Detail B1)*
NOTE: CHECK THAT ALL PANELS ARE AT RIGHT ANGLES TO EACH OTHER AND THE FLOOR.
NOTE: CHECK ALL TRANSPORT BLOCKS HAVE BEEN REMOVED BEFORE FITTING PANELS.
- Secure together with 4x N100 evenly spaced. *(Detail B2)*
- Repeat process for remaining panels.
- When fitting the door panel, you will find it easier to open the doors before securing together.
DO NOT FIX TO FLOOR.

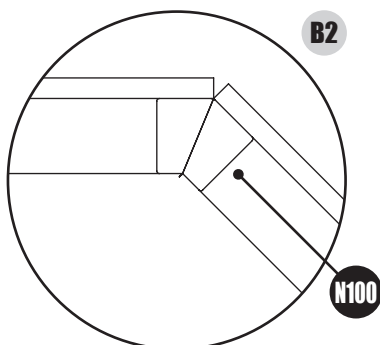
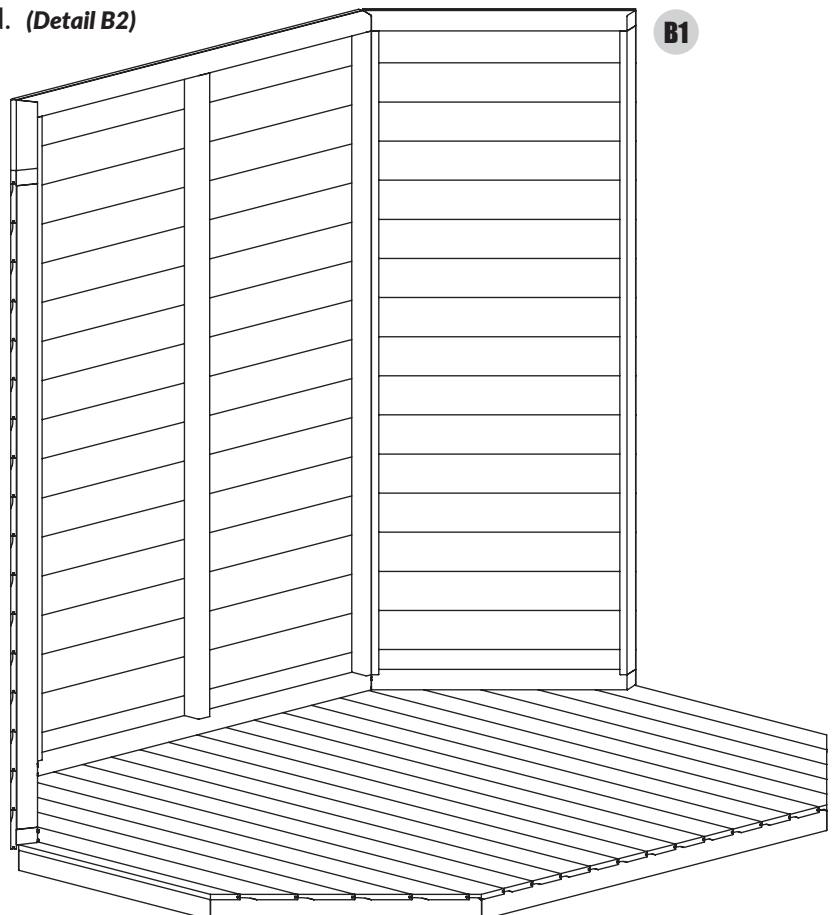

Step 3:

SECURING SIDE AND GABLE PANELS

- Check panels are square by measuring between points shown. **(Detail C1)**
- If measurements are equal, your panels are square. If not, manually adjust to suit.
NOTE: DO NOT TRIM.
- Secure panels to the floor using 2x N100 per panel. Ensure the N100 are driven through the panels and into the floor bearers. **(Detail C2)**

NOTE: PANELS HAVE BEEN REMOVED FOR CLARITY.

NOTE: CHECK THAT ALL PANELS ARE AT RIGHT ANGLES TO EACH OTHER AND THE FLOOR.

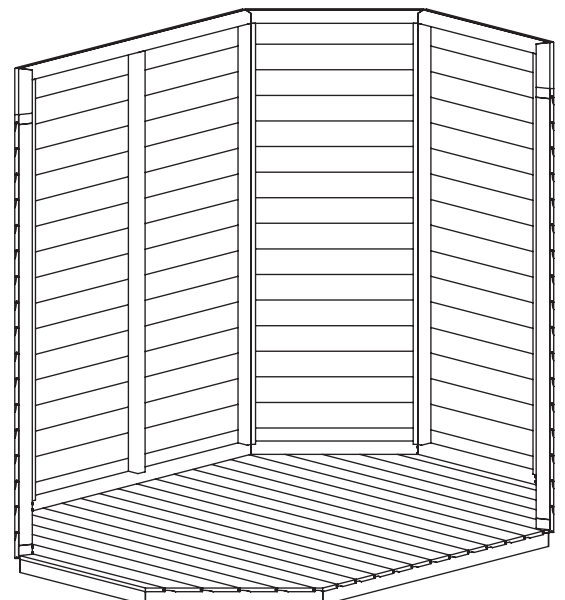
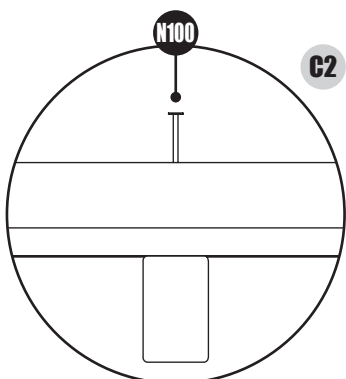
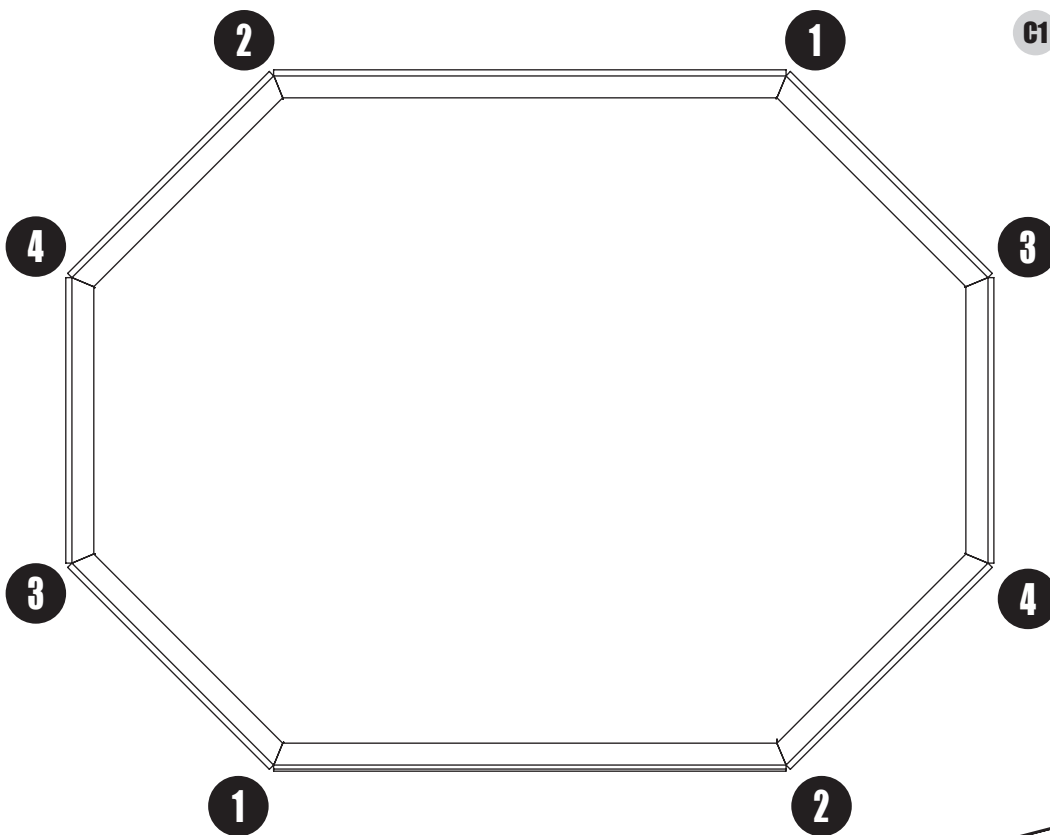

Step 4:

FIX CORNER STRIPS

- Secure the moulded corner strips at each corner of the shed with 8x N40 per corner strip.

NOTE: THESE CORNER STRIPS MAY NEED CUTTING TO SIZE

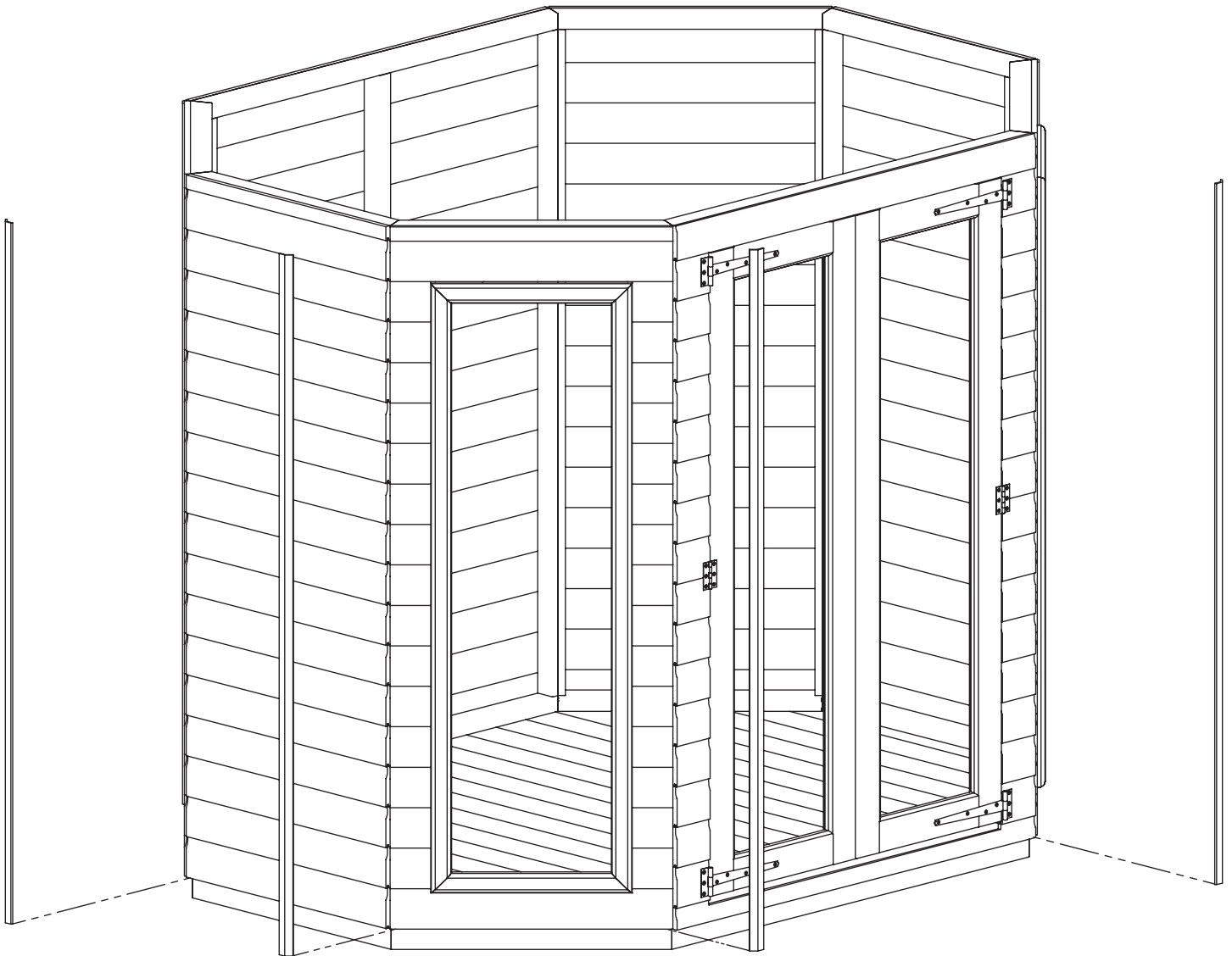

Step 5:

INSTALL FIBREGLASS ROOF

- Place fibreglass roof in position on top of walls.
- Screw 1x CB100 into top rail of each wall panel to secure fibreglass roof. **(Detail D)**
- Secure acorns to top of fibreglass roof from inside using screws provided.
 - 8x6 MODELS HAVE 2x ACORNS.
 - 6X6 MODELS HAVE 1x ACORN.

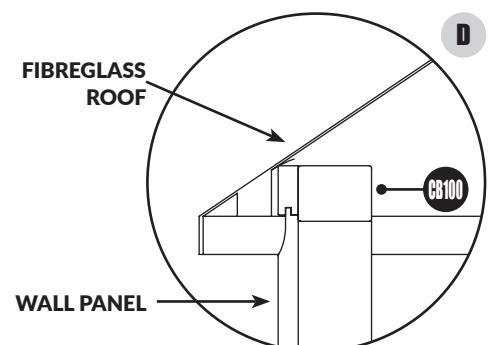
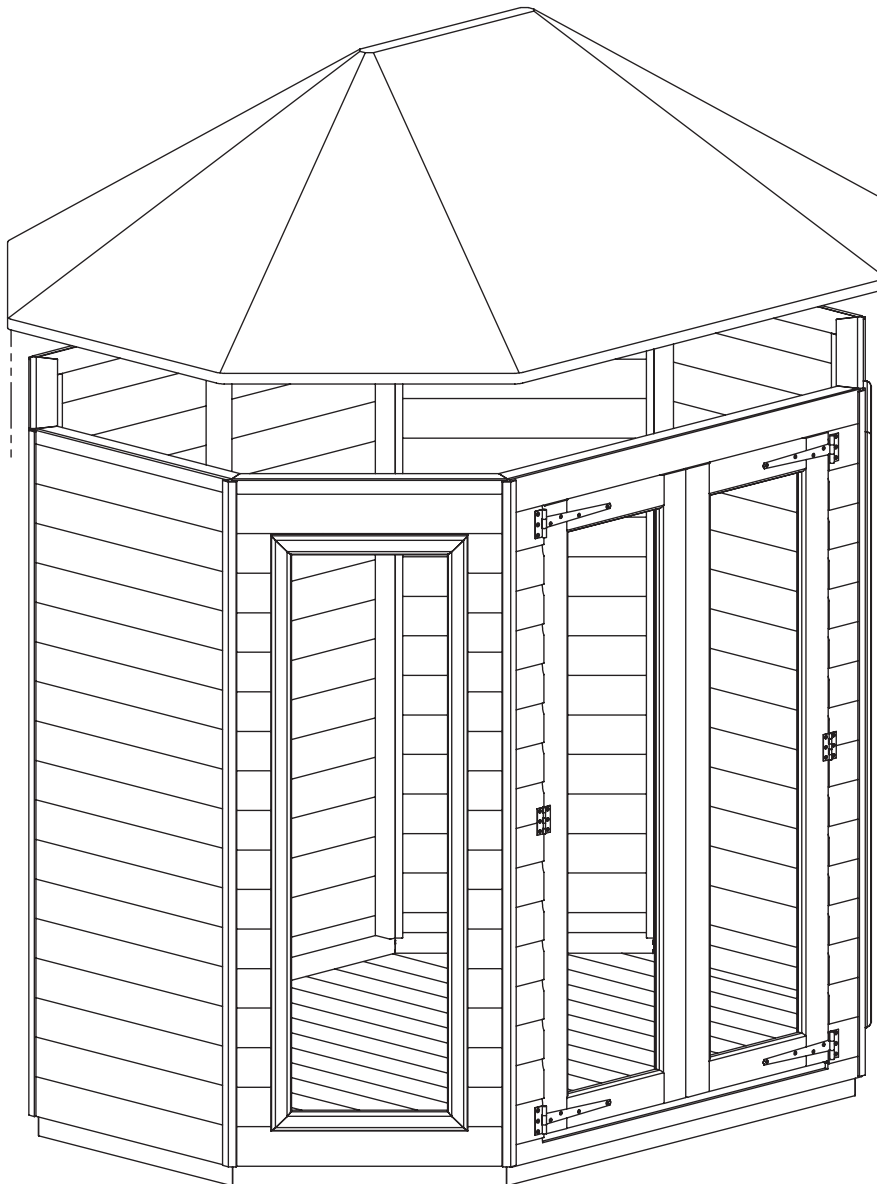

Step 6:

INSTALLING GLAZING

- Glaze windows by securing glass/styrene with PP25 supplied, from the inside. *(Detail E)*

NOTE: ALL WINDOWS MUST BE SEALED INSIDE AND OUT WITH SILICONE, PUTTY, OR ANY OTHER WATER-TIGHT SOLUTION. (NOT SUPPLIED).

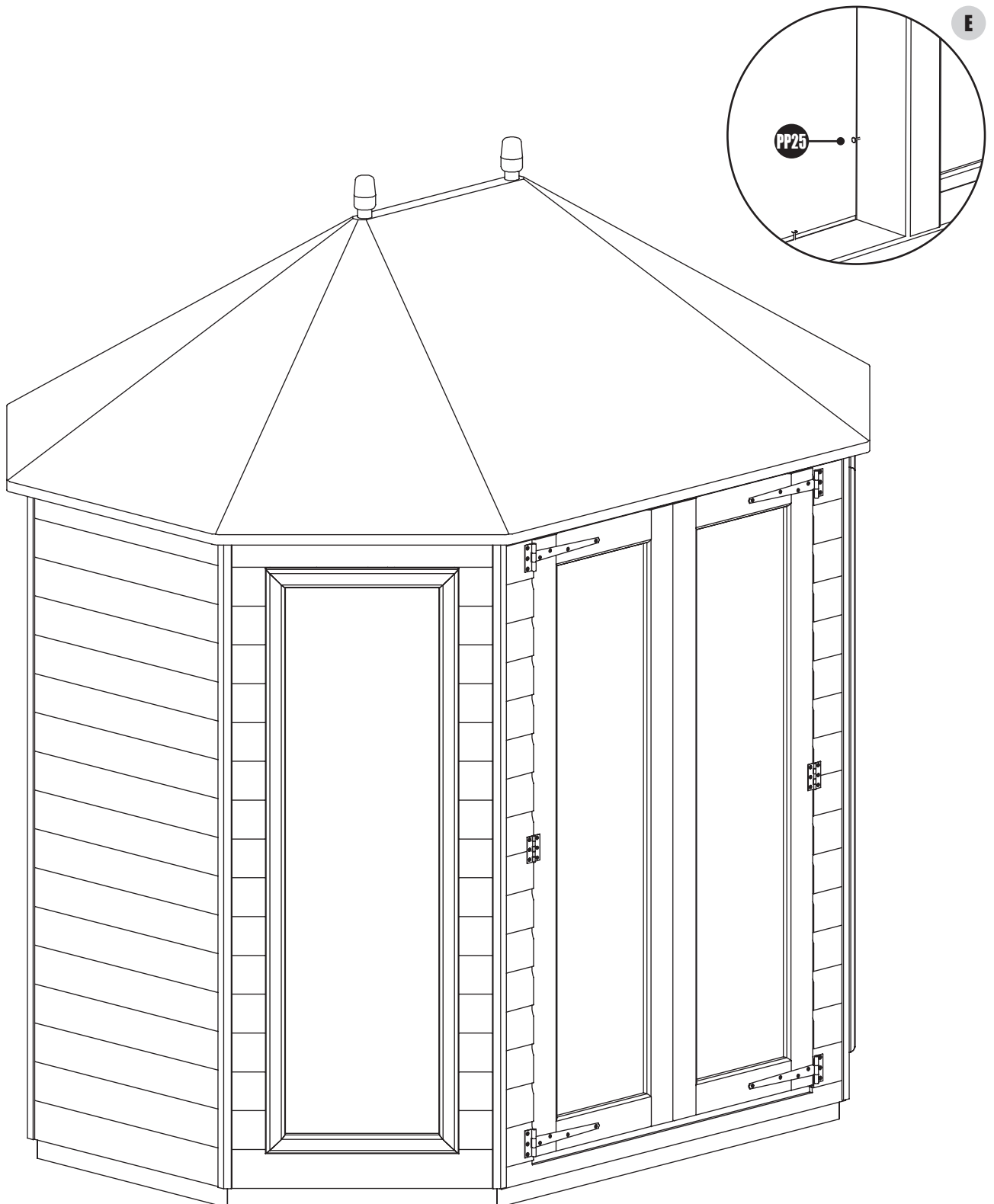

Step 7:

INSTALLING DOOR HANDLE

- Insert the spindle into one of the levers and securely fix the grub screw, ensuring enough of the spindle is free to pass through the door and to be secured in the opposing lever.
- Secure using 4x BS25 per lever plate and recheck all the fixings are secure. If the levers do not operate freely, check alignment of all components.

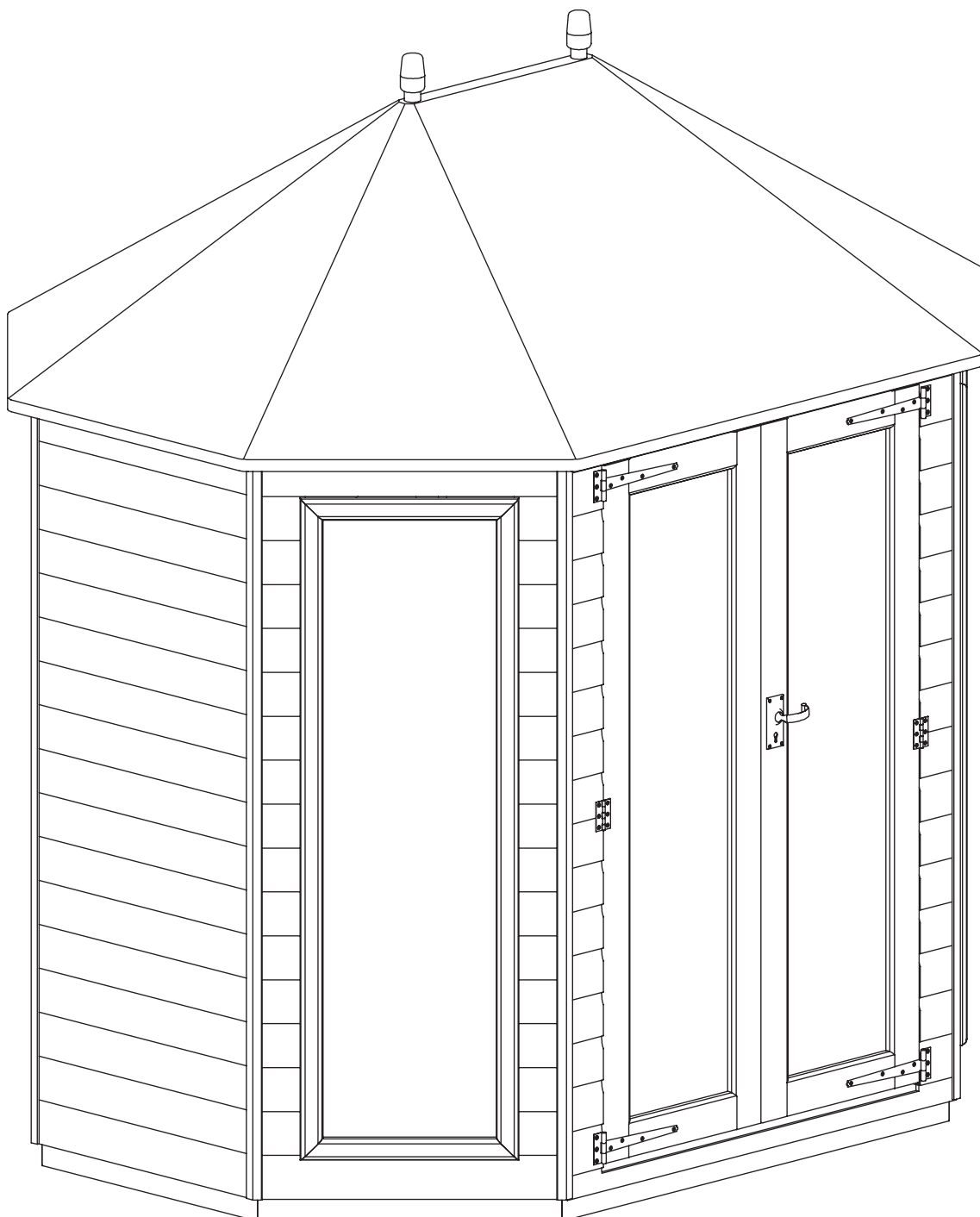



Head Office

Calverley Lane,
Rodley,
Leeds,
West Yorkshire,
LS13 1NP

Telephone: 0113 205 4189
Website: tigersheds.com
Email: customersupport@tigersheds.com



SCAN CODE!
TO SEE GENERAL ACCESSORY &
INSTALLATION VIDEO LIBRARY

