









ASSEMBLY INSTRUCTION

317-690L/M Tall rake back Chair
 317-691L/M Tall splat back Chair
 317-692L/M Tall ladderback Chair

HARDWARE LIST

A		Bolt	Ø5/16"*3-1/2"	4 PCS
B		Bolt	Ø5/16"*1-3/4"	2 PCS
C		Nut	Ø5/16"	4 PCS
D		Lock Washer	Ø5/16"	10 PCS
E		Flat Washer	Ø5/16"*19D	10 PCS
F		Allen Key	100*50*4mm	1 PC
G		Spanner Wrench	12MM	1 PC
H		Screw	Ø8*1-3/4"	6 PCS

PART LIST

1	Chair Back	1 PC
2	Seat Frame + Wood Seat	1 PC
3	Left Front Leg	1 PC
4	Right Front Leg	1 PC
5	Left Stretcher	1 PC
6	Right Stretcher	1 PC
7	Front Stretcher	1 PC
8	Wood Seat	1 PC

IMPORTANT NOTES

- . Place all wooden parts on clean and smooth surface such as rug or carpet to prevent the parts from being scratched.
- . Check to be sure that you have all parts and hardware.
- . Remove all wrapping materials, including staples and packing straps before you start to assemble.
- . Do not tighten all screws and bolts until completely assembled.
- . Keep all hardware out of the reach of children

Option 1

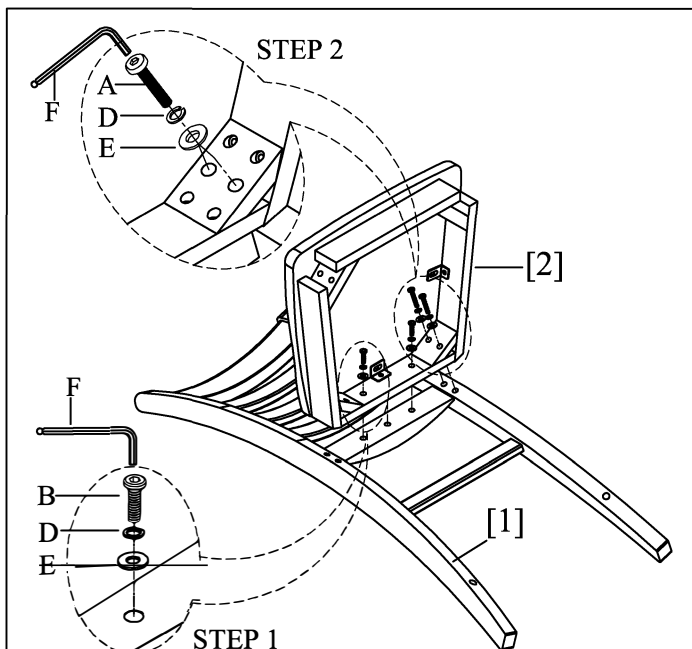

STEP 1. Place chair back (1) on a clean & padded surface then attach seat frame + wood seat (2) to the chair back using bolt (B), lock washer (D), flat washer (E), and tighten with allen key (F). Important: Do not over-tighten.
STEP 2. Attach back assembly to the seat frame + wood seat (2) using bolt (A), lock washer (D), flat washer (E), and tighten with allen key (F). Important: Do not over-tighten.

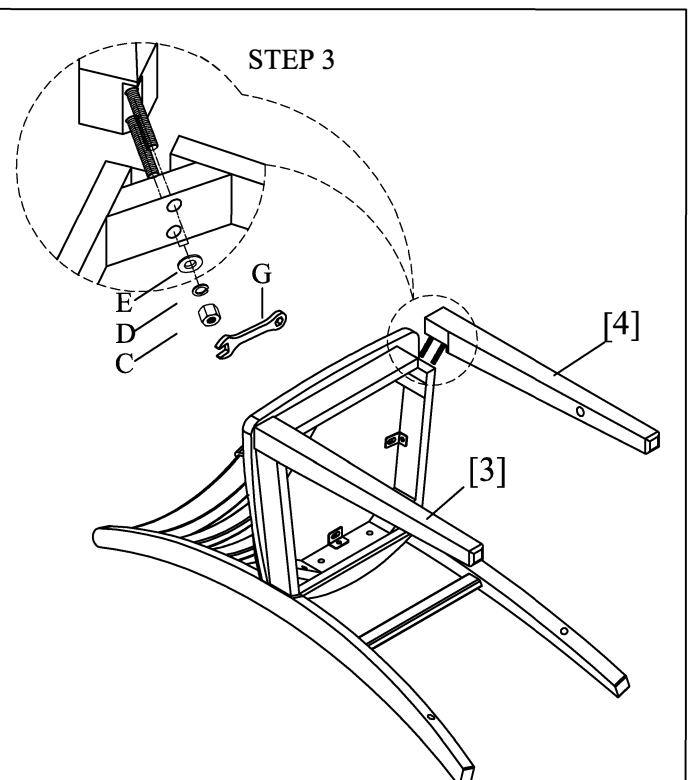

STEP 3 . Attach the left front leg (3) and right front leg (4) to the seat frame + wood seat (2) using nut (C), lock washer (D), flat washer (E), and tighten with spanner wrench (G). Important: Do not over-tighten.

ASSEMBLY INSTRUCTION

317-690L/M Tall rake back Chair
317-691L/M Tall splat back Chair
317-692L/M Tall ladderback Chair

Option 1

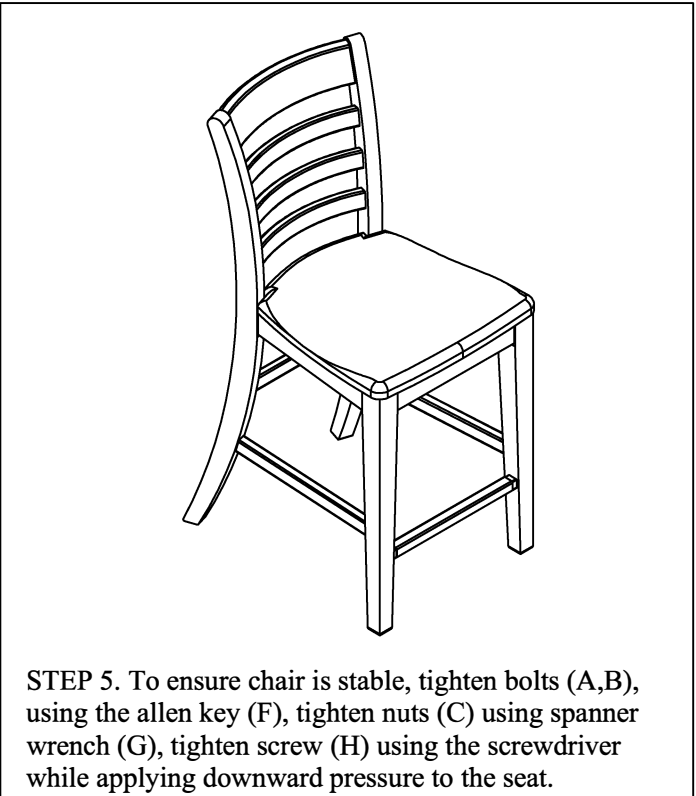
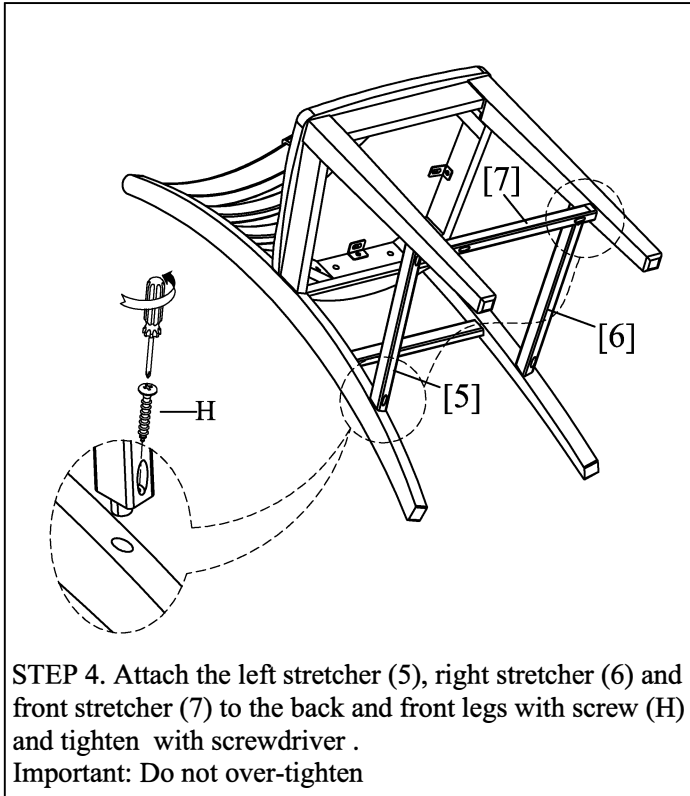

Option 2

