

HAPPINESS HAPPINESS INSTALLATION



CAUTION

Parts are placed at the bottom of the product.

- If you have any questions with the product, please contact us by:
- **Email: customerservice@zoy-living.com**
(we will reply to you within 24 hours)

Assembly Instructions



Model: CS0447AF61D

CAUTION

DO NOT use any sharp objects to open plastic wrapped components as this may result damage to product or components .

Your sofa comes packaged in one boxes. Carefully remove all of components from the packaging and set aside for assembly.

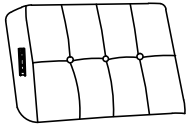
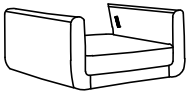
Package Contents

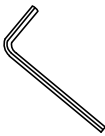
BOX 1 CS0447AF61D				
	A*1	B*1	C*4	D*12
				
	E*1			

1 ACCENT CHAIR ASSEMBLY - BODY SETUP

STEP1 :

Remove **hardware** and **wooden feet (C&D&E)** from the **bottom (B)** pocket of the sofa

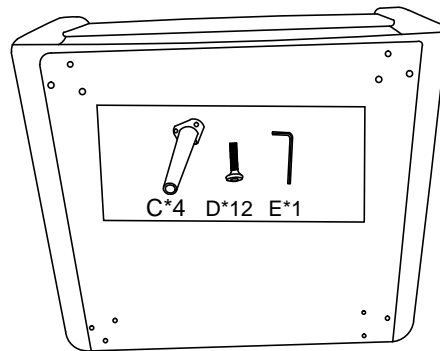

STEP 2:

Install **hardware (D&E)** onto the sofa through **wooden feet (C)**

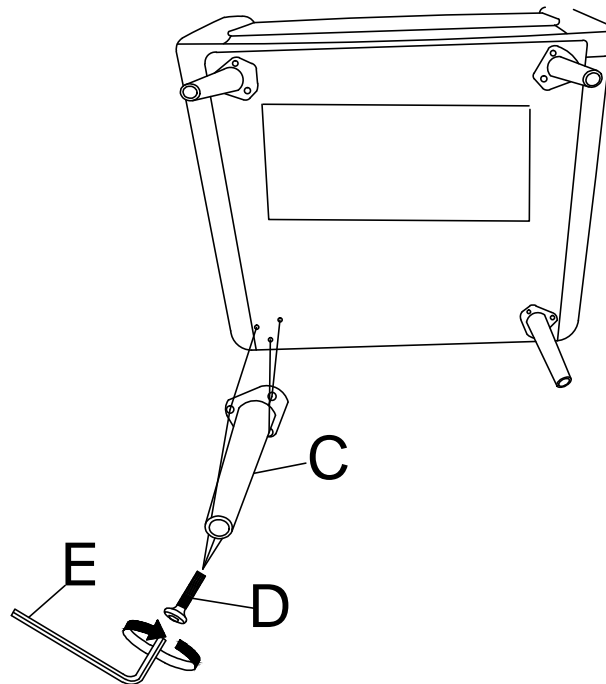

2 ACCENT CHAIR ASSEMBLY - BODY SETUP

STEP 3:

Install the **seat back (A)** onto the **seat body (B)** using a metal slider.

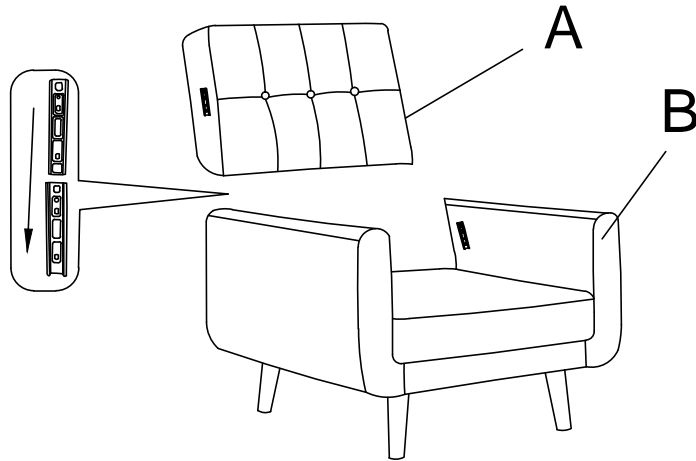

Assembly completed

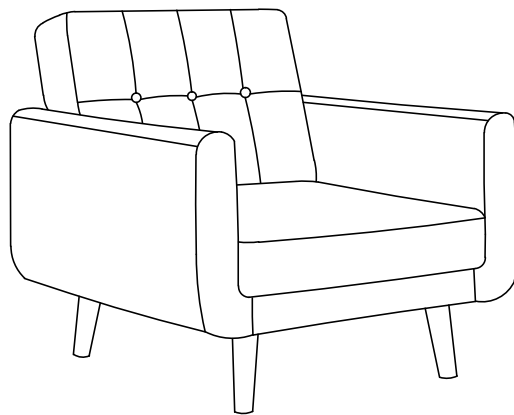

3 ACCENT CHAIR ASSEMBLY - BODY SETUP

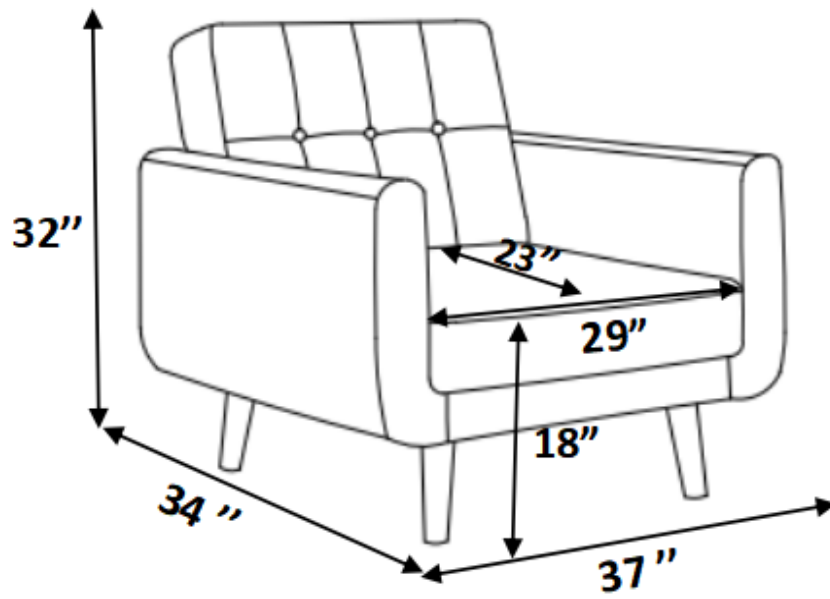

CS0447AF61D

⚠️ WARNINGS

1. Please check if the components of the chair are all included and can be used normally.
2. Assemble all components according to the instruction correctly before you connect the chair to the power.
3. Please DO NOT sit on the armrests or footrest to eliminate the risk of tipping over.
4. If the chair is damaged or doesn't match the website description, please send clear pictures of the product and label of the carton to our service team for further help.
5. If the chair doesn't work, you may try the following measures for self-checking firstly:
 - a) check if all the cables are connected;
 - b) check if the light of transformer is on.

If the chair still doesn't work, please feed the information back to our customer service in time and we will help you solve the matter as soon as possible.

6. If you have any questions about our products, please contact us by:

Email: customerservice@zoy-living.com (we will respond to your inquiry within 24 hours)

