

Invisia™ Toilet Roll Holder

with Support Rail

INVISIA
LIVE BEAUTIFULLY

Technical Data Sheet

Product Specification

The product shall be a combination toilet roll holder and grab rail. The product shall be mounted to the wall using A discreet 0.125"/0.318cm thick plate and an additional contact point. The grab rail portion of the product shall be 1.25"/3.2 cm in diameter. The product shall be suitable for use in a wet environment. The product shall have a weight capacity in excess of 500lbs / 227kg. Product shall comply with ADA Guidelines, specifying the structural strength of grab bars, tubs and shower seats. The grab rail shall be Invisia Collection model INV-WTRH-____ (see table below for appropriate product code).

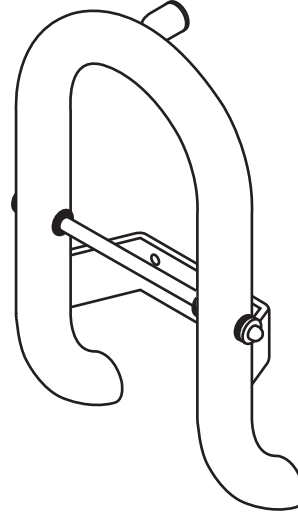

Key Features

- Elegant Design with Integrated Support
- Solid Construction and Discreet Mounting
- Suitable For Use in a Wet Environment
- 500lbs / 227kg Weight Capacity*

Codes and Standards

- ADA 609.2 Cross Section
- ADA 609.3 Spacing
- ADA 609.8 Structural Strength



Specified Model

MODEL	AA - FINISH	MATERIAL
INV-WTRH-AA	CP (Polished Chrome) BS (Brushed Stainless) BLK (Matte Black) ORB (Oil Rubbed Bronze)	#304 Stainless Steel

Invisia™ Toilet Roll Holder

with Support Rail

INVISIA
LIVE BEAUTIFULLY

Technical Data Sheet

Product Dimensions

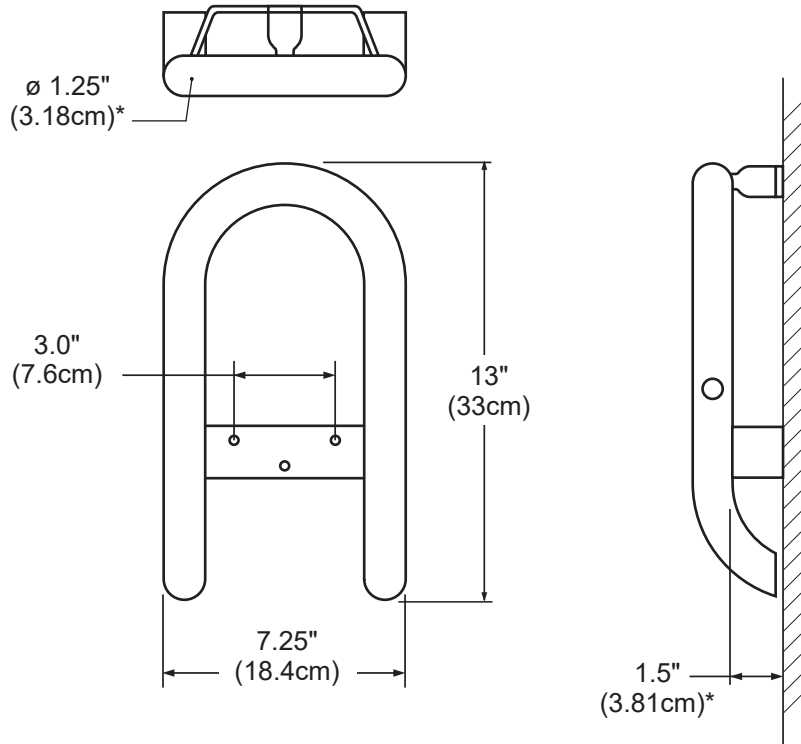

*ADA Compliant

Shipping Dimensions

Model	Height (H)	Width (W)	Depth (D)	Weight
WTRH	3.5" / 9cm	22.5" / 35.5cm	7.75" / 22cm	3.5lbs / 1.6kg

