

# TV STAND

**Assembly Instructions - Please keep for future reference**

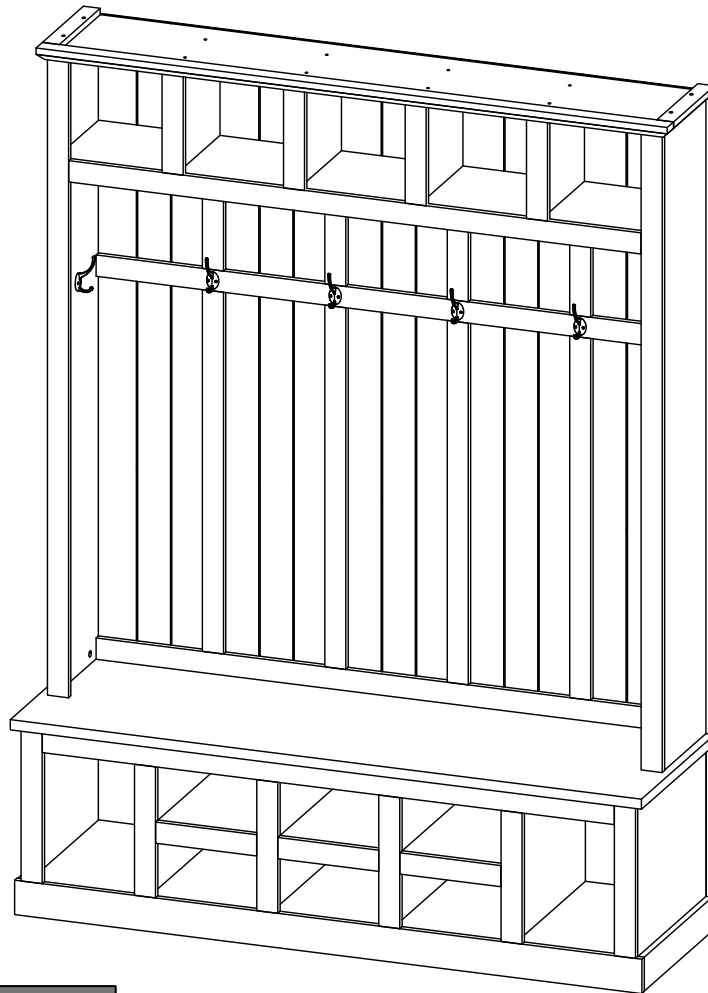

## **Dimensions**

**Width-59.1inch**

**Depth-18.11inch**

**Height-78.74inch**

**Important – Please read these instructions fully before starting assembly**



## Safety and Care Advice

**Important – Please read these instructions fully before starting assembly**

- Check you have all the components and tools listed on the following pages.
- Remove all fittings from the plastic bags and separate them into their groups.
- Keep children and animals away from the work area, small parts could choke if swallowed.
- Make sure you have enough space to layout the parts before starting.

- During assembly do not stand or put weight on the product, this could cause damage.
- Assemble the item as close to its final position (in the same room) as possible.
- Assemble on a soft level surface to avoid damaging the unit or your floor.
- Parts of the assembly will be easier with 2 people.



- To reduce the likelihood of damaging your product please ensure that your power drill is set on a low torque setting.

### Care and maintenance

- Only clean using a damp cloth and mild detergent, do not use bleach or abrasive cleaners.
- From time to time check that there are no loose screws on this unit.
- This product should not be discarded with household waste. Take to your local authority waste disposal centre.

### Handy Hints

- Assemble all parts and bolts loosely during assembly, only once the product is complete should you fully tighten the bolts
- Regularly check and ensure That all bolts and fittings are tightened properly.

**WARNING**  
**In order to help prevent overturning – please follow these instructions**











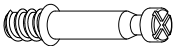
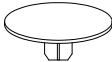
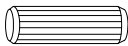

To help prevent product toppling over please follow the below steps:-

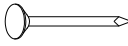
- Use the anti tip stap or wall fixing method provided (if applicable)
- Do not allow children to climb or hang on the furniture
- Do not open more than one drawer at a time
- Do not place heavy items in the top drawers
- Do not place heavy items on top of the furniture, unless the furniture has been designed for this purpose

# Components - Fittings

Please check you have all the panels listed below

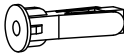
Note: The quantities below are the correct amount to complete the assembly. In some cases more fittings may be supplied than are required.

<p><b>A1</b></p>  <p>Cam lock x 78 + 2</p>	<p><b>A2</b></p>  <p>Cam bolt x 78 + 2</p>	<p><b>A3</b></p>  <p>Cam cap x 74 + 2</p>	<p><b>B</b></p>  <p>8*30mm Dowel x 100 + 2</p>
<p><b>C</b></p>  <p>6*50mm Screw x 28 + 2</p>	<p><b>D</b></p>  <p>Allen key x 1</p>	<p><b>E</b></p>  <p>3.5*16mm Screw x 16 + 2</p>	<p><b>F</b></p>  <p>4*16mm Screw x 100 + 2</p>
<p><b>G</b></p>  <p>16mm Nail x 33</p>	<p><b>H</b></p>  <p>Nail leg x 8</p>	<p><b>I</b></p>  <p>Spring door support x 16 + 2</p>	<p><b>J</b></p>  <p>L bracket x 2</p>
<p><b>K</b></p>  <p>Hook x 6</p>	<p><b>L1</b></p>  <p>4*12mm Screw x 2</p>	<p><b>L2</b></p>  <p>4*50mm Screw x 2</p>	<p><b>L3</b></p>  <p>Wall plug x 2</p>
<p><b>L4</b></p>  <p>PVC strip x 2</p>			

## Tools required

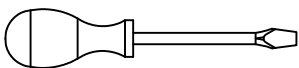

Philips screwdriver  
(medium & large)

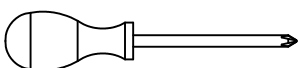

# Using Camlocks

## Step 1

Connect the male camlock as directed in the assembly instructions using a screwdriver.

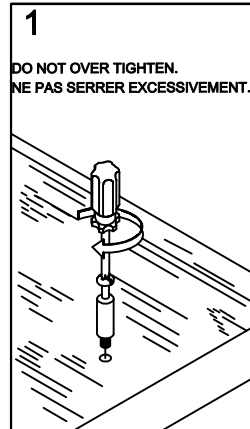

## Step 2

Push the male camlock into the entry hole.

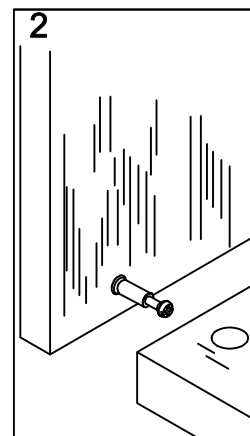

## Step 3

Insert the female camlock as shown in the instruction.

Note: ensure that the arrow on the top of the camlock points towards the entry hole for the male camlock.

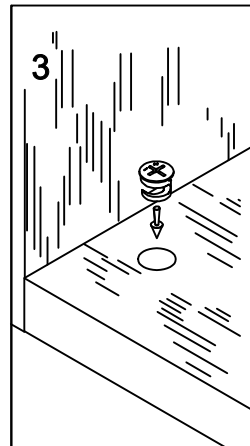

## Step 4

Turn the female camlock clockwise with a screwdriver.

You should feel a click when the camlock is locked in place.

The joint is now secure.

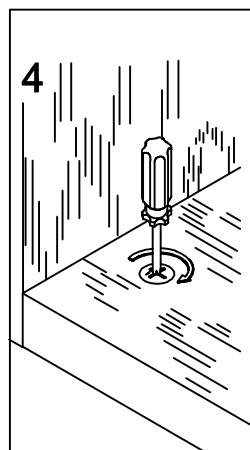





# Components - Parts



Please check you have all the panels listed below.  
Please note that there are 2 boxes of this product.

<p>① Top Panel (Up) 1500*298*30 1 PC</p>	<p>⑤ Center Panel (Up) 263*234*15 4 PCS</p>	<p>⑥ Back Bone (Up) 1428*50*15 1 PC</p>
<p>⑦ Back Bone (Down) 1428*50*15 1 PC</p>	<p>⑧ Front Bone Long (Up) 1360*50*15 1 PC</p>	<p>⑨ Side Bone (L&amp;R) 1500*50*15 2 PCS</p>
<p>⑩ Center Bone (Up) 234*50*15 4 PCS</p>	<p>⑪ Back Bone Long 853*50*15 4 PCS</p>	<p>⑫ Back Bone Short 298*50*15 4 PCS</p>
<p>⑮ Top Panel (Center) 1500*460*24 1 PC</p>	<p>⑯ Bottom Panel (Down) 1428*430*15 1 PC</p>	<p>⑳ Front Bone Long (Down) 1359*50*15 1 PC</p>

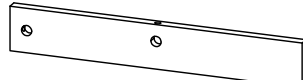
# Components - Parts

<p>24</p> 	<p>25</p> 	<p>26</p> 
<p><b>Down Side Bone (L&amp;R)</b> 359*50*15 2 PCS</p>	<p><b>Down Center Bone</b> 309*50*15 4 PCS</p>	<p><b>Down Middle Bone</b> 240*50*15 3 PCS</p>
<p>27</p> 	<p>28</p> 	
<p><b>Leg Panel (Center)</b> 1491*81*15 1 PC</p>	<p><b>Center Leg</b> 430*65*15 1 PC</p>	

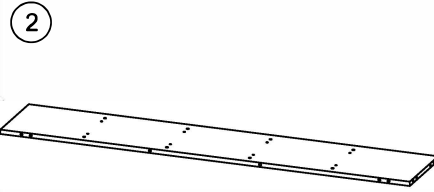
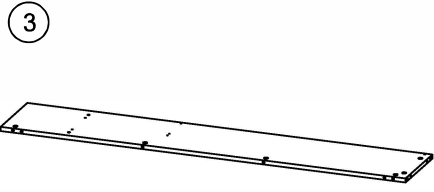
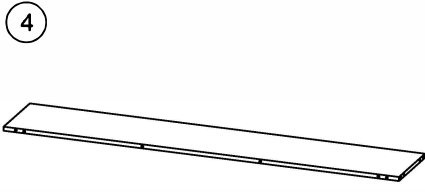
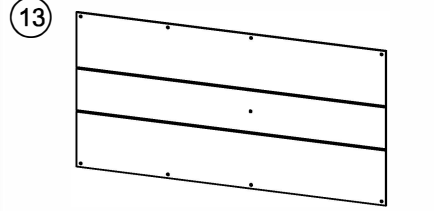
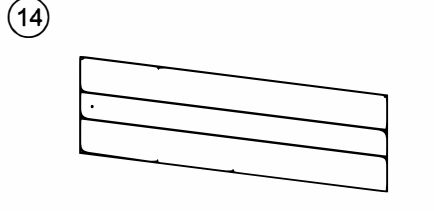
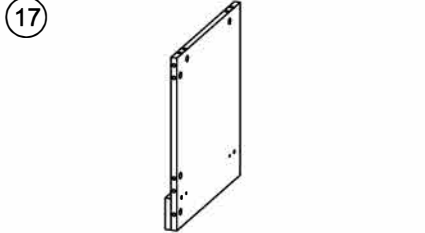
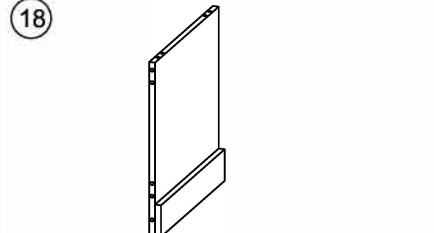
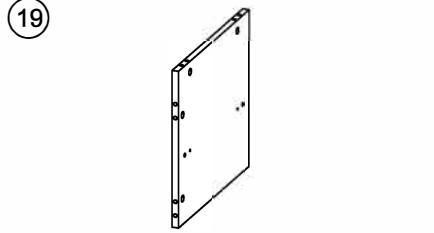
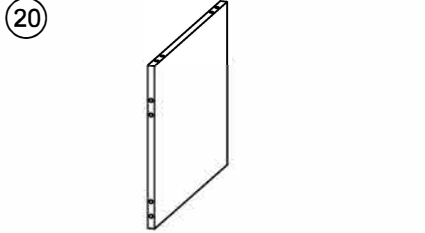
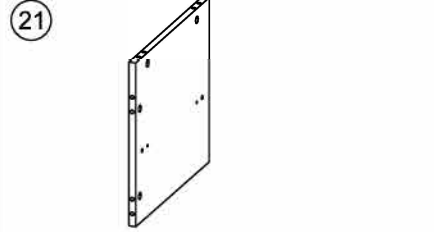
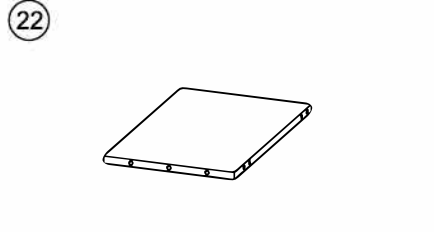
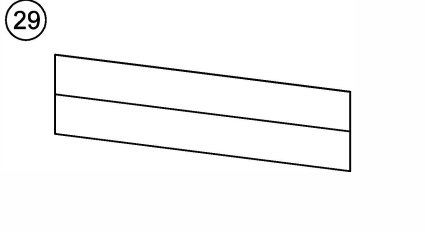
# Components - Parts

		
<p>Bottom Panel (Up) 1428*263*15 1 PC</p>	<p>Side Panel (L) 1500*263*15 1 PC</p>	<p>Side Panel (R) 1500*263*15 1 PC</p>
		
<p>Back Panel (Up) 587*291*2.5 5 PCS</p>	<p>Back Panel (Center) 940*291*2.5 5 PCS</p>	<p>Down Side Panel (L) 440*430*30 1 PC</p>
		
<p>Down Side Panel (R) 440*430*30 1 PC</p>	<p>Down Center Panel (L) 430*360*15 1 PC</p>	<p>Down Center Panel (R) 430*360*15 1 PC</p>
		
<p>Down Center Panel 430*360*15 2 PCS</p>	<p>Middle Panel 430*275*15 3 PCS</p>	<p>Back Panel (Down) 1458*194*2.5 1 PC</p>
		
<p>Hardware Pack 1 PCK</p>		

# Assembly Instructions

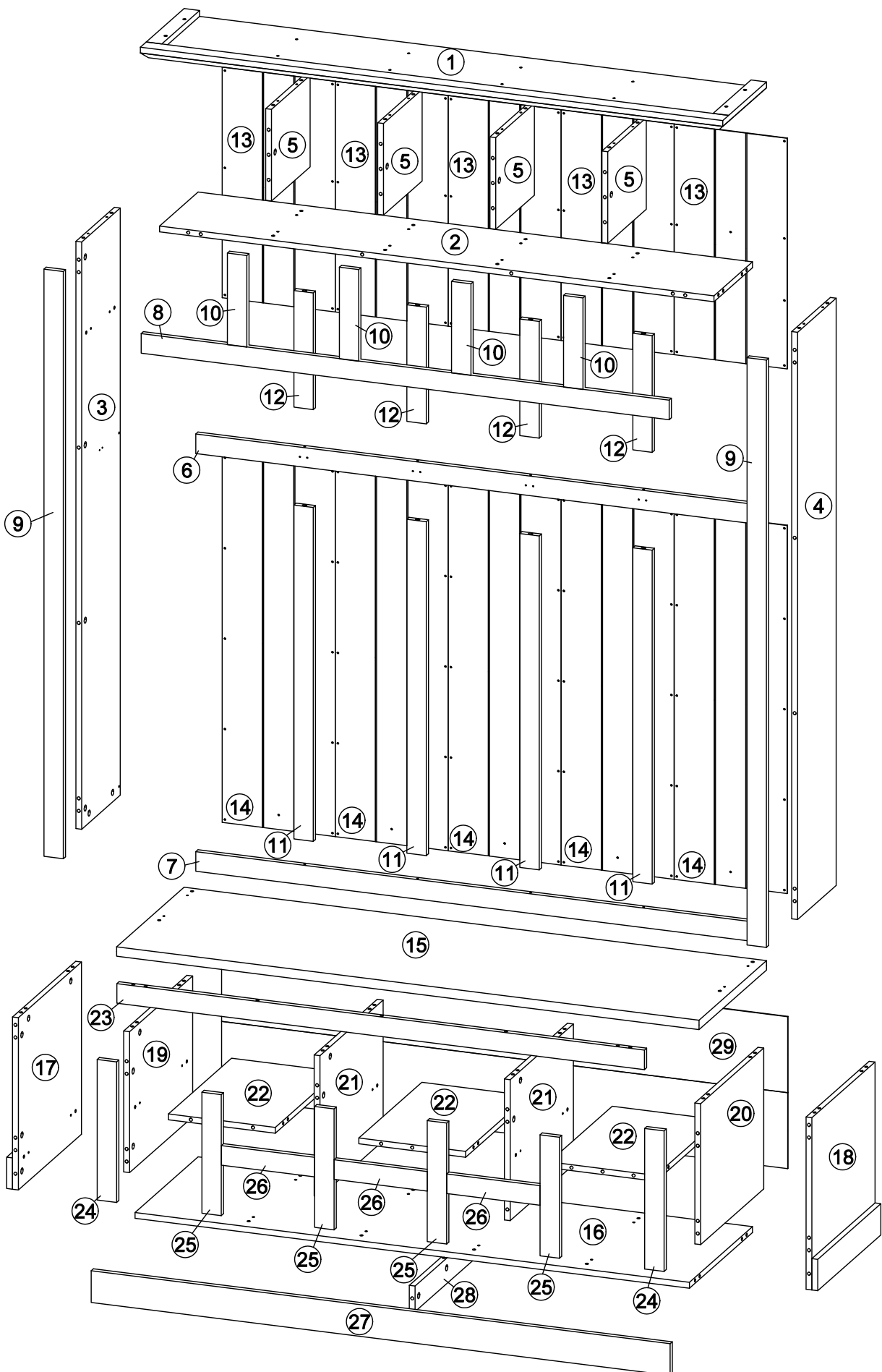

STEP 1

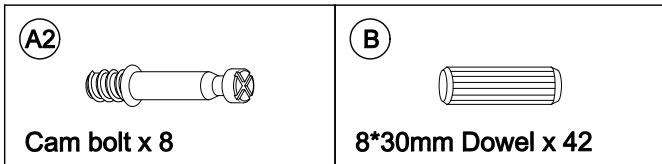
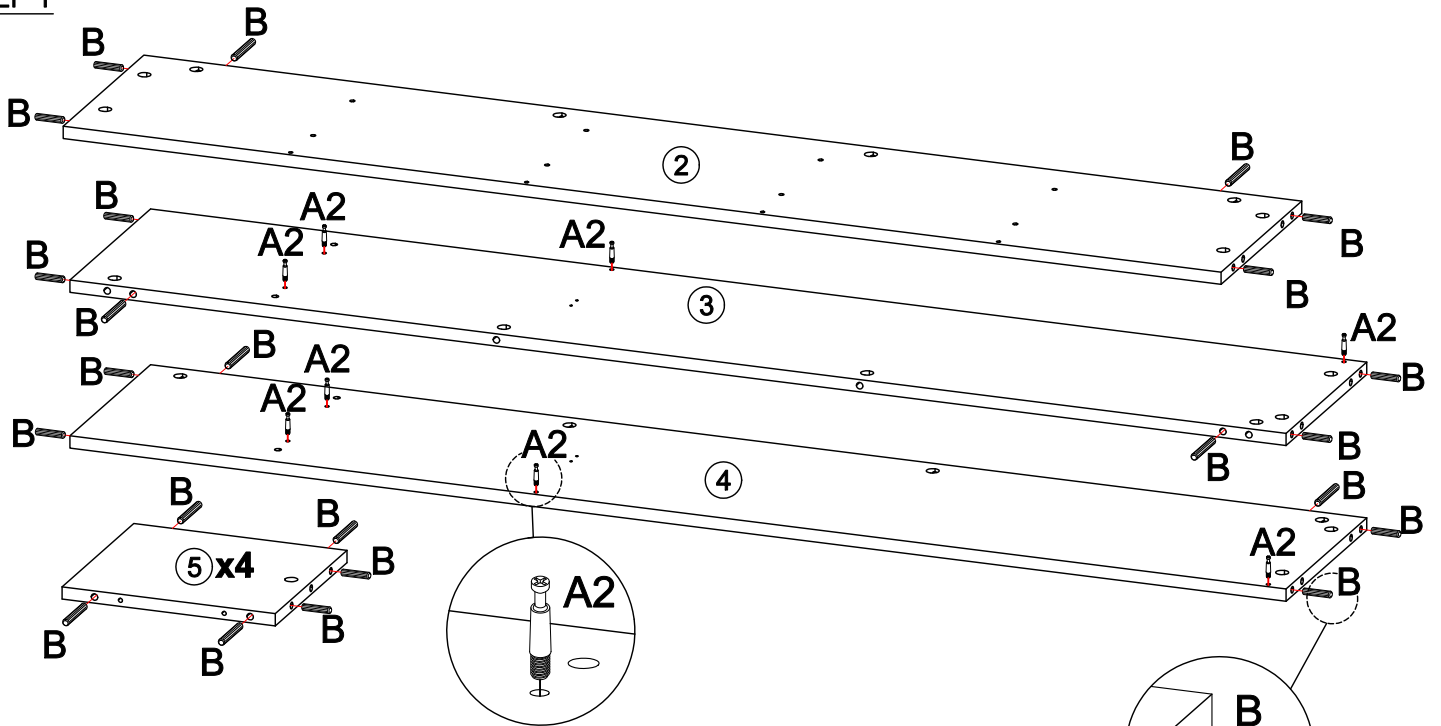

STEP 2

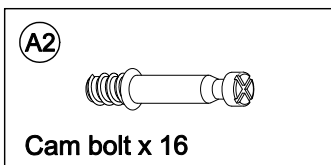
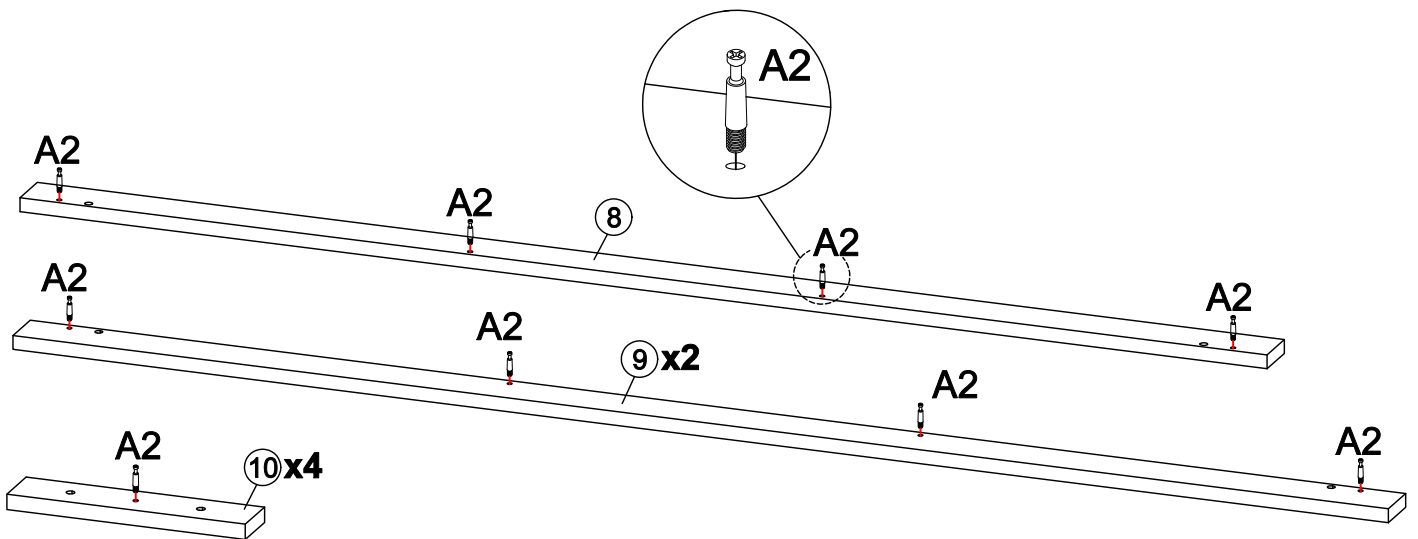

STEP 3

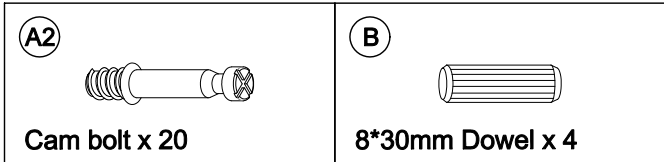
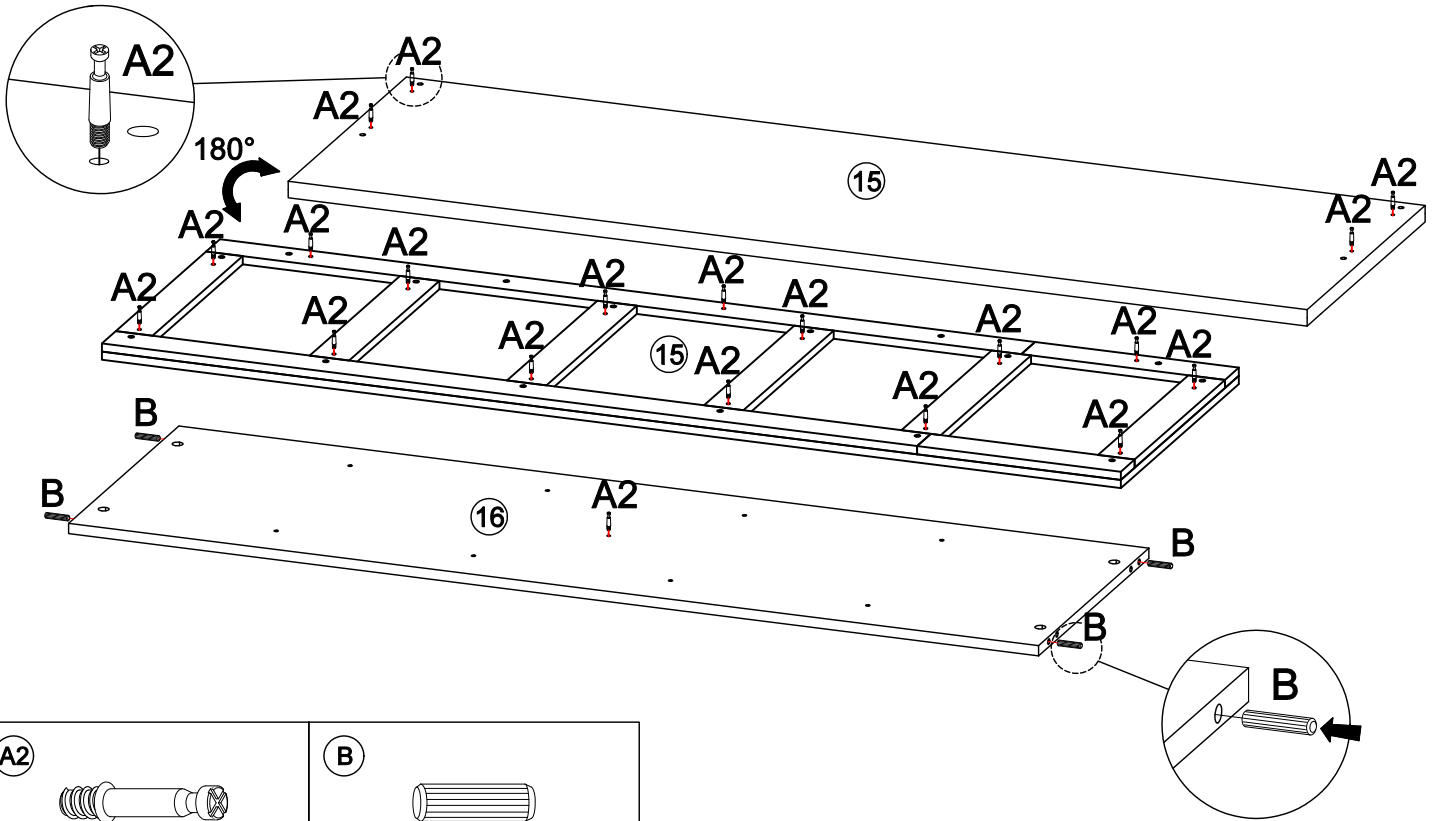

STEP 4

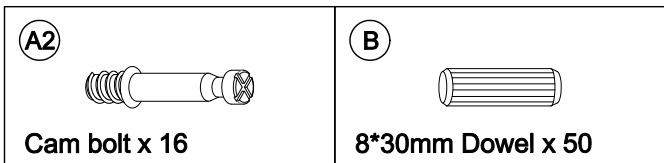
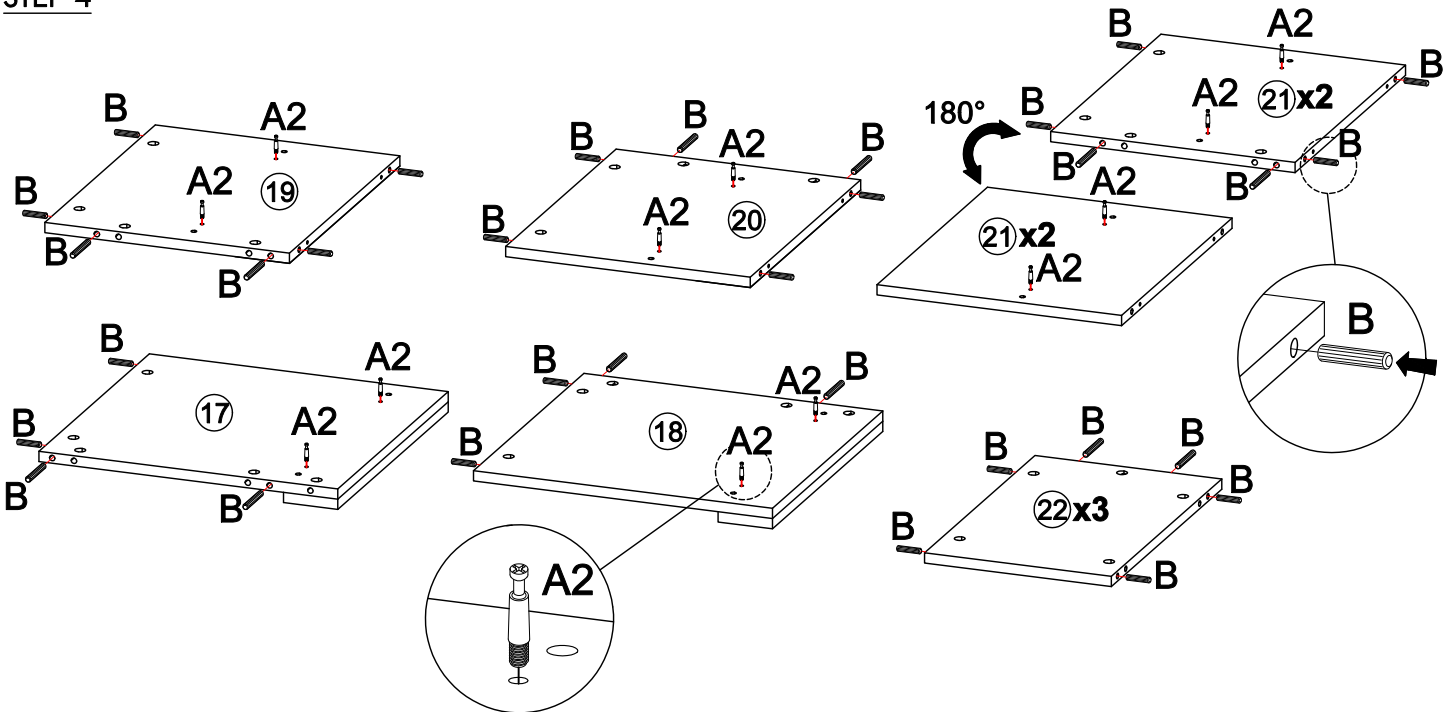

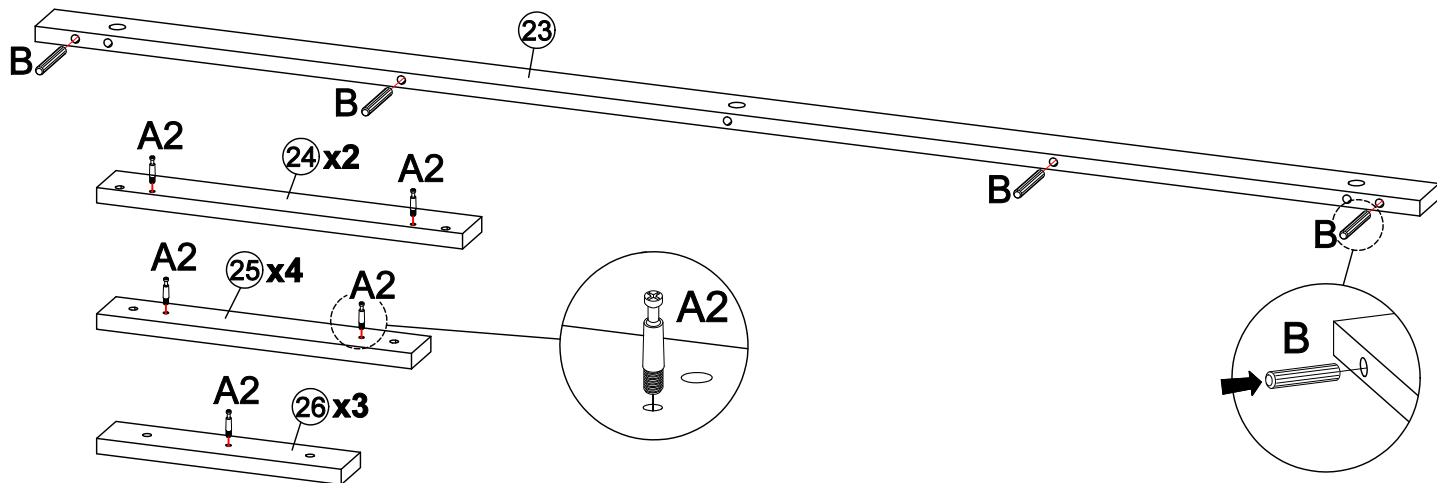

**STEP 5**

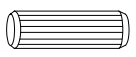

<p><b>A2</b></p>  <p>Cam bolt x 15</p>	<p><b>B</b></p>  <p>8*30mm Dowel x 4</p>
--	--

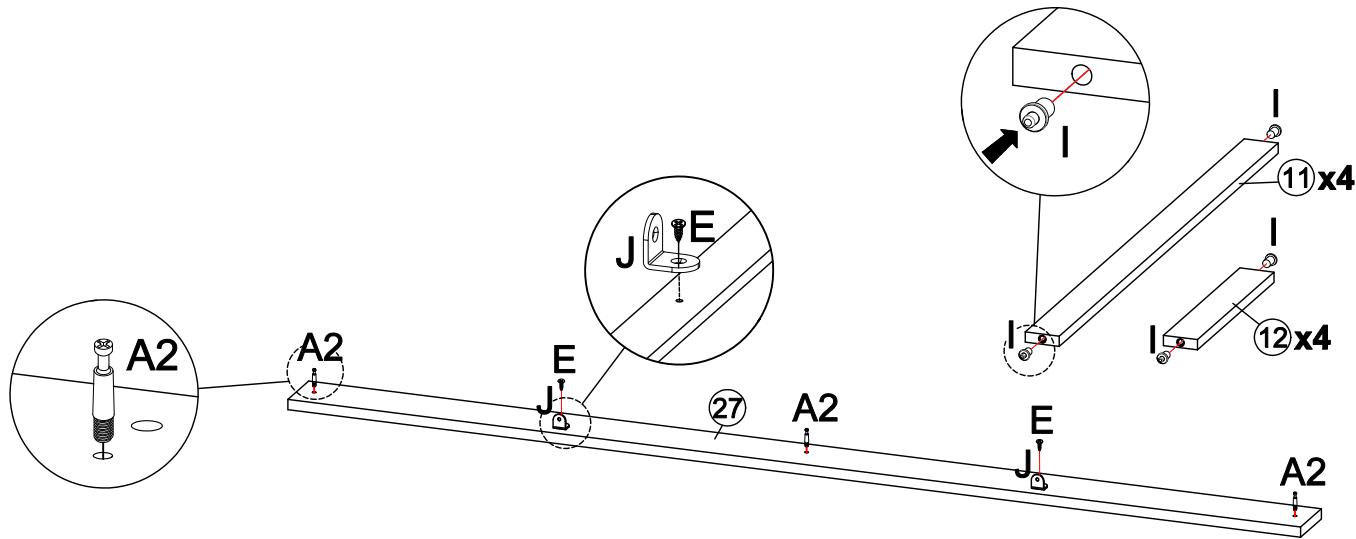
**STEP 6**

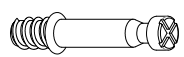

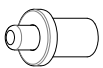
<p><b>A2</b></p>  <p>Cam bolt x 3</p>	<p><b>E</b></p>  <p>3.5*16mm Screw 2</p>	<p><b>J</b></p>  <p>L bracket x 2</p>	<p><b>I</b></p>  <p>Spring door support x 16</p>
--	---	--	---

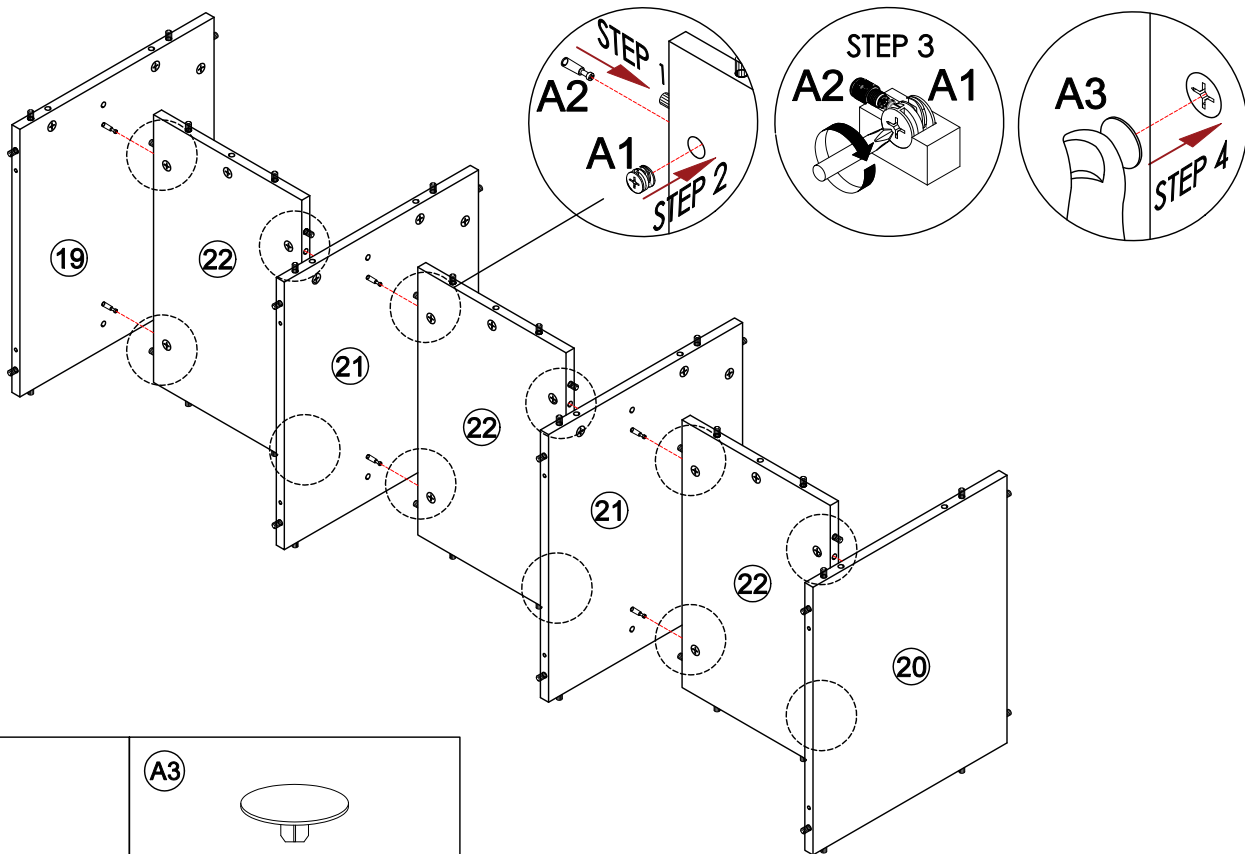

**STEP 7**

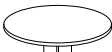

<p><b>A1</b></p>  <p>Cam lock x 12</p>	<p><b>A3</b></p>  <p>Cam cap x 12</p>
--	---

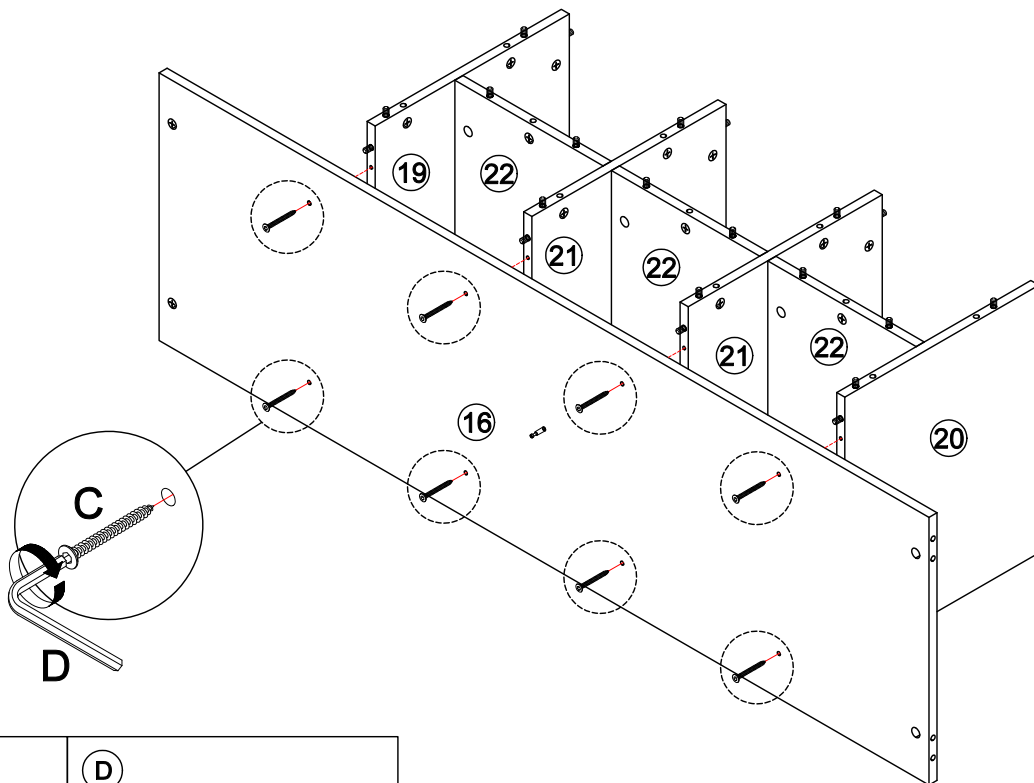
**STEP 8**

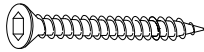

<p><b>C</b></p>  <p>6*50mm Screw x 8</p>	<p><b>D</b></p>  <p>Allen key x 1</p>
---	--

STEP 9

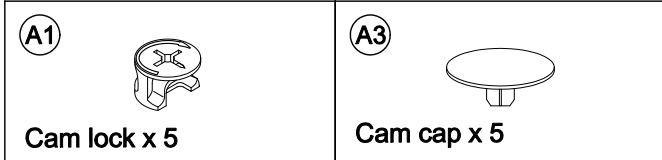
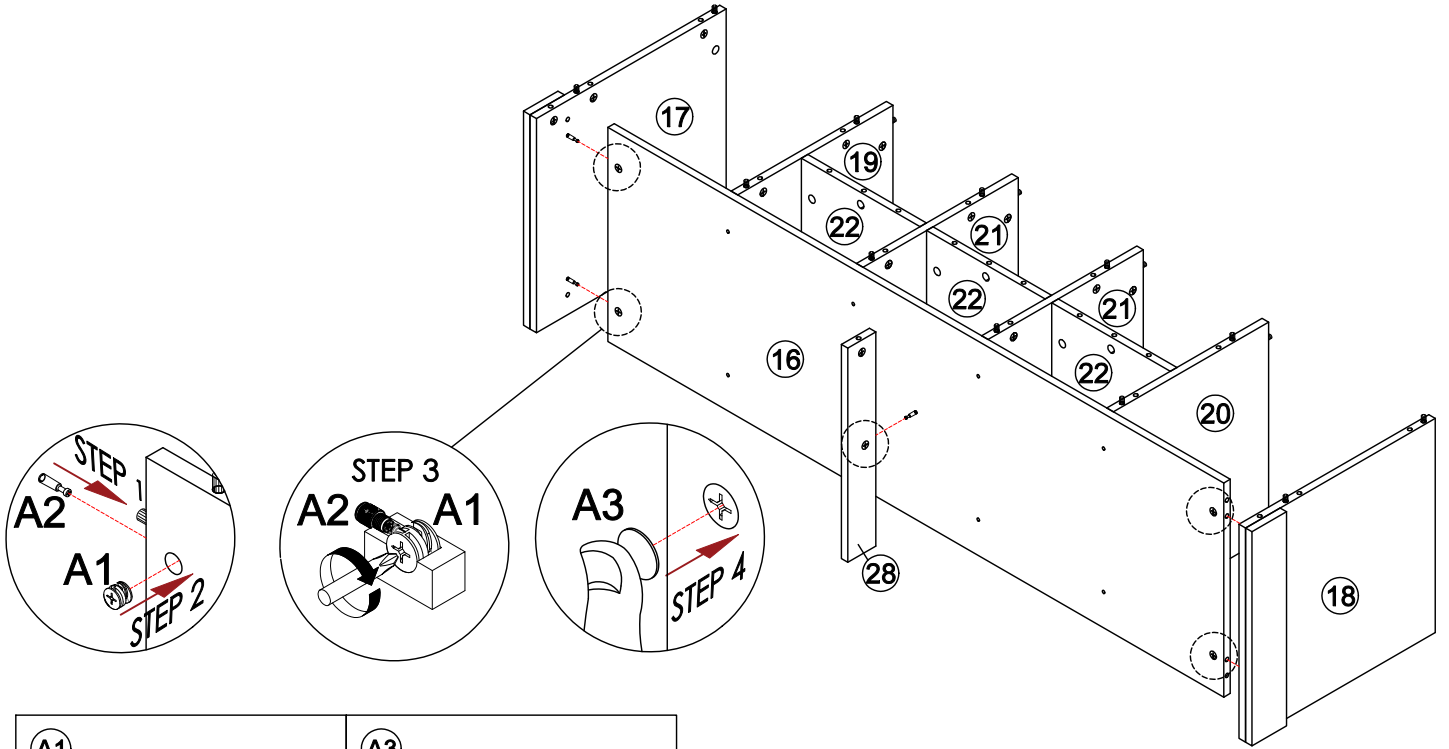

STEP 10

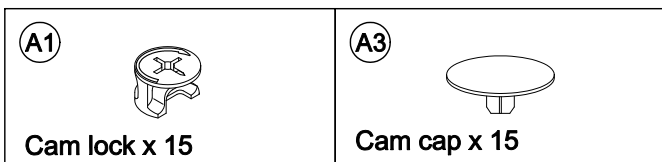
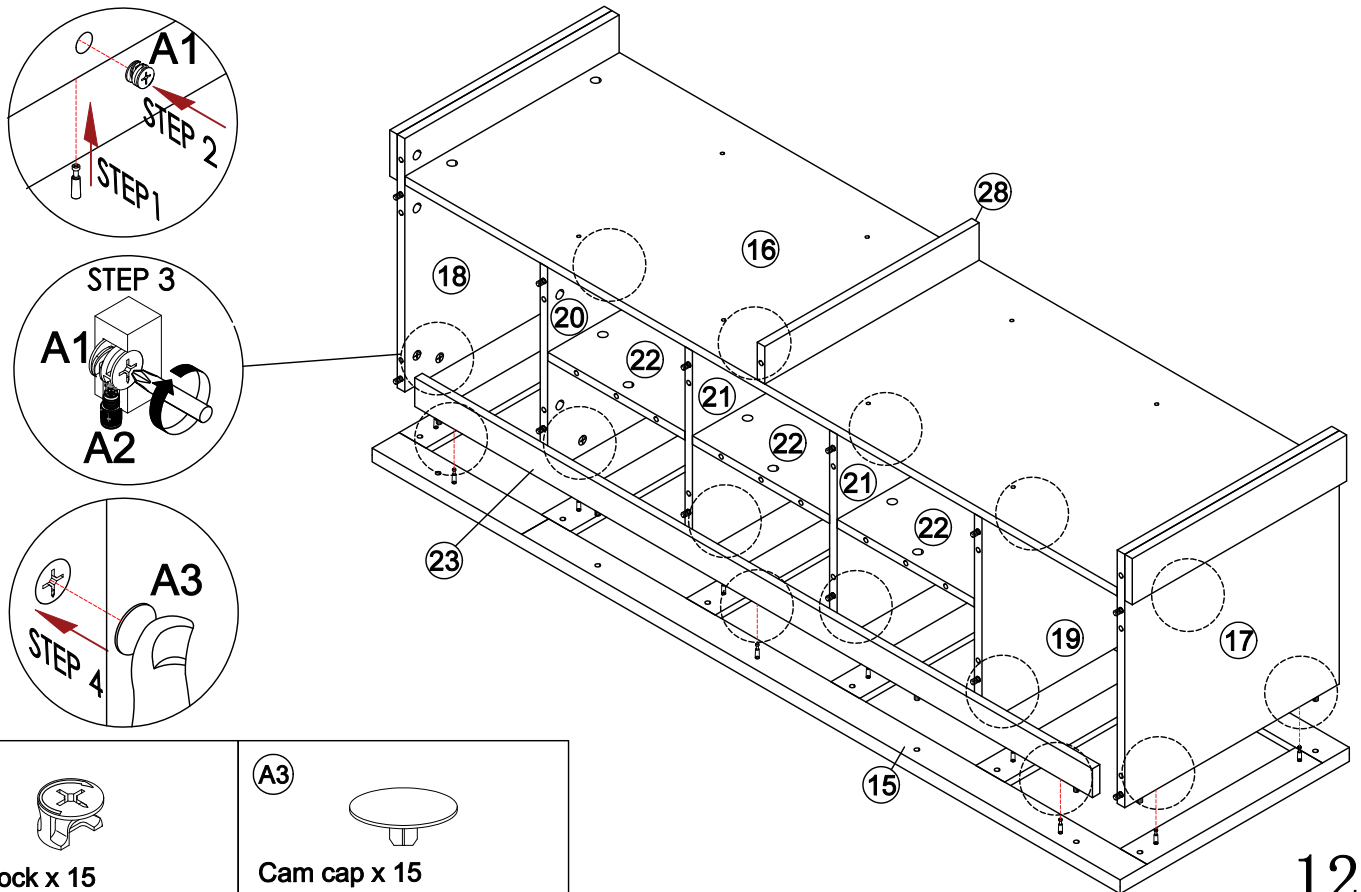

STEP 11

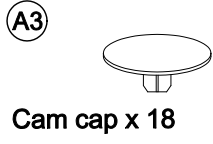
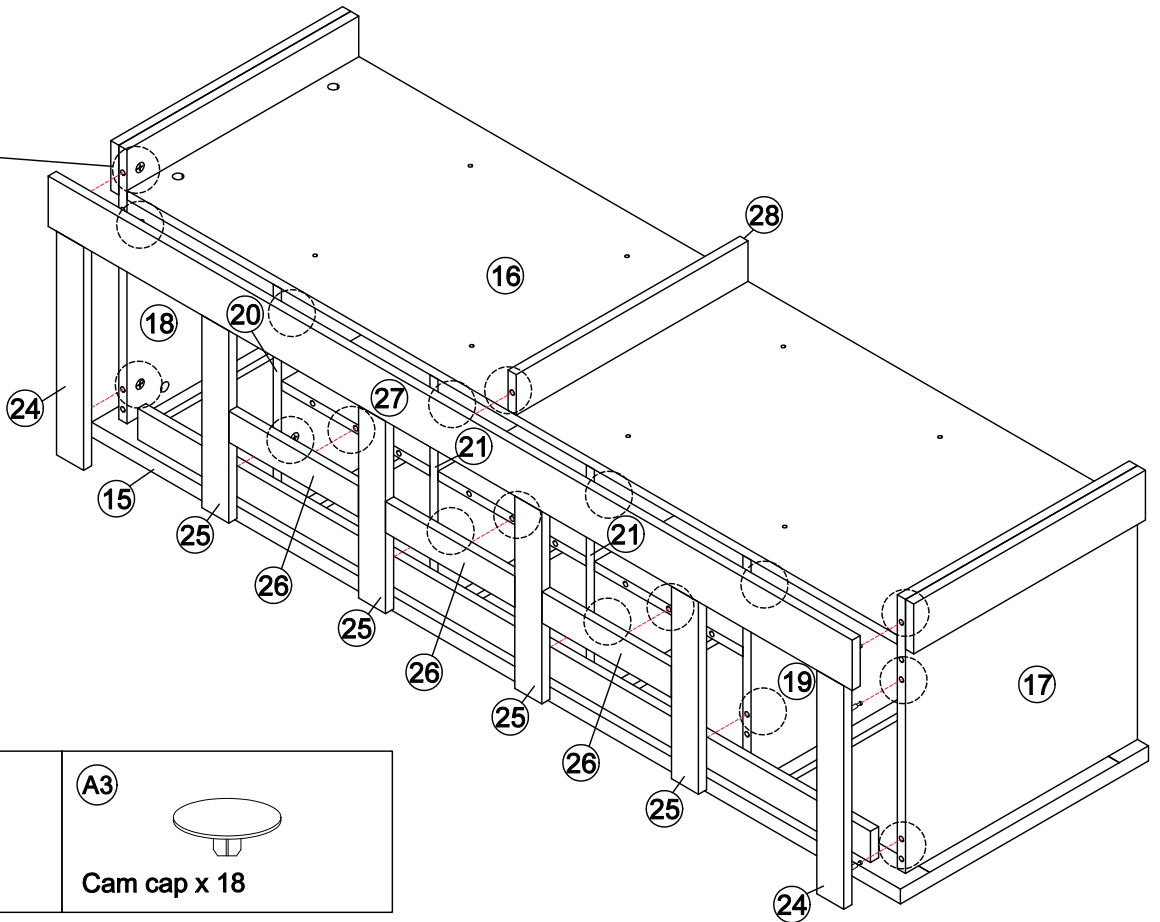
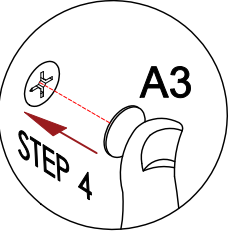
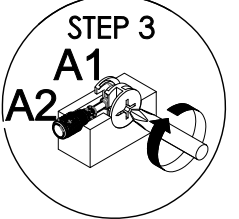
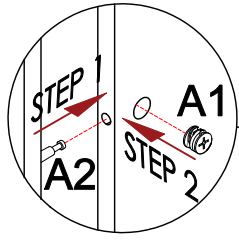

STEP 12

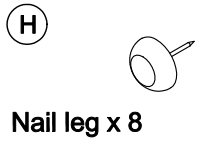
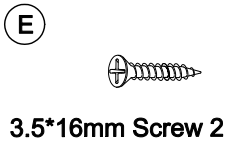
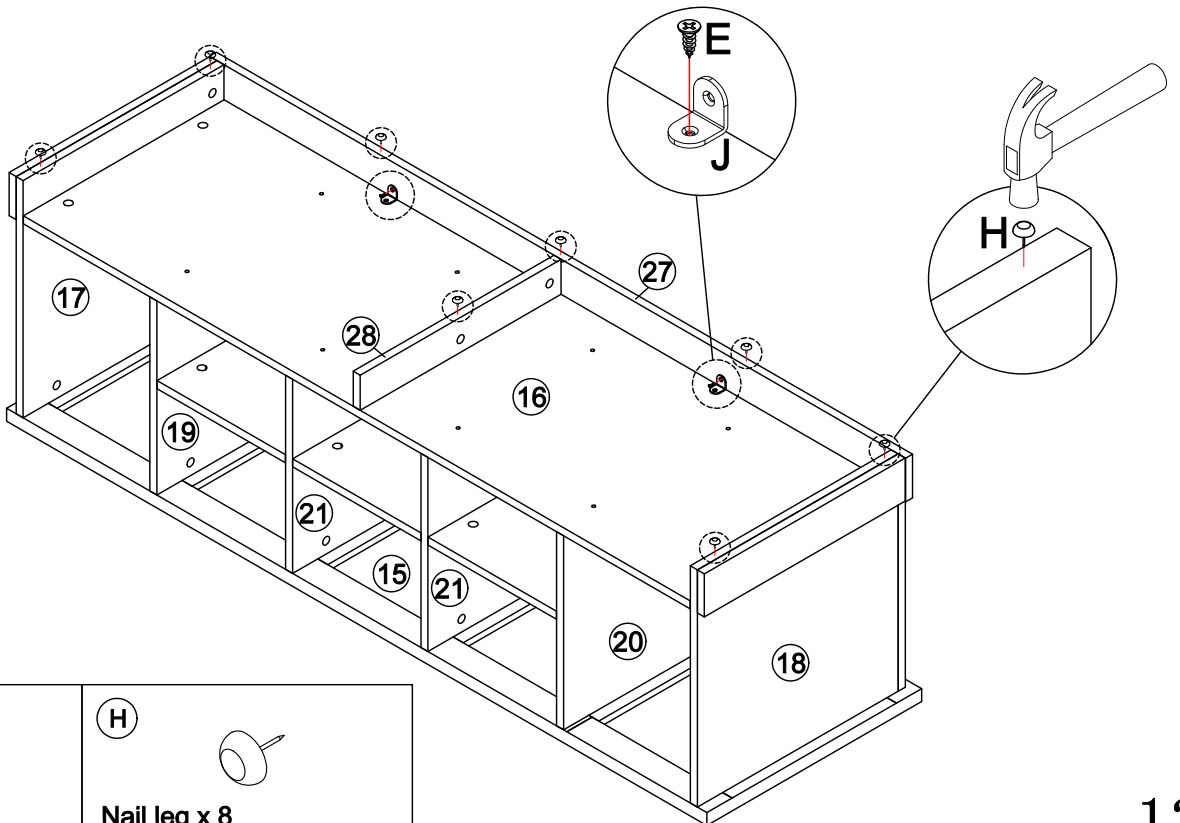

**STEP 13**

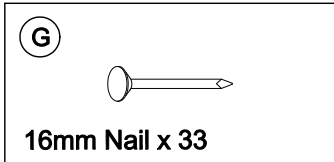
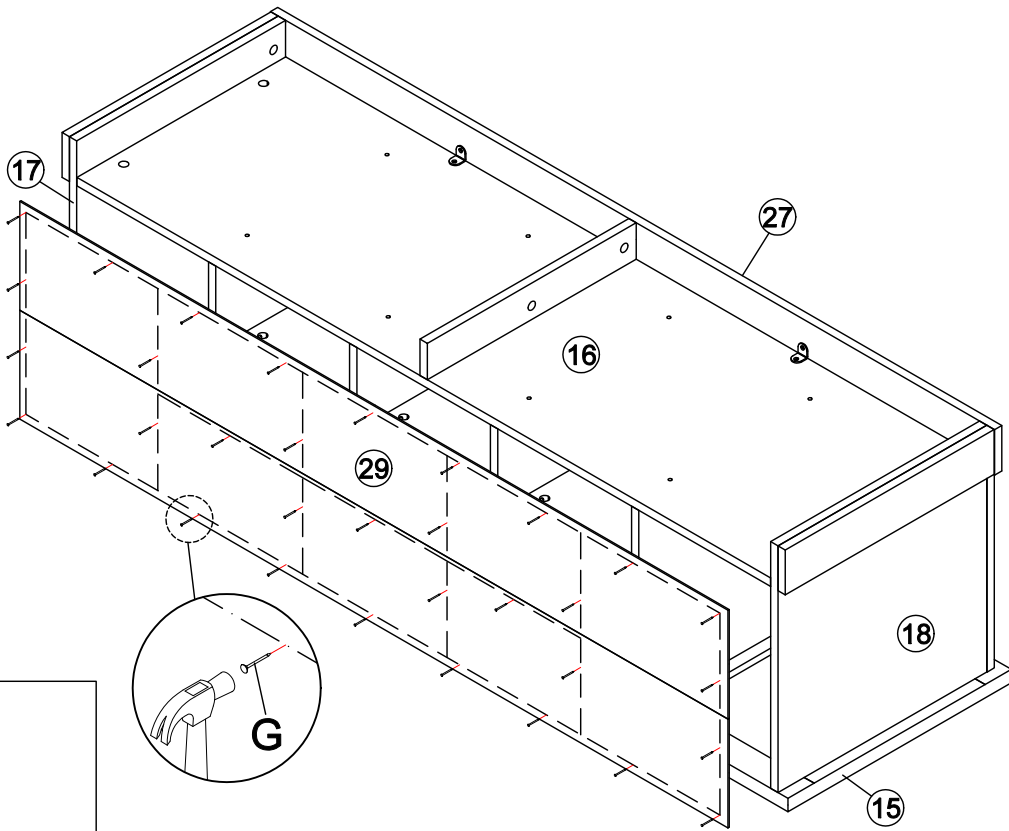

**STEP 14**

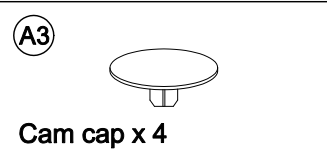
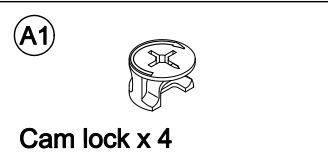
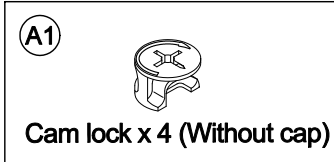
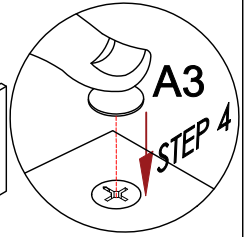
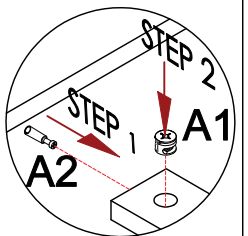
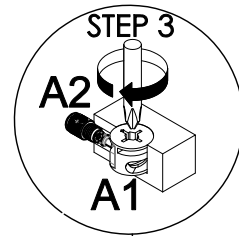
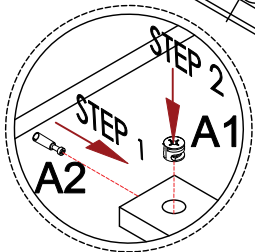
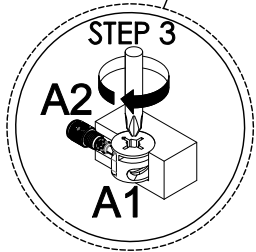
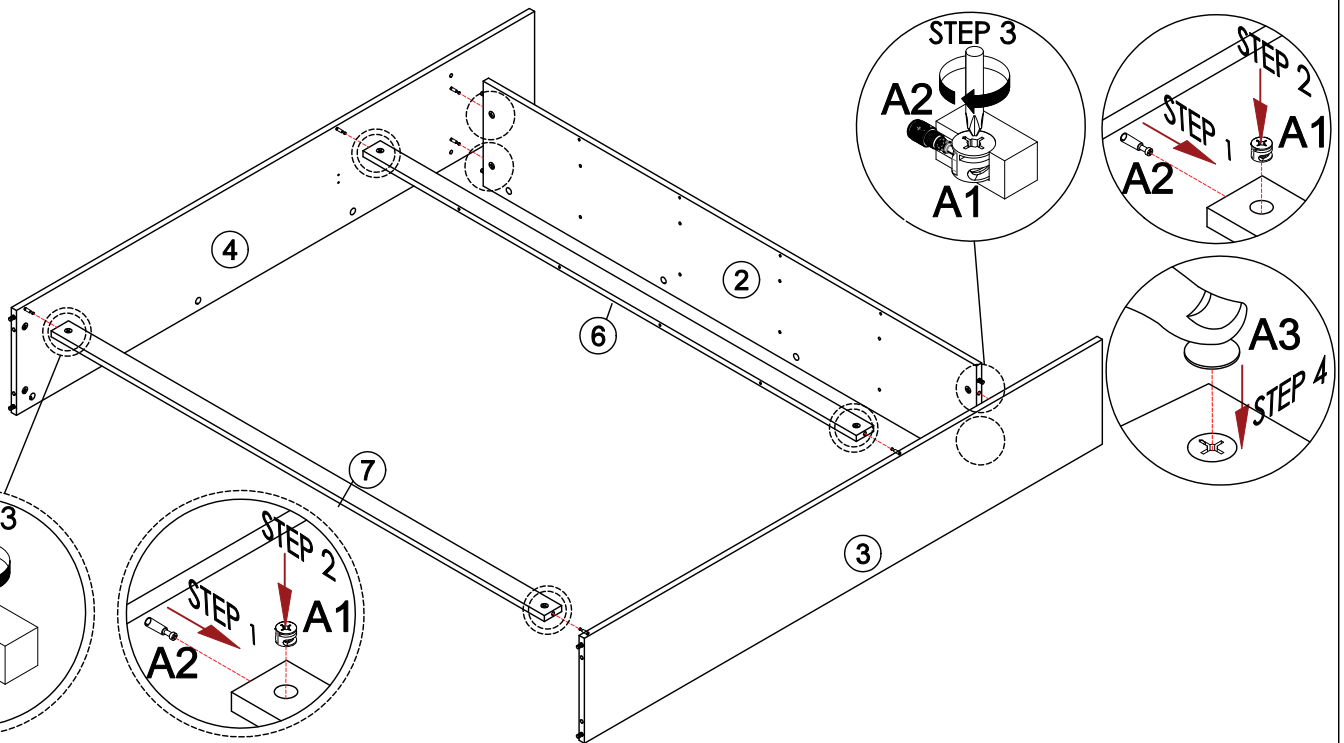

STEP 15

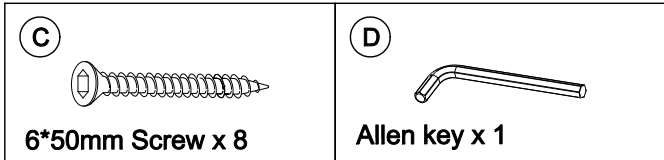
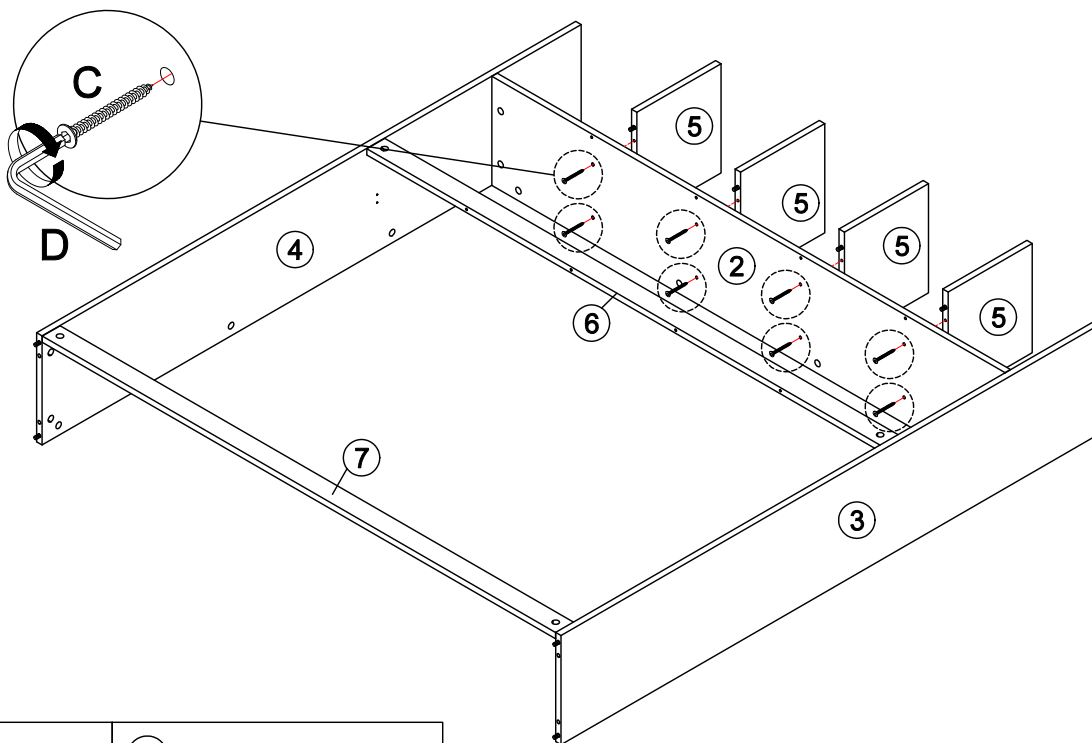

STEP 16

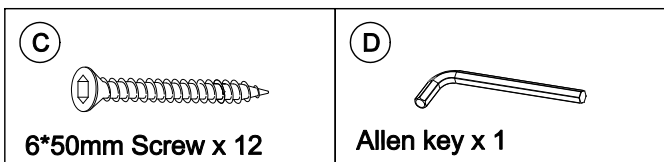
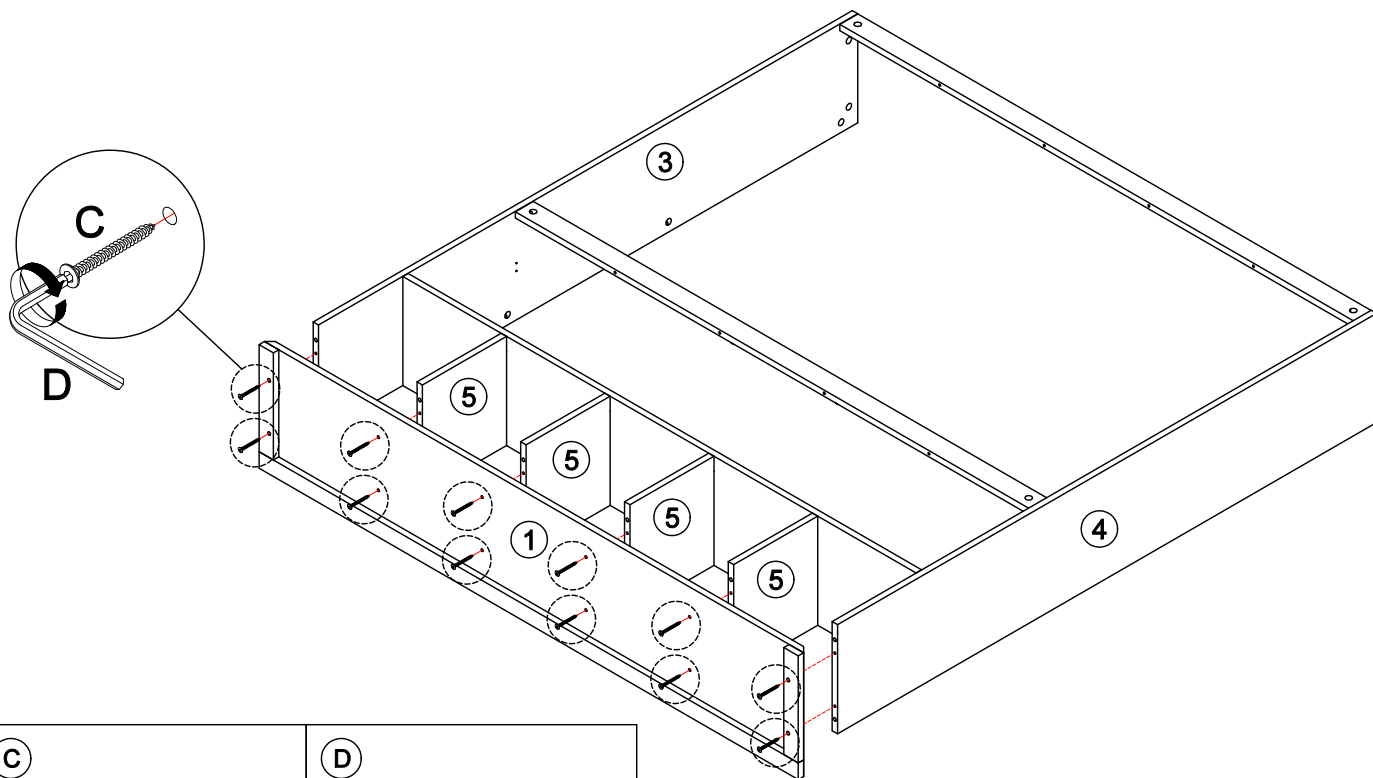

**STEP 17**

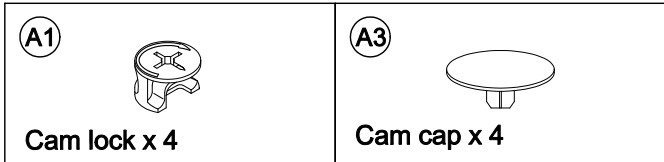
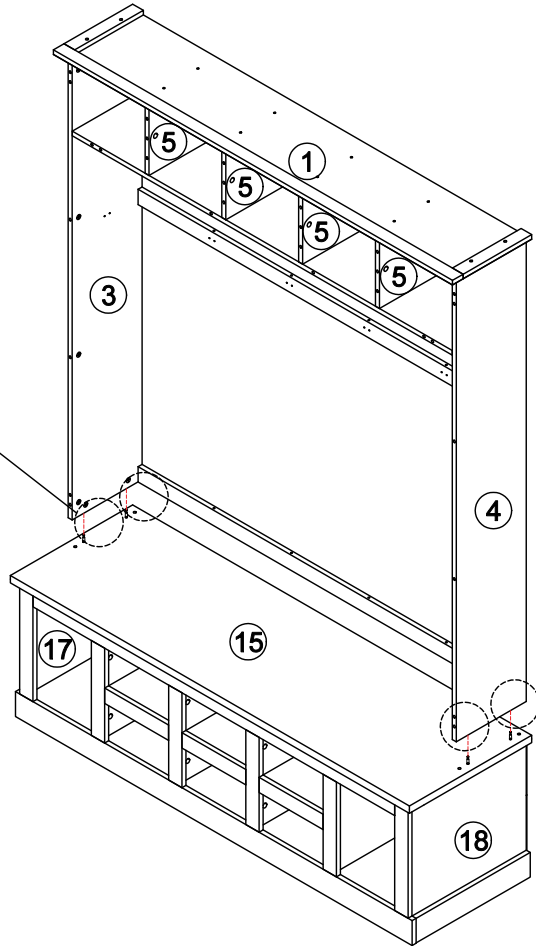
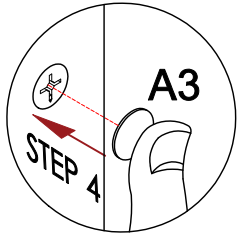
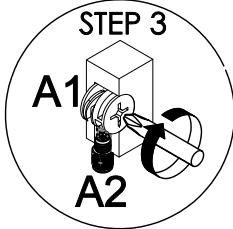
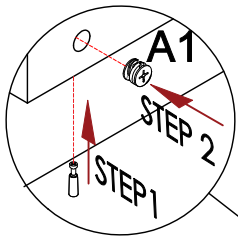

**STEP 18**

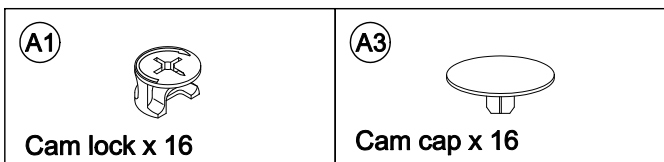
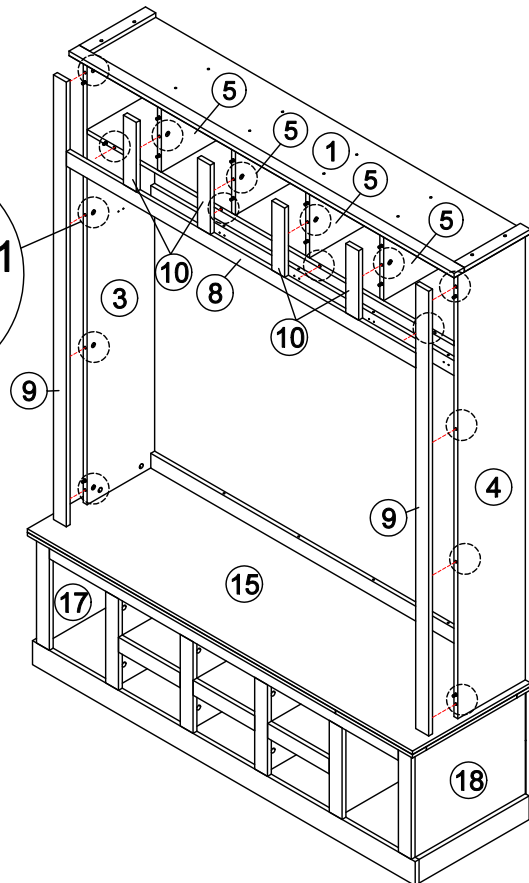
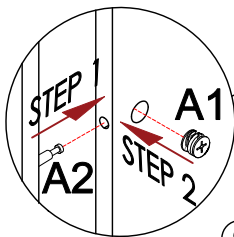
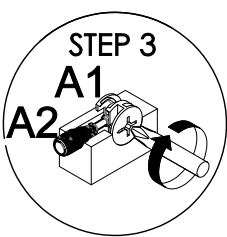
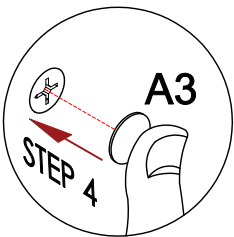

STEP 19

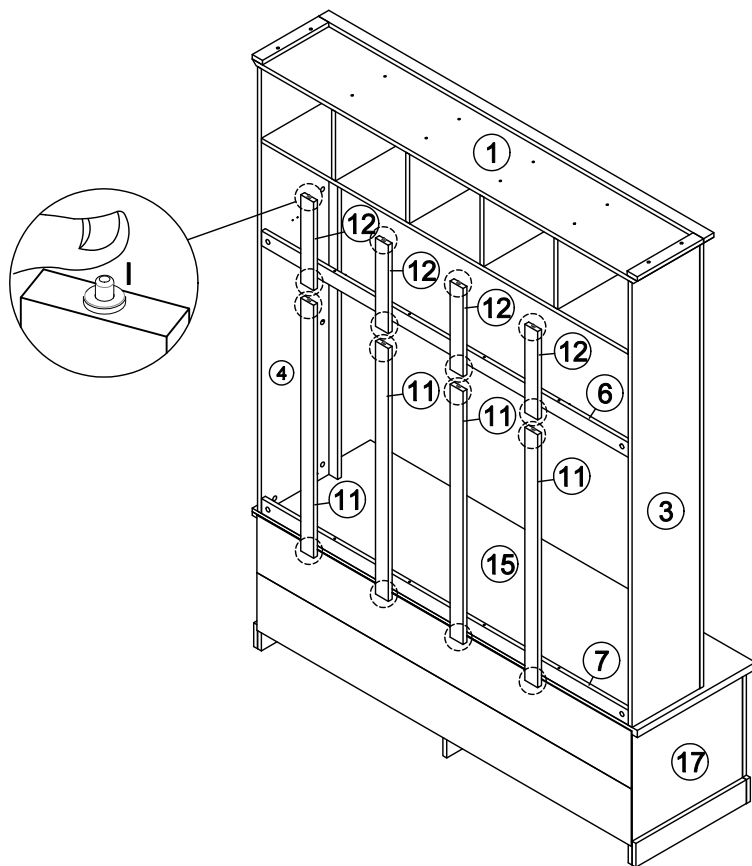

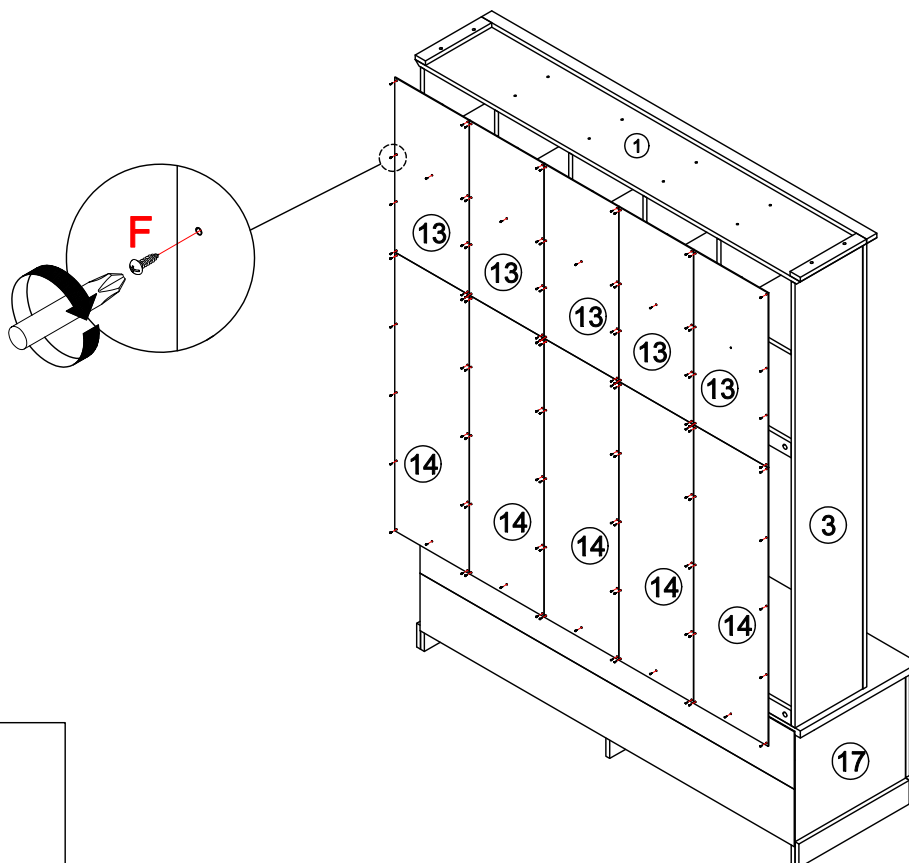

STEP 20



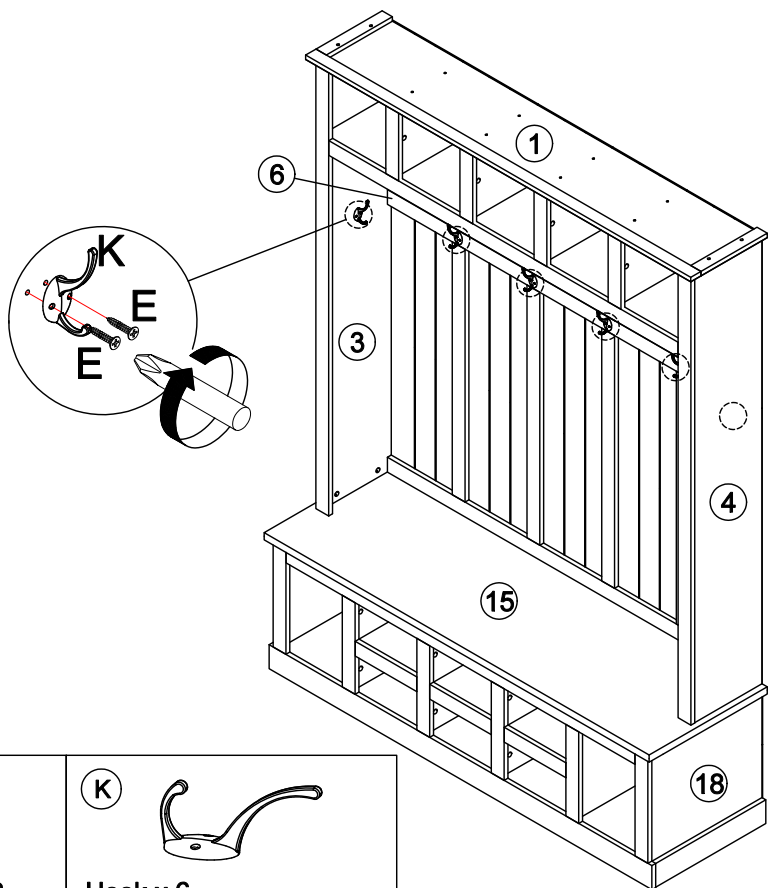

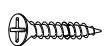
**STEP 21**

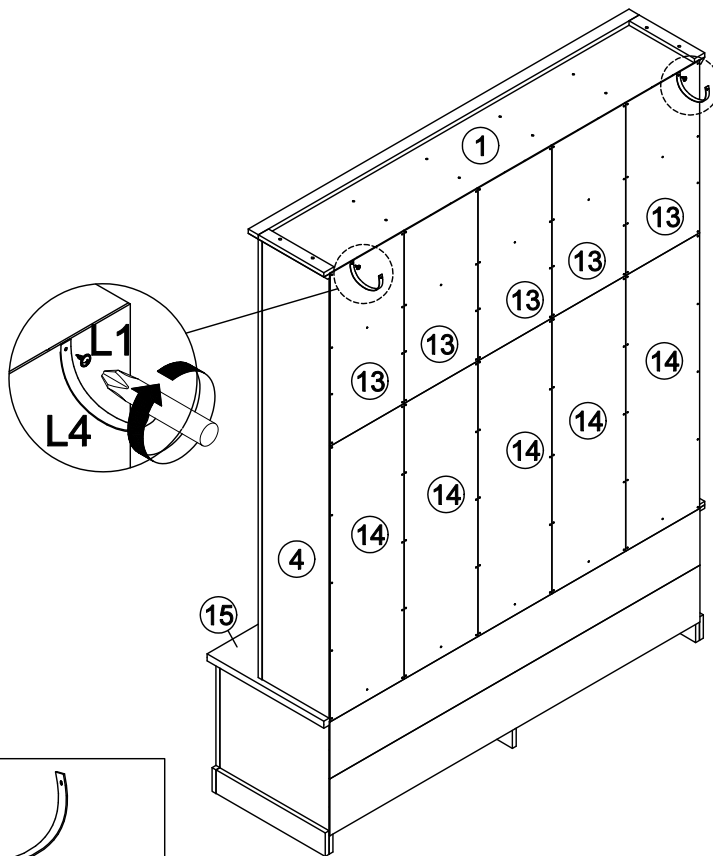

<p><b>(E)</b></p>  <p>3.5*16mm Screw x 12</p>	<p><b>(K)</b></p>  <p>Hook x 6</p>
---	--

**STEP 22**



<p><b>(L1)</b></p>  <p>4*12mm Screw x 2</p>	<p><b>(L4)</b></p>  <p>PVC strip x 2</p>
--	---

STEP 23

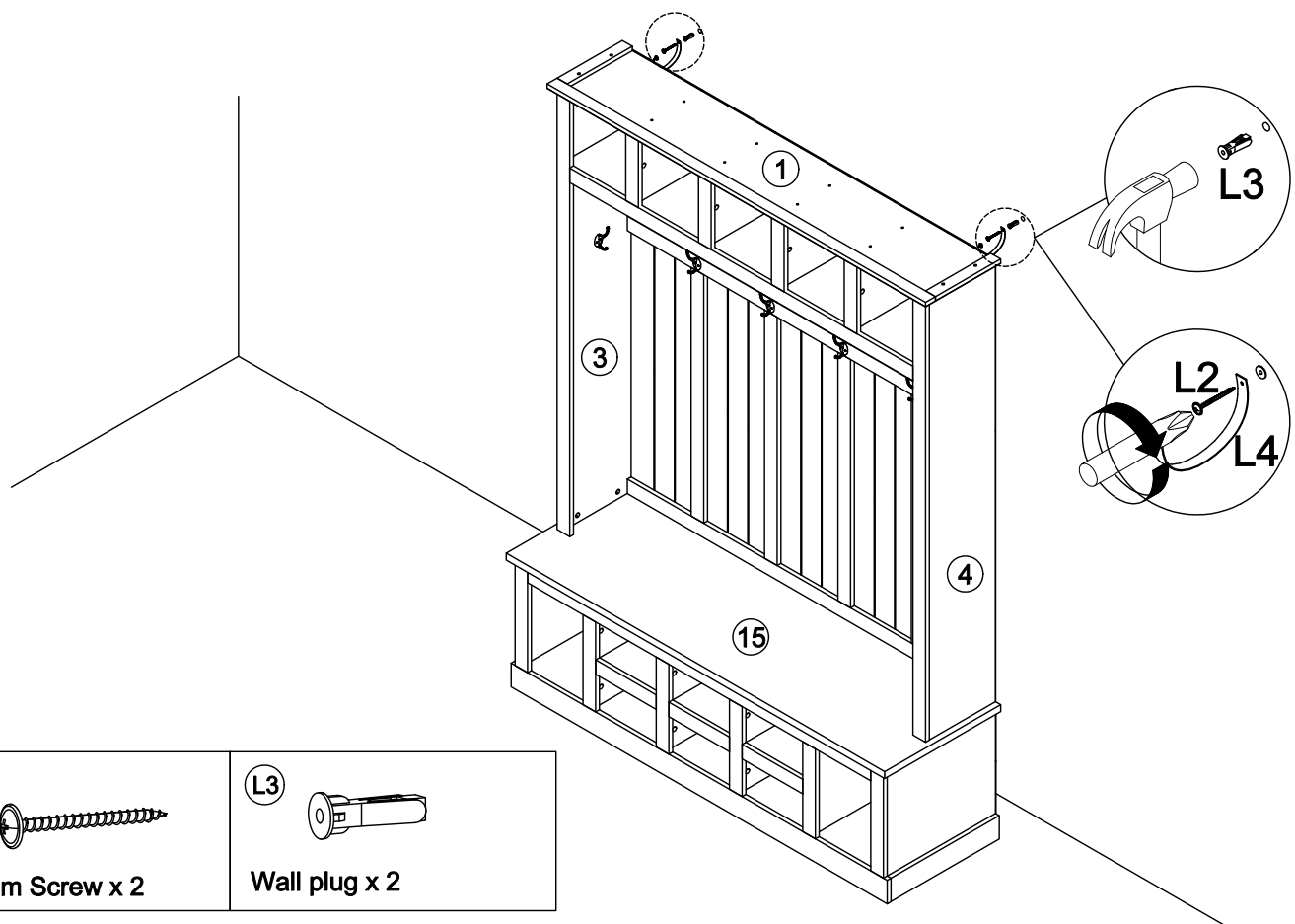

STEP 24

