

# Garden Furniture Set

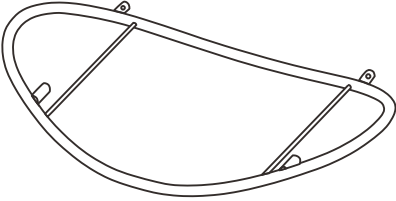

**A** × 2



**B** × 2

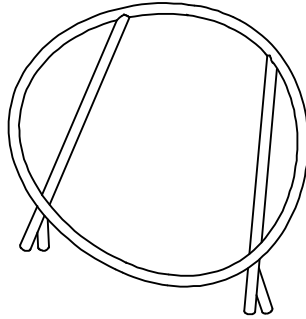

**C** × 2

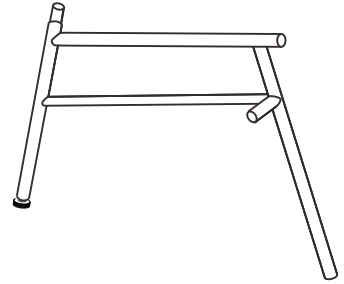

**D** × 2

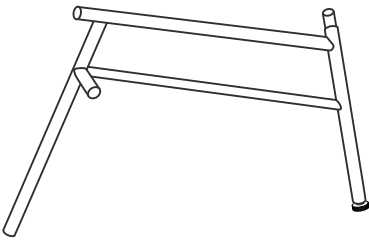

**E** × 2



**F** × 1

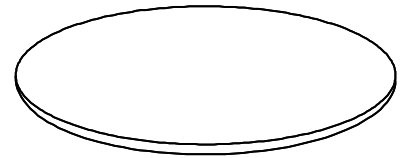

**G** × 1

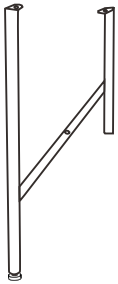

**H** × 1

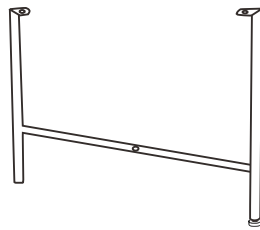

1 × 4

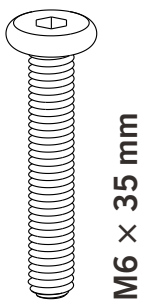

2 × 1

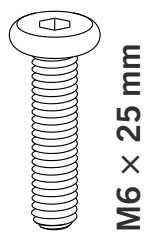

3 × 4

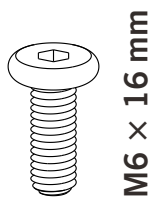

4 × 4



5 × 13

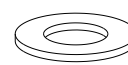

6 × 1

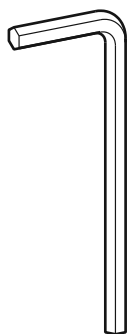

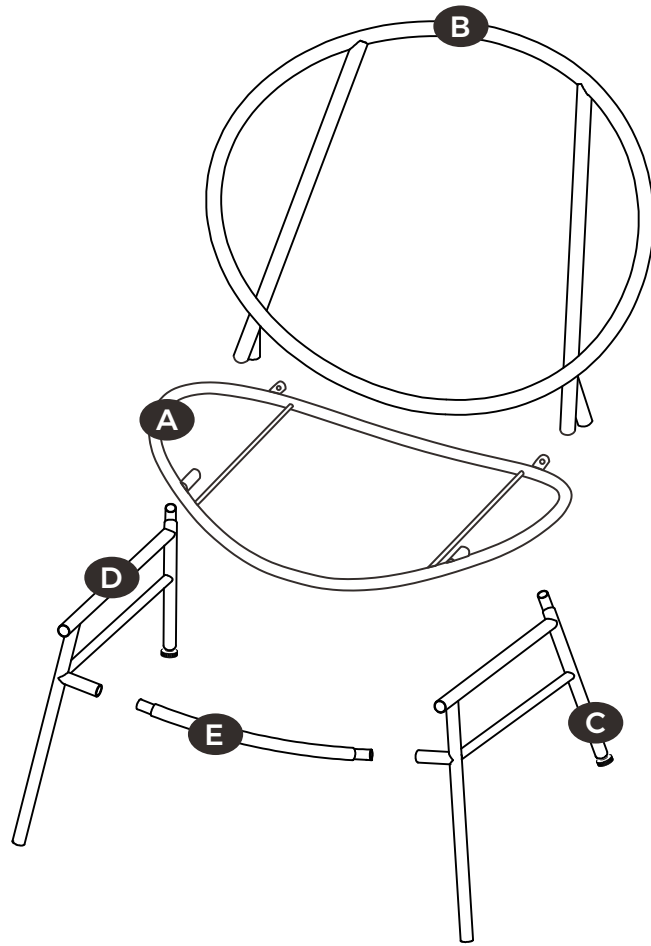

× 2

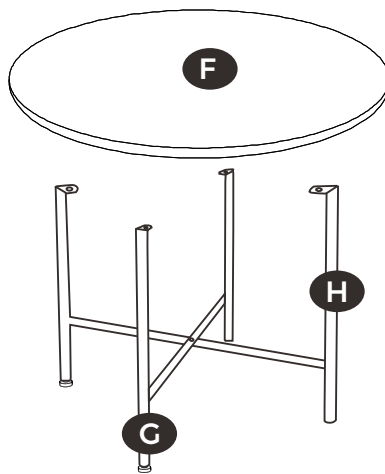

# 1

- EN** • Do not fully tighten the screws.
- DE** • Ziehen Sie die Schrauben nicht ganz fest.
- FR** • Ne serrez pas complètement les vis.
- IT** • Non stringere completamente le viti.
- ES** • No apriete los tornillos a fondo.
- NL** • Draai de schroeven niet volledig vast.
- SE** • Dra inte åt skruvarna helt.
- PL** • Nie dokręcaj śrub do końca.
- TR** • Vidayı tam sıkmayın.

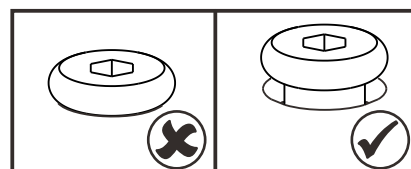

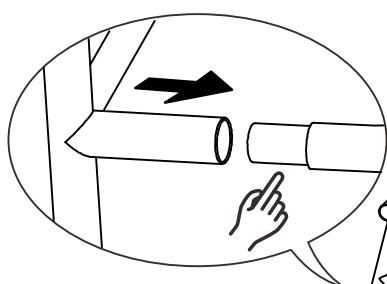

Step 1

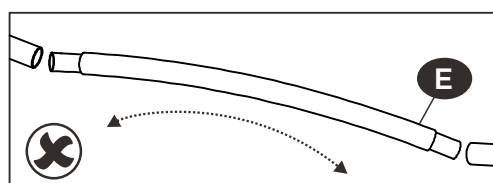
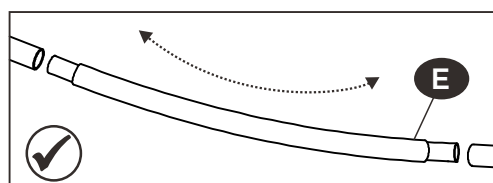
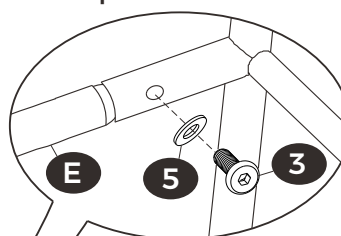

Step 2



× 2

<b>3</b>		× 2
<b>5</b>		× 2

2

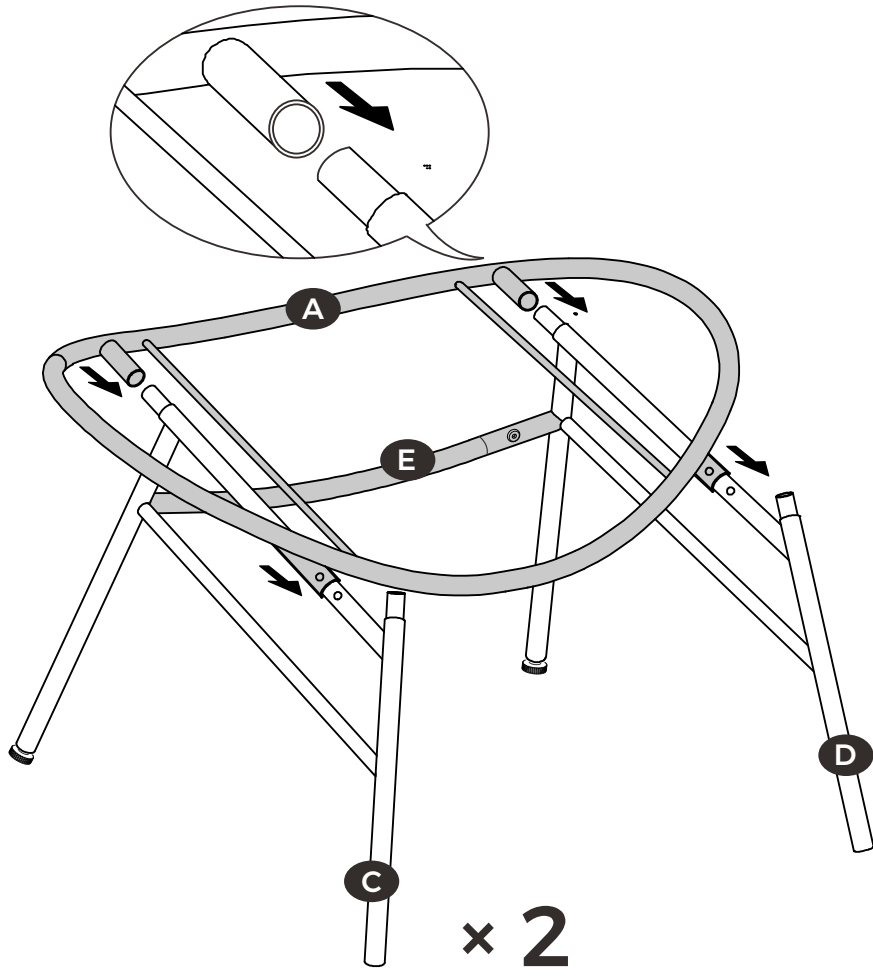

3

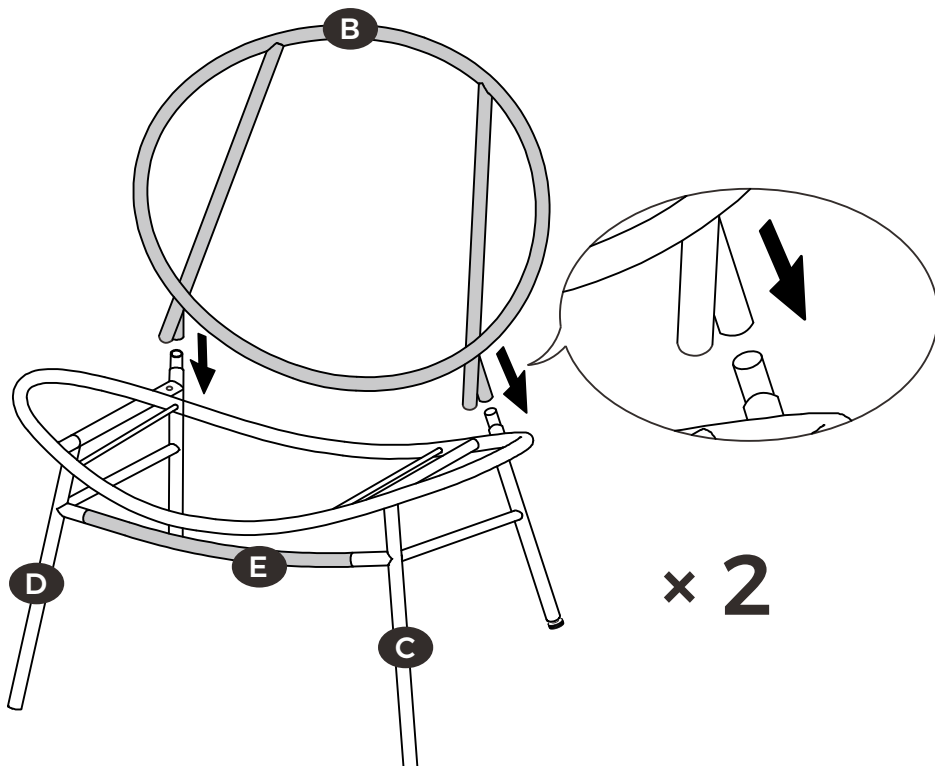

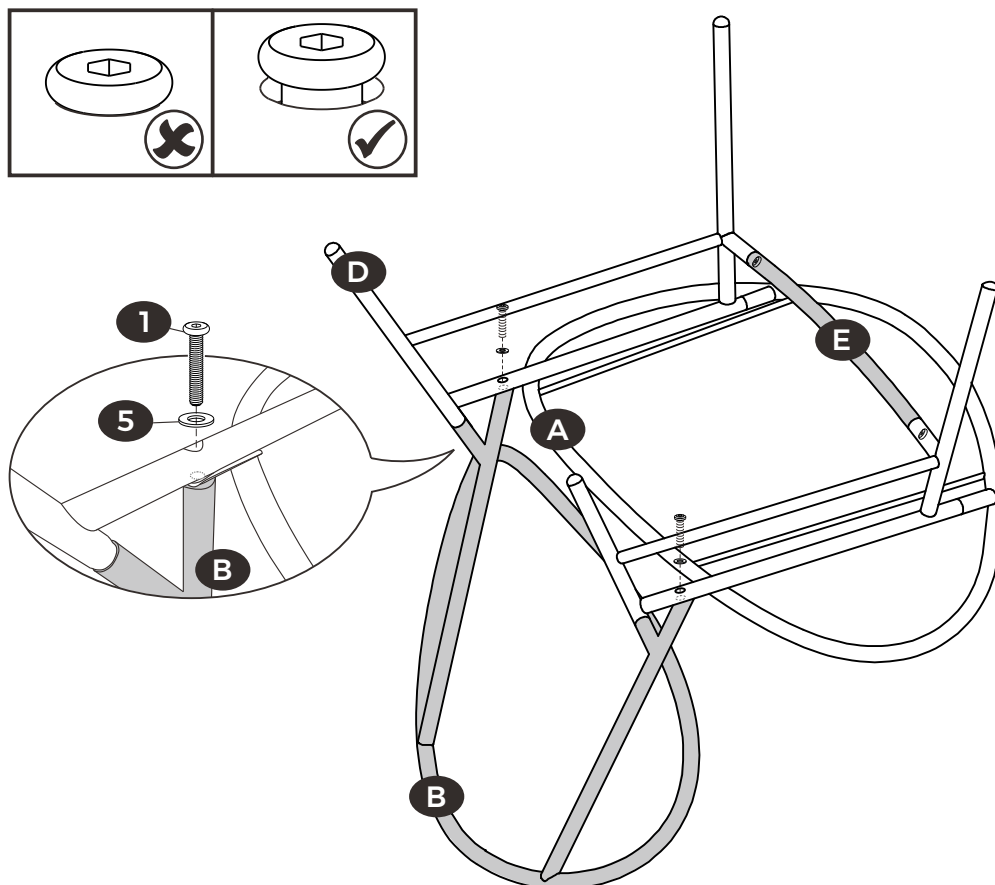
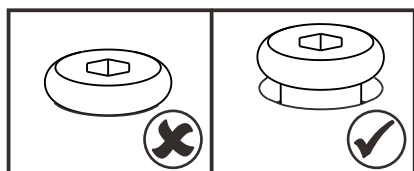

# 4

- EN** • Do not fully tighten the screws.
- DE** • Ziehen Sie die Schrauben nicht ganz fest.
- FR** • Ne serrez pas complètement les vis.
- IT** • Non stringere completamente le viti.
- ES** • No apriete los tornillos a fondo.
- NL** • Draai de schroeven niet volledig vast.
- SE** • Dra inte åt skruvarna helt.
- PL** • Nie dokręcaj śrub do końca.
- TR** • Vidayı tam sıkmayın.

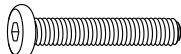

× 2

1		× 2
5		× 2

# 5

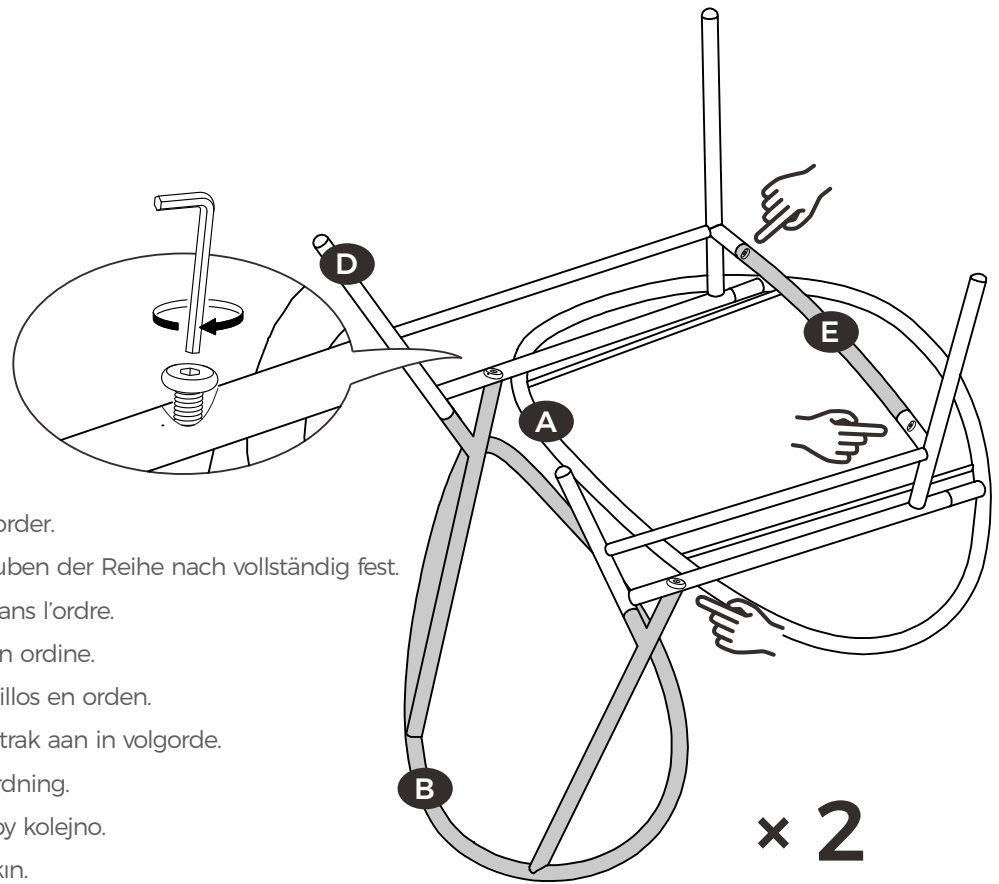

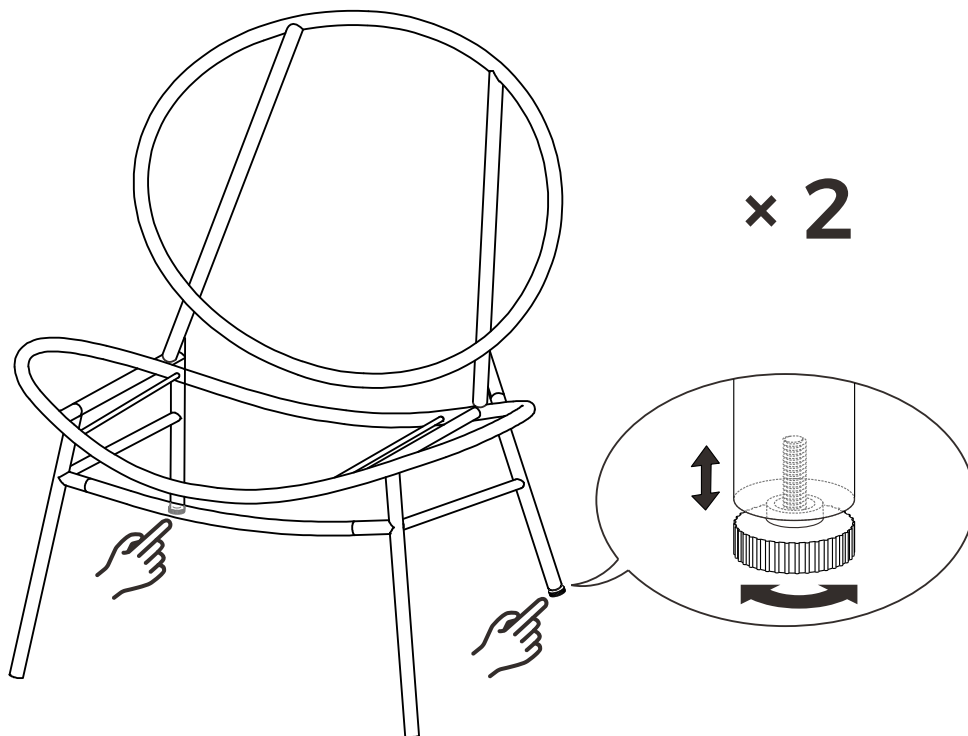

- EN • Tighten all screws in order.
- DE • Ziehen Sie alle Schrauben der Reihe nach vollständig fest.
- FR • Serrez toutes les vis dans l'ordre.
- IT • Stringere tutte le viti in ordine.
- ES • Aprieta todos los tornillos en orden.
- NL • Draai alle schroeven strak aan in volgorde.
- SE • Dra åt alla skruvar i ordning.
- PL • Dokręć wszystkie śruby kolejno.
- TR • Tüm vidaları sırayla sıkın.

# 6

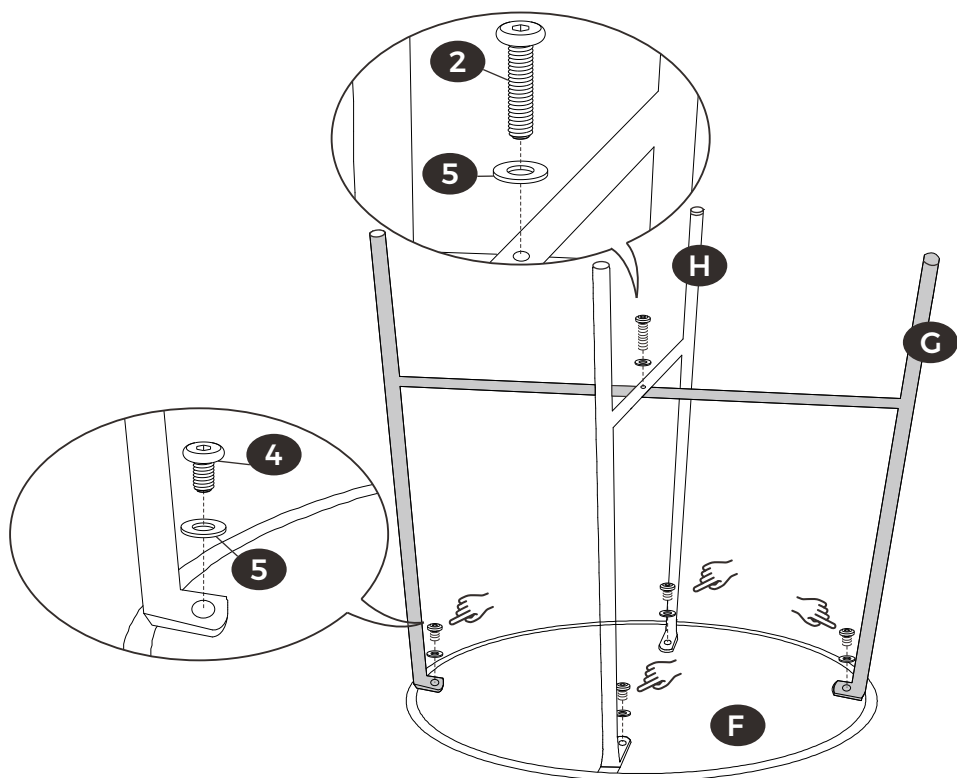

# 7

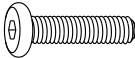

<b>2</b>		<b>x 1</b>	<b>4</b>		<b>x 4</b>	<b>5</b>		<b>x 5</b>
----------	---	------------	----------	---	------------	----------	---	------------

# 8

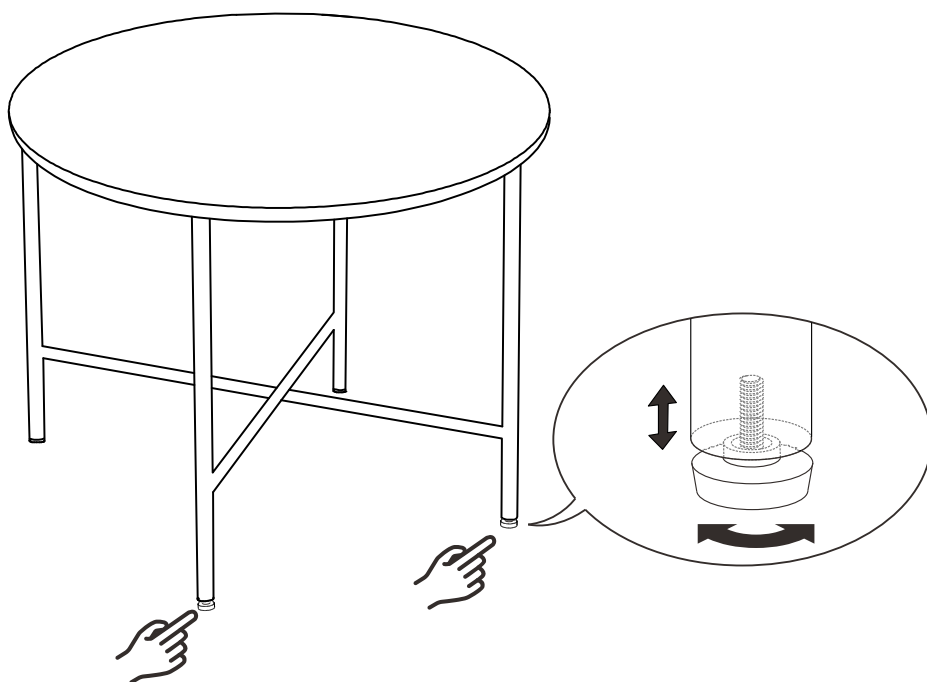

EN

## General Guidelines



Please read the instruction carefully and use the product accordingly.

Please keep this manual and hand it over when you transfer the product.

This summary may not include every detail of all variations and considered steps. Please contact us when further information and help are needed.

FR

## Informations générales



Lisez attentivement ces instructions et utilisez votre produit d'après ce mode d'emploi.

Conservez ces instructions. Si vous souhaitez offrir ce produit à un tiers, joignez obligatoirement ce mode d'emploi.

Pour des raisons de clarté, les détails concernant chaque variante ou montage envisageable ne peuvent être tous décrits. Si vous souhaitez obtenir plus d'informations ou si vous rencontrez certains problèmes non traités de manière détaillée dans ces instructions, veuillez nous contacter.

ES

## Acerca del manual



Por favor, lea detenidamente las instrucciones y respete los debidos usos del producto.

Por favor, conserve bien este manual y en caso de cesión, no omita entregarlo junto al producto.

Este manual podría no incluir todos los detalles de cada paso del montaje. Si necesita ayuda o información adicional, póngase en contacto con nosotros.

DE

## Einleitung



Bitte lesen Sie die Anleitung aufmerksam durch und verwenden Sie das Produkt sachgemäß.

Bewahren Sie diese Anleitung gut auf und händigen Sie sie bei Weitergabe des Produkts an Dritte ebenfalls mit aus.

Aus Gründen der Übersicht können nicht alle Details zu allen Varianten und denkbaren Montagen beschrieben werden. Wenn Sie weitere Informationen und Hilfe benötigen, kontaktieren Sie uns bitte.

IT

## Linee guida generali



Si prega di leggere attentamente le seguenti istruzioni e usare il prodotto in modo opportuno.

Si prega di conservare questo manuale e consegnarlo quando il prodotto cambia proprietario.

Questo riassunto potrebbe non includere ogni dettaglio di tutte le variazioni e le fasi considerate. Contattaci se hai bisogno di ulteriori informazioni e assistenza.

NL

## Algemene Richtlijnen



Gelieve de handleiding na te lezen en het product zo te gebruiken.

Gelieve de handleiding bij te houden, en bij verkoop mee te geven.

Deze samenvatting bevat mogelijks niet alle variaties en stappen. Gelieve contact op te nemen indien u meer informatie of hulp nodig hebt.

SE

## Allmänna riktlinjer



Var god läs följande instruktioner noggrant och använd produkten därefter.

Var god behåll den här bruksanvisningen och överlämna den när du överför produkten.

Denna sammanfattning kanske inte innehåller alla detaljer i alla variationer och övervägda steg. Vänligen kontakta oss när ytterligare information och hjälp behövs.

TR

## Genel kurallar



Lütfen aşağıdaki talimatları dikkatlice okuyun ve ürünü belirtildiği şekilde kullanın.

Lütfen bu kılavuzu saklayın ve ürünü teslim ederken karşı tarafa verin.

Bu özet, tüm varyasyonları ve dikkate alınan adımları bütünüyle içermeyebilir. Ek bilgi veya yardım gerekirse lütfen bizimle iletişime geçin.

PL

## Ogólne Porady



Proszę uważnie przeczytać niniejsze instrukcje oraz odpowiednio używać produkt.

Proszę przechowywać tą instrukcję oraz przekazać razem z produktem podczas transferu zmiany własności.

Podsumowanie to może nie zawierać wszystkich detali każdej z wersji oraz uwzględnionych kroków. Proszę skontaktuj się z nami jeśli potrzebujesz więcej informacji albo pomocy.