

Installation Instruction

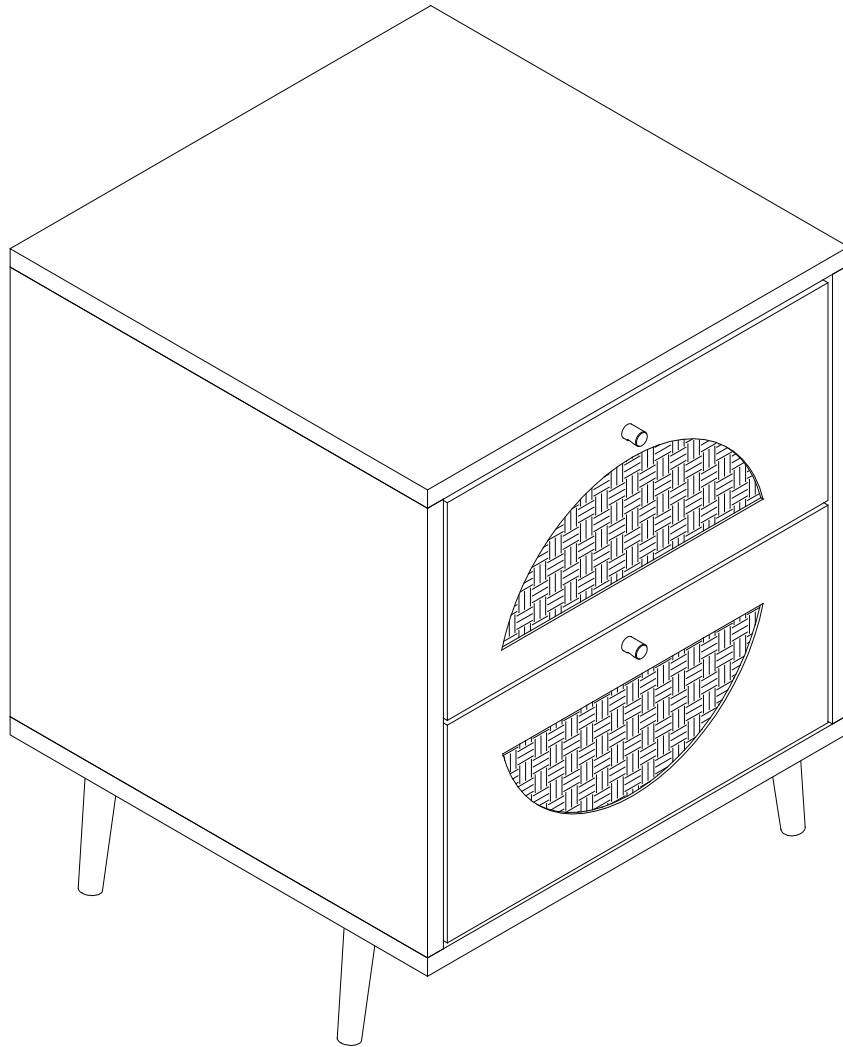

Assembling

Estimated time for assembly



25 : 00

What you need

- Use the packaging carton as a working surface to prevent product damage during assembly
- Phillips head screwdriver

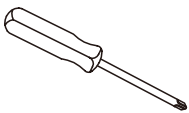

Weight Limitation



55 | **11**
lbs table top lbs per drawer

What's included

| Code | Description | Qty |
|------|------------------------|-----|
| A | Cam Bolt M6X35MM | 12 |
| B | Cam Lock 15X10MM | 12 |
| C | Screw M4X35MM | 12 |
| D | Screw M3.5X12MM | 24 |
| E | Screw 4X12MM | 20 |
| F | Wooden Dowel M6X30MM | 8 |
| G | Bolt 4X16MM | 2 |
| H | Handle | 2 |
| I | Metal Pin Hinge | 4 |
| J | Slide Sets | 2 |
| K | Plastic corner support | 4 |
| L | Screw M3X16MM | 4 |

The Hardwares

A

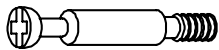

B



C

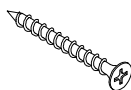

D



E

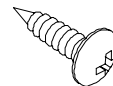

F

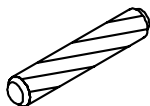

G



H



I

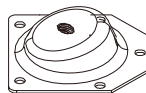

J

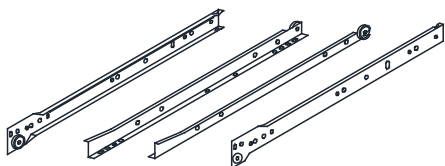

CL DL DR CR

K



L



IMPORTANT:

1. Do not tighten bolts / screws completely until all bolts / screws are lined up and inserted into holes.
2. Do not over tighten screws and bolts to avoid stripping.
3. Please use hand tools to assemble this product. Do not use power tools.

Included Accessories

| Code | Description | Qty |
|-------------|--------------------------|------------|
| 1 | Cabinet Top | 1 |
| 2 | Left Side Panel | 1 |
| 3 | Right Side Panel | 1 |
| 4 | Bottom panel | 1 |
| 5 | Back Panel | 1 |
| 6 | Drawer Back Panel | 2 |
| 7 | Drawer Left Side Panel | 2 |
| 8 | Drawer Right Side Panel | 2 |
| 9 | Drawer Bottom Panel | 2 |
| 10 | Drawer Left Front Panel | 1 |
| 11 | Drawer Right Front Panel | 1 |
| 12 | FEET | 4 |

The Accessoriess

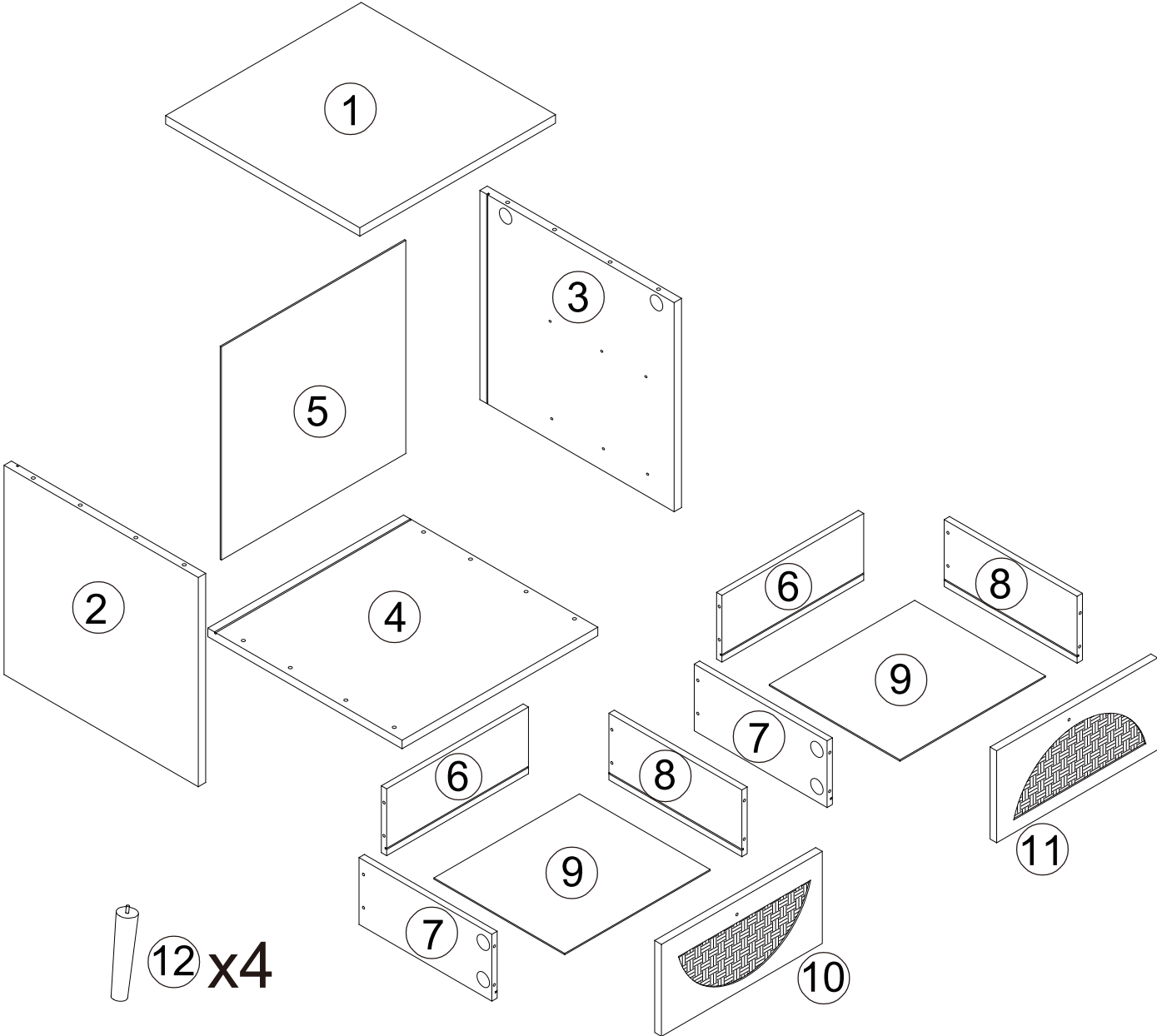

Step 1

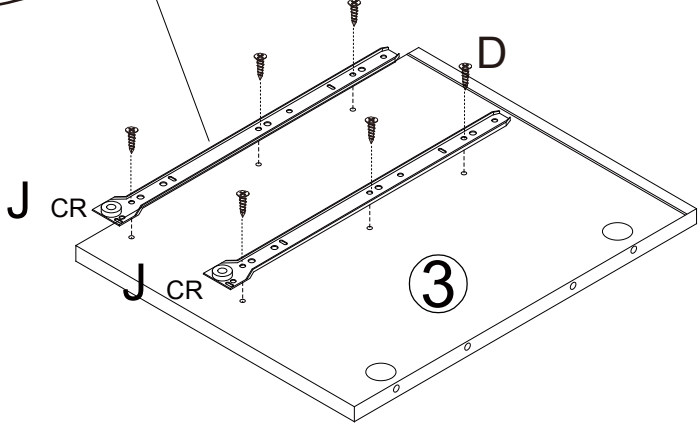
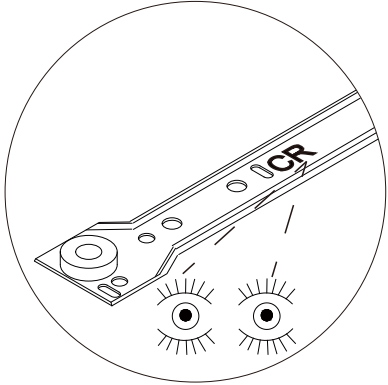
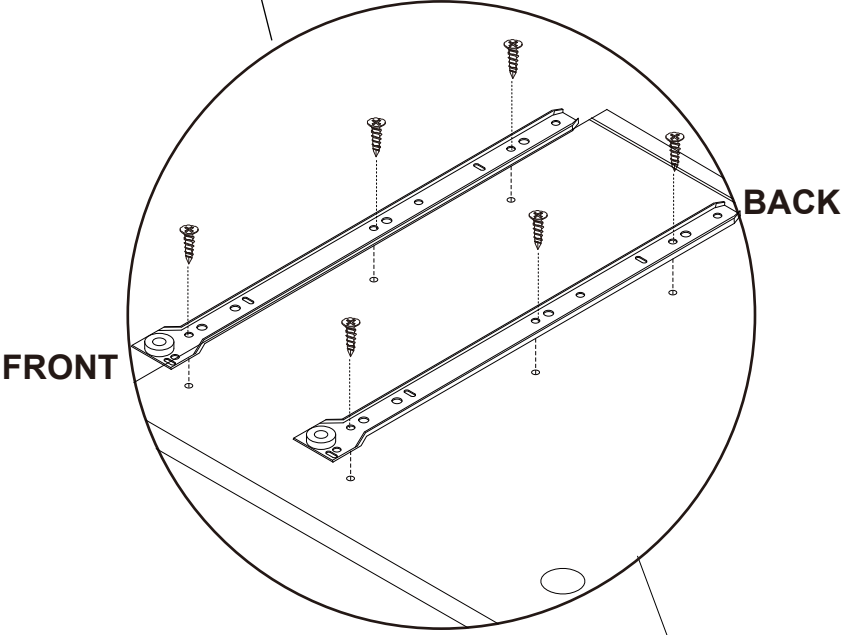
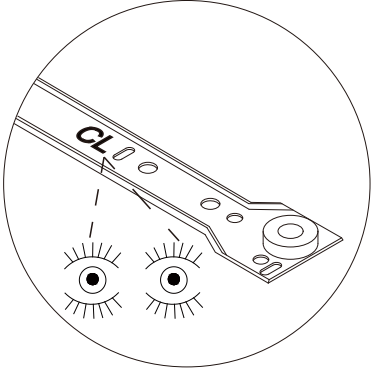
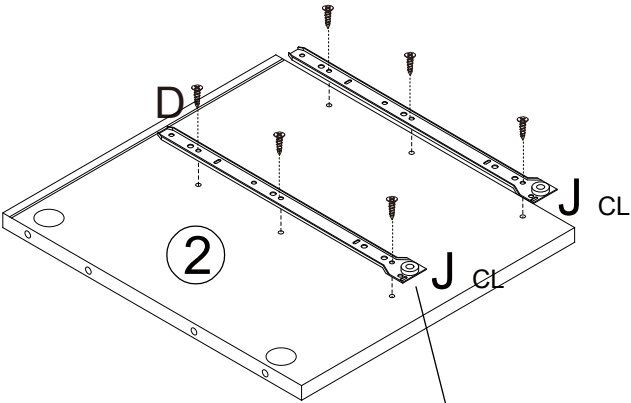
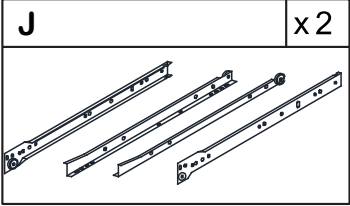
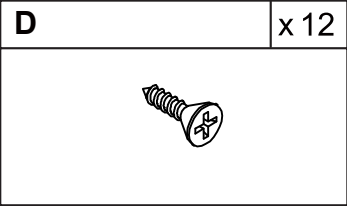

Step 2

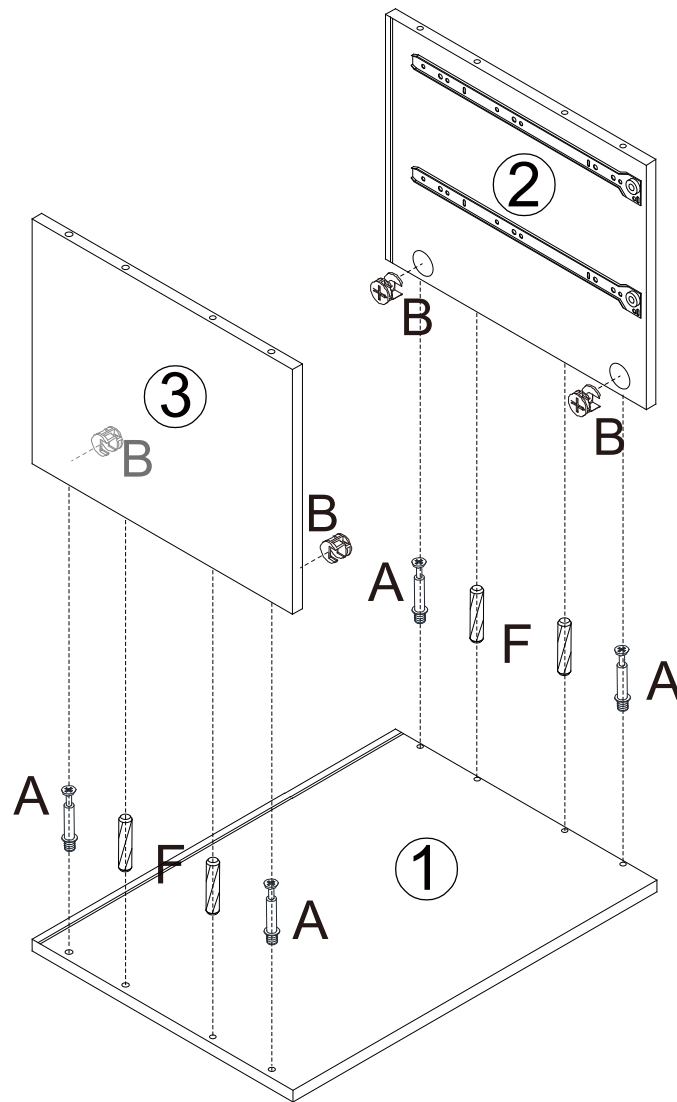
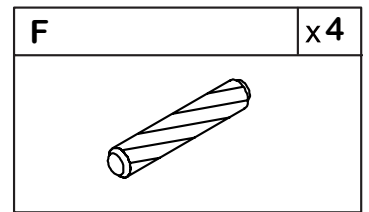
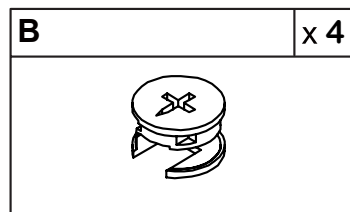
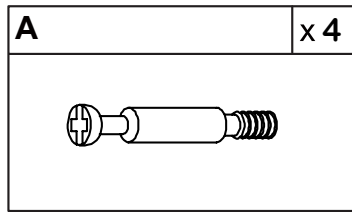

Step 3

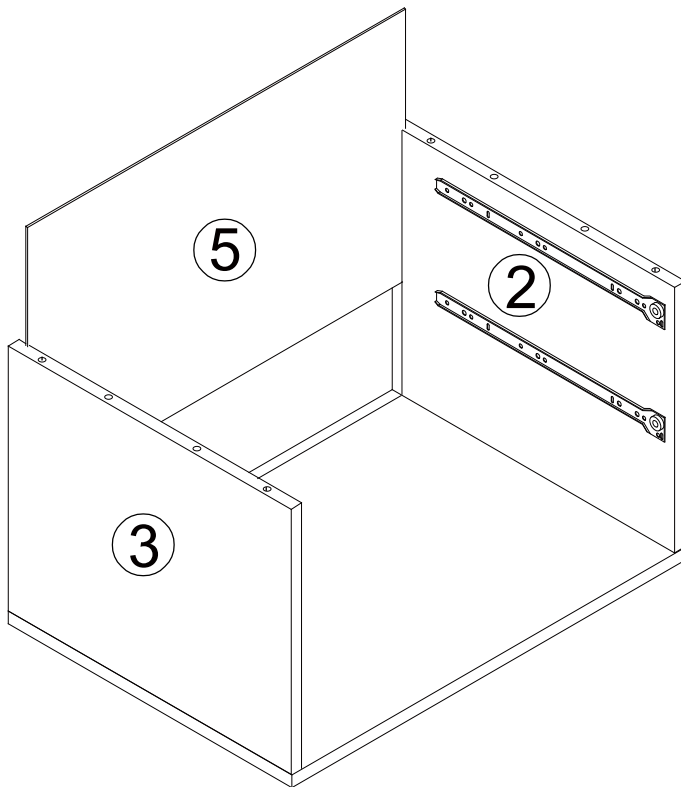

Step 4

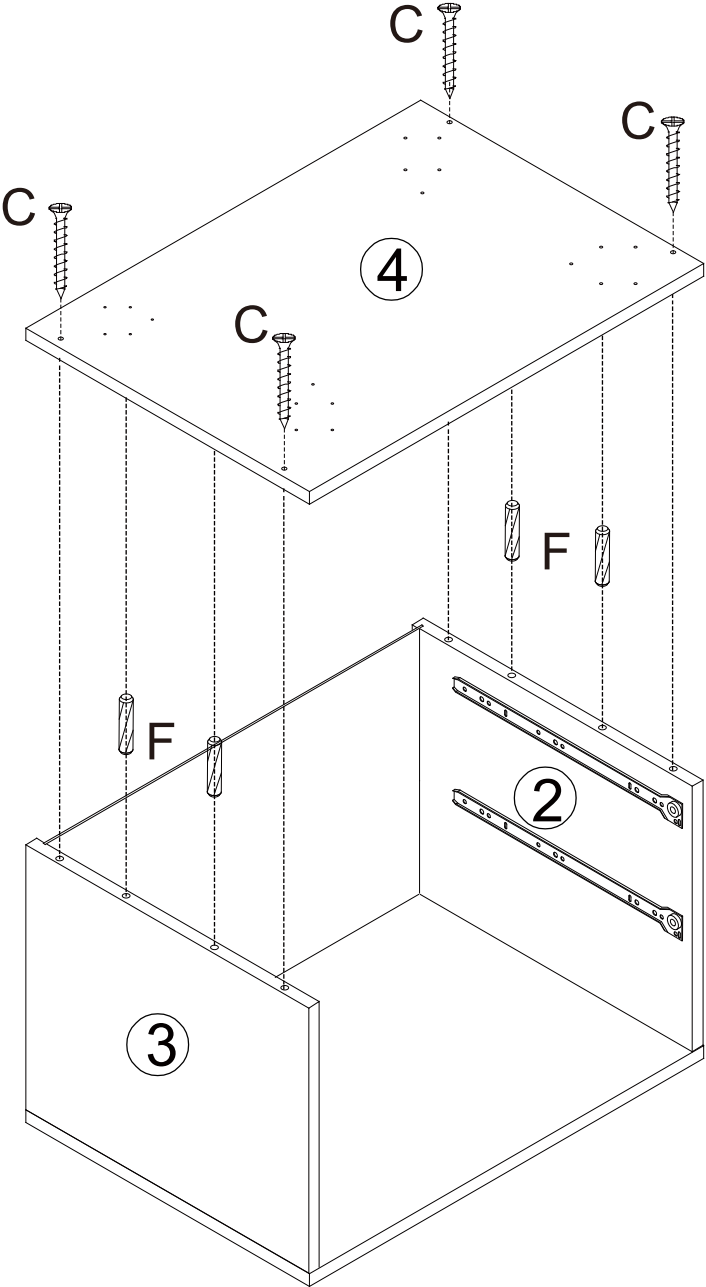
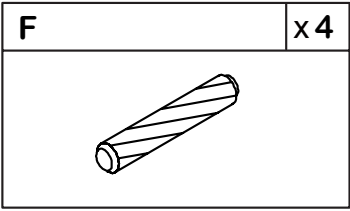
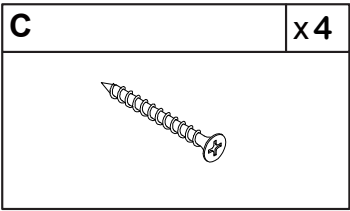

Step 5

| | |
|---|-----------|
| K | x4 |
|  | |

| | |
|---|-----------|
| L | x4 |
|  | |

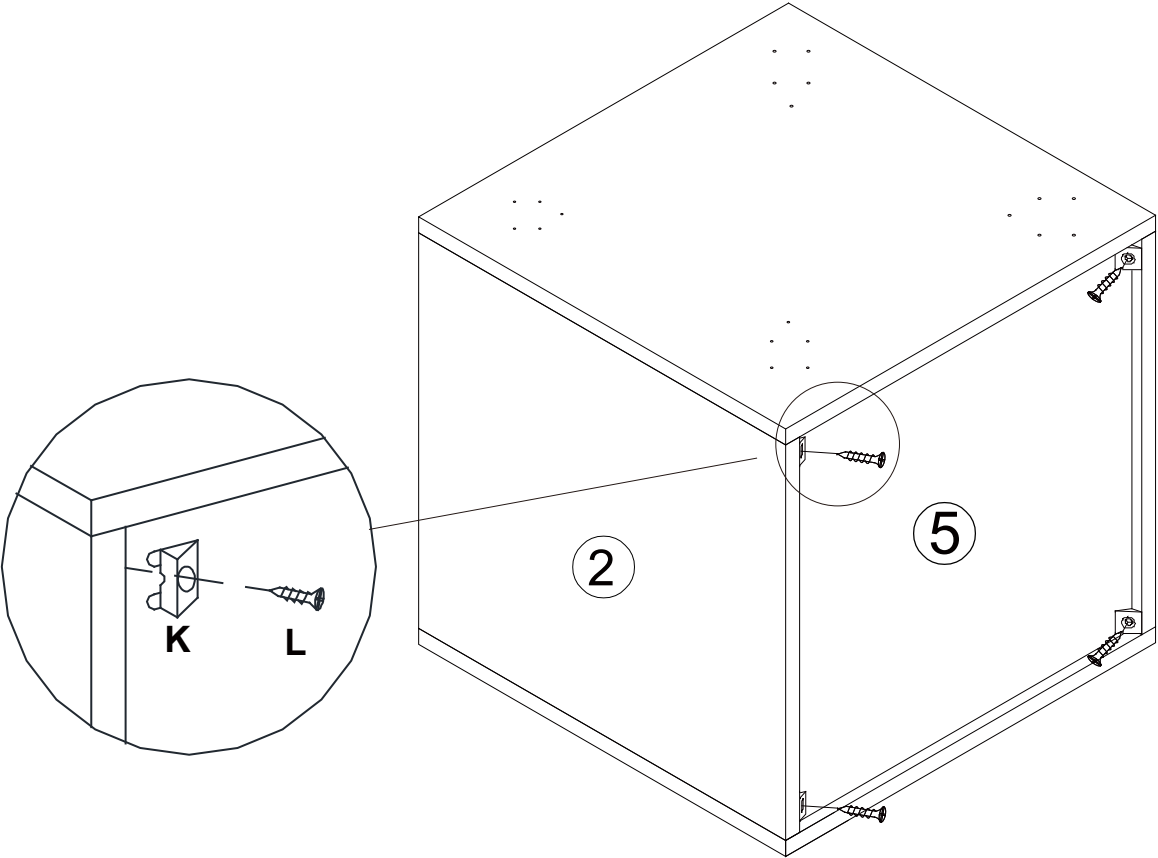

Step 6

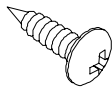
| | |
|--|------------|
| E | x20 |
|  | |

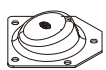
| | |
|---|-----------|
| I | x4 |
|  | |

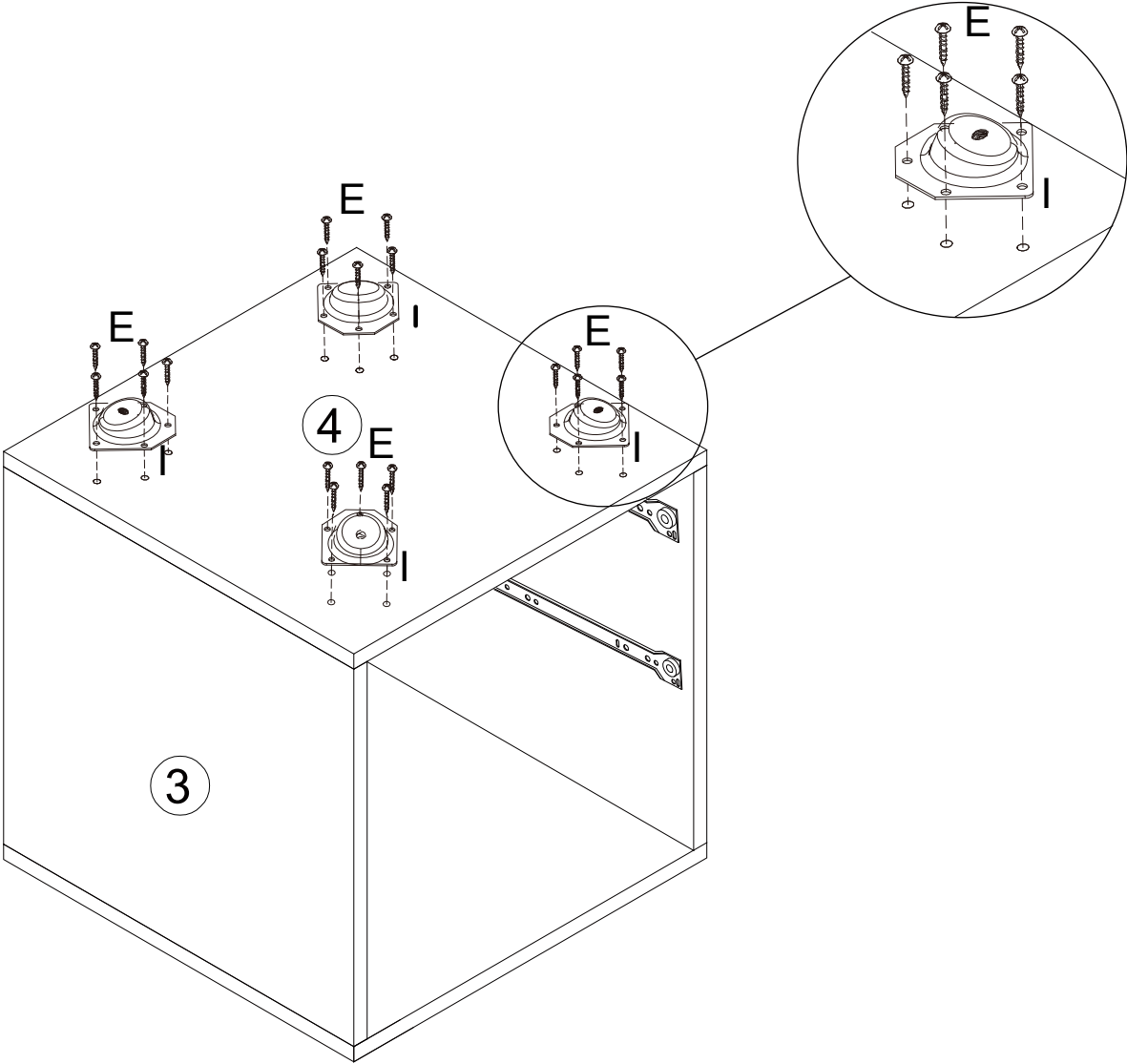

Step 7

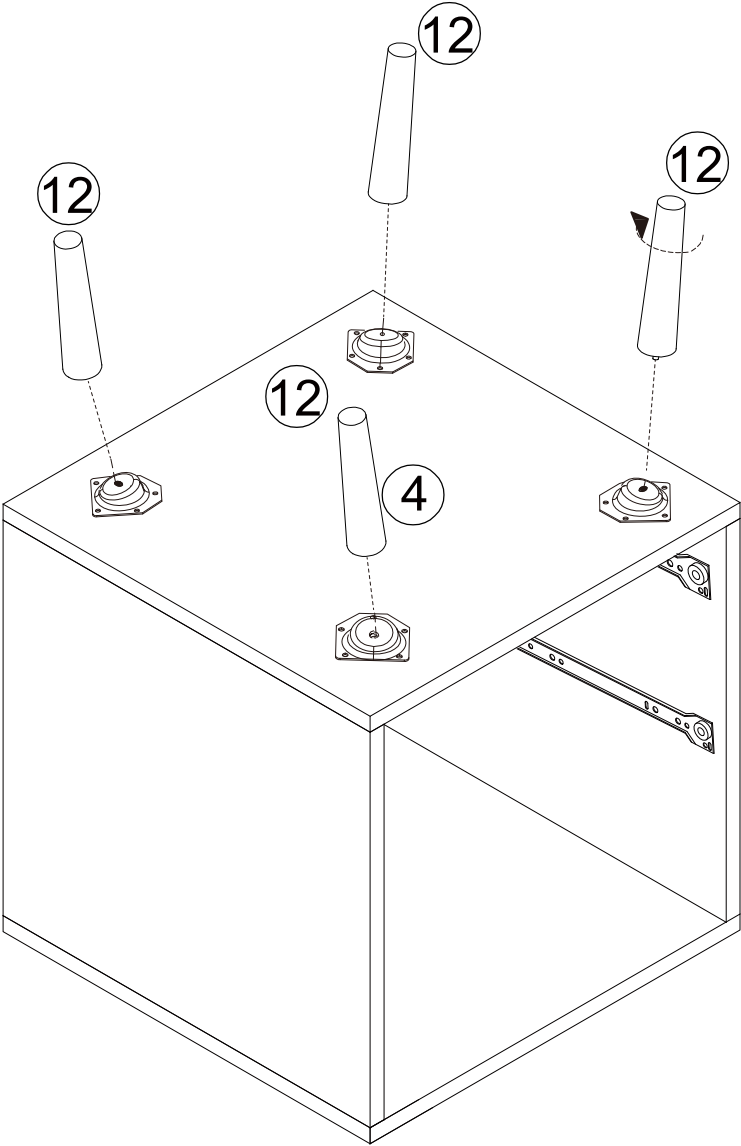

Step 8

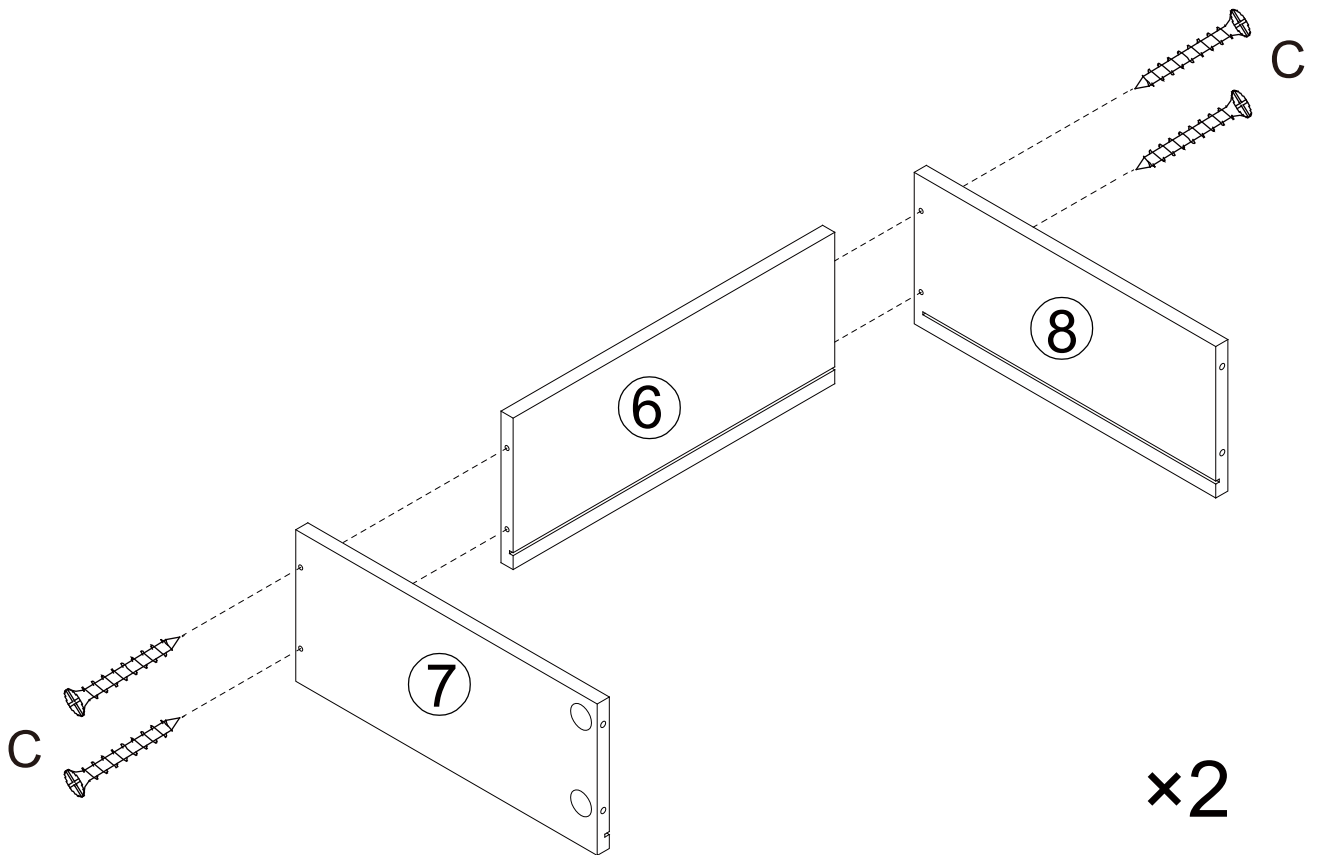
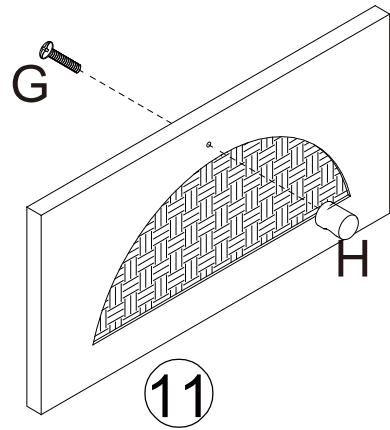
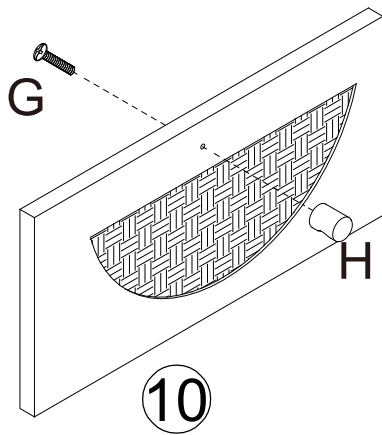
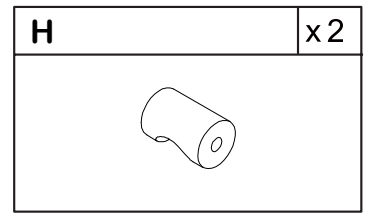
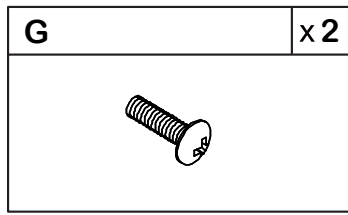
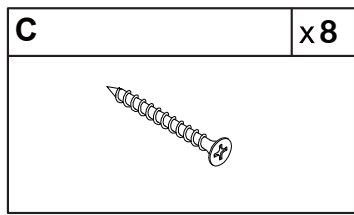

Step 9

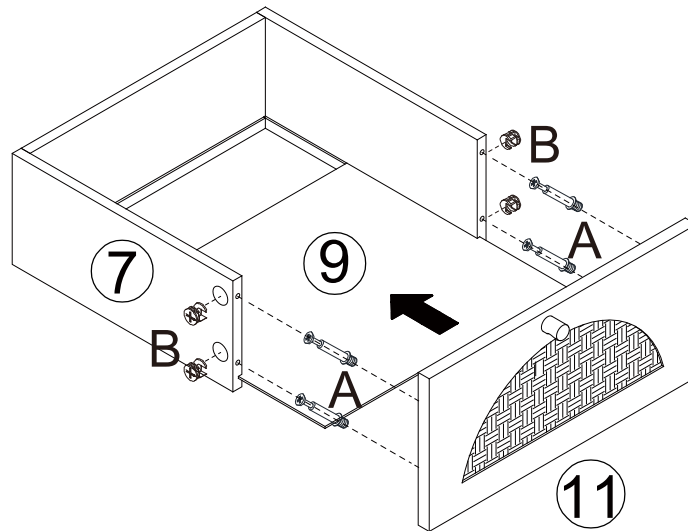
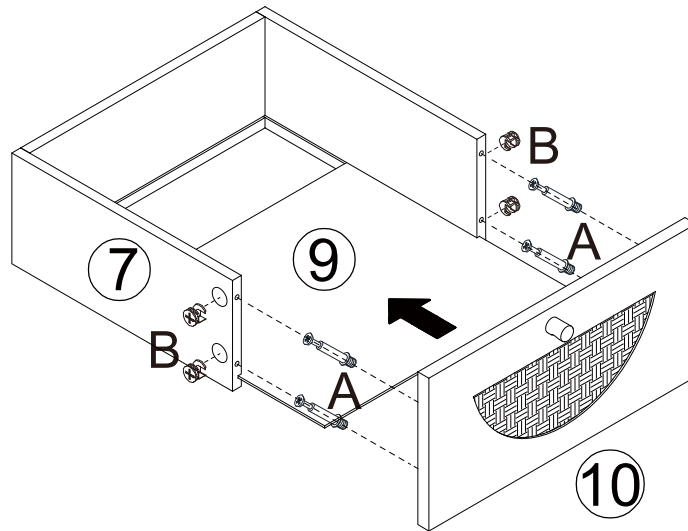
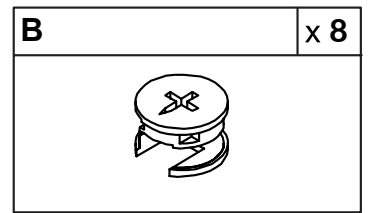
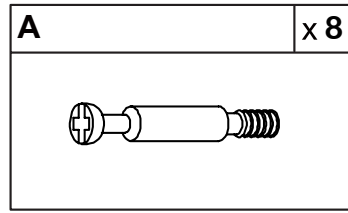

Step 10

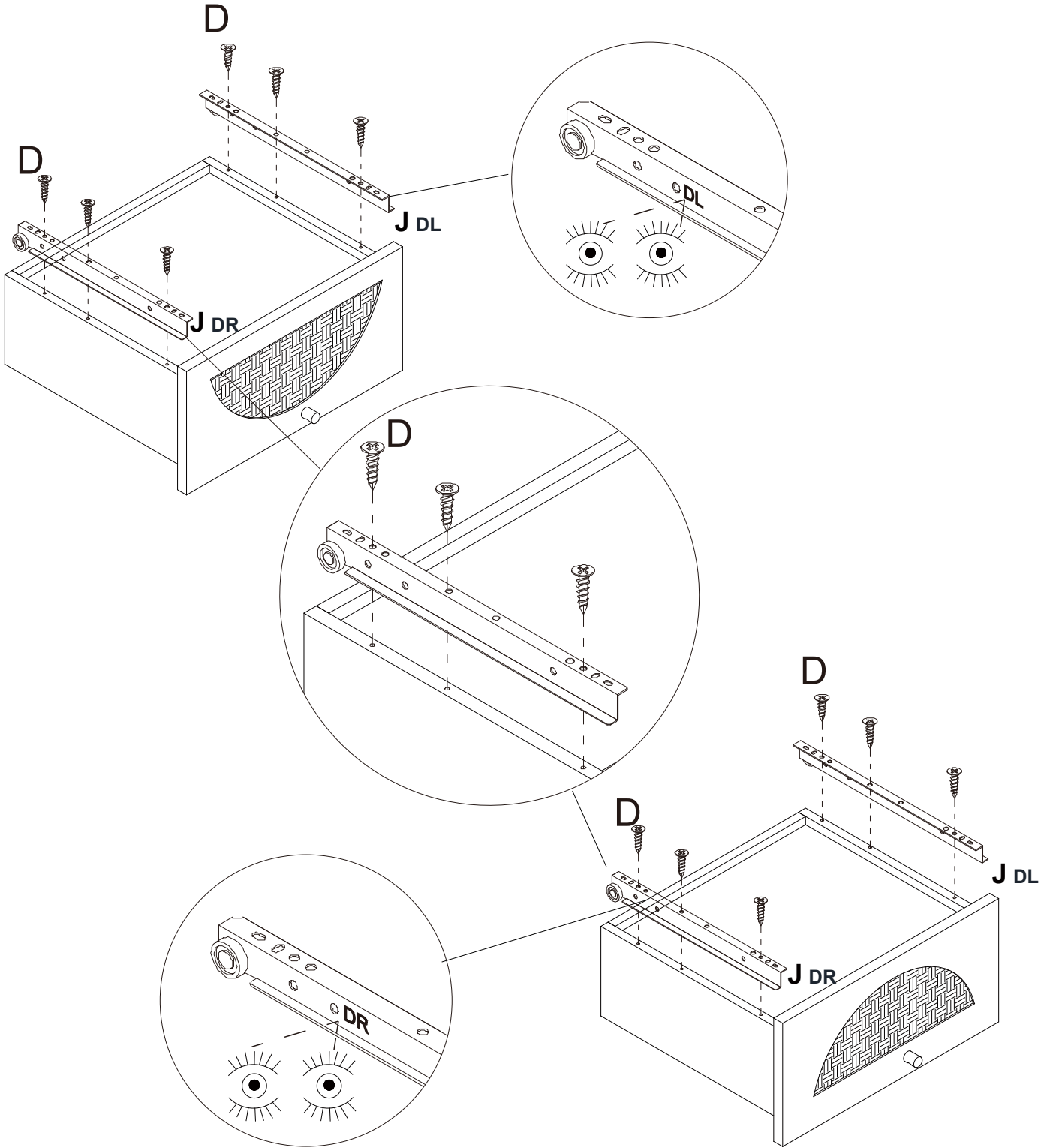
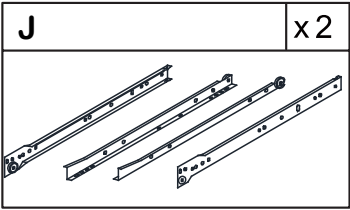
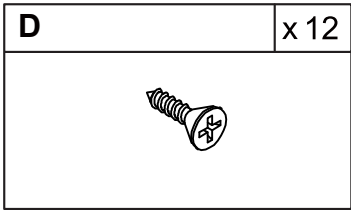

Step 11

