







ASSEMBLY INSTRUCTIONS

HARDWARE LIST

NO.	SKETCH	DESCRIPTION	QTY
1		Bolt(1/4"x1-7/8")	4 PCS
2		Bolt(1/4"x7/8")	2 PCS
3		Spring Washer(1/4")	6 PCS
4		Washer(1/4")	6 PCS
5		Allen wrench(4mm)	1 PC
6		Plastics Cap	2 PCS

PARTS LIST

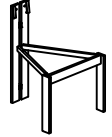
NO.	SKETCH	DESCRIPTION	QTY
A		Seat	1 PC
B		Backrest	1 PC
C		Metal frame	1 PC

Pre-Installation Notes:

1. Please check all parts against the list.
2. Position all components in the correct order as specified.
3. Hand-tighten all screws to 50% torque (do not fully tighten at this stage).
4. Ensure all screw holes are properly aligned before proceeding.
5. Once alignment is confirmed, fully tighten all screws to secure the cushion in place.

Important Note:

Do not overtighten screws, as this may damage the threads or components.

Step 1: Seat Installation

Position the cushion holes directly over the corresponding frame holes.

Insert screws in the sequence shown in right.

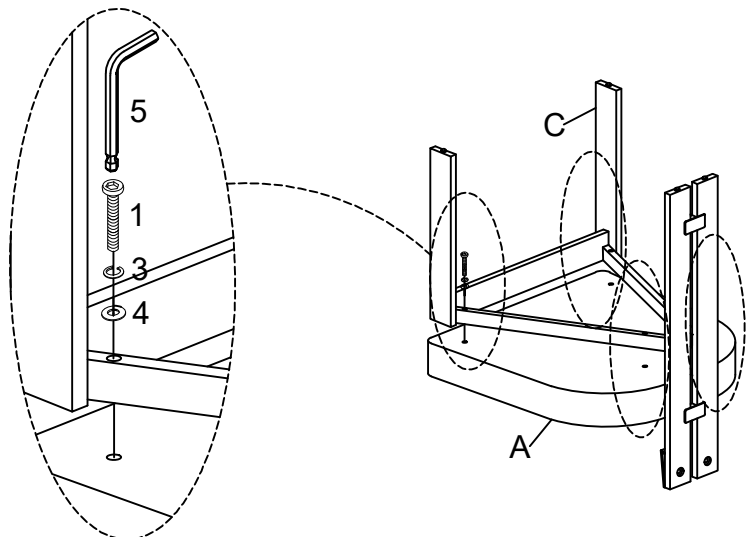

ASSEMBLY INSTRUCTIONS

Step 2: Backrest Installation

Insert screws in the sequence shown in below.

Note the screws used in this step is screw 2 ,which shorter then 1.

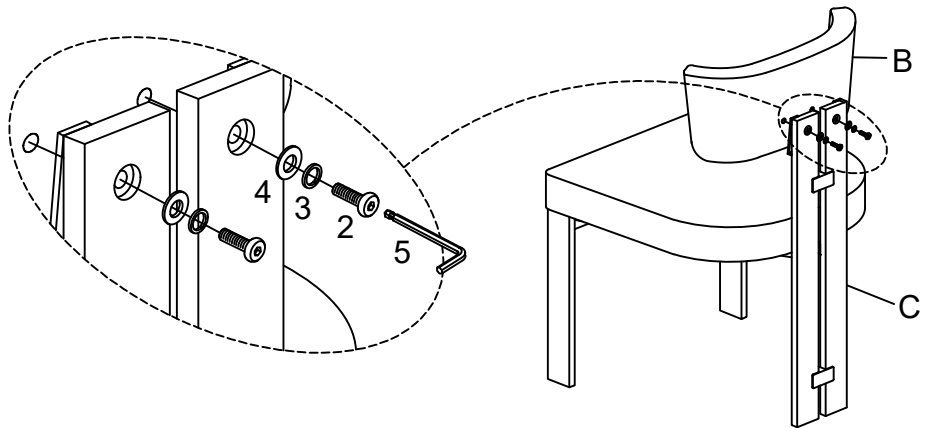

Step 3: Plastics cap Installation

After completing the installation of the step 2, first check if the installation is proper, and then install the plastics cap.

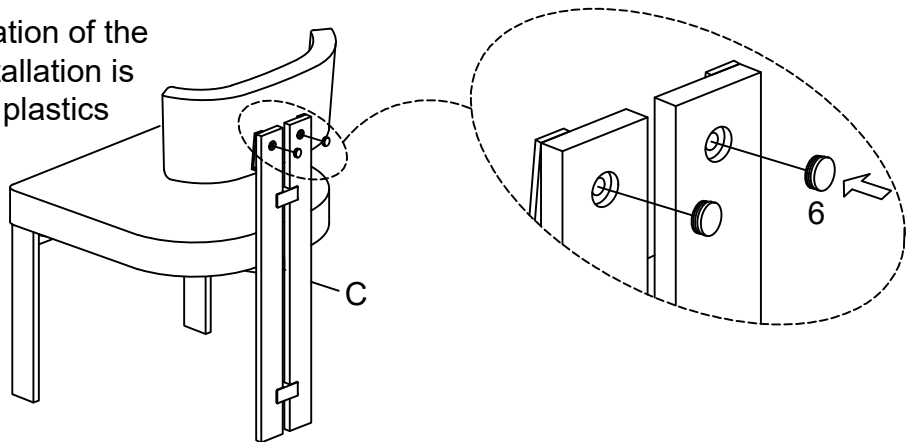

Step 4: Final Inspection

After it is fully installed, please check if the chair is wobbling, unstable or has any defects.

Wishing you a pleasant user experience.

