

# Assembly Instructions

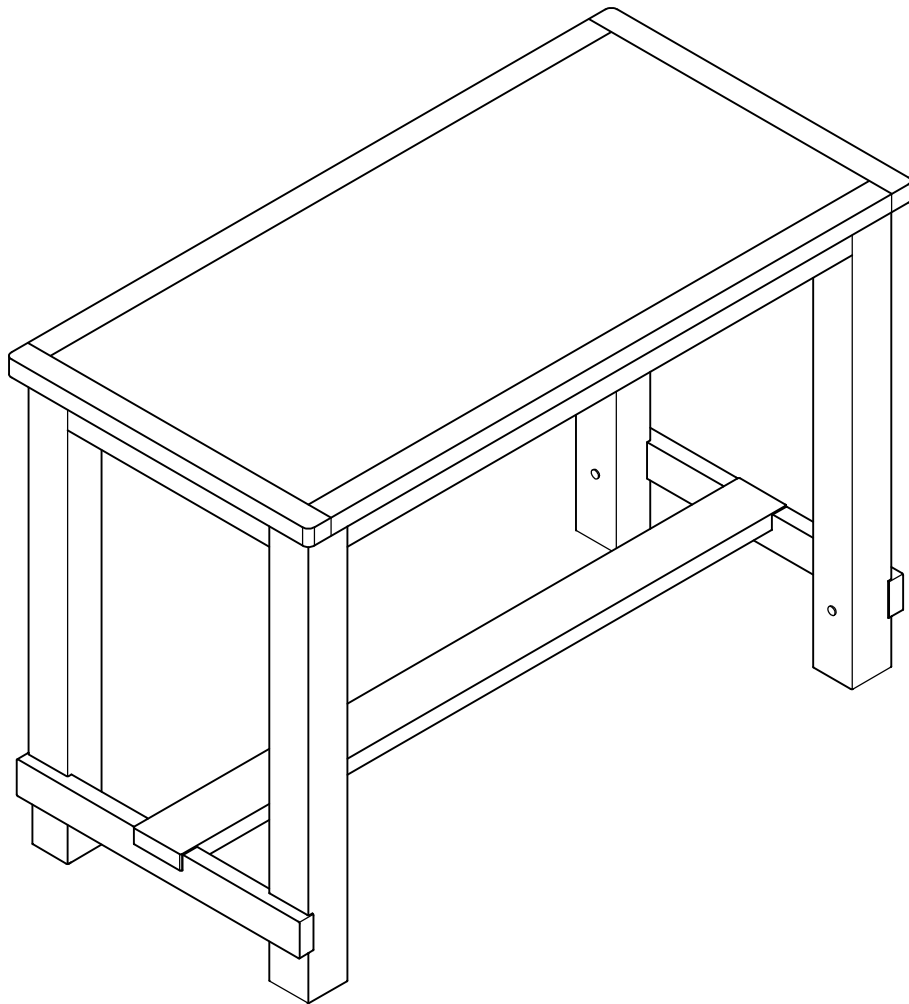

## PARTS LIST

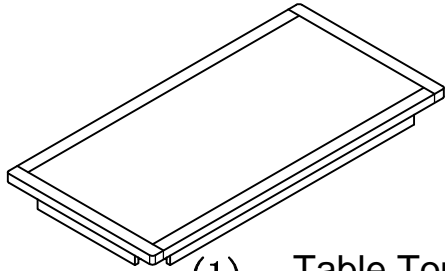

(1) Table Top 1 Pc



(2) Left Leg 2 Pcs



(3) Right Leg 2 Pcs

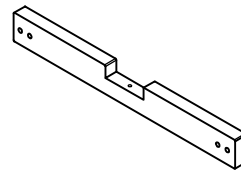

(4) Side Panel 2 Pcs

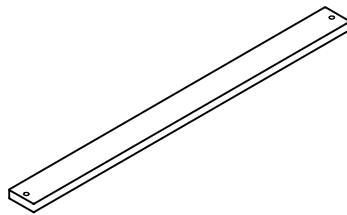

(5) Side Panel Support 1 Pc

## HARDWARE LIST

NO	SKETCH	DESCRIPTION	SIZE	Q' TY
A		Bolt	$\phi 5/16'' \times 2-1/2''$	10 Pcs
B		Bolt	$\phi 5/16'' \times 3''$	4 Pcs
C		Lock Washer	$\phi 5/16''$	14 Pcs
D		Flat Washer	$\phi 5/16'' \times 19\text{mm}$	14 Pcs
E		Allen Wrench	$\phi 5 \text{ mm}$	1 Pc
F		Wooden Plug	$\phi 23 \times 19\text{mm}$	4 Pcs

# STEP 1

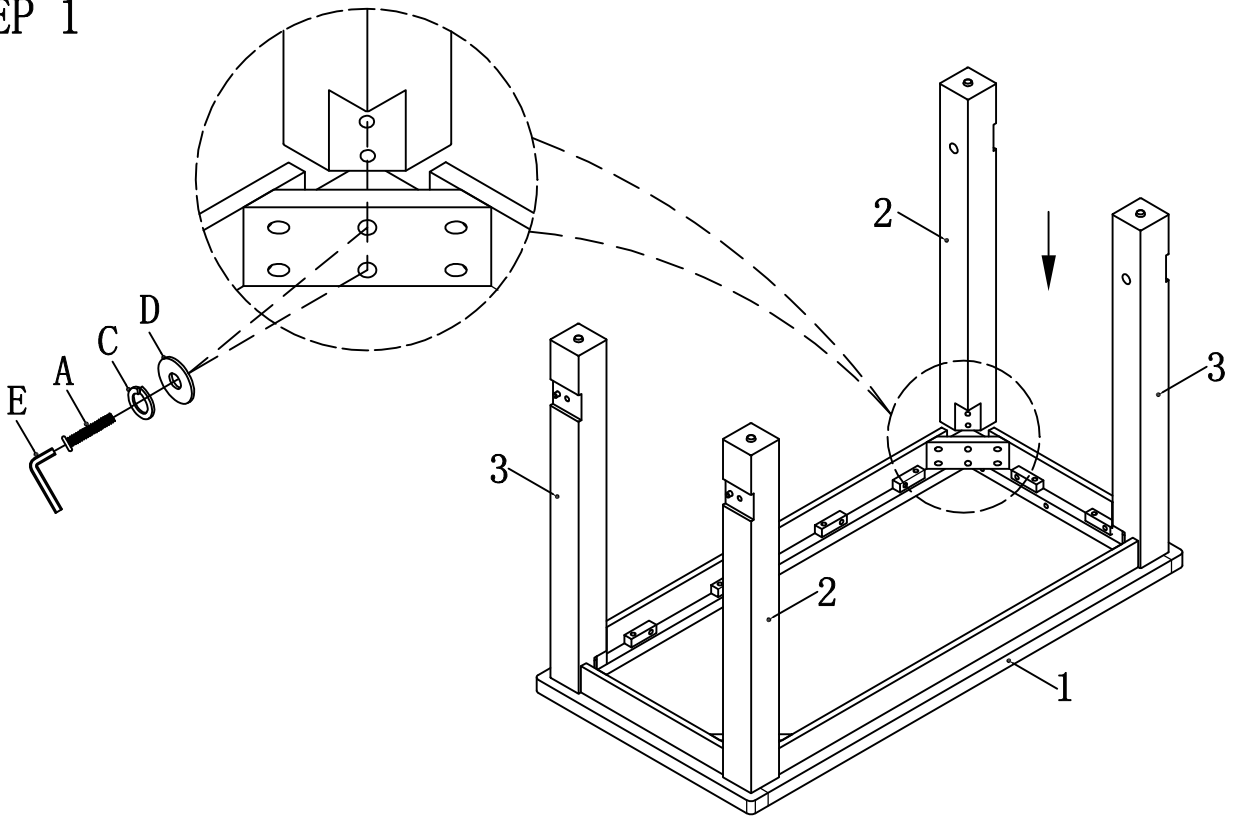

NOTE: Do not fully tighten the bolts in this step.

# STEP 2

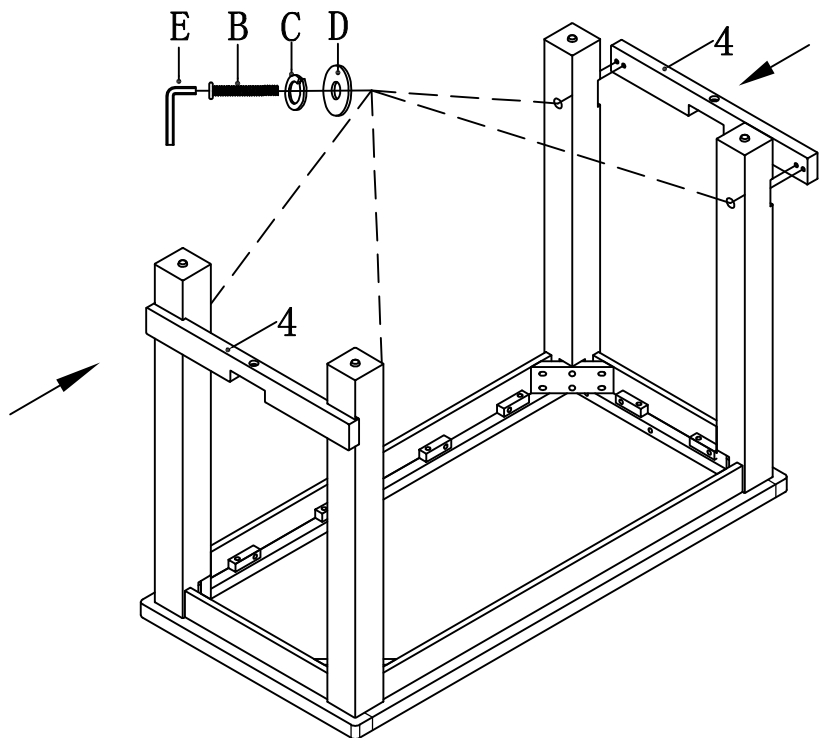

### STEP 3

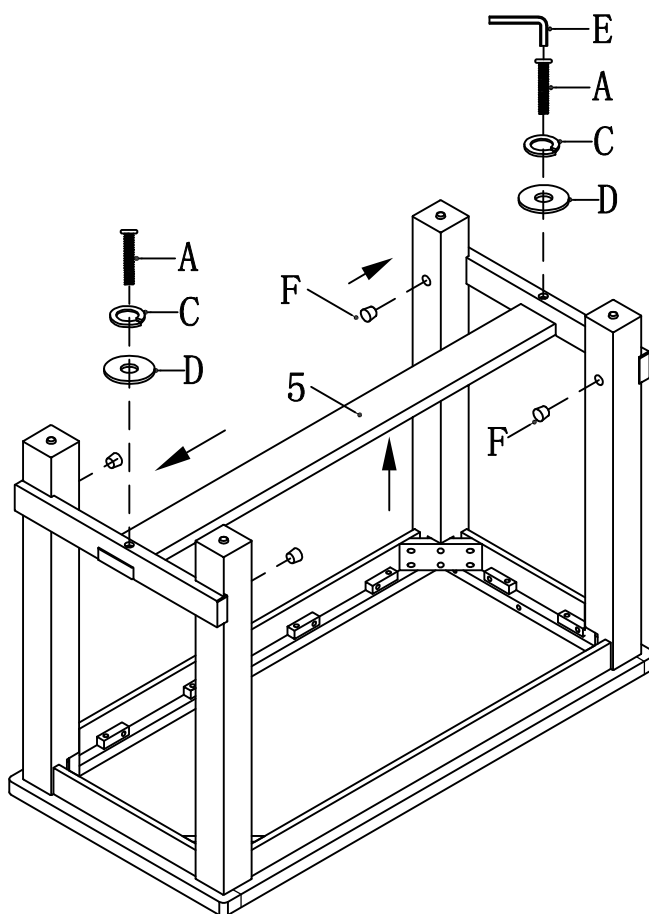

NOTE: Please tighten all the bolts in this step.

### STEP 4

Completed assembly,  
now your table is ready .

