

ASSEMBLY INSTRUCTION

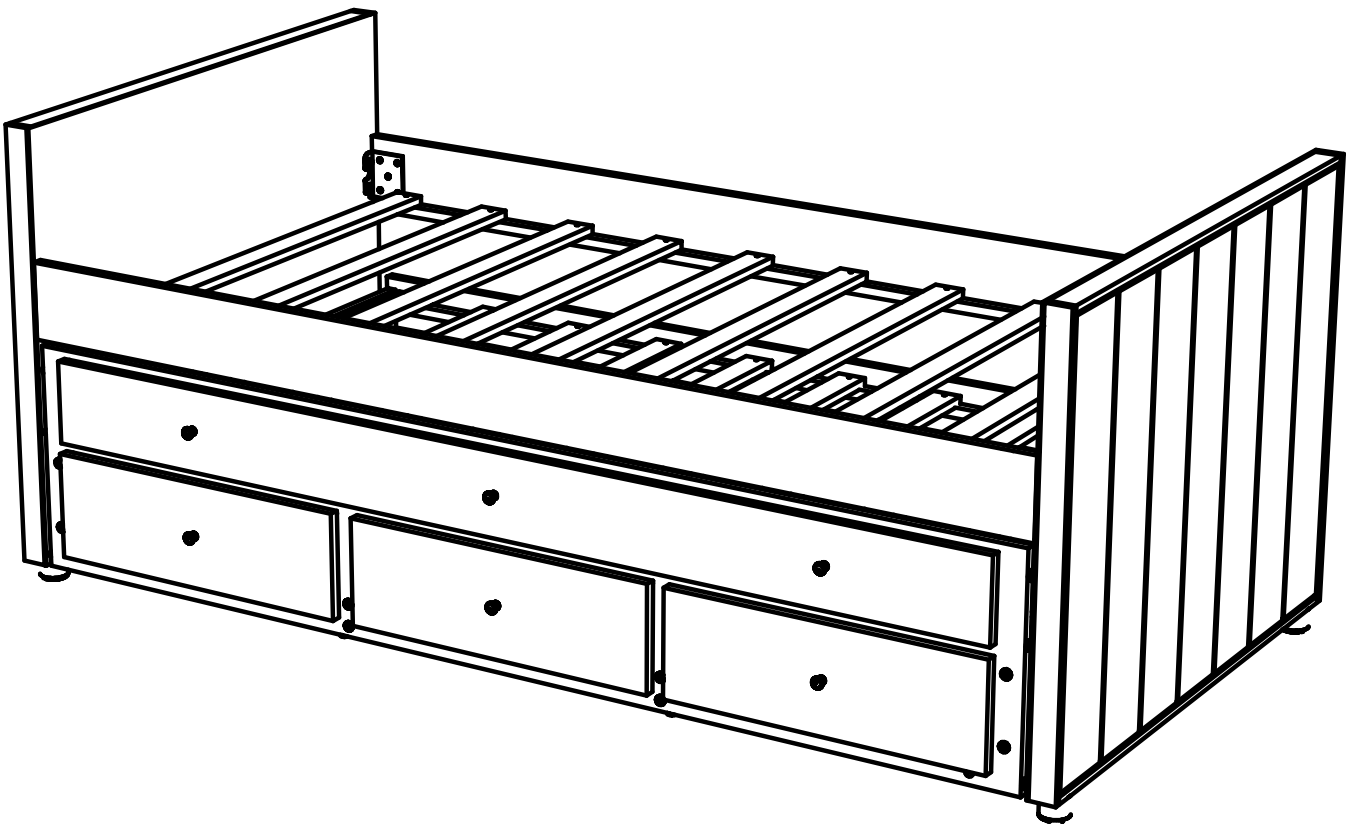

ASSEMBLY INSTRUCTION

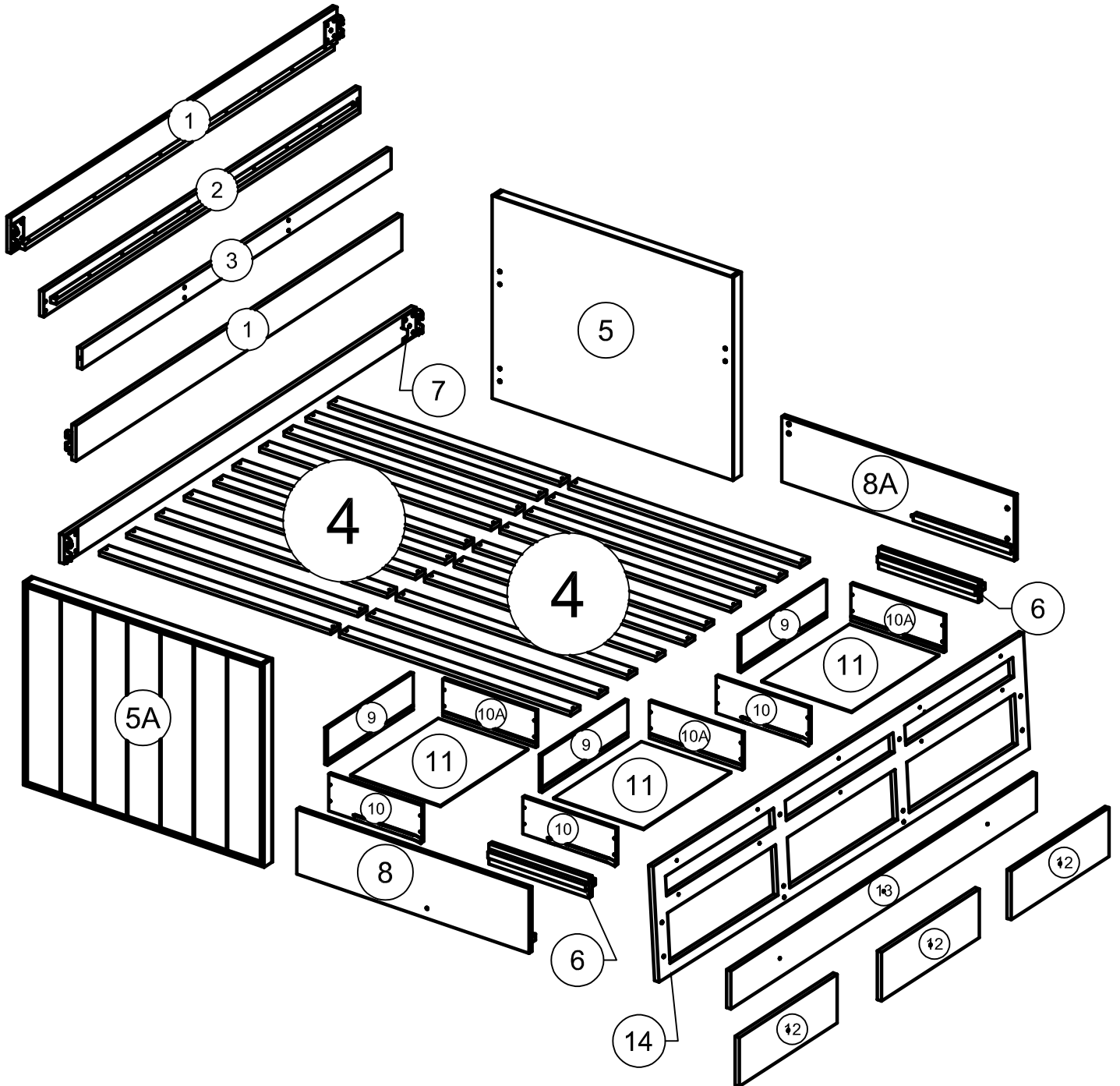

Part List

4



Slats - 20pcs

6

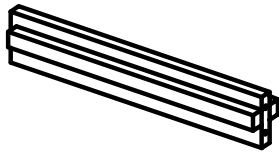

Drawer rail- 2pcs

8

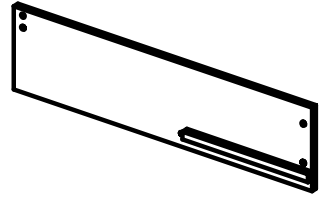

Trundle - Side Rails - 1pcs

8A

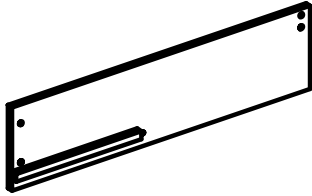

Trundle - Side Rails - 1pcs

9

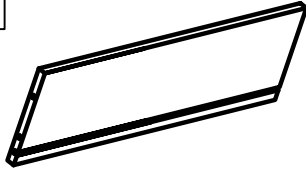

Drawers - Back Panel - 3pcs

10

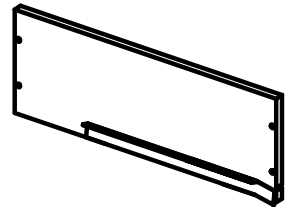

Drawers - Side Panel - 3pcs

10A

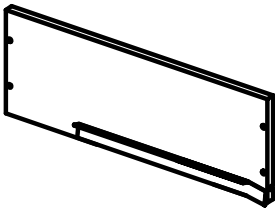

Drawers - Side Panel - 3pcs

12

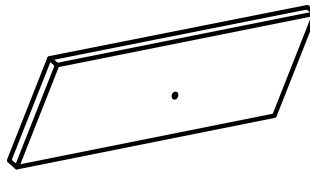

Drawers - Font Panel - 3pcs

Part List

5

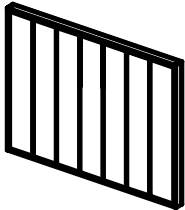

Footboard - 1pc

5A



Headboard - 1pc

Part List

1

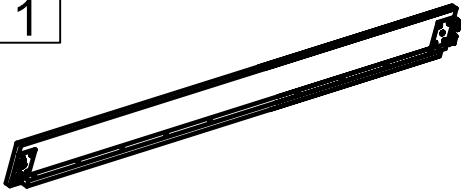

Side Rails - 2pcs

2



Side Rails - 1pc

3



Crossbar - 1pc

7



Side Rails - 1pc

11

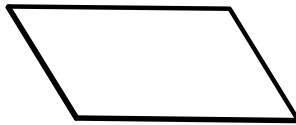

Drawers - Bottom Panel - 3pcs

13

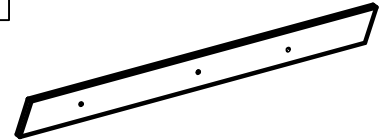





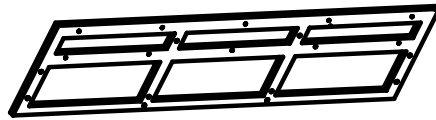





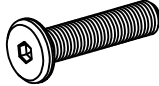

Fake Drawer Surface - 1pc

14

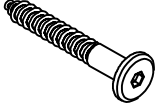
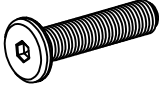

Font Panel - 1pc

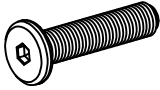
Hardware List

A  Plastic Feet(Ø50x40) 4pcs	B  1/4" x 15mm Horizontal -Hole bolts 10pcs	C  1/4" x 30mm Hex-Head bolts 12pcs
D  Ø8 x 30 mm Wood dowel 2pcs	E  Allen Key 1pcs	F  #4 x 20 mm Wood Screws 8pcs
G  Ø1/4 x 50 mm Wood Screws 8pcs	H  M4 x 45mm Hex-Head bolts 3pcs	I  Pull Button 6 pcs
J  #4 x 30 mm Wood Screws 74pcs	K  1/4" x 60mm Hex-Head bolts 10pcs	L  M4 x 35mm Hex-Head bolts 3pcs
M  Wheels 4psc		

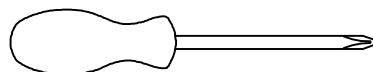

Assembly Tools Required (Not Included)

STEP 1: Following below illustration:

A	
4pcs	

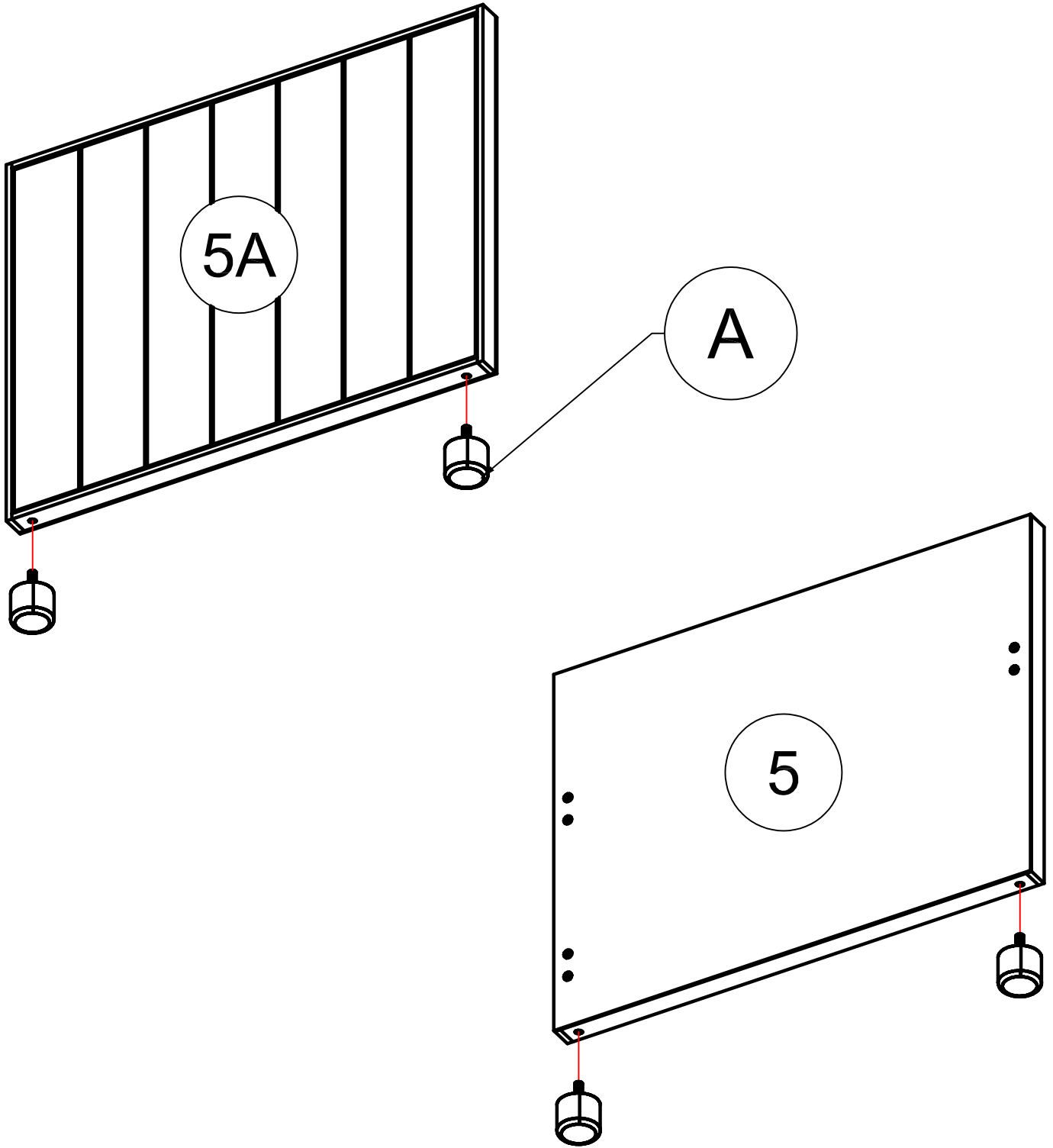

STEP 2: Following below illustration:

C



12pcs

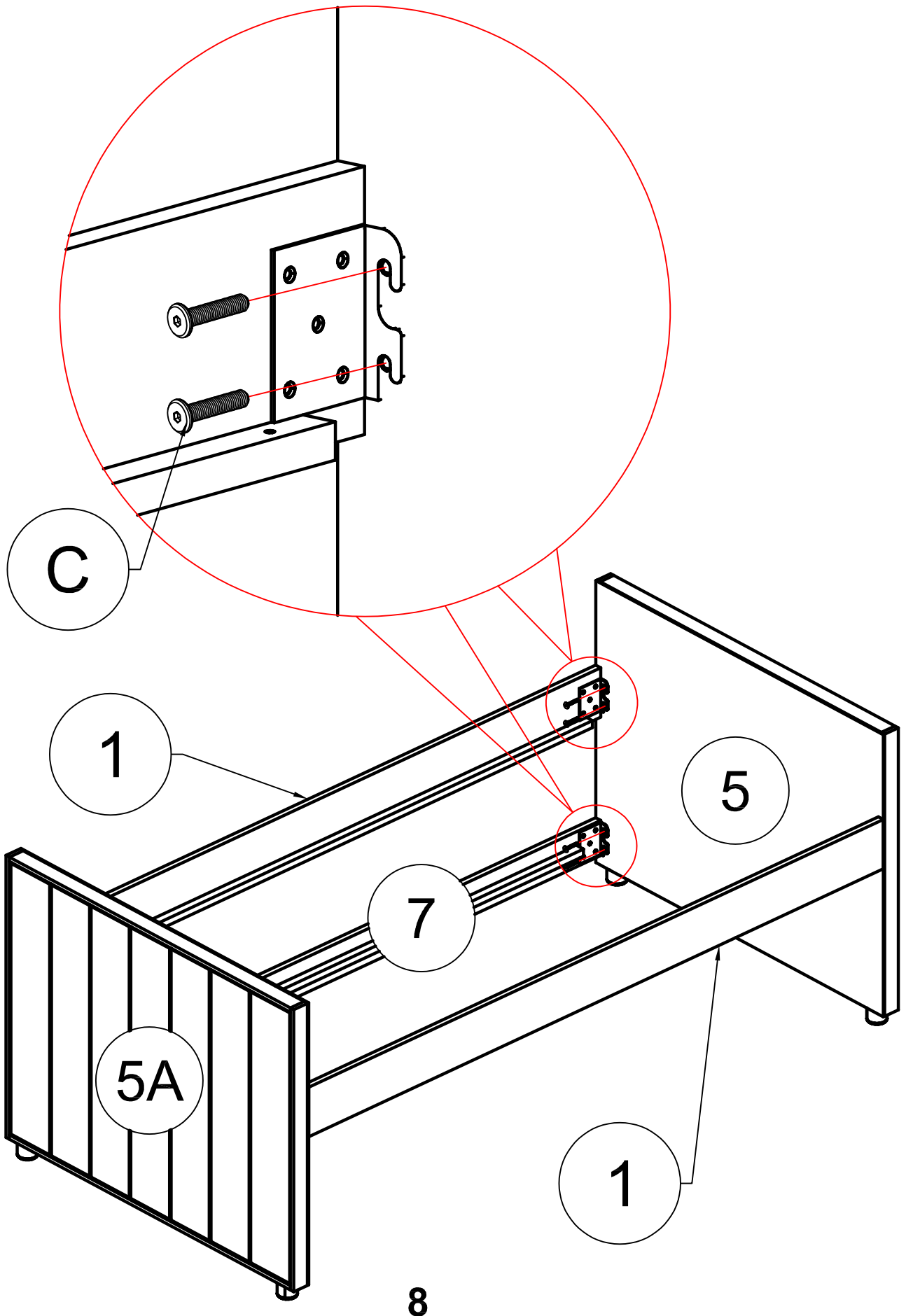

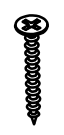

STEP 3: Following below illustration:

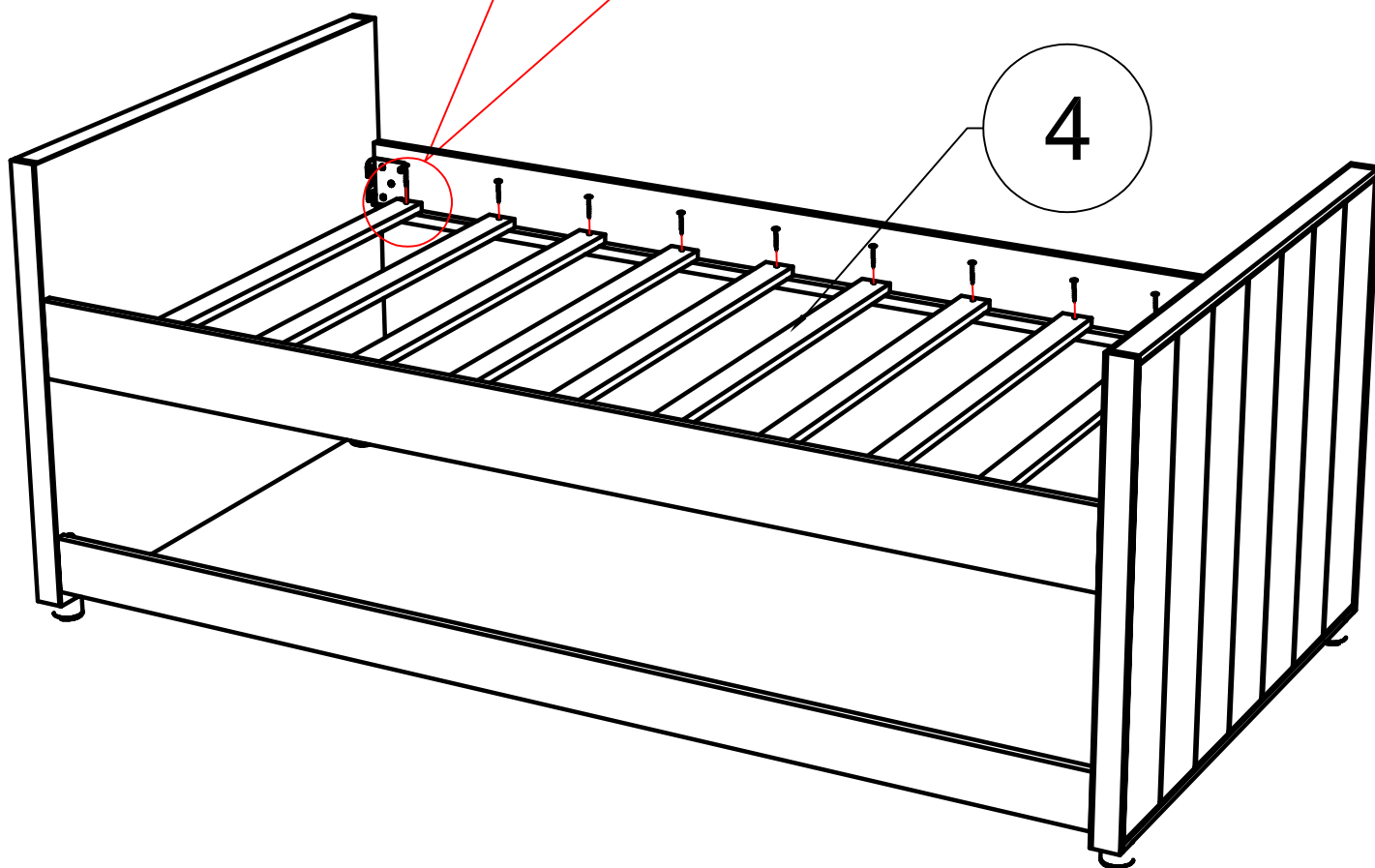
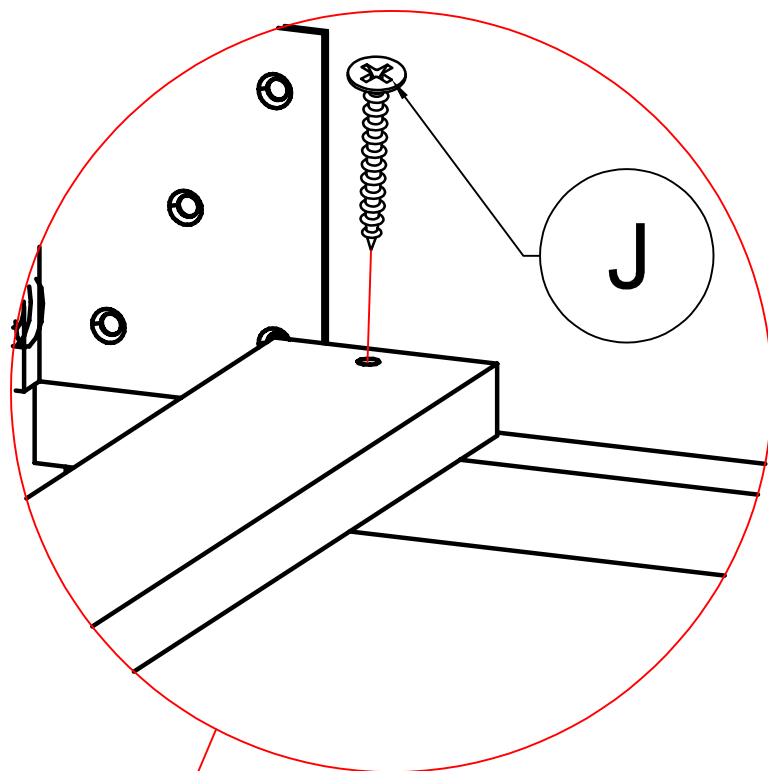
J

20pcs



STEP 4: Following below illustration:

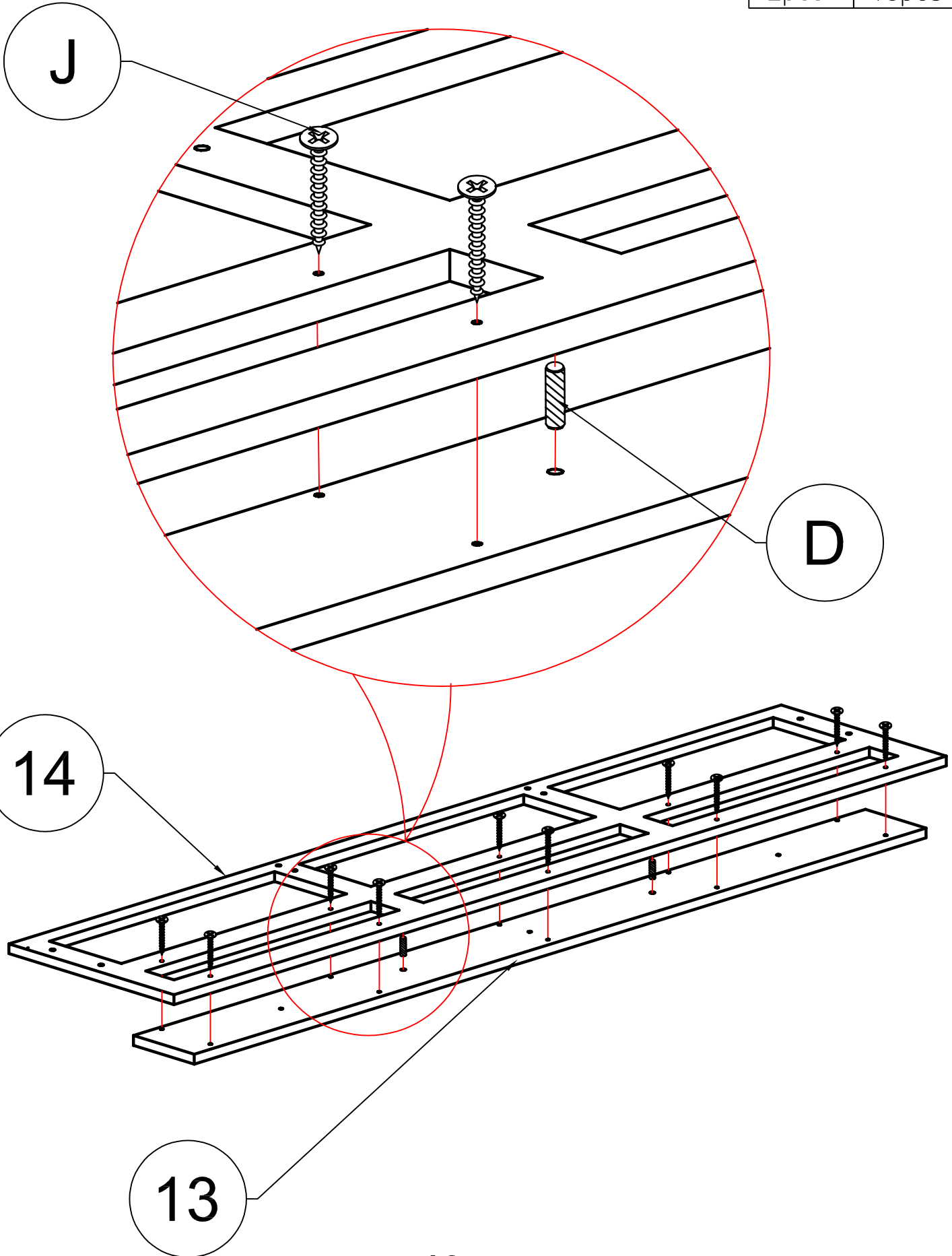

D	J
	
2pcs	10pcs

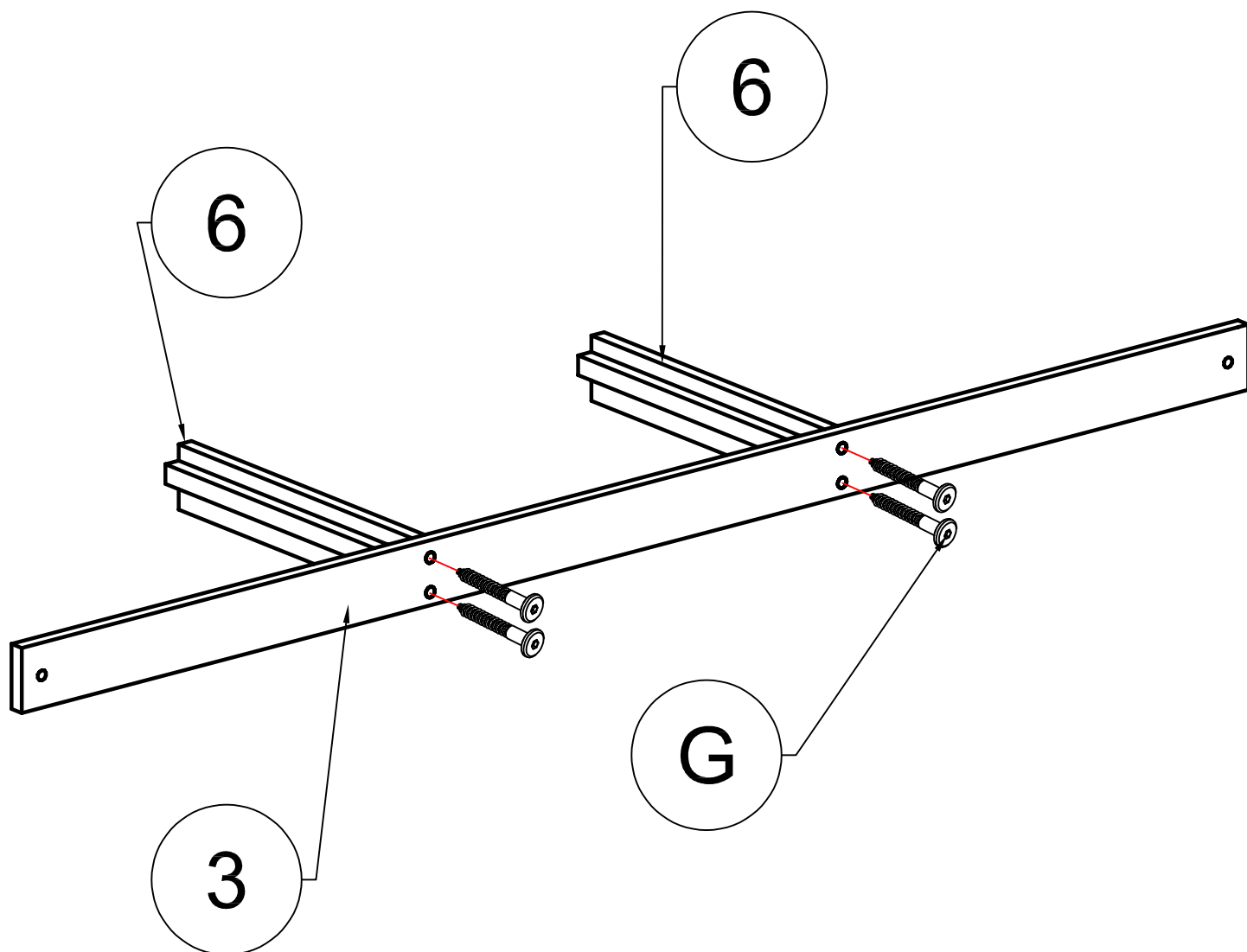
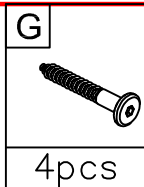

STEP 5: Following below illustration:



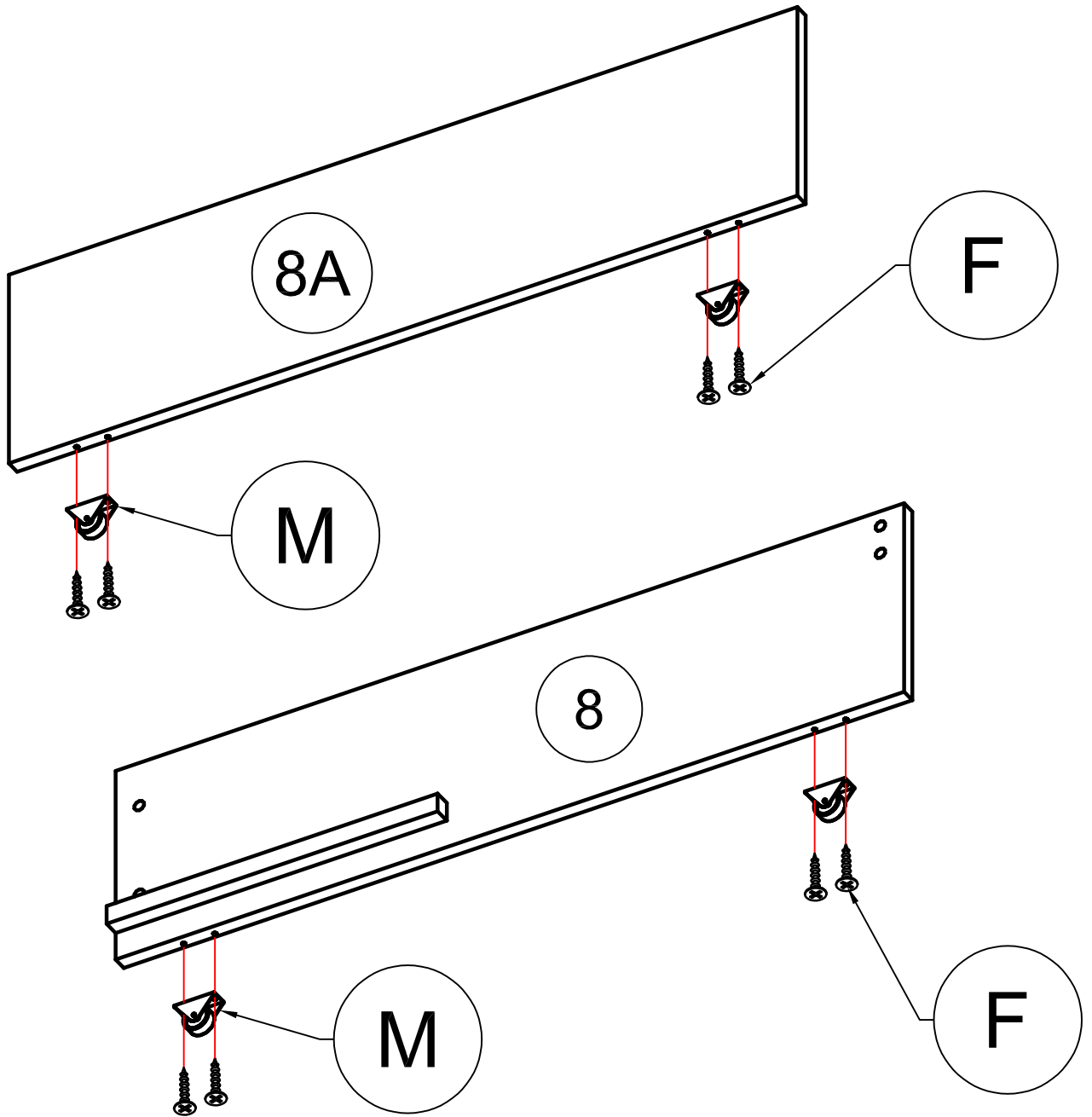

STEP 6: Following below illustration:

M	F
	
4pcs	8pcs



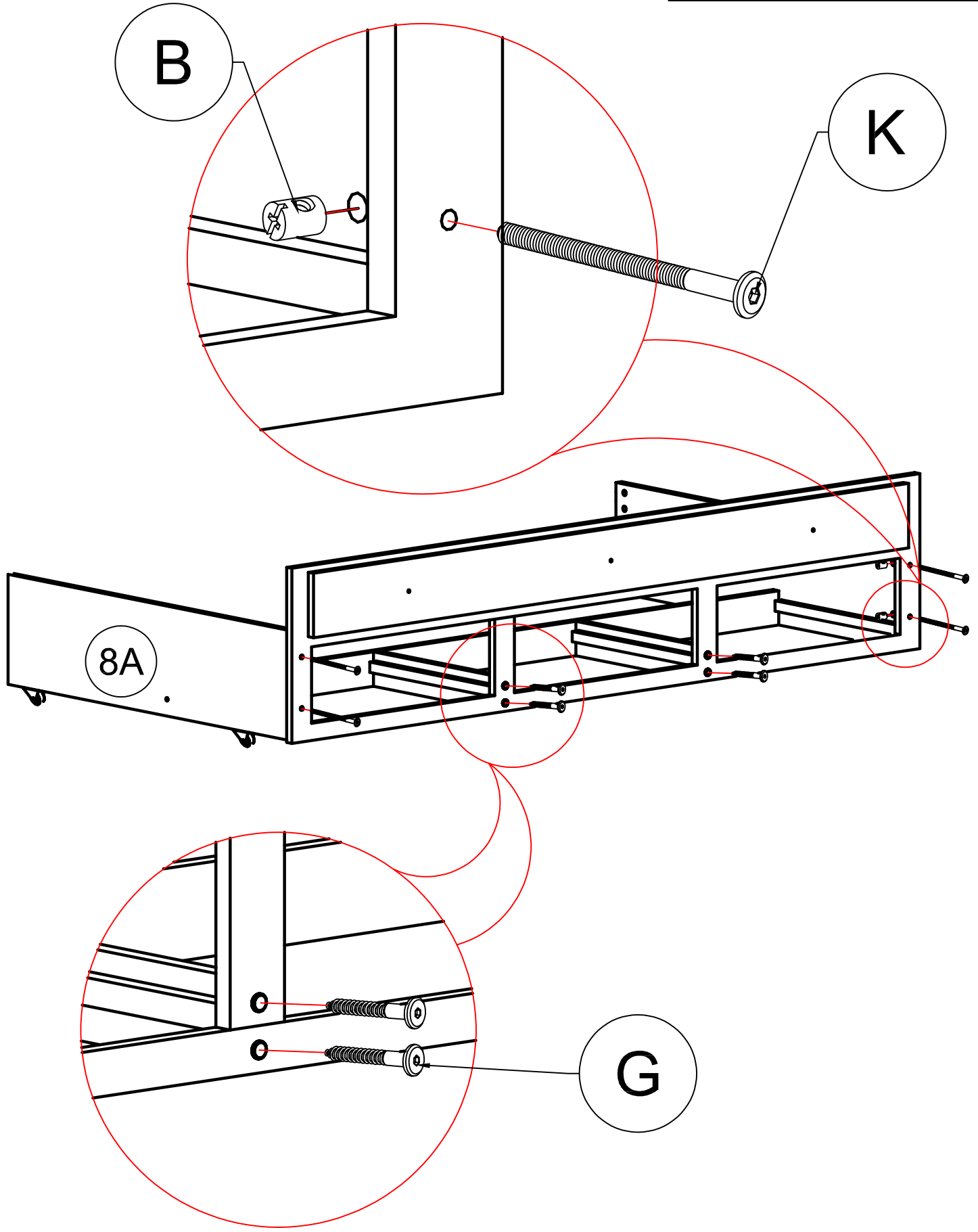

STEP 7: Following below illustration:

K 	B 	G 
4pcs	4pcs	4pcs



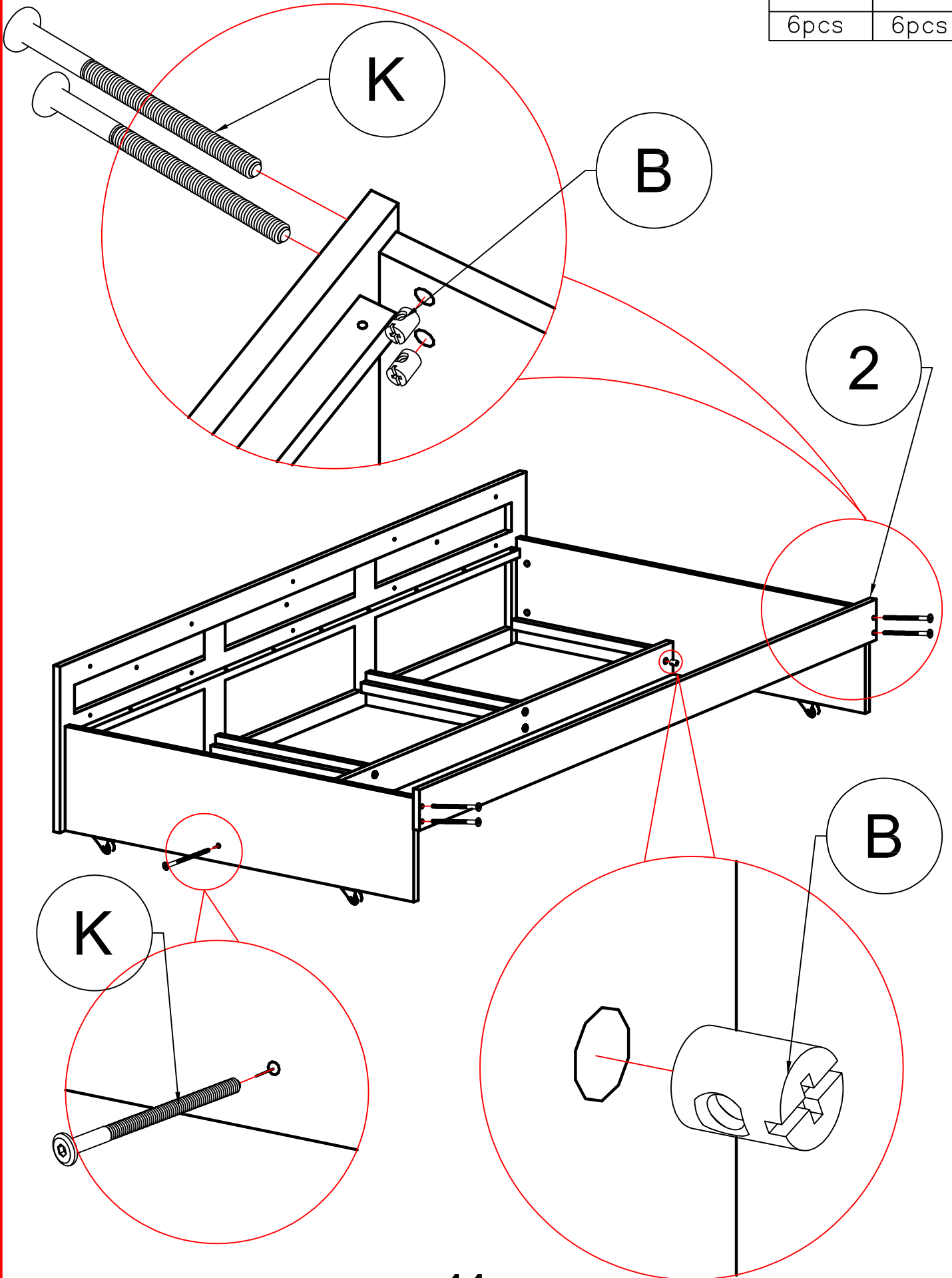

STEP 8: Following below illustration:

K	B
	
6pcs	6pcs

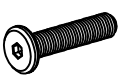

STEP 9: Following below illustration:

L	I
	
3pcs	3pcs

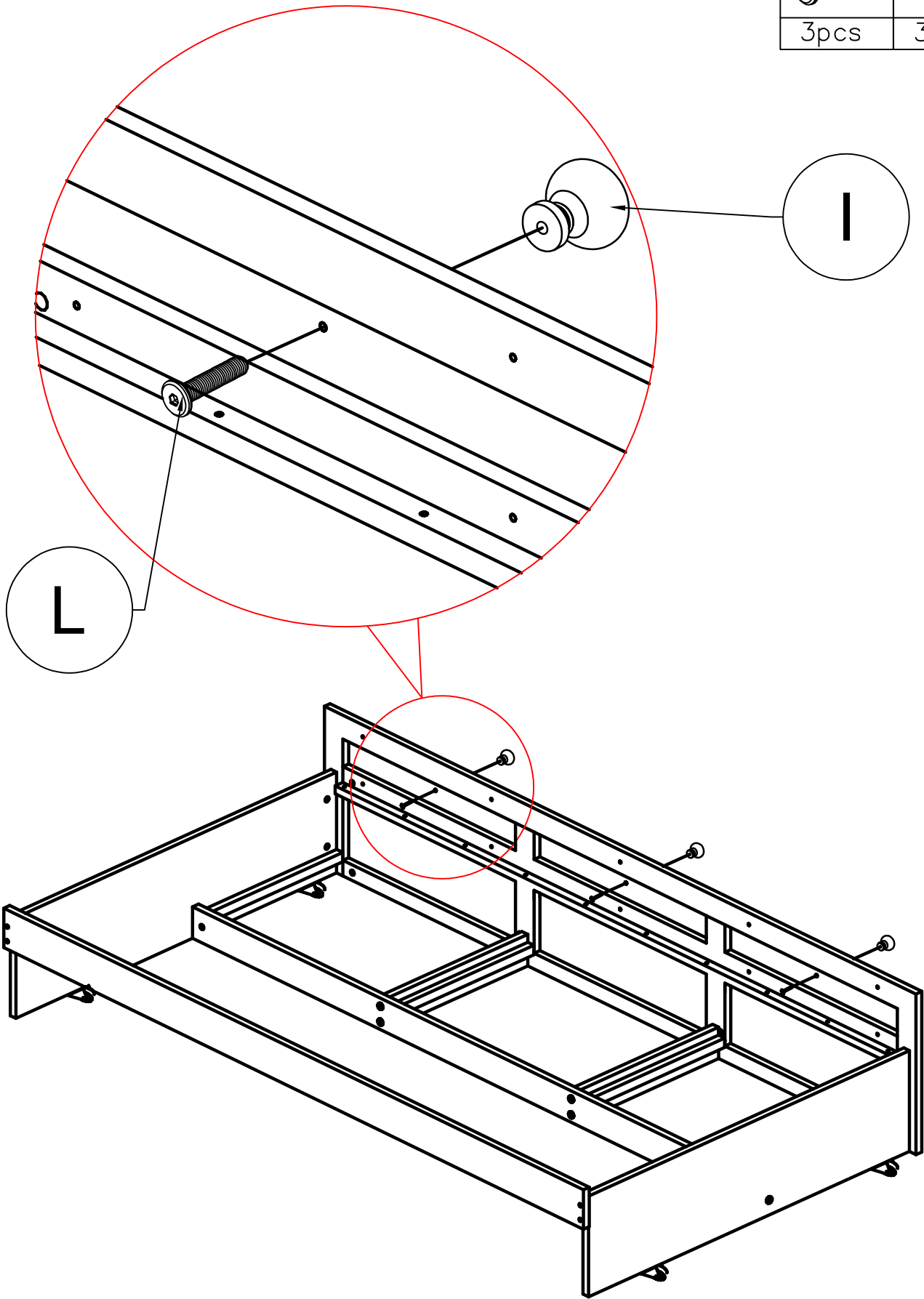

STEP 10: Following below illustration:

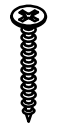
J	
20pcs	

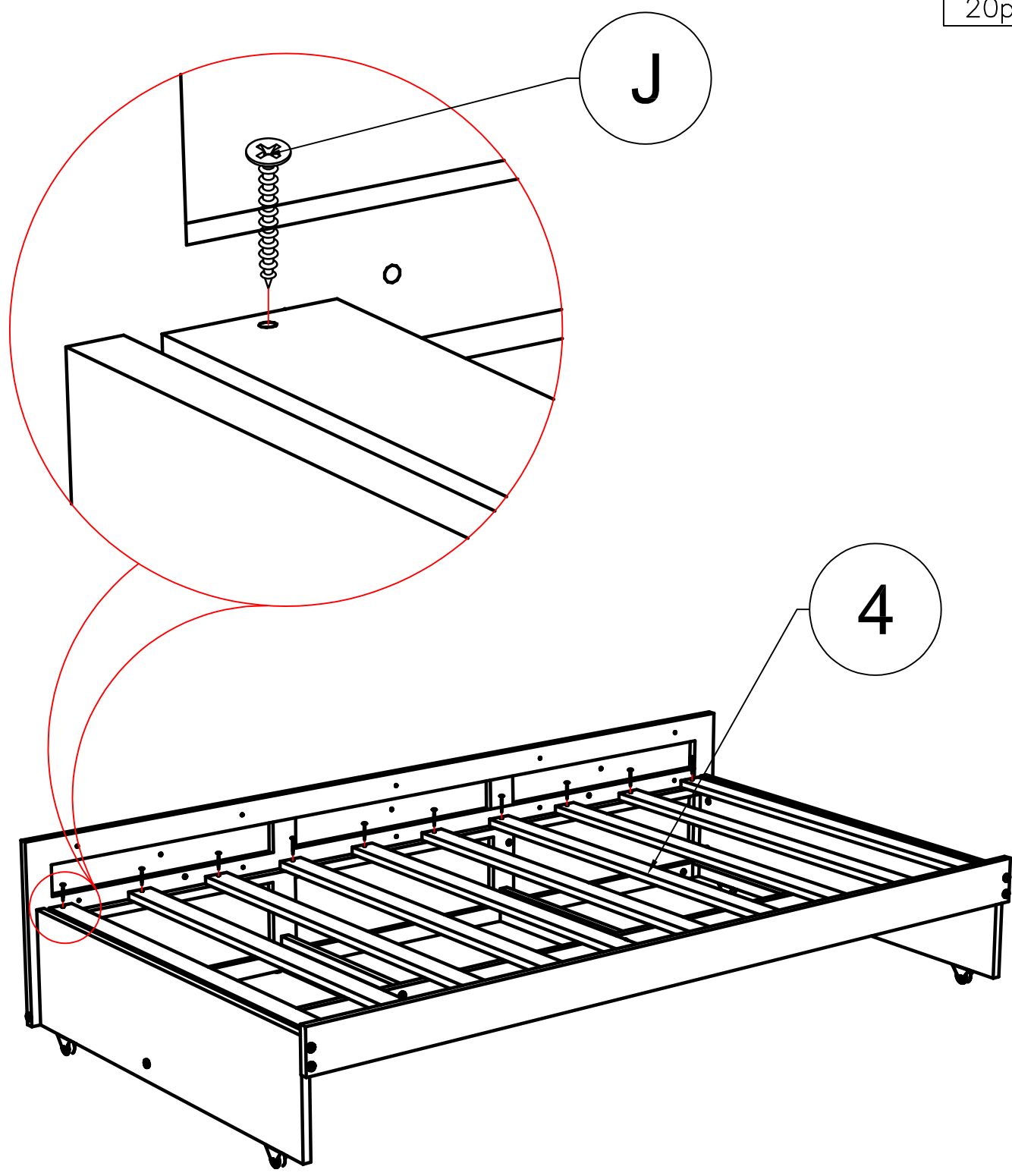

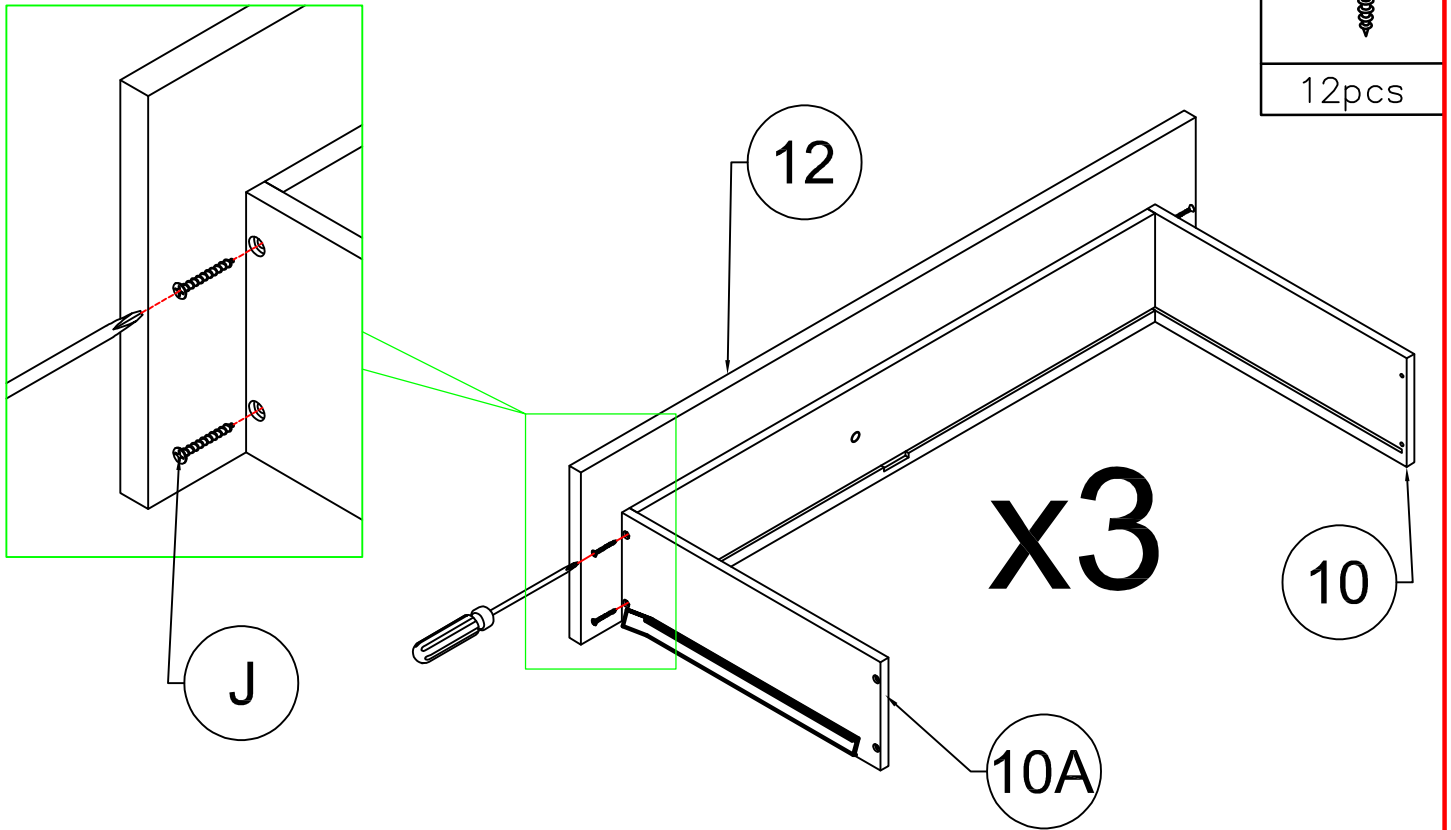

STEP 11: Following below illustration:

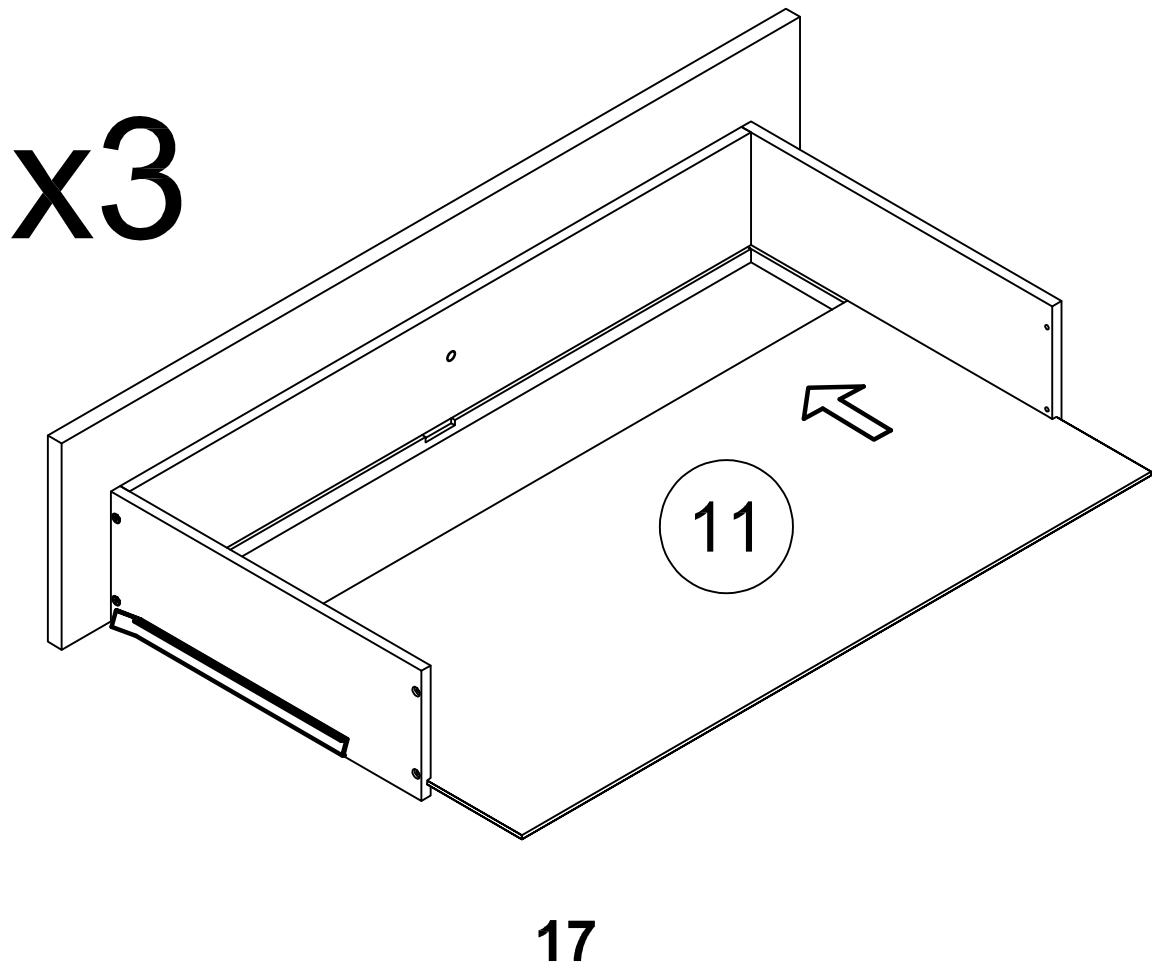

STEP 11.1: Following below illustration:



STEP 12: Following below illustration:

I	H	J
		
3pcs	3pcs	12pcs

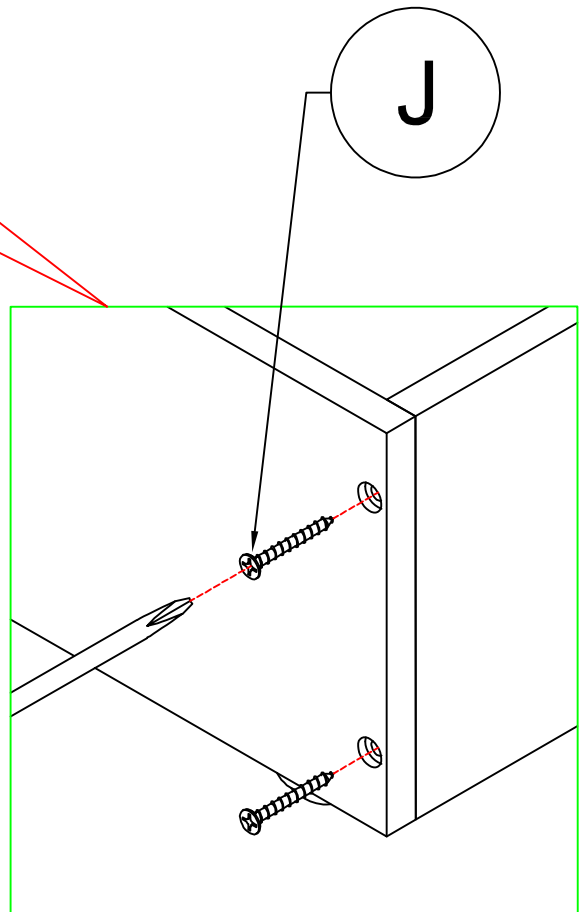
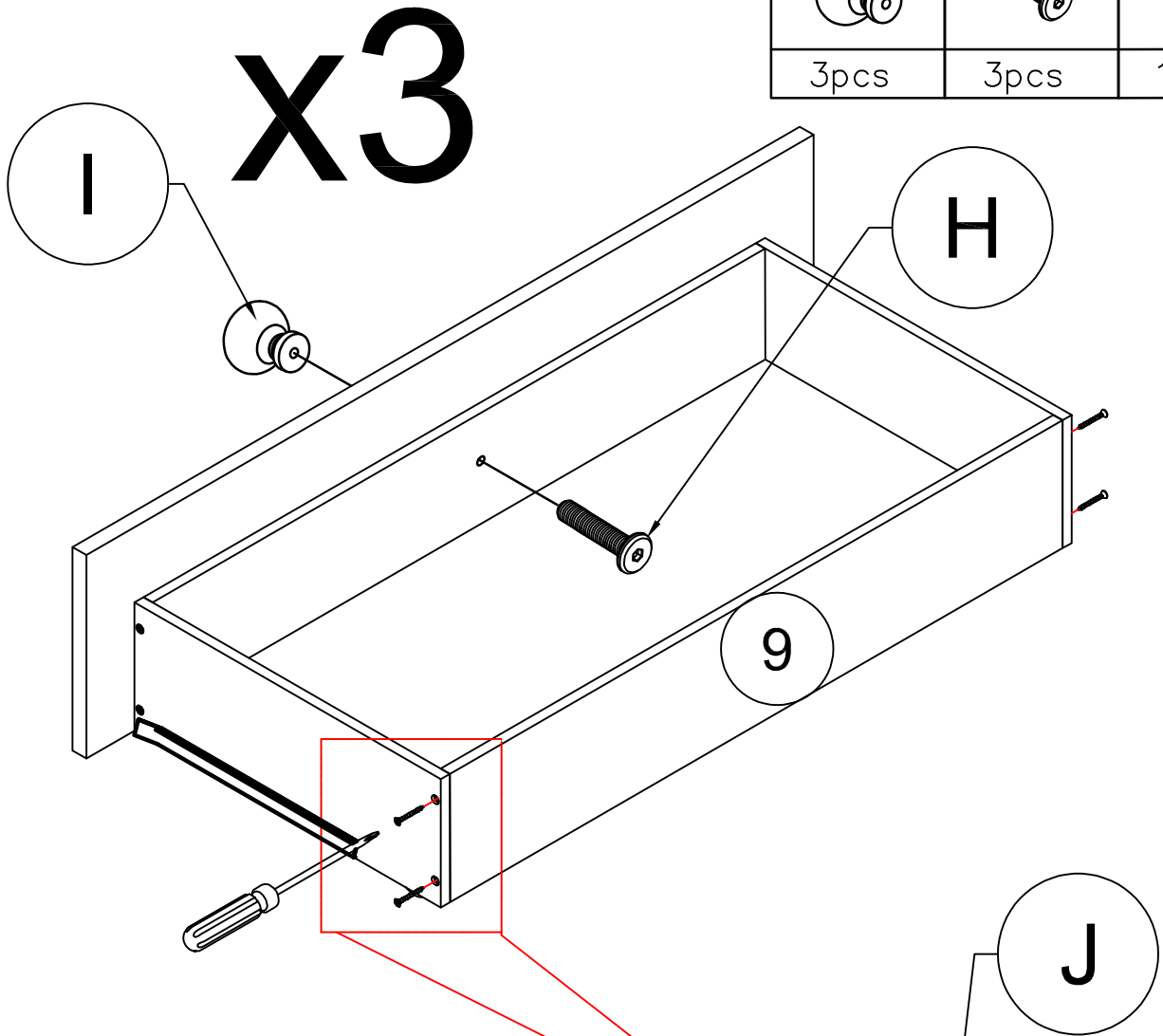

STEP 13: Following below illustration:

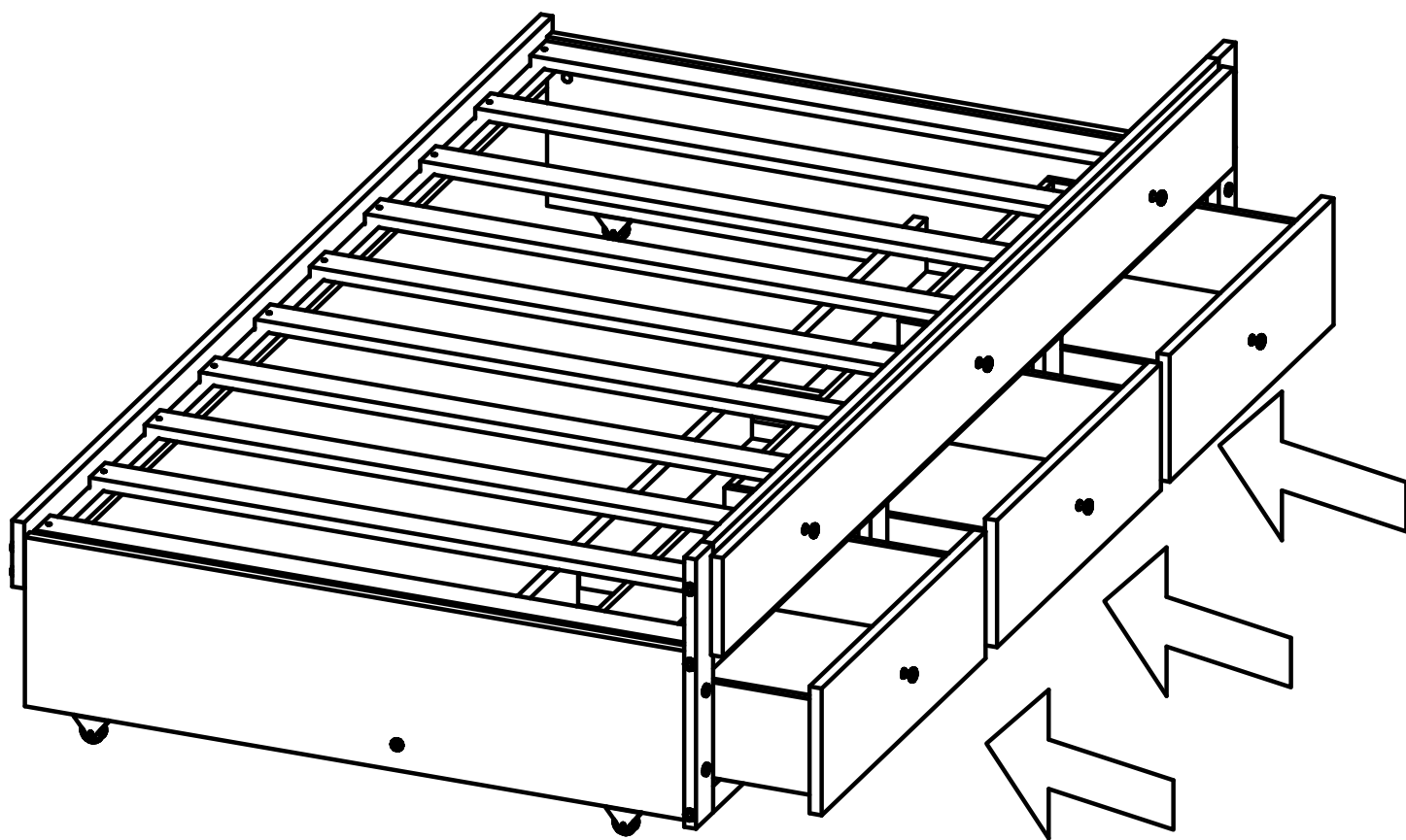

STEP 14: Following below illustration:

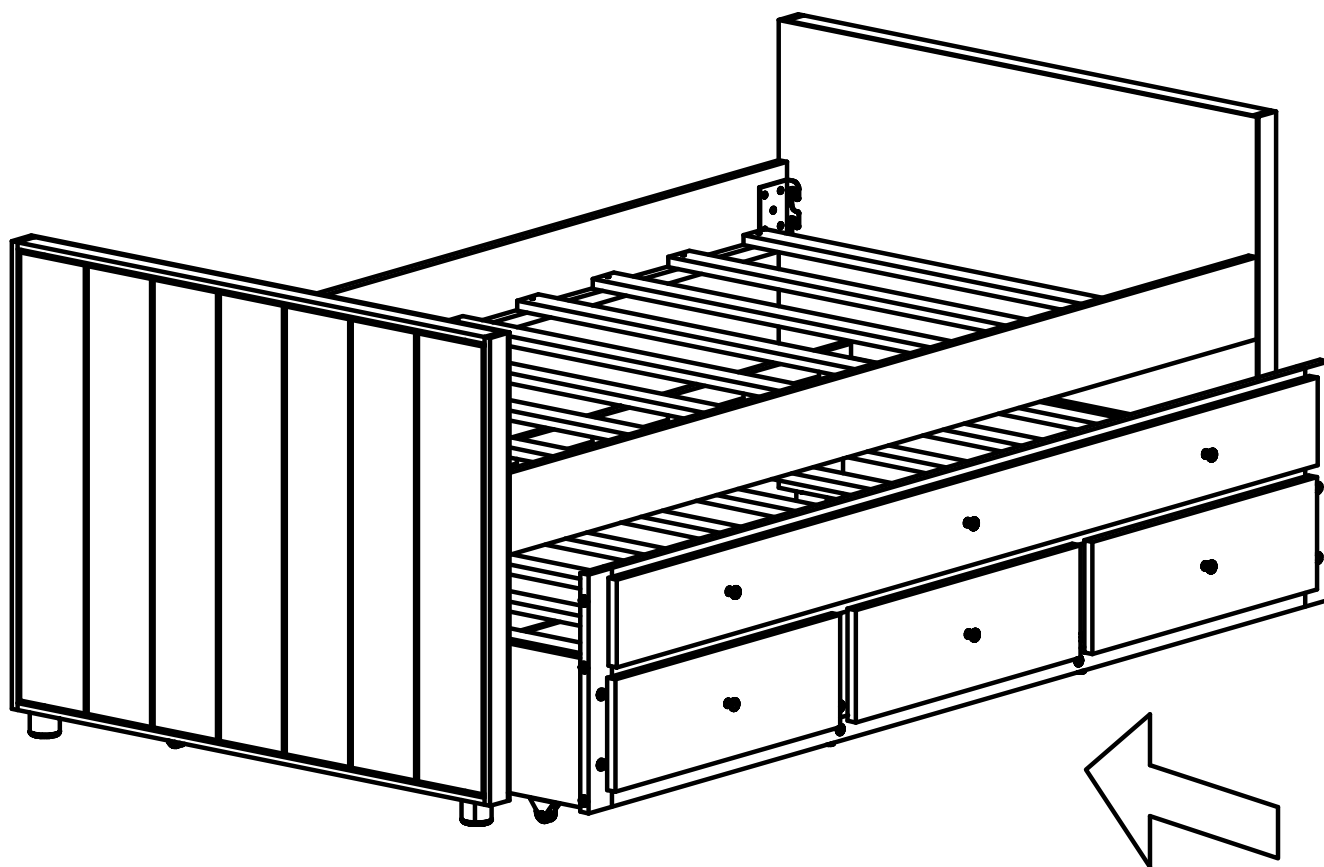

FINISH

