

ASSEMBLY INSTRUCTIONS

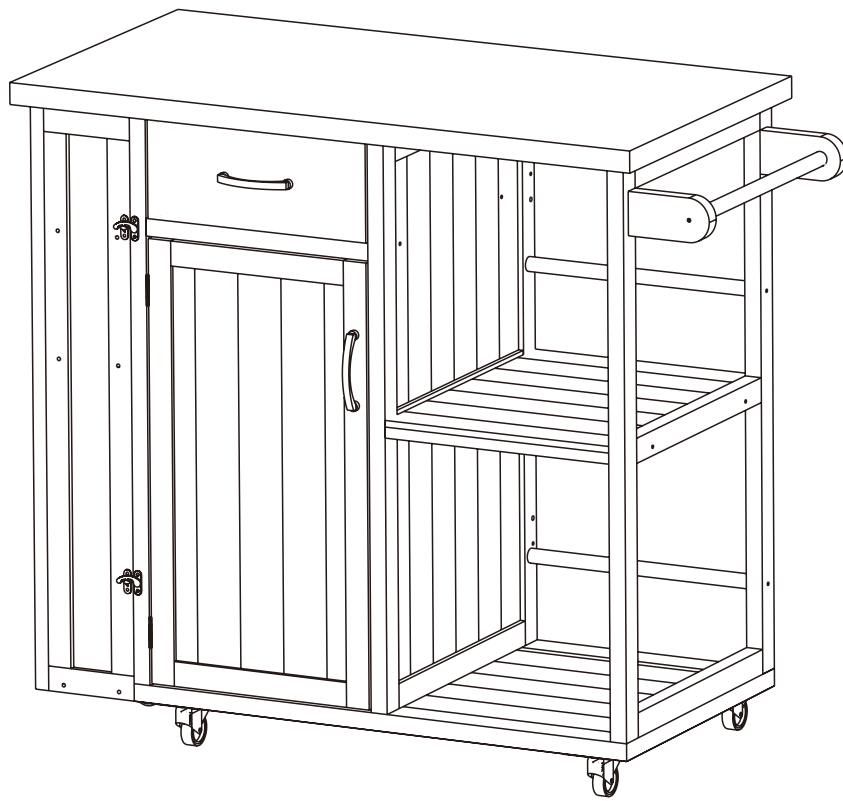







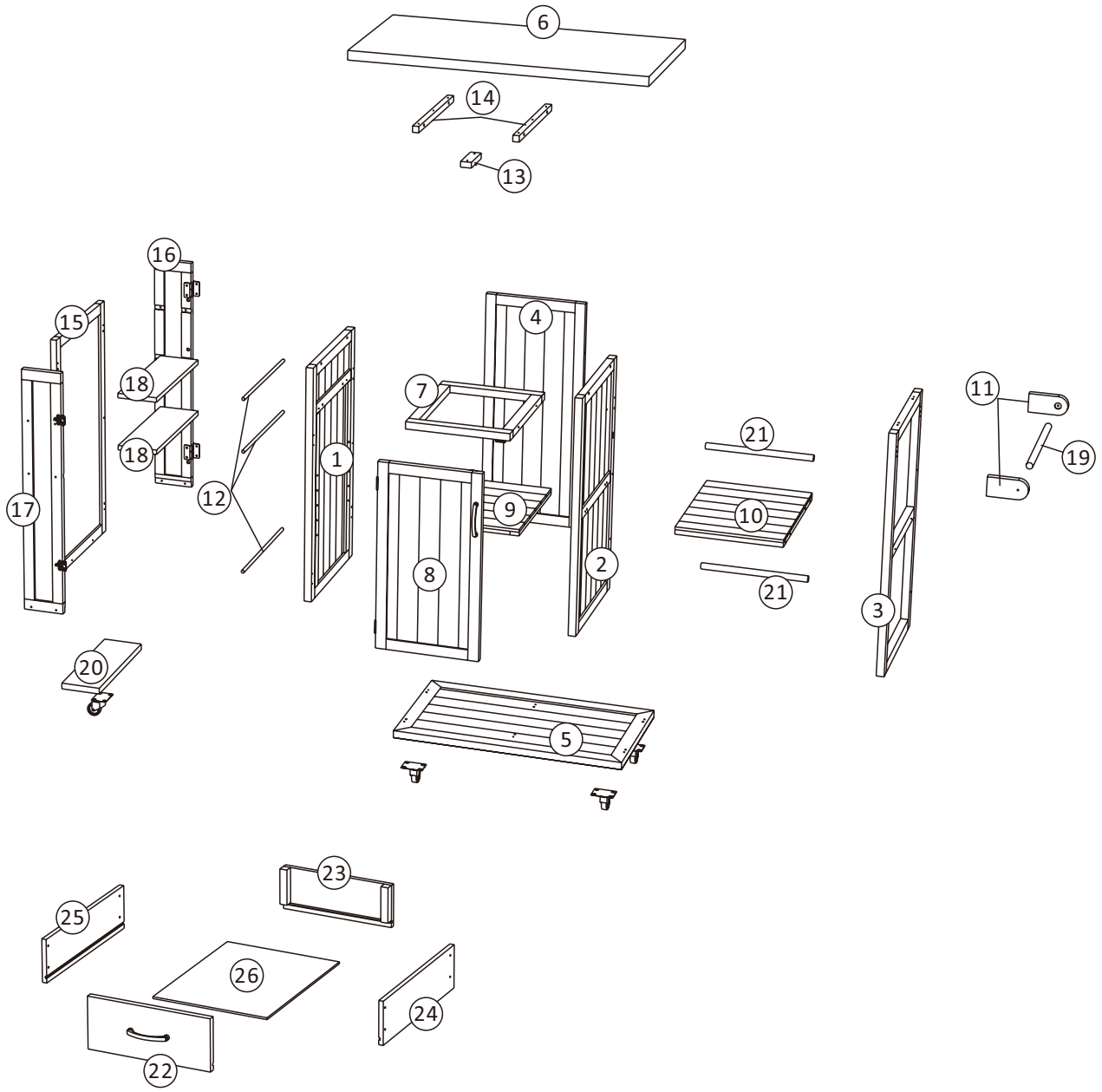

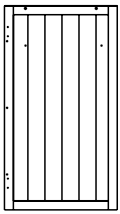
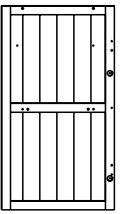
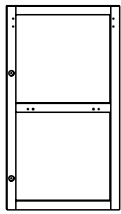
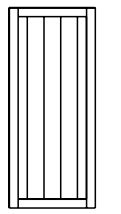
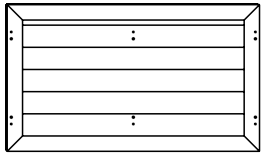
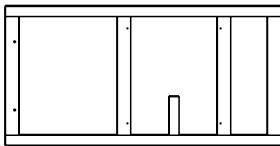
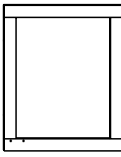
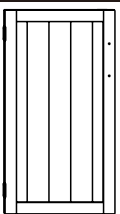
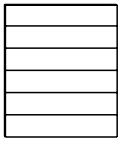
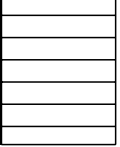

IMPORTANT NOTE:

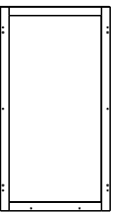

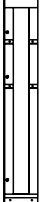
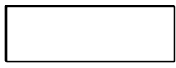
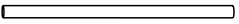
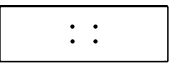
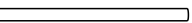
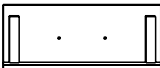

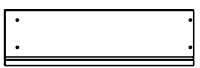











- ① PLACE ALL PARTS ON A CLEAN AND SMOOTH SURFACE SUCH AS A RUG OR CARPET TO AVOID THE PARTS FROM BEING SCRATCHED.
- ② BEFORE YOU BEGIN, KINDLY FOLLOW THE ASSEMBLY INSTRUCTIONS STEP BY STEP.
- ③ DO NOT TIGHTEN ALL SCREWS AND BOLTS UNTIL THIS ITEM IS FULLY SET-UP.

Detail View



1		2		3		4	
	1x		1x		1x		1x
5		6		7		8	
	1x		1x		1x		1x
9		10		11		12	
	1x		1x		2x		3x
13		14		15		16	
	1x		2x		1x		1x
17		18		19		20	
	1x		2x		1x		1x
21		22		23		24	
	2x		1x		1x		1x
25		26					
	1x		1x				

Hardware List

A	 Ø 3.5*60 2x	B	 Ø 3.5*45 23x	C	 Ø 3.5*40 36x	D	 Ø 3.0*28 8x
E	 Ø 3.0*16 19x	F	 Ø 6.0*50 4x	G	 Ø 6.0*20 20x	H	 26x
I	 4x	J	 1x	K	 1x	L	 2x
M	 2x	N	 4x	O	 1x	P	 1x

ASSEMBLY TOOLS REQUIRED(NOT INCLUDED)



PLEASE BE CAREFUL DO NOT DAMAGE THE HOLE POSITION WHEN YOU USE POWERTOOLS !

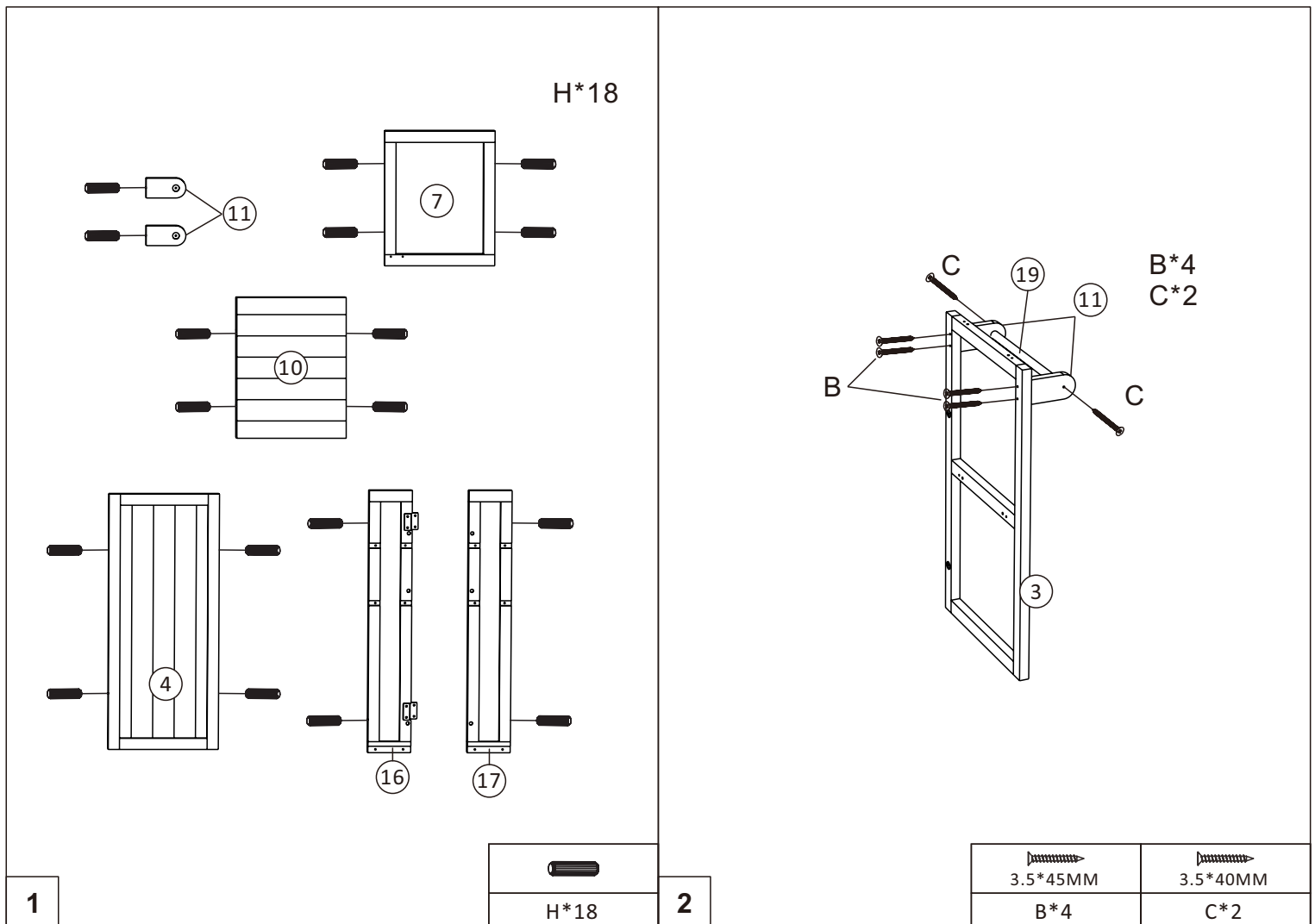

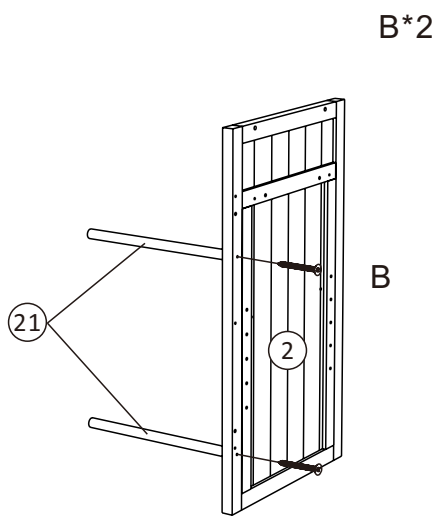



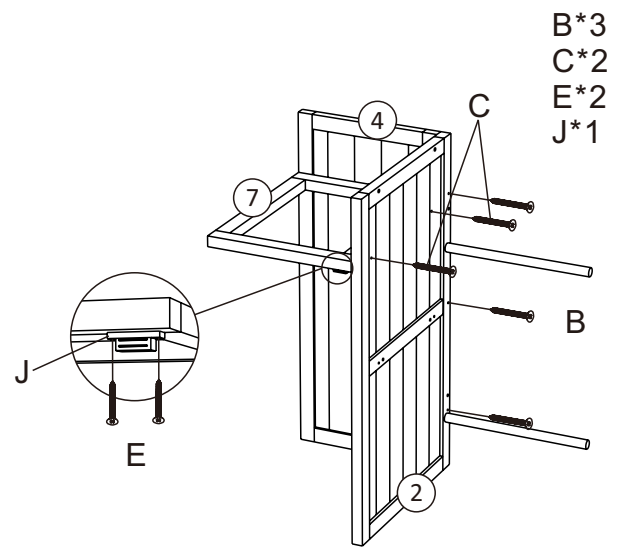

	3.5*45MM
	B*2

3





	3.5*40MM
	C*2

	3.0*16MM
	E*2

	3.5*45MM
	B*3
	
	J*1

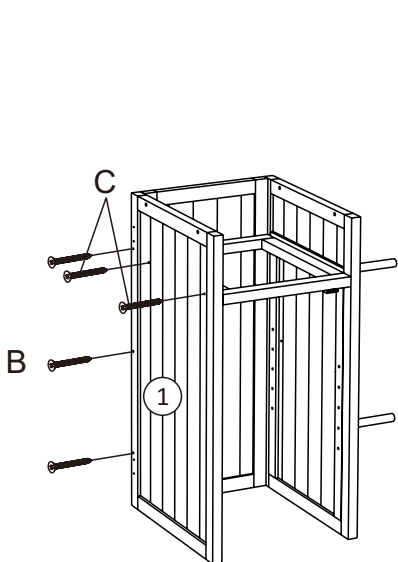
4





	3.5*45MM
	B*3

	3.5*40MM
	C*2

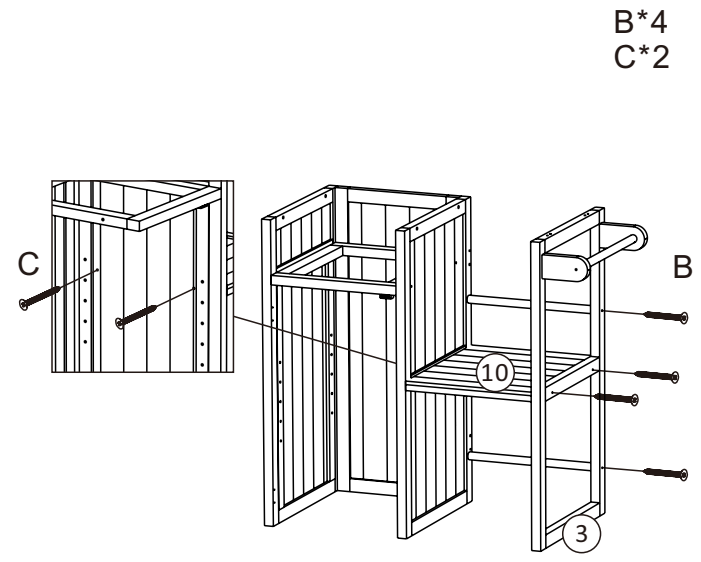
5



	3.5*45MM
	B*4

	3.5*40MM
	C*2

6

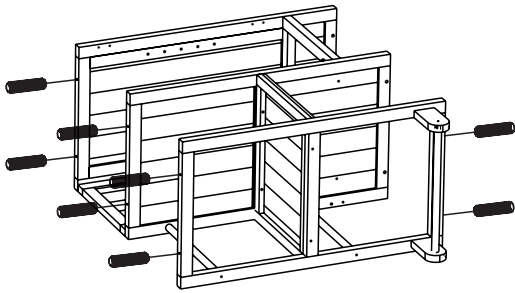

H*8

7



H*8

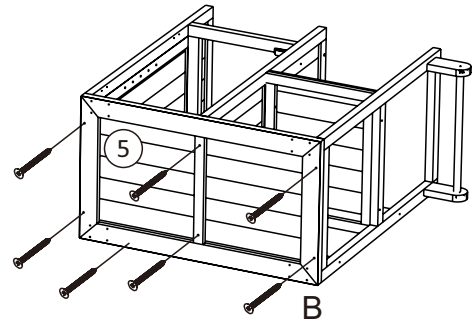

B*7

8

3.5*45MM

B*7

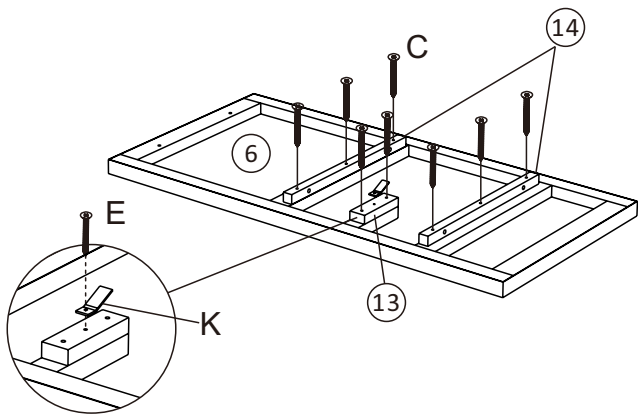

C*8
E*1
K*1

9

3.5*40MM

C*8

3.0*16MM

E*1



K*1

10

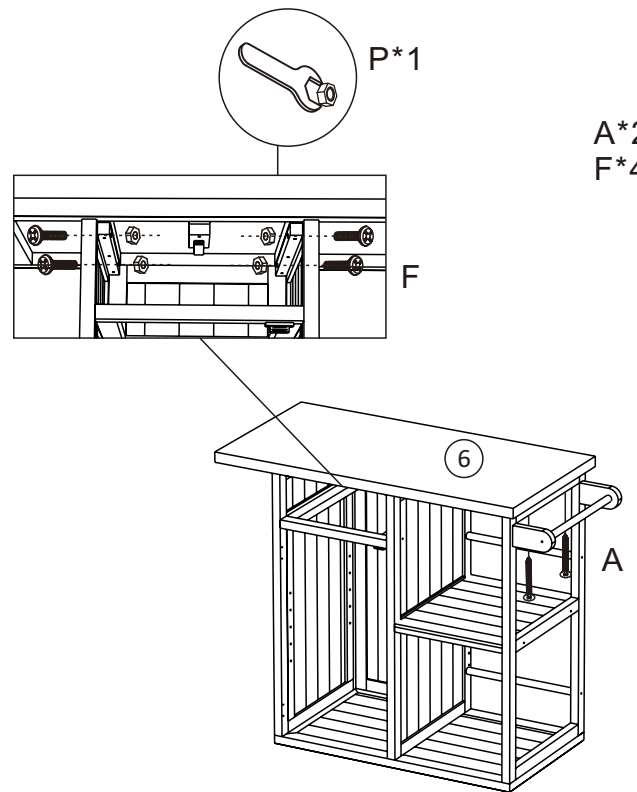

A*2
F*4

3.5*60MM

A*2

6.0*50MM

F*4



P*1

I*4

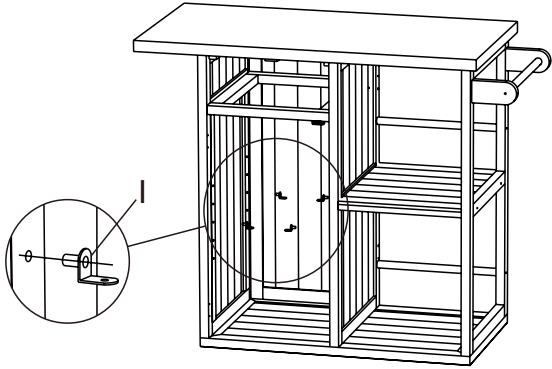

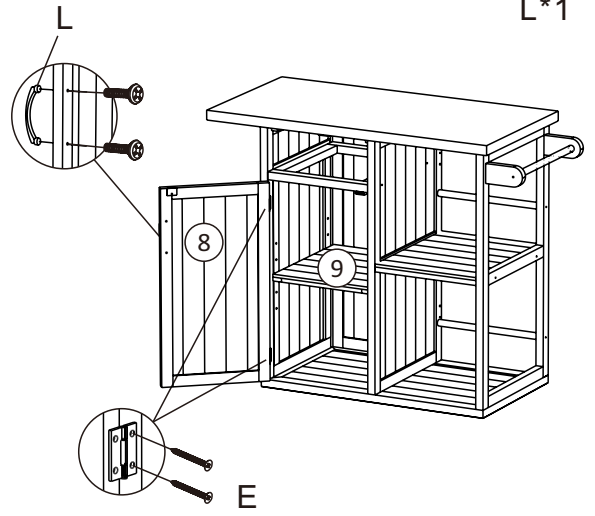

E*4
L*1



11

I*4

12

	
3.0*16MM	E*4
E*4	L*1

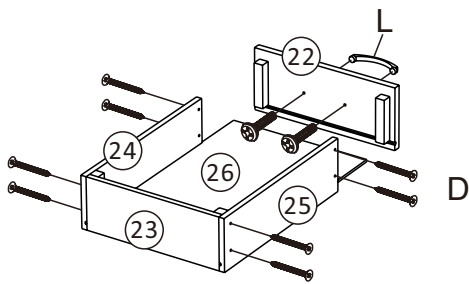

D*8
L*1

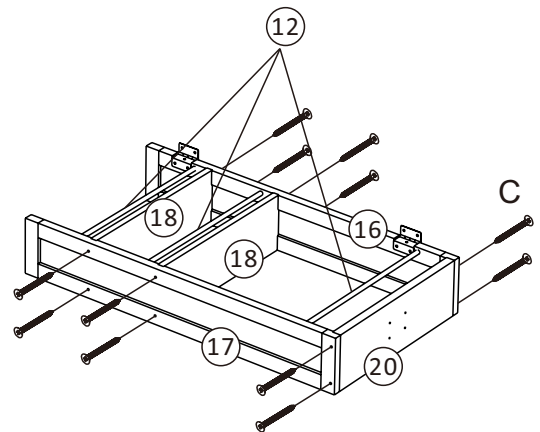

C*12



13

	
3.0*28MM	D*8
D*8	L*1

14

3.5*40MM
C*12

C*8

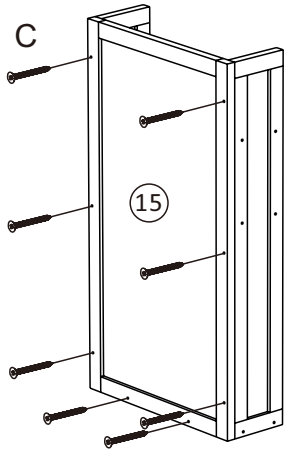

E*4

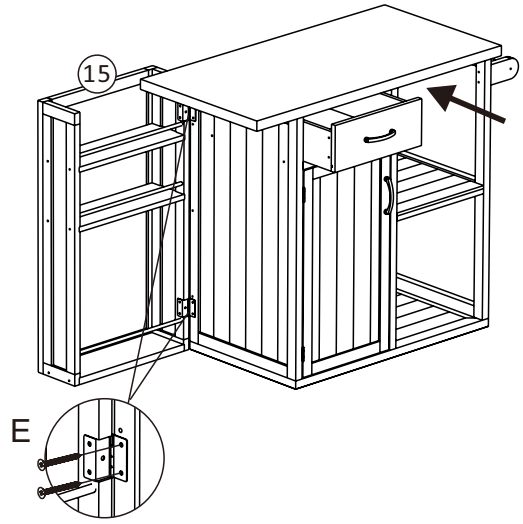

15

3.5*40MM
C*8

16

3.0*16MM
E*4

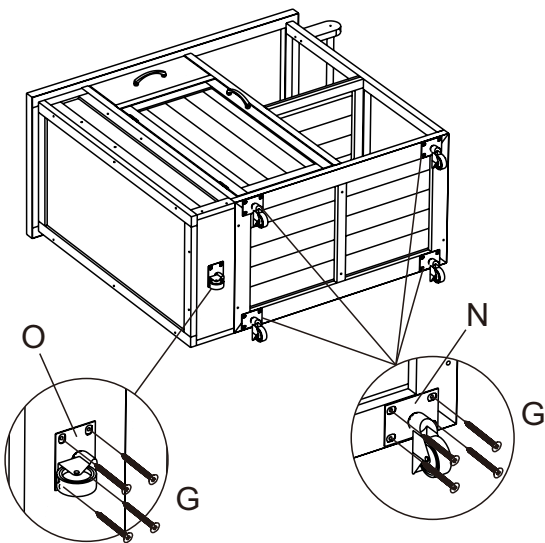

G*20
N*4
O*1



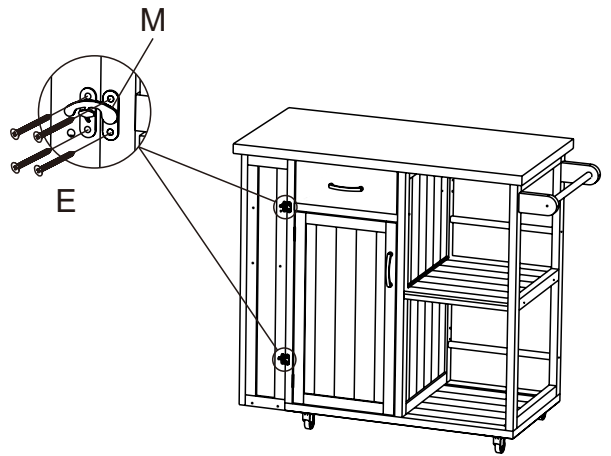

E*8
M*2



17

		
6.0*20MM		
G*20	N*4	O*1

18

	
3.0*16MM	
E*8	M*2