

Assembly Instructions

Caution: You must read this before you process

TABLE

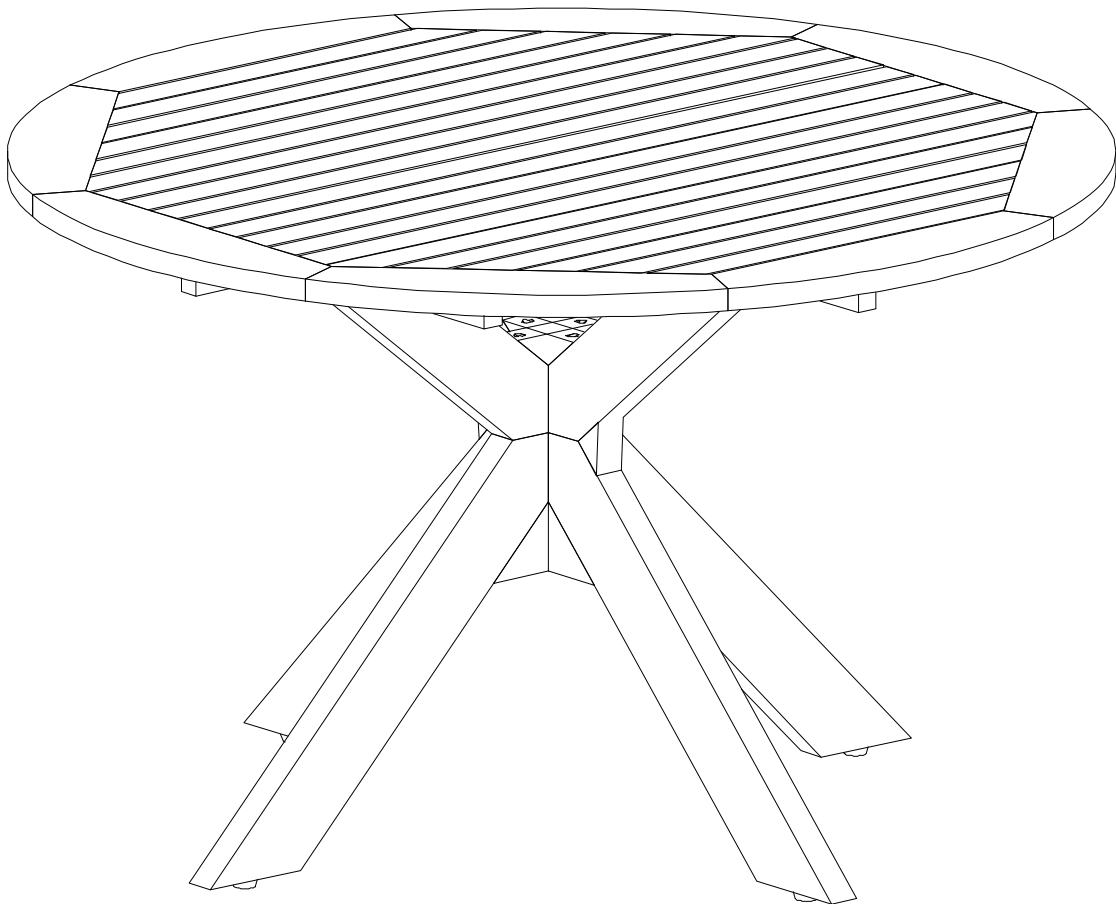

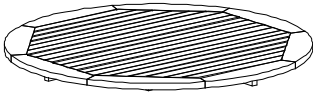
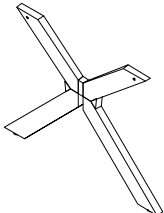
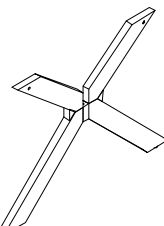
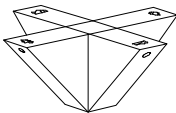
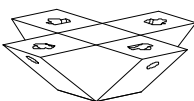

CAUTION : This Table is NOT a TOY.
Keep your child / children at bay during the assembly process.
For moving the Table and to prevent damage to the Table, two adults are needed to execute this action.

Parts List

Label	Picture	Description	QTY
A		Table Top	1
B		First Leg Frame (with Leveler)	1
C		Second Leg Frame (with Leveler)	1
D		Lower Cross Block	1
E		Upper Cross Block	1

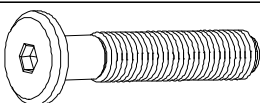
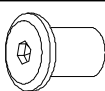
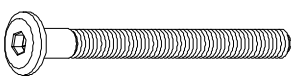
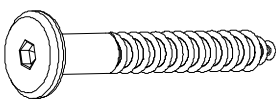
Hardware

Label	Picture	Description	QTY
①		Short Bolts (M8x55mm)	5
②		Sleeve Nut (M8x20mm)	5
③		Long Bolts (M6x90mm)	2
④		Screw (M7x45mm)	9
⑤		Allen key	2
⑥		Iron washer	5

Assembly Preparation

Before Beginning Assembly:

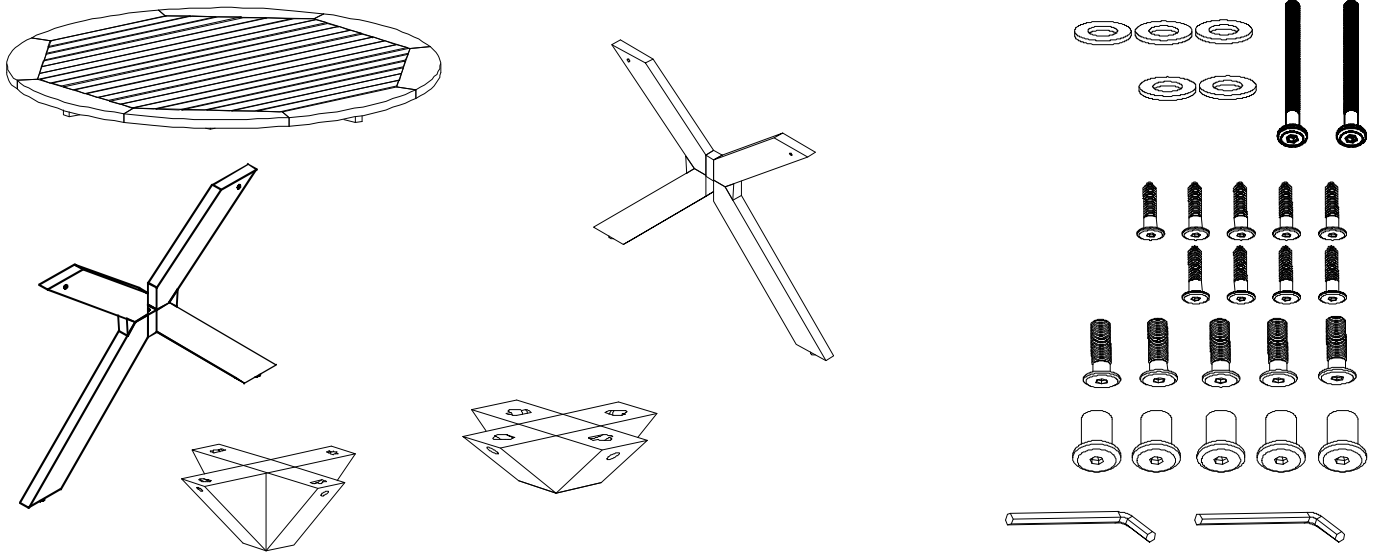

- Read instructions, cover to cover-



- Have 2 adults on hand for assembly-



- Do not assemble on flooring or carpet-



- Assemble on a clean non-marring surface (packing foam)-



- Save all packaging until finished-

Assembly Steps

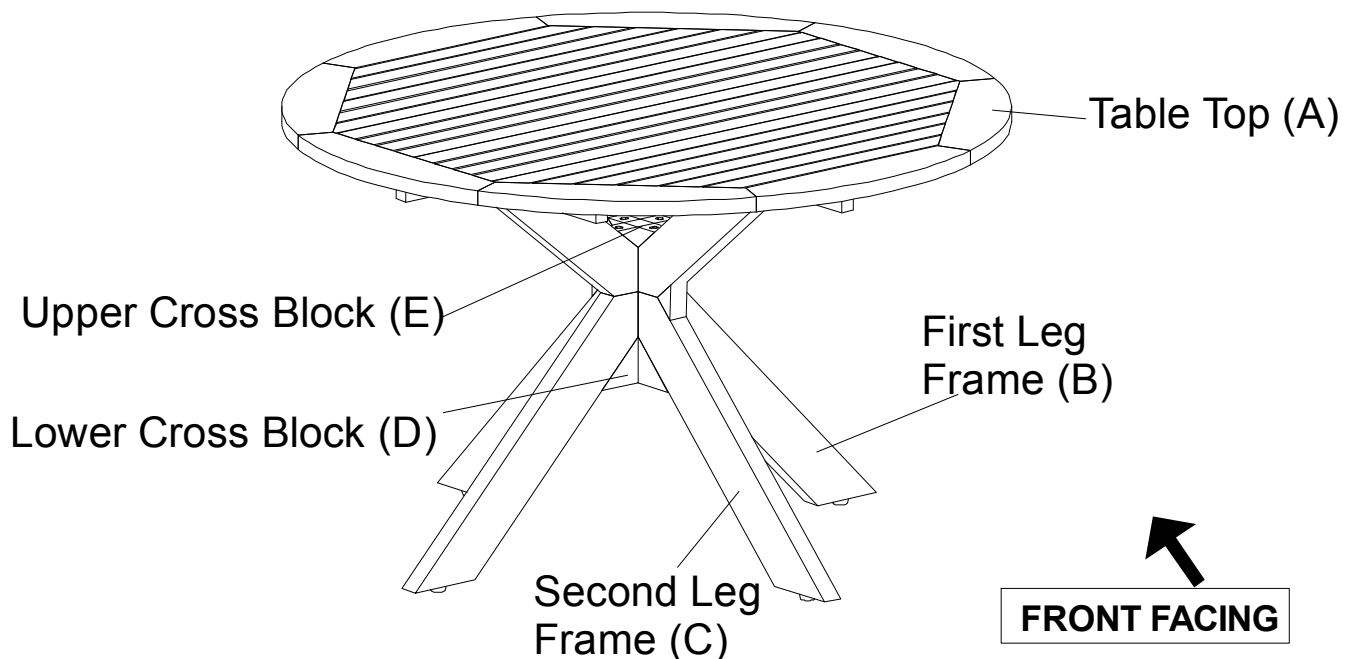

This Table has multiple parts and may require up to 30 minutes to assemble. To give you an overview of the Table parts, the above picture is to help you put the various parts into perspective. Please read through the instructions below to familiarise yourself with the parts and steps before assembly.

Step 1

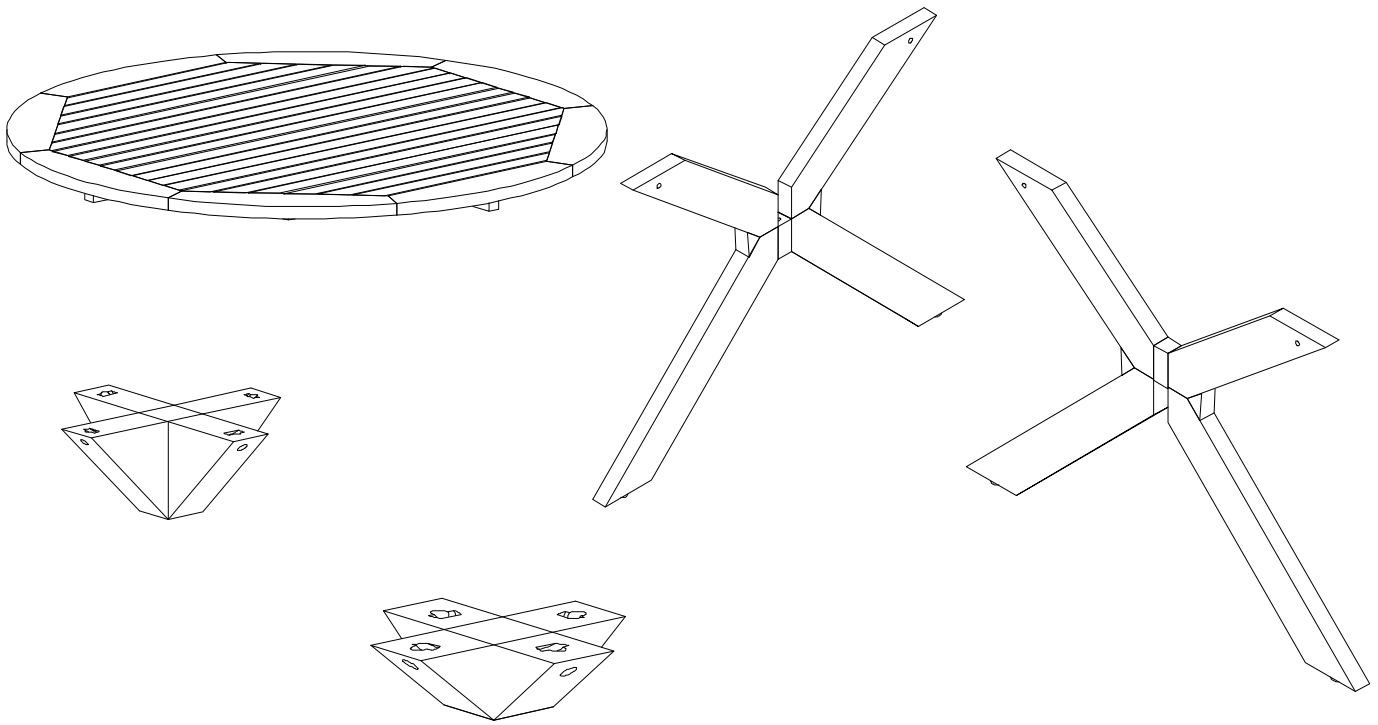

Unpack and place all parts on a clean, non-marring surface.

Step 2

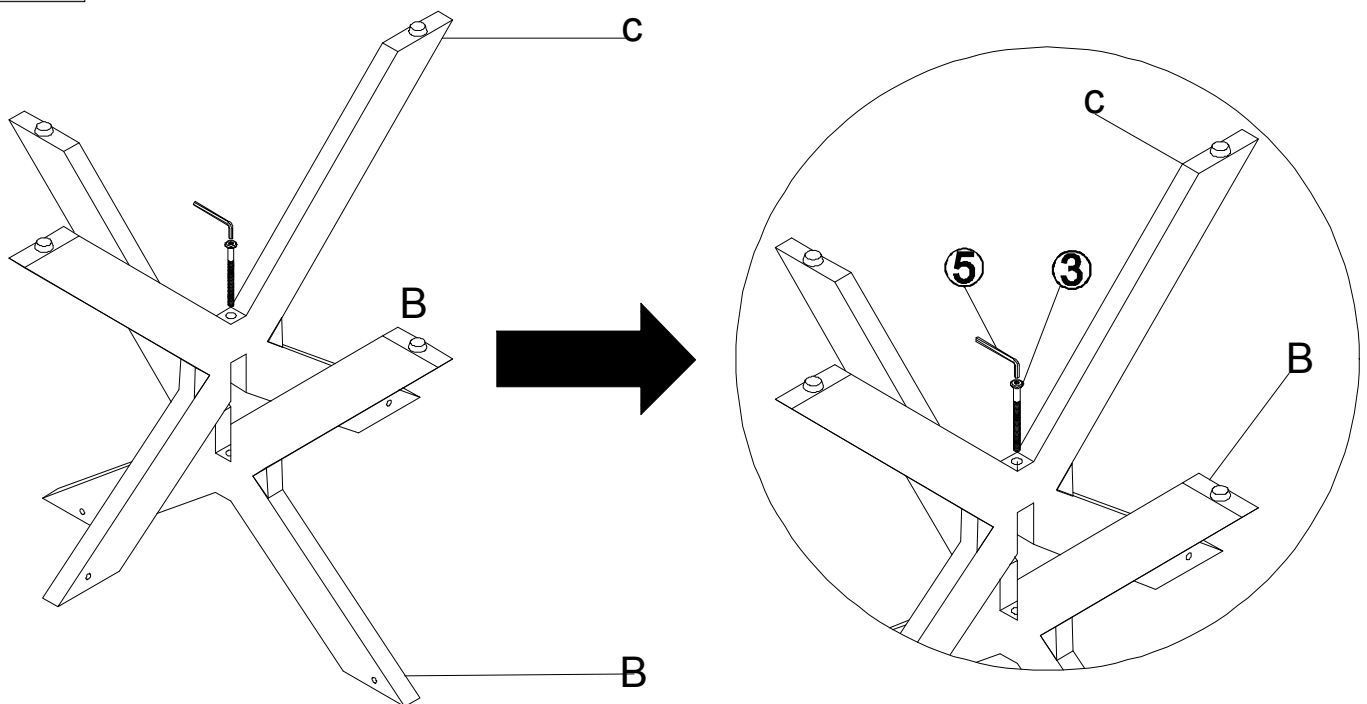

With the assistance of your partner, position the First Leg Frame(B) to the Second Leg Frame © as picture above.

Secure First Leg Frame(B) with the Second Leg Frame (C) by using Long Bolt (③) and Allen Key (⑤).

Note: This step, legs with leveler will be upside down.

Do not fully tighten the Bolts.

Step 3

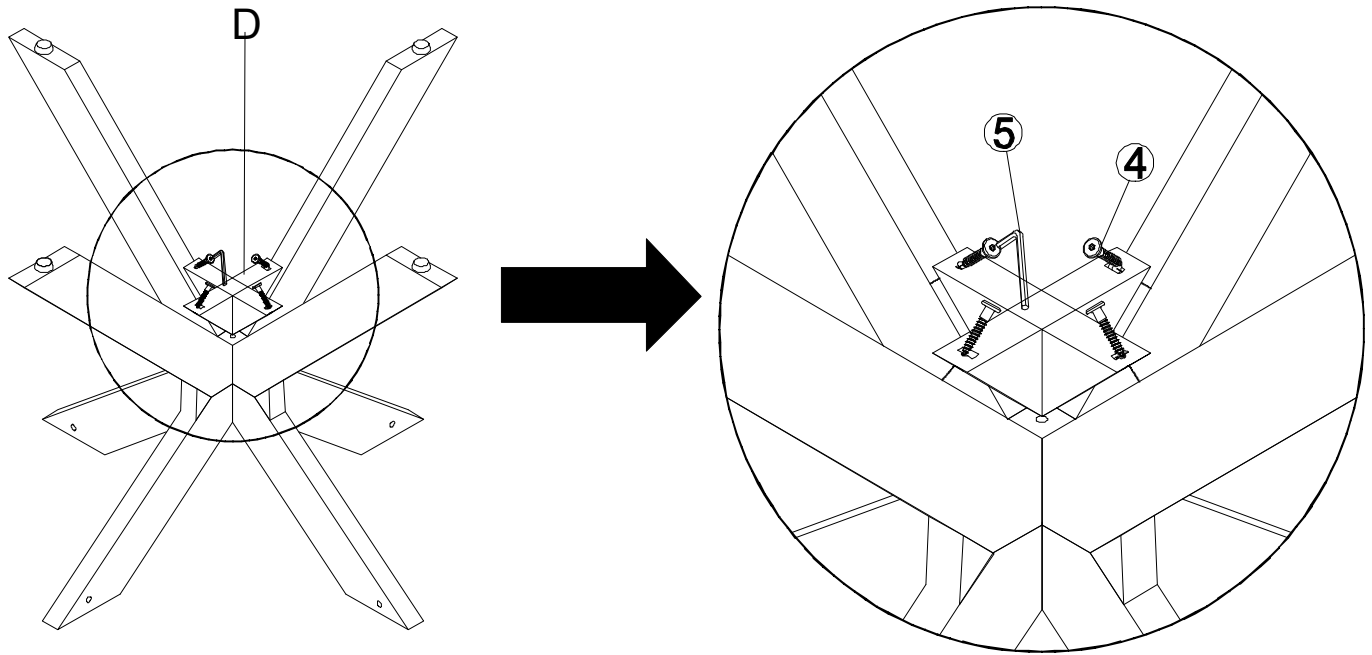

With the assistance of your partner, position the Lower Cross Block (D) onto the Leg Frames in Step 2. Secure by using Screws (④) and the Allen Key (⑤). **Do not fully tighten the Screws.**

Step 4

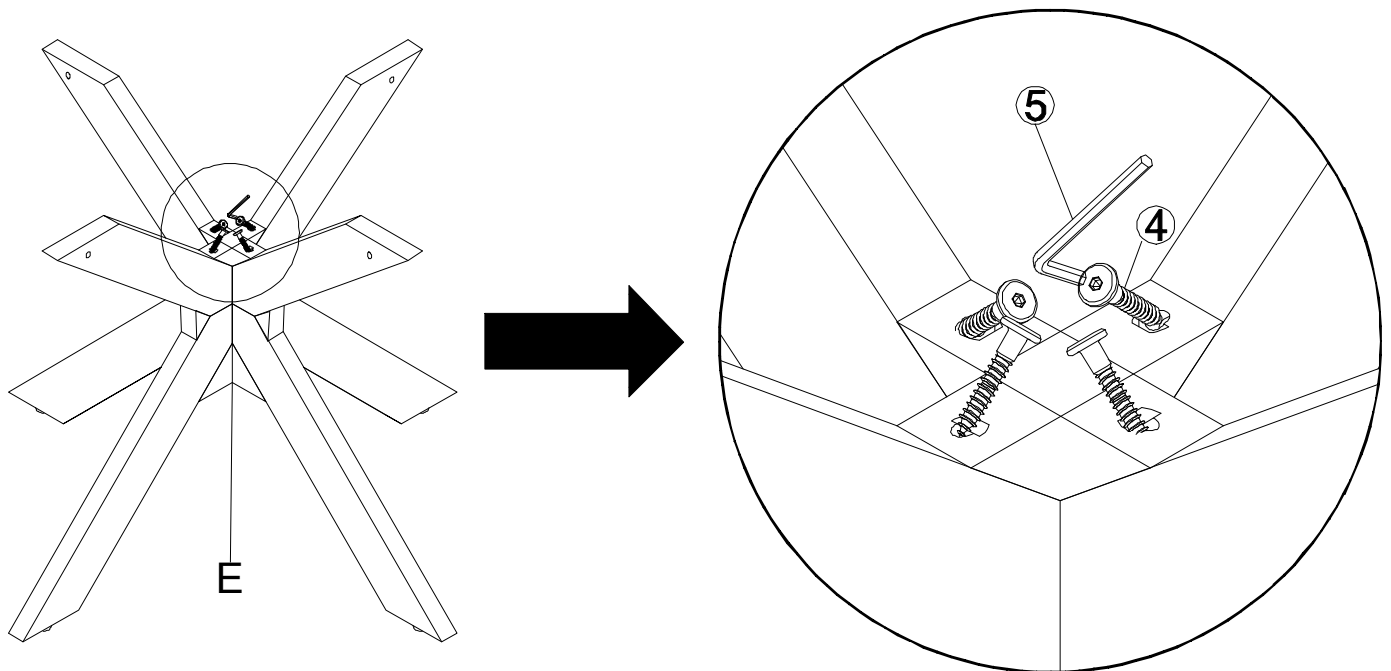

With the assistance of your partner, turn Leg Frame in step 3 180 degree. Position the Upper Cross Block (E) onto the Leg Frame as picture above. Secure by using Screws (④) and the Allen Key (⑤). **Do not fully tighten the Screws.**

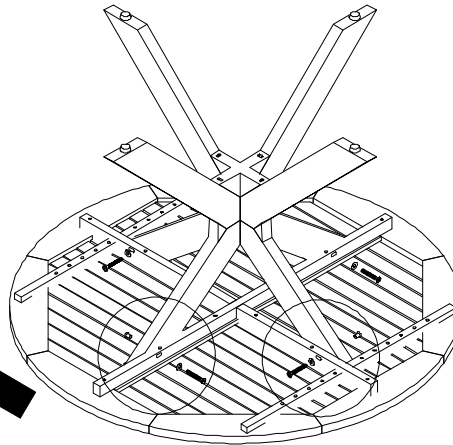
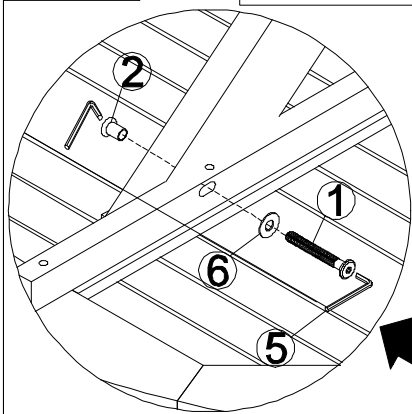
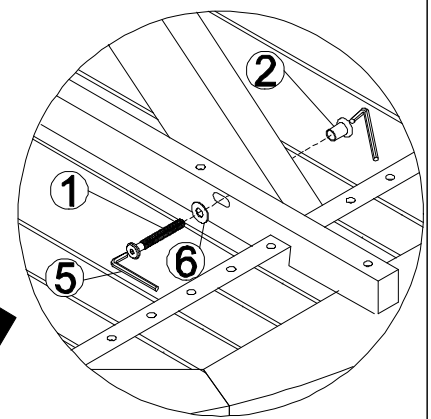
Step 5**STEP 5.1****STEP 5.2**

Place Table top (A) with its underside skywards onto a clean, soft surface to avoid any scratch or damage to the product.

Position Leg Frame in step 4 onto Table Top (A)

5.1) Using two Short Bolts (①), two Sleeve Nuts (②), two Iron Washer (⑥) and Allen Key (⑤) to connect middle support bar of Table Top (A) and Leg Frame (B & C).

5.2) Using two Short Bolts(①), two Sleeve Nuts (②), two Iron Washer (⑥) and Allen Key (⑤) to connect side support bar of Table Top (A) and Leg Frame (B & C).

Do not fully tighten the Bolts.

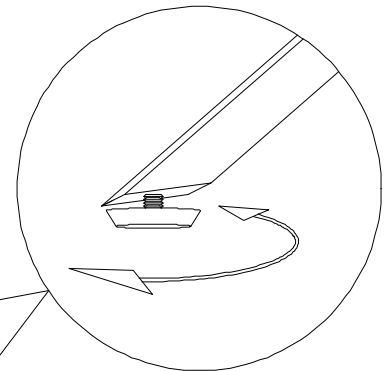
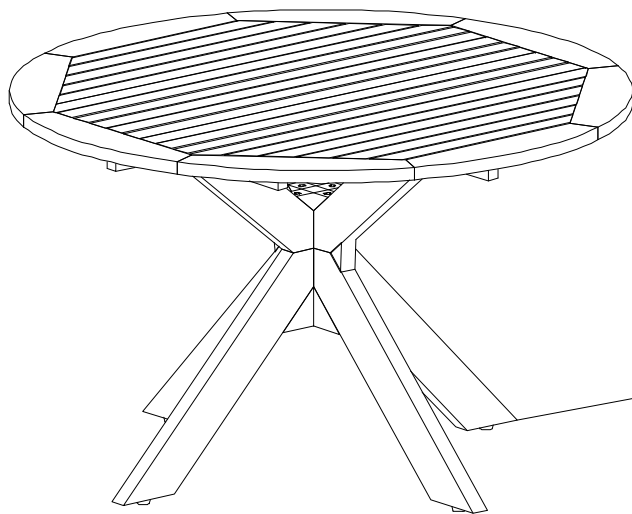
Step 6

LEVELER

With assistance from your adult partners, turn the Table back to normal flat ground

EXERT pressure, floorwards, onto the Table.

This pressure will help the Legs and Table Top reach alignment at all joints. Check for wobbles.

In a sequential manner, gradually tighten all Screws and Bolts until evenly secured.

Inspect the Table and make sure all parts are adequately connected.

Your Table is ready for use.

This Table can only be used on a flat, level surface.

Care & Maintenance

-  Do not put hot items directly on furniture surface
 -  Do not clean furniture with harsh cleansers or polish.
 -  To obtain the longest lifespan of your outdoor products, minimizing exposure to direct sunlight is recommended.
 -  Children should not climb or jump on the furniture.
 -  Do not write on furniture without a padded barrier to protect the surface.
 -  To obtain the longest lifespan of your outdoor products, avoid extended and lengthy exposure to rain, snow, and direct sunshine. Whenever possible cover the product and /or place under patio or awnings.
 -  Not for commercial use. For residential use only .
 -  Stains may be removed with mild soap solution and damp cloth.
-

-  Dust and pick-up spills using a clean, non-colored, lint-free cloth .