

### STEP 3

Attach Panel (A) and Long Pole (1) to the assembled unit, as shown.

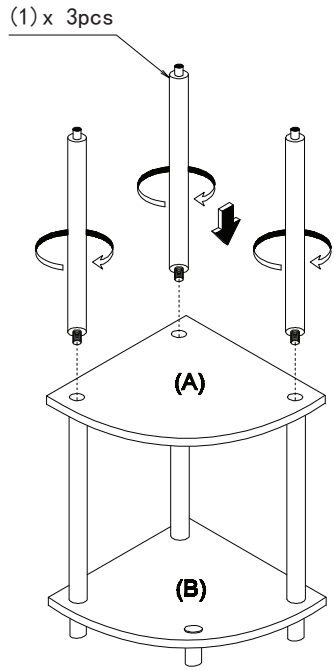

### STEP 4

Attach another piece of Top Panel (A) and tighten it using Top Cap (2).

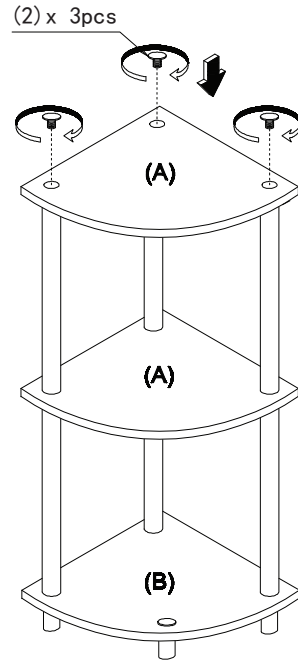

# Assembly Instruction

00:10

Approx. 10 minutes



Recomm. 1 Person



No Tools Required

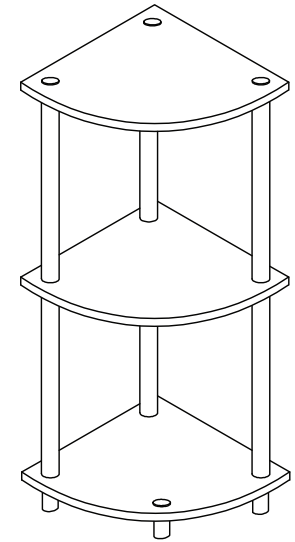

### Recommended Maximum Weight

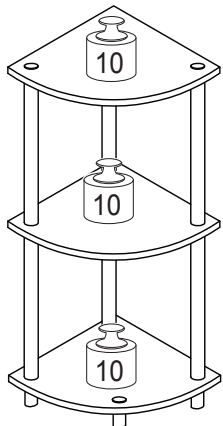



\*Unit in Pound(lbs)



### **WARNING:**

>This unit has been designed to support the maximum loads shown. Exceeding these load limits could cause sagging, instability, product collapse, and/or serious injury.

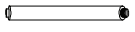
>DO NOT allow children to climb on unit.

>Put heavier items on lower shelves.

No	Hardware List	Qty
1	Long Pole 	6pcs
2	Top Cap 	4pcs
3	Round Leg 	4pcs

No	Parts List	Qty
A	Top Panel 	2pcs
B	Bottom Panel 	1pc

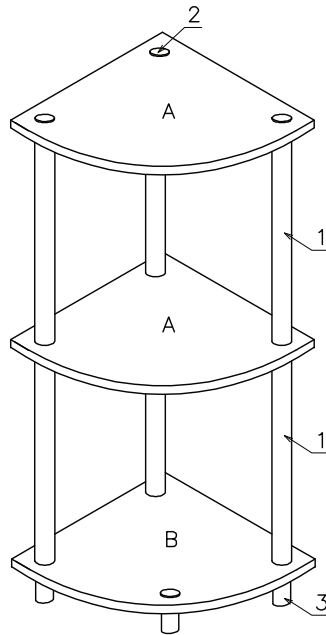

#### **USEFUL HINTS BEFORE YOU START:**

1. Read each step carefully before starting.
2. It is important that each step is performed in correct order to avoid difficulties.
3. Identify, sort and count the parts before assembly.
4. Assemble your furniture on packaging cardboard to prevent scratch or damage.
5. Clean the product with mild cleanser using soft damped cloth. Do not use harsh or abrasive cleanser.
6. Using incompatible hardware might cause damage to product.

#### **STEP 1**

- 1.1 Fix Round Leg (3) to the bottom of Bottom Panel (B), as shown.
- 1.2 Tighten with 1 piece of Top Cap (2) on the center hole, as shown.

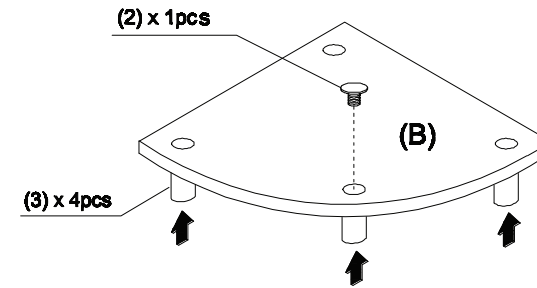

#### **STEP 2**

Attach Long Pole (1) on Bottom Panel (B) and tighten it.

