

# ASSEMBLY INSTRUCTION

## DINING BENCH

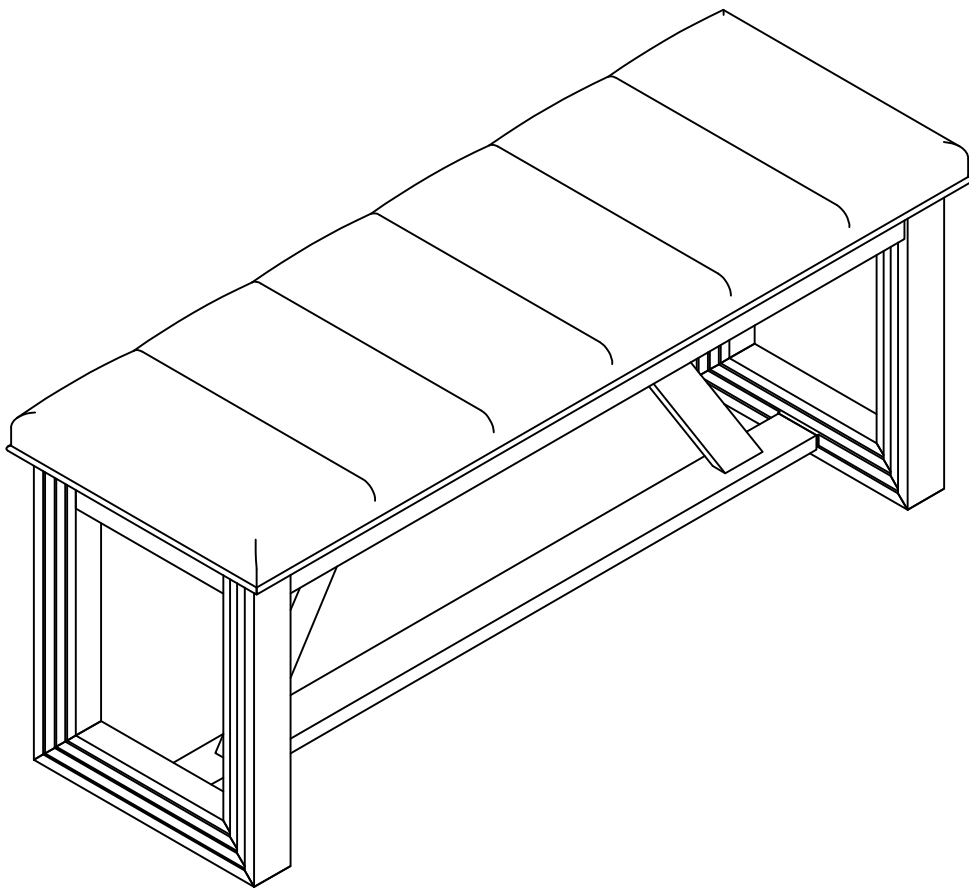







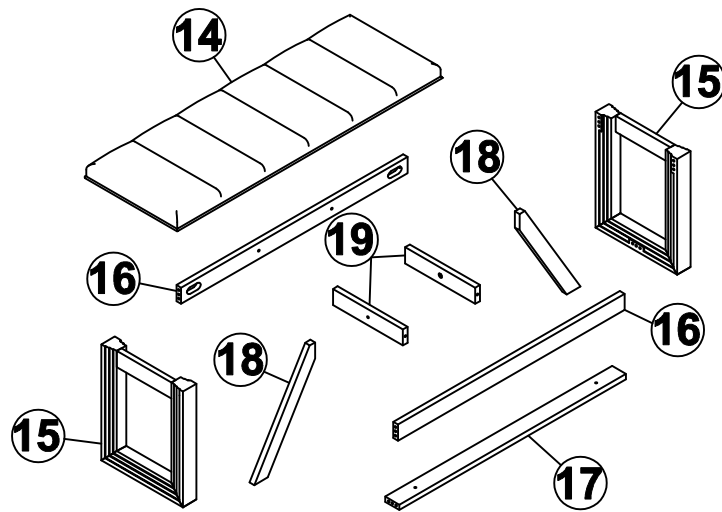

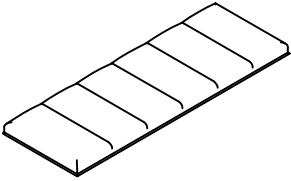

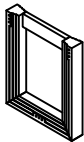

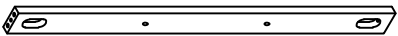
WF324182

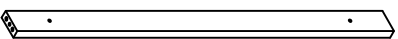
**IMPORTANT NOTE :**

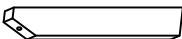
- ① PLACE ALL PARTS ON A CLEAN AND SMOOTH SURFACE SUCH AS A RUG OR CARPET TO AVOID THE PARTS FROM BEING SCRATCHED.
- ② BEFORE YOU BEGIN , KINDLY FOLLOW THE ASSEMBLY INSTRUCTIONS STEP BY STEP.
- ③ DO NOT TIGHTEN ALL SCREWS AND BOLTS UNTIL THE BENCH IS FULLY SET-UP

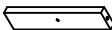

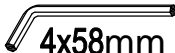

PART LIST FOR ONE BENCH		HARDWARE LIST FOR ONE BENCH	
<b>14</b>	 SEAT BENCH (1pc)	<b>L</b>	 Ø1/4" x 55mm BOLT (6pcs)
<b>15</b>	 FRAME LEGS BENCH (2pcs)	<b>Q</b>	 Ø1/4" x 40mm BOLT (4pcs)
<b>16</b>	 TOP LONG STRETCHER (2pcs)	<b>R</b>	 Ø8 x 30mm WOODEN PEGS (16pcs)
<b>17</b>	 LONG STRETCHER (1pc)	<b>S</b>	 Ø15 x 15 x 2mm METAL ANGLE (12pcs)
<b>18</b>	 STRETCHER (2pcs)	<b>T</b>	 Ø40 x 40 x 20mm METAL ANGLE (4pcs)
<b>19</b>	 STRETCHER (2pcs)	<b>U</b>	 Ø19"x15x10mm PLASTIC WASHER (6pcs)
		<b>V</b>	 Ø4 x 15mm SCREW (40pcs)
		<b>H</b>	 4x58mm ALLENKEY (1pc)

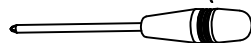
ASSEMBLY TOOLS REQUIRED ( NOT INCLUDED )



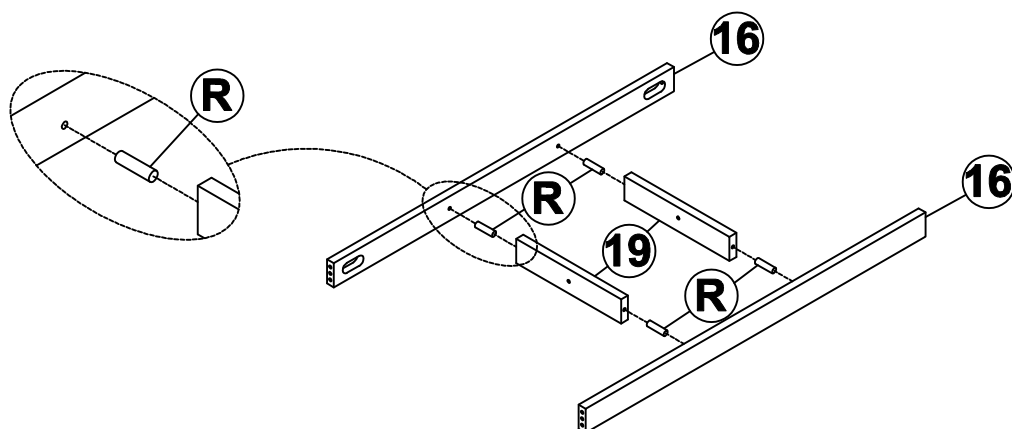



# Step 1

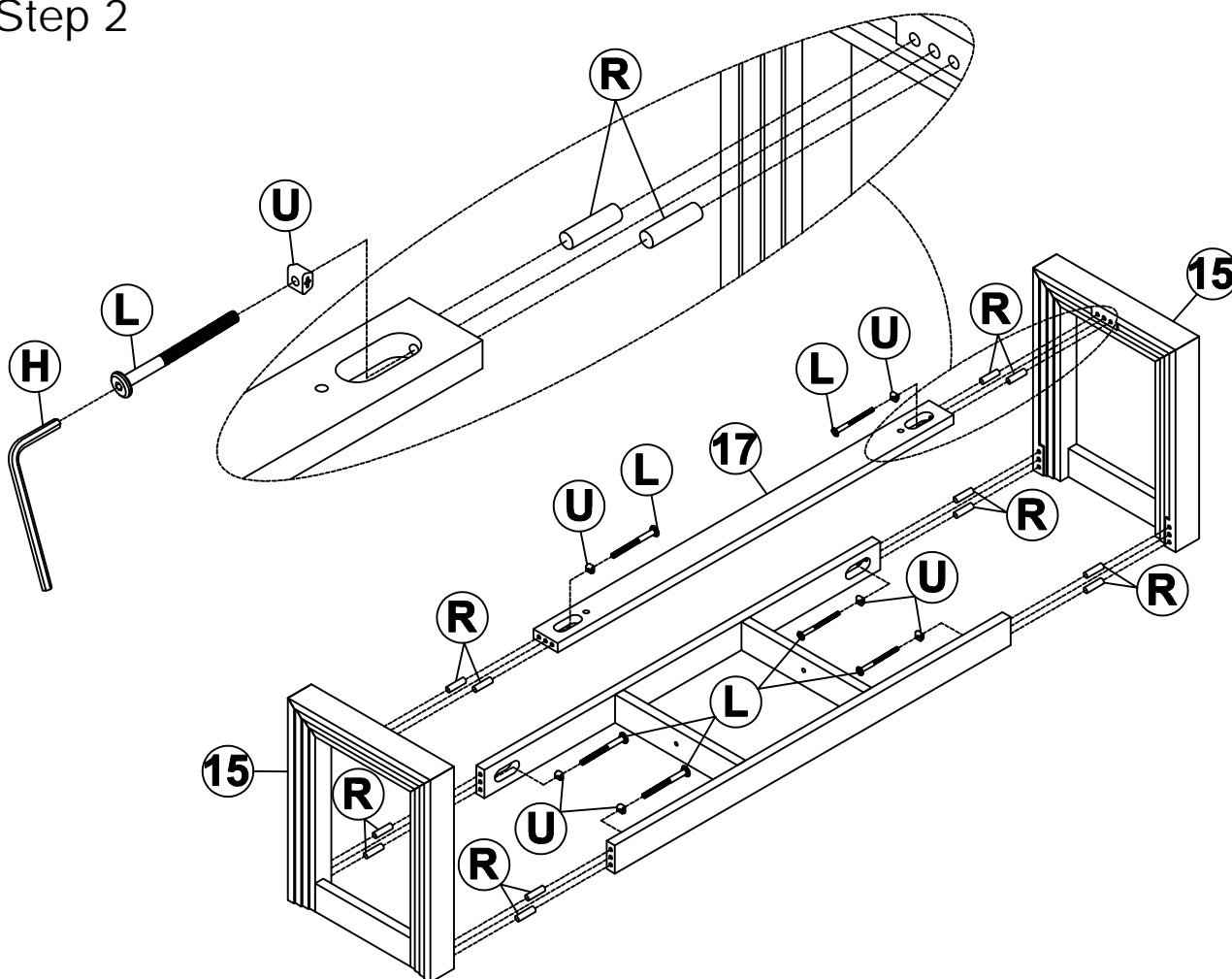

<b>R</b>	∅8x30		4PCS
----------	-------	---	------



# Step 2



<b>L</b>	∅1/4"x55		6PCS	<b>U</b>	19x15x10		6PCS
<b>R</b>	∅8x30		12PCS	<b>H</b>	4x58		1PC

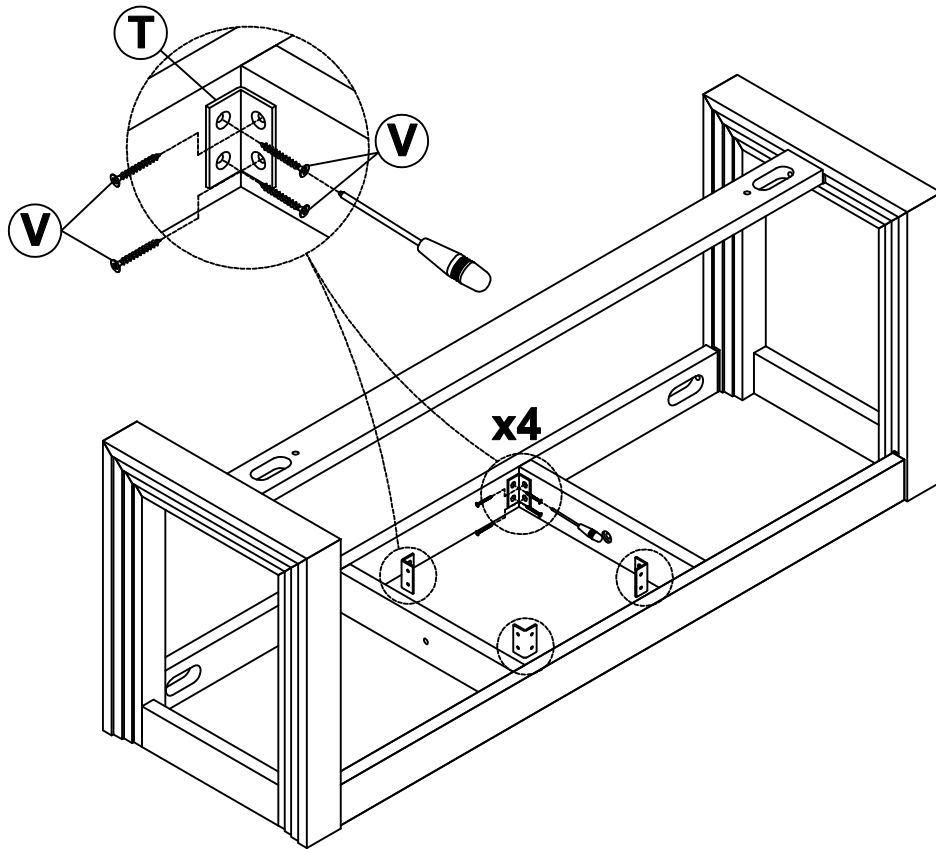

### Step 3

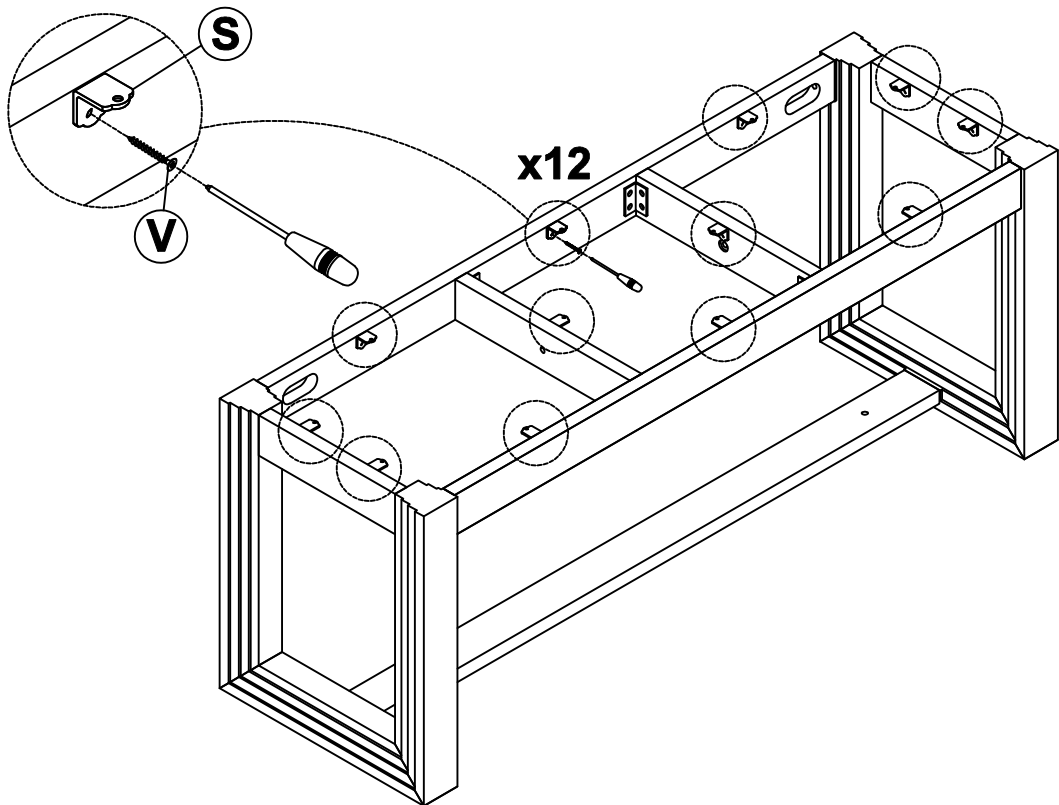

<b>T</b>	40x20x20		4PCS	<b>V</b>	Ø4x15		16PCS
----------	----------	---	------	----------	-------	---	-------

### Step 4



<b>S</b>	15x15x2		12PCS	<b>V</b>	Ø4x15		12PCS
----------	---------	---	-------	----------	-------	---	-------

# Step 5

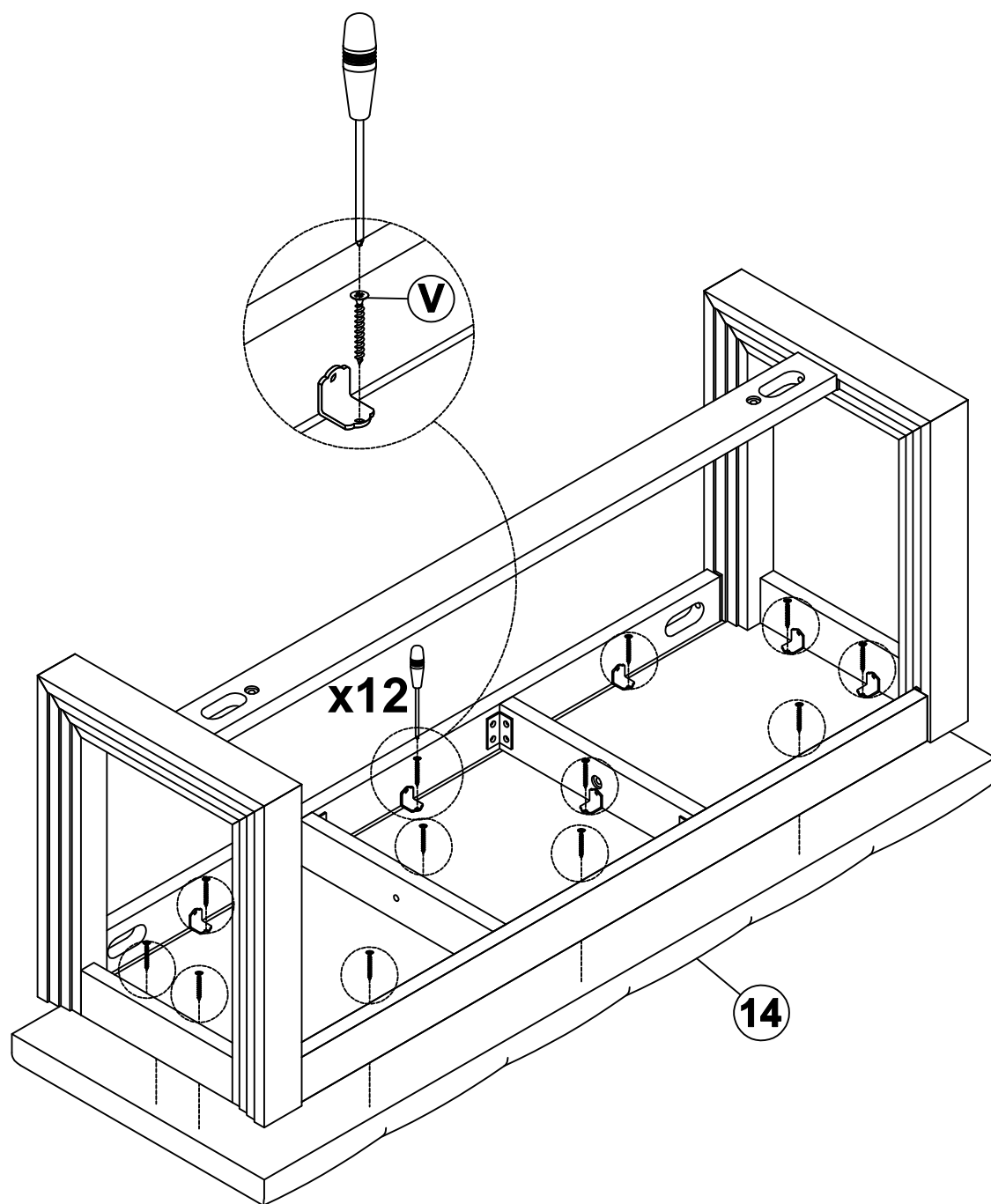

<b>V</b>	Ø4x15		12PCS
----------	-------	---	-------

# Step 6

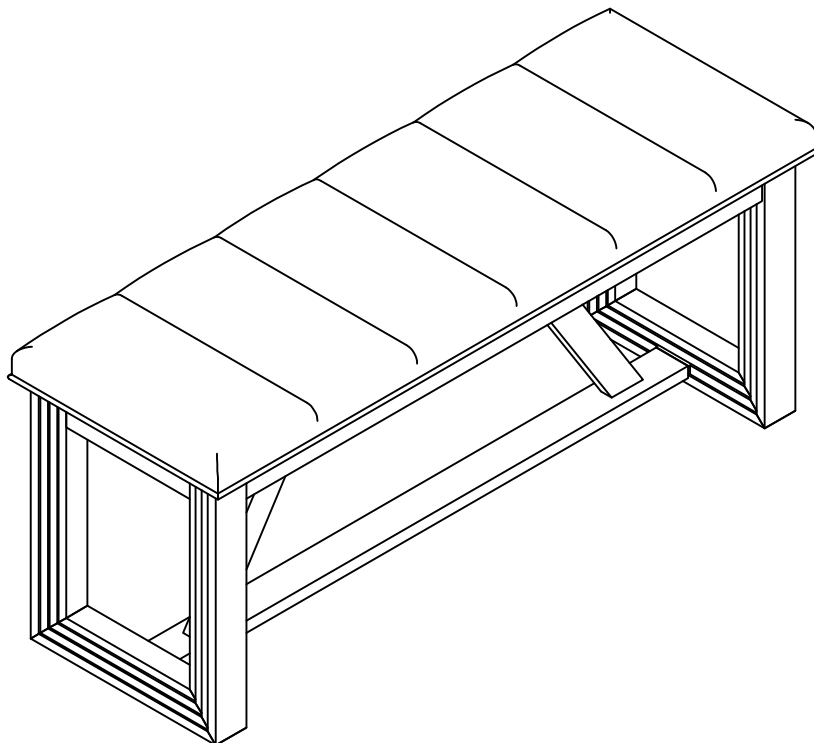
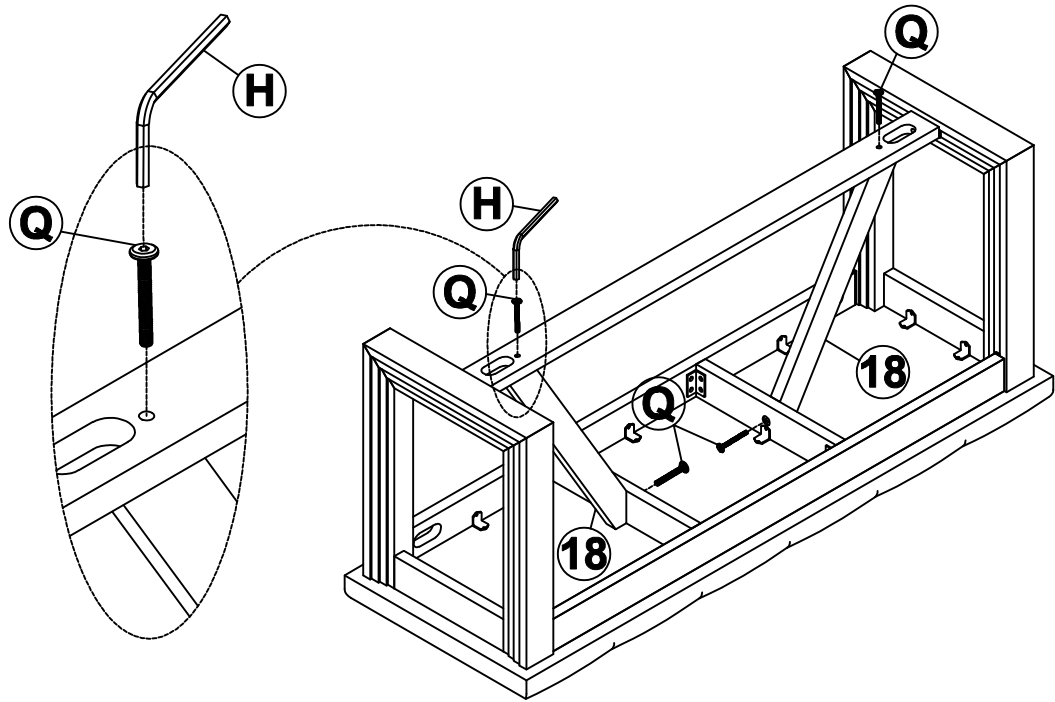

Complete

Q	Ø1/4"x40 	4PCS	H	4x58 	1PC
---	--	------	---	--	-----