

ASSEMBLY INSTRUCTIONS

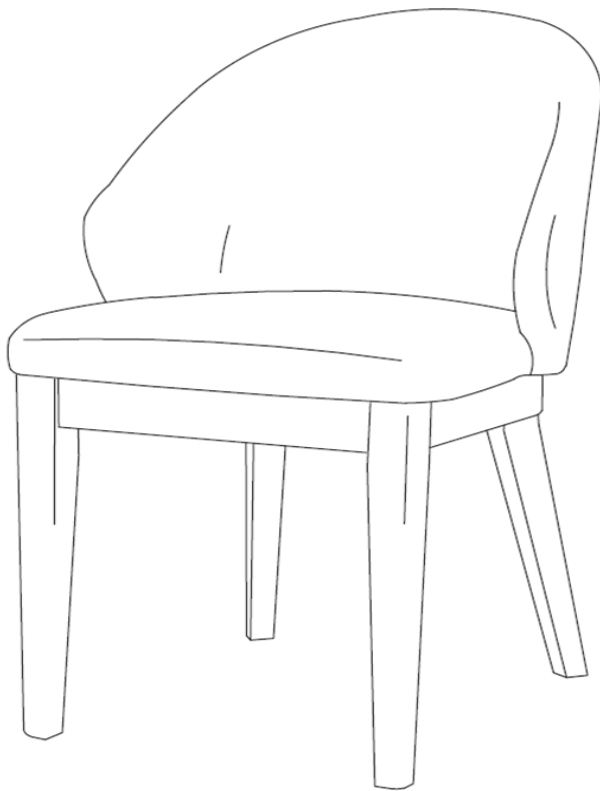

TOOLS REQUIRED



Screwdriver
(Not included)

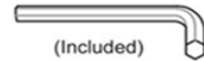

(Included)
Allen Wrench



2 - People

ASSEMBLY RATING



EASY —————> DIFFICULT

The Assembly Rating is a 5-point system showing the level of effort needed to assemble a specific product.

VERSION # 25-12-05



CHECK BEFORE STARTING

Are you missing anything?
Double-check all parts, hardware and accessories listed are all accounted for.

Should we send any replacements?
Are there any irregularities or flaws in the parts? We can send replacements!

Check out our Quick Tips!
We recommend reviewing the pre-assembly handouts. Even experts need a refresher now and then!

Prep Time!
Please review the assembly instructions and all diagrams prior to assembling.

PRE ASSEMBLY INTRODUCTION

We understand building ready-to-assemble furniture can be a challenging experience for some. To help avoid confusion, we have provided some helpful tips that may speed up the process.



Teamwork

ALWAYS have at least two people to help with transporting and assembling the product to avoid potential injury and/or damage.



Suitable Location

Assembling near the area of the intended location is highly recommended.



Sufficient Space

Make sure you have enough space to move around during the assembly.



Avoid Scratches

Use cardboard, blankets or a carpeted area while assembling furniture to prevent to prevent scratches and damages.



Flat Surface

Make sure the furniture rests on a flat and level surface with each leg evenly touching the floor.

ASSEMBLY AND CARE ADVICE



FAILURE TO FOLLOW THE GUIDELINES BELOW MAY RESULT IN INJURY AND/OR PROPERTY DAMAGE.



Position each part correctly and insert screws or bolts into their respective holes.

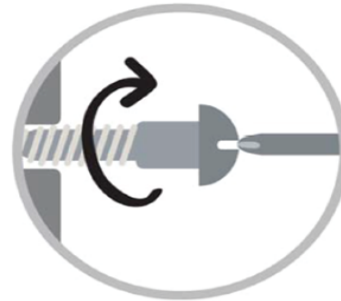

Turn clockwise to tighten and only tighten when step is completed or when instructed to do so.



Use the appropriate hand tools or power tools for assembly. Select steps, such as tightening screws and/or bolts, may require hand tools to avoid causing damage during assembly.



Save the instructions and store any supplied tools for later maintenance.



After two weeks, check and tighten any loose hardware and repeat again every six months thereafter.

IT IS THE USER'S RESPONSIBILITY TO MAINTAIN THE FURNITURE. THE HARDWARE MAY LOOSEN OVER TIME AND MAY CAUSE THE FURNITURE TO BE WOBBLY AND UNABLE TO SUPPORT ITS INTENDED WEIGHT CAPACITY. THIS MAY LEAD TO COLLAPSE AND MAY CAUSE SERIOUS INJURY.

ARM CHAIR



- Please keep instructions for future reference.
- Check the quantity and irregularity of parts and hardware before you start.

PARTS

(P1) - 2 PCS

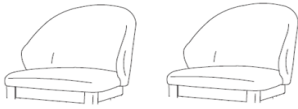

CHAIR SEAT FRAME

(P2) - 4 PCS



FRONT LEG

(P3) - 4 PCS



BACK LEG

HARDWARE

(H1) - 16 PCS



M6x60mm JCBC SCREW

(H2) - 16 PCS



SPRING WASHER

(H3) - 16 PCS



FLAT WASHER

(H4) - 1 PC



ALLEN KEY

(H5) - 8 PCS



NAIL LEG

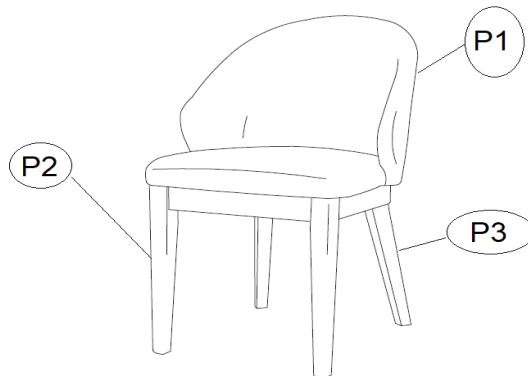

packed in 1 carton







Please read instructions carefully

Remove all wrapping materials, staples and packing straps from the carton. Refer to Parts List and Hardware List and ensure they are complete before you start assembling. Place all wooden parts on a clean, flat and soft surface (e.g carpet or rug) to prevent parts from being scratched.

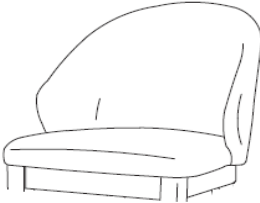
CAUTIONS: 1) DO NOT FULLY TIGHTEN BOLTS AND NUTS UNTIL ALL PARTS HAVE BEEN ASSEMBLED.

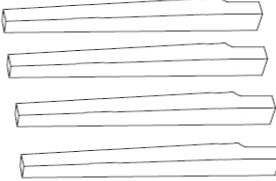
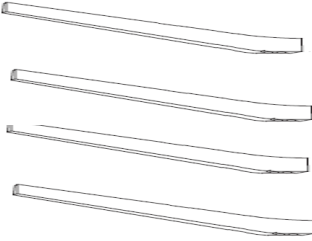
2) DO NOT OVER-TIGHTEN BOLTS AND NUTS .

3) KEEP ALL HARDWARE PARTS OUT OF REACH OF CHILDREN.

Carton	Designation	Part List	Hardware List
	CHAIR SEAT FRAME P1	 P1 x 2pc	 H1 x 16pc
	FRONT LEG P2	 P2 x 2pc	M6x60mm JCBC SCREW
	BACK LEG P3	 P3 x 4pc	 H2 x 16pc
			Spring Washer
			 H3 x 16pc
			Flat Washer
			 H4 x 1pc
			Allen Key
			 H5 x 8pc
			Nail Leg

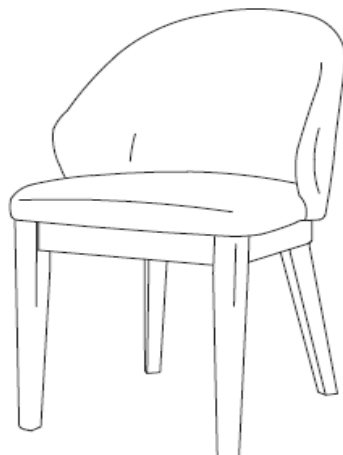

COMPLETE ASSEMBLY





ASSEMBLY INSTRUCTIONS

SIDE CHAIR

PARTS LIST (FOR 2 CHAIRS)

NO.	COMPONENT	QTY.
P1	CHAIR SEAT FRAME	2
P2	FRONT LEG	4
P3	BACK LEG	4

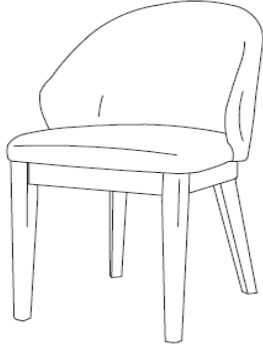

HARDWARE LIST (FOR 2 CHAIRS)

NO.	DESCRIPTION	QTY.
H1	JCBC SCREW M6 x 60MM 	16
H2	SPRING WASHER 	16
H3	FLAT WASHER 	16
H4	ALLEN KEY 	1
H5	NAIL LEG 	8

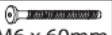

COMPLETE ASSEMBLY

STEP 1

H1 x 8	 M6 x 60mm
H2 x 8	
H3 x 8	

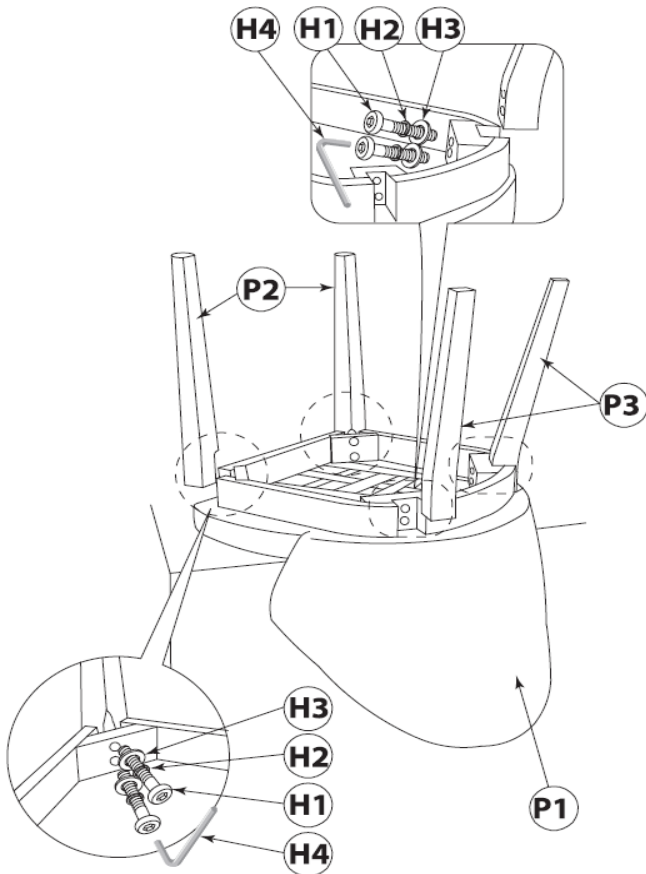

STEP 2

H5 x 4	
--------	---

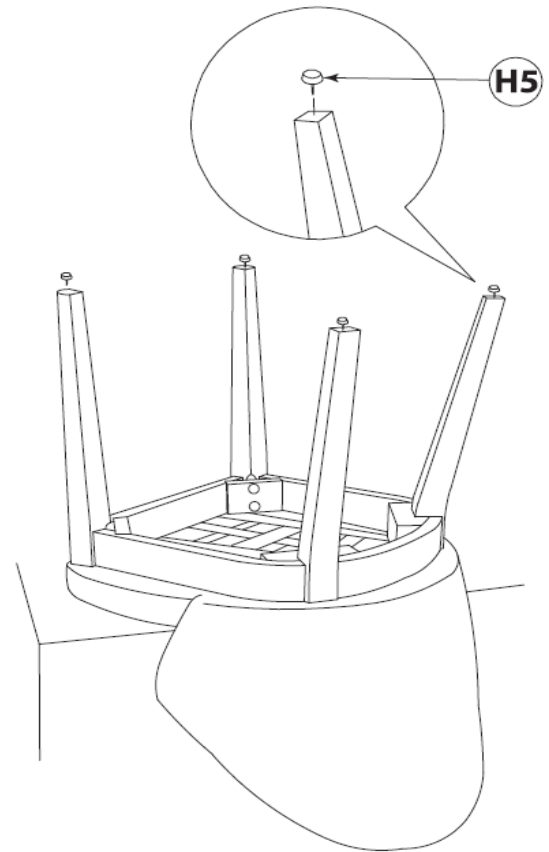

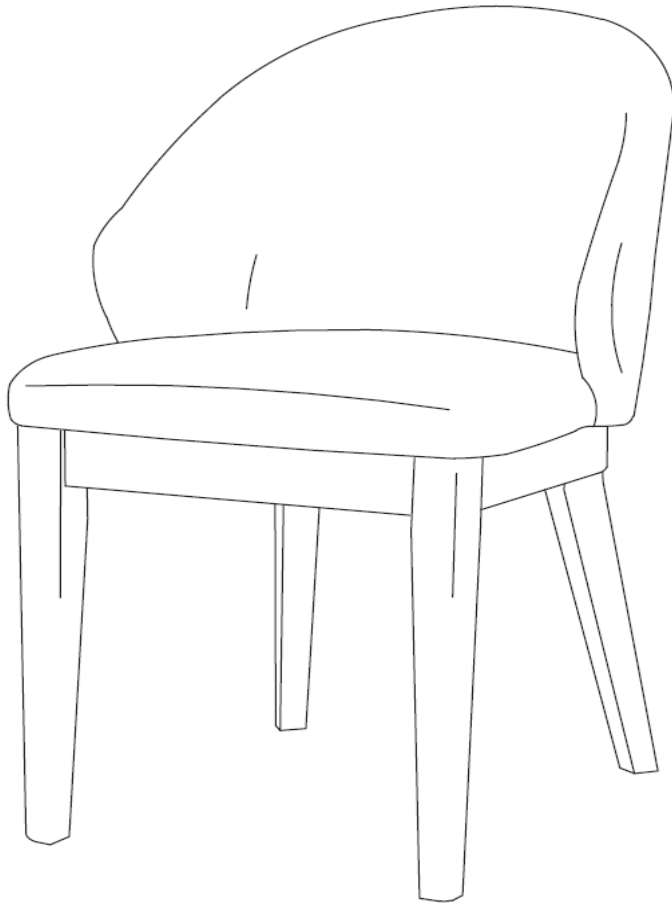

ASSEMBLY COMPLETED



Please ensure the furniture rests on an even and flat surface. If the product wobbles or feels loose, double-check all bolts and/or screws are properly tightened and secured.



Keep this handy!

Please retain this instruction manual and any order-related information for future reference.



Lift, don't drag!

To avoid damage to product please always LIFT the product when transporting or adjusting the placement.

This product is intended for RESIDENTIAL USE ONLY and not for commercial use .

CARE AND MAINTENANCE

SAFETY - To avoid any risk of suffocation to children or animals, dispose off the plastic bags immediately.

CLEANING - Clean with damp cloth and mild detergent. Do not use bleach or abrasive products.

FITTINGS - Tighten bolts and nuts from time to time to ensure all parts of product are securely fitted.

ASSEMBLY INSTRUCTIONS

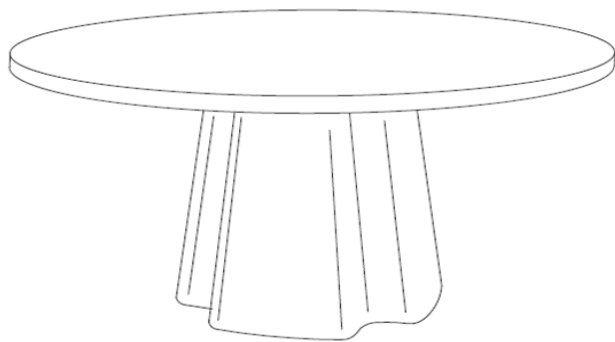

TOOLS REQUIRED



Screwdriver
(Not included)

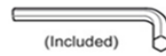

(Included)
Allen Wrench



2 - People

ASSEMBLY RATING



EASY —————> DIFFICULT

The Assembly Rating is a 5-point system showing the level of effort needed to assemble a specific product.

VERSION # 25-12-05



CHECK BEFORE STARTING

Are you missing anything?

Double-check all parts, hardware and accessories listed are all accounted for.

Check out our Quick Tips!

We recommend reviewing the pre-assembly handouts. Even experts need a refresher now and then!

Should we send any replacements?

Are there any irregularities or flaws in the parts? We can send replacements!

Prep Time!

Please review the assembly instructions and all diagrams prior to assembling.

PRE ASSEMBLY INTRODUCTION

We understand building ready-to-assemble furniture can be a challenging experience for some. To help avoid confusion, we have provided some helpful tips that may speed up the process.



Teamwork

ALWAYS have at least two people to help with transporting and assembling the product to avoid potential injury and/or damage.



Suitable Location

Assembling near the area of the intended location is highly recommended.



Sufficient Space

Make sure you have enough space to move around during the assembly.



Avoid Scratches

Use cardboard, blankets or a carpeted area while assembling furniture to prevent scratches and damages.



Flat Surface

Make sure the furniture rests on a flat and level surface with each leg evenly touching the floor.

ASSEMBLY AND CARE ADVICE



FAILURE TO FOLLOW THE GUIDELINES BELOW MAY RESULT IN INJURY AND/OR PROPERTY DAMAGE.



Position each part correctly and insert screws or bolts into their respective holes.



Turn clockwise to tighten and only tighten when step is completed or when instructed to do so.



Use the appropriate hand tools or power tools for assembly. Select steps, such as tightening screws and/or bolts, may require hand tools to avoid causing damage during assembly.



Save the instructions and store any supplied tools for later maintenance.



After two weeks, check and tighten any loose hardware and repeat again every six months thereafter.

IT IS THE USER'S RESPONSIBILITY TO MAINTAIN THE FURNITURE. THE HARDWARE MAY LOOSEN OVER TIME AND MAY CAUSE THE FURNITURE TO BE WOBBLY AND UNABLE TO SUPPORT ITS INTENDED WEIGHT CAPACITY. THIS MAY LEAD TO COLLAPSE AND MAY CAUSE SERIOUS INJURY.

ROUND DINING TABLE



- Please keep instructions for future reference.
- Check the quantity and irregularity of parts and hardware before you start.

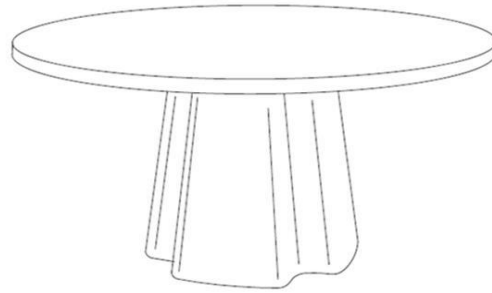

PARTS

P1 - 1PC

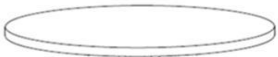

TABLE TOP

P2 - 1PC



PEDESTAL LEG

P3 - 1PC



MOUNTING PANEL

HARDWARE

H1 - 8 PCS



M6 X 35MM JCBC SCREW

H2 - 8 PCS



SPRING WASHER

H3 - 4 PCS



FLAT WASHER

H4 - 1 PC



ALLEN KEY

H5 - 8 PCS



LEG ADJUSTABLE GLIDE

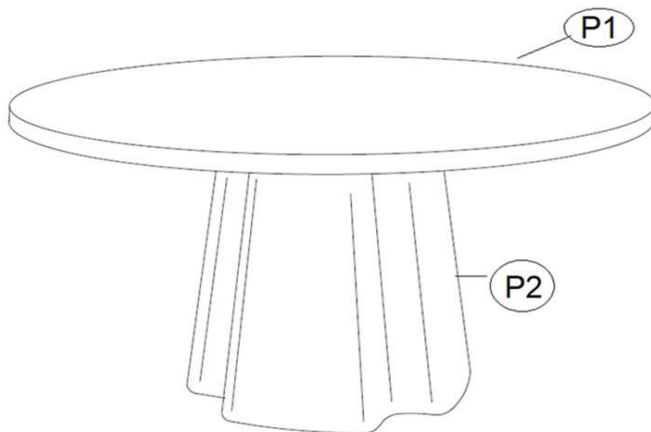

ASSEMBLY INSTRUCTIONS

Packed in 2 carton









Please read instructions carefully

Remove all wrapping materials, staples and packing straps from the carton. Refer to Parts List and Hardware List and ensure they are complete before you start assembling. Place all wooden parts on a clean, flat and soft surface (e.g carpet or rug) to prevent parts from being scratched.

CAUTIONS: 1) DO NOT FULLY TIGHTEN BOLTS AND NUTS UNTIL ALL PARTS HAVE BEEN ASSEMBLED.

2) DO NOT OVER-TIGHTEN BOLTS AND NUTS .

3) KEEP ALL HARDWARE PARTS OUT OF REACH OF CHILDREN.

Carton	Designation	Part List	Hardware List
	TABLE TOP	 P1 x 1pc	
	MOUNTING PANEL	 P3 x 1pc	
	PEDESTAL LEG	 P3 x 1pc	 H1 x 8pc M6x35 JCBC SCREW  H2 x 8pc Spring Washer  H3 x 4pc Flat Washer  H4 x 1pc Allen Key  H5 x 8pc Leg Adjustable Glide

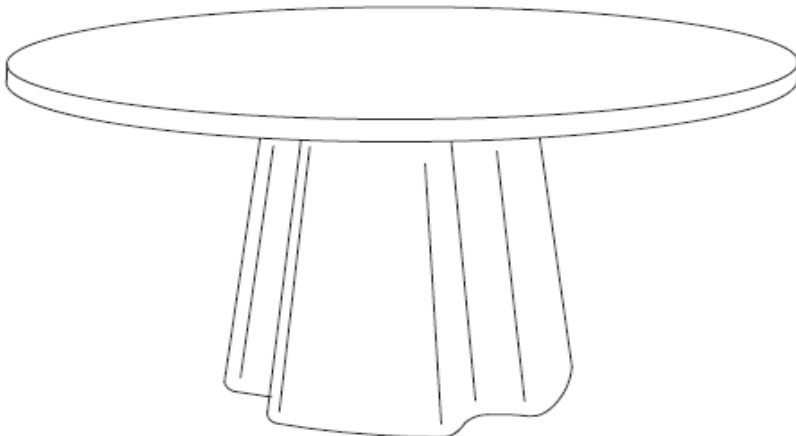





COMPLETE ASSEMBLY

ASSEMBLY INSTRUCTIONS

ROUND DINING TABLE

PART LIST		
No	Description	Qty
P1	TABEL TOP	1
P2	PEDESTAL LEG	1
P3	MOUNTING PANEL	1

HARDWARE LIST			
No	Description		Qty
H1	M6 x 35mm JCBC BOLT		8
H2	SPRING WASHER		8
H3	FLAT WASHER		4
H4	ALLEN KEY		1
H5	ADJUSTABLE LEG STUD		8

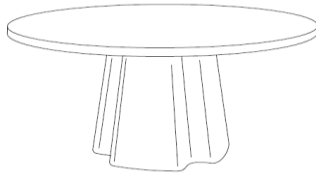

COMPLETE ASSEMBLY

STEP 1

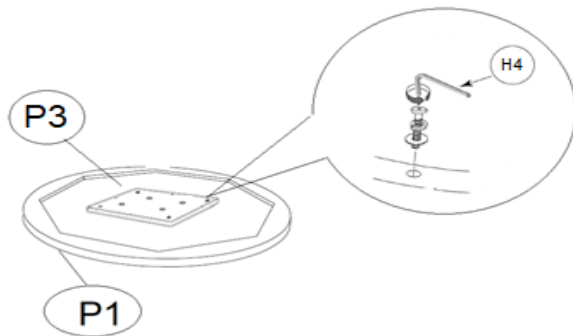



Detach the Mounting Panel (P3) from the Table Top (P1) before assembling the table .

STEP 2

Attach the Mounting Panel (P3) to the Table Pedestal Leg (P2) as shown .

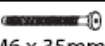
Align the Bolts (H1) fitted with the Spring Washer (H2) . Tighten the Bolts using the Allen Key (H4) .

H1 x 4		M6 x 35mm
H2 x 4		

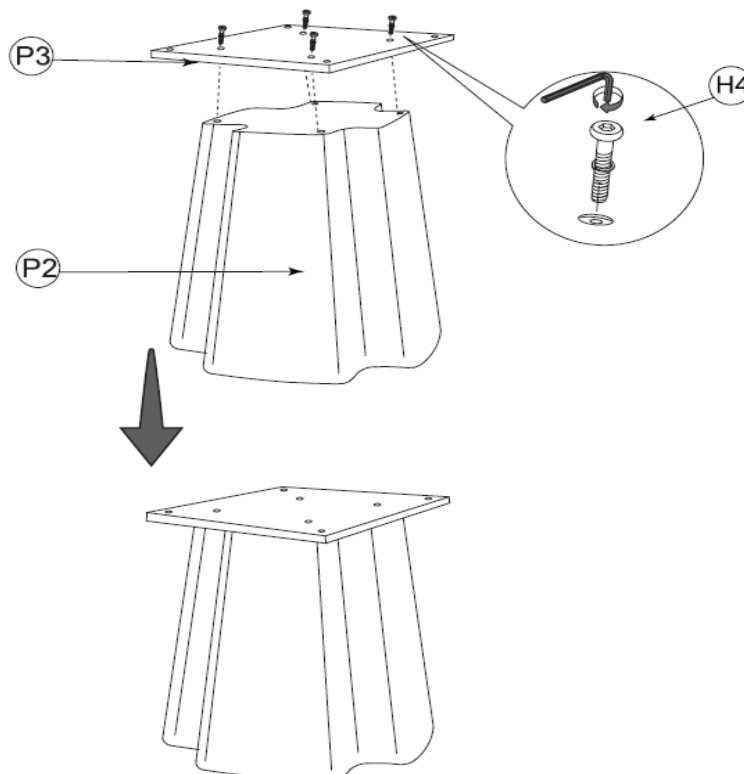





ASSEMBLY INSTRUCTIONS

ROUND DINING TABLE

STEP 3

Attach the Pedestal Leg to the Table Top (P1). Align Bolt (H1) fitted with the Spring Washer (H2) & Flat Washer (H3) through holes in the Mounting Panel (P3) to the nuts in the table top. Tighten the bolts using the Allen Key (H4).

H1 x 4	
M6 x 35mm	
H2 x 4	
H3 x 4	
H5 x 8	

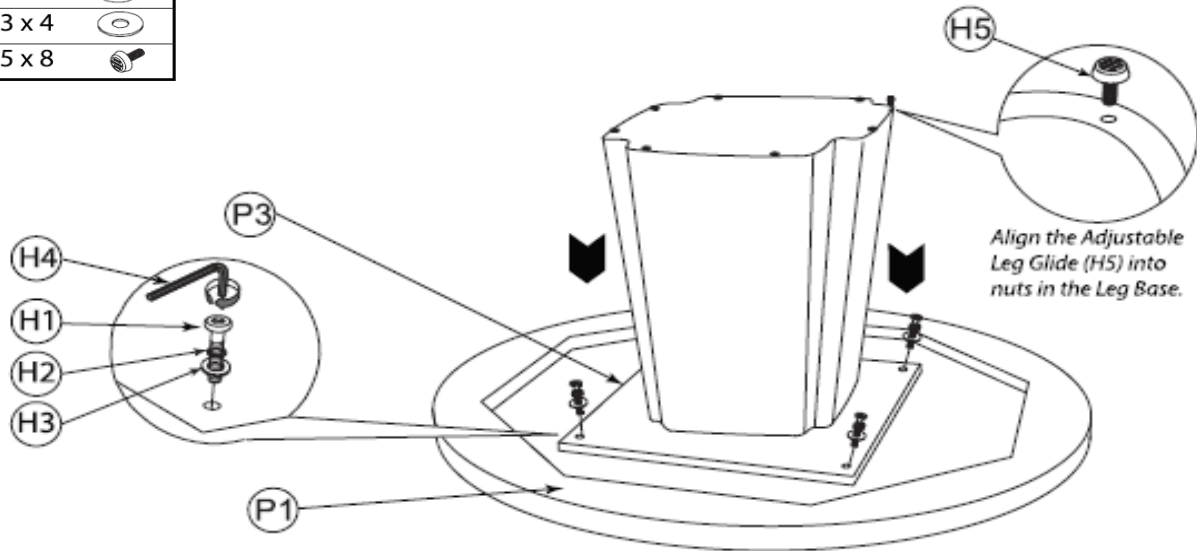

Align the Adjustable Leg Glide (H5) into nuts in the Leg Base.

CAUTION !

AFTER FINISHED ASSEMBLY, CAREFULLY TURN THE TABLE UPRIGHT WITH THE HELP OF TWO OR MORE ADULTS

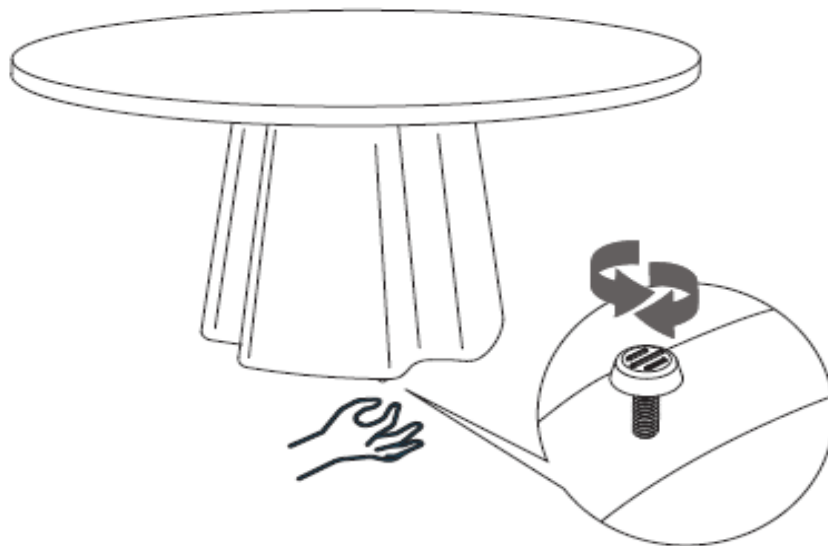

ADJUST THE LEVELERS TO LEVEL THE TABLE

Carefully put the table upright by two or more adults people.

CARE AND MAINTENANCE

SAFETY - To avoid any risk of suffocation to children or animals, dispose off the plastic bags immediately.

CLEANING - Clean with damp cloth and mild detergent. Do not use bleach or abrasive products.

FITTINGS - Tighten bolts and nuts from time to time to ensure all parts of product are securely fitted.

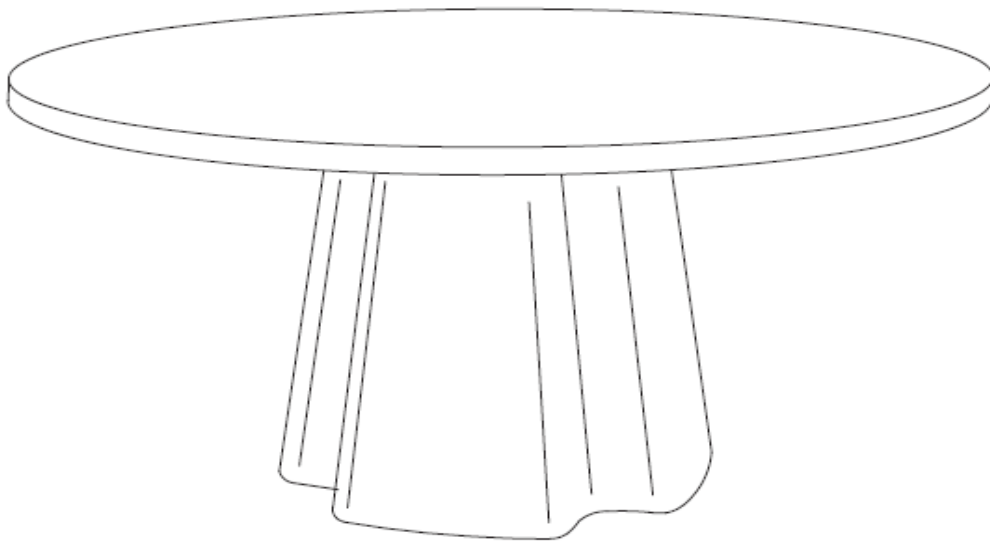

ASSEMBLY COMPLETED



Please ensure the furniture rests on an even and flat surface. If the product wobbles or feels loose, double-check all bolts and/or screws are properly tightened and secured.



Keep this handy!

Please retain this instruction manual and any order-related information for future reference.



Lift, don't drag!

To avoid damage to product please always LIFT the product when transporting or adjusting the placement.

This product is intended for RESIDENTIAL USE ONLY and not for commercial use .

CARE AND MAINTENANCE

SAFETY - To avoid any risk of suffocation to children or animals, dispose off the plastic bags immediately.

CLEANING - Clean with damp cloth and mild detergent. Do not use bleach or abrasive products.

FITTINGS - Tighten bolts and nuts from time to time to ensure all parts of product are securely fitted.