

**Entertainment Cart  
Chariot de divertissement  
Carrito Para Entretener**

**IMPORTANT!-IMPORTANT!-IMPORTANTE!**

Please provide Control No. to ensure replacement parts properly fit unit on hand.  
Fournir N° de contrôle pour assurer que les pièces de rechange s'adaptent correctement à l'unité en question.

Favor de proporcionar el numero de control para garantizar que las piezas de reemplazo ajuste correctame su producto.

Reason of replacement - Raison de remplacement - Razón del reemplazo:

Name - Nom - Nombre

Address - Adresse - Dirección

City/State/Zip - Ville/Province/Code postal - Ciudad/Estado/Zona Postal

Phone - Téléphone - Teléfono

Email

**"Check-list/Part Replacement request" - « Liste de contrôle/Demande de remplacement de pièce »**

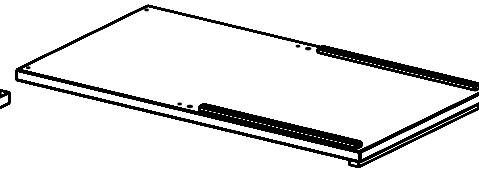
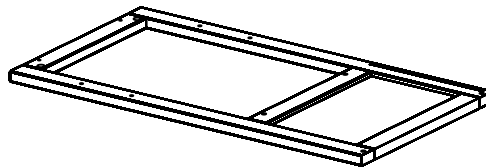
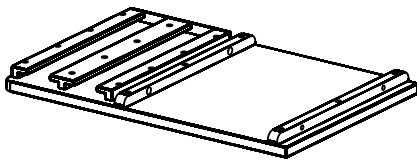

<b>A</b>	<i>Top Le dessus Tapa</i>		
Quantity Quantité Cantidad	1	Missing Manquant Ausente	

<b>B</b>	<i>Left Panel Panneau gauche Panel izquierdo</i>		
Quantity Quantité Cantidad	1	Missing Manquant Ausente	

<b>C</b>	<i>Middle Panel Panneau (milieu) Panel (medio)</i>		
Quantity Quantité Cantidad	1	Missing Manquant Ausente	

<b>D</b>	<i>Bottom Panel Panneau inférieur Panel de abajo</i>		
Quantity Quantité Cantidad	1	Missing Manquant Ausente	

# IMPORTANT!-IMPORTANT!-IMPORTANTE!

Please provide Control No. to ensure replacement parts properly fit unit on hand.  
 Fournir N° de contrôle pour assurer que les pièces de rechange s'adaptent correctement à l'unité en question.  
 Favor de proporcionar el numero de control para garantizar que las piezas de reemplazo ajuste correctame su producto

Name - Nom - Nombre _____ Address - Adresse - Dirección _____ City/State/Zip - Ville/Province/Code postal - Ciudad/Estado/Zona Postal _____	Reason of replacement - Raison de remplacement Razón del reemplazo: _____ _____ _____
Phone - Téléphone - Teléfono _____ Email _____	

## “Check-list/Part Replacement request” - « Liste de contrôle/Demande de remplacement de pièce »

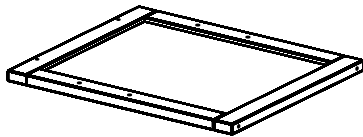

<b>E</b>	Right Panel (Upper) Panneau droit (supérieur) Costado derecho (superior)		
Quantity Quantité Cantidad	1	Missing Manquant Ausente	

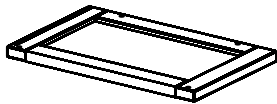

<b>F</b>	Right Panel (Lower) Panneau droit (inférieur) Costado derecho (de abajo)		
Quantity Quantité Cantidad	1	Missing Manquant Ausente	

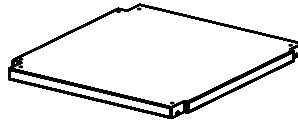

<b>G</b>	Shelf Étagère Entrepañó		
Quantity Quantité Cantidad	1	Missing Manquant Ausente	



<b>H</b>	Left Door Porte gauche Puerta izquierda		
Quantity Quantité Cantidad	1	Missing Manquant Ausente	

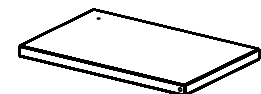

<b>I</b>	Right Door Porte droit Puerta derecha		
Quantity Quantité Cantidad	1	Missing Manquant Ausente	

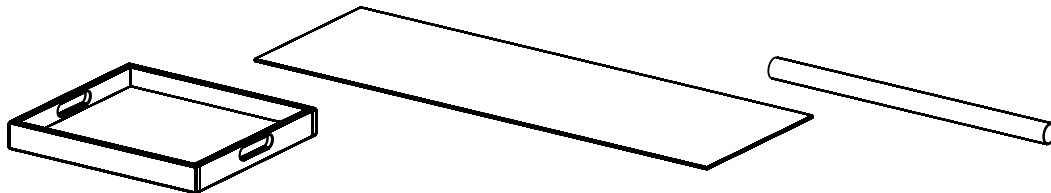

<b>J</b>	Tray Plateau Bandeja		
Quantity Quantité Cantidad	1	Missing Manquant Ausente	

<b>K</b>	Back Panel Panneau arrière Panel Posterior		
Quantity Quantité Cantidad	1	Missing Manquant Ausente	

<b>L</b>	Handle Poignée Manejar		
Quantity Quantité Cantidad	1	Missing Manquant Ausente	

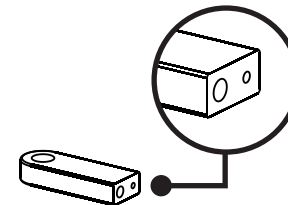

<b>M1</b>	Left Handle Support Support de poignée gauche Soporte del manejar izquierdo		
Quantity Quantité Cantidad	1	Missing Manquant Ausente	

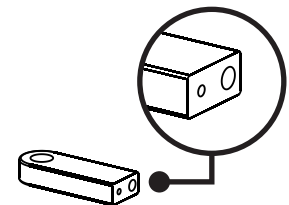





<b>M2</b>	Right Handle Support Support de poignée droite Soporte del manejar derecha		
Quantity Quantité Cantidad	1	Missing Manquant Ausente	

# IMPORTANT!-IMPORTANT!-IMPORTANTE!

Please provide Control No. to ensure replacement parts properly fit unit on hand.  
 Fournir N° de contrôle pour assurer que les pièces de rechange s'adaptent correctement à l'unité en question.  
 Favor de proporcionar el numero de control para garantizar que las piezas de reemplazo ajuste correctame su producto

<p>Name - Nom - Nombre</p> <hr/> <p>Address - Adresse - Dirección</p> <hr/> <p>City/State/Zip - Ville/Province/Code postal - Ciudad/Estado/Zona Postal</p> <hr/>	<p>Reason of replacement - Raison de remplacement                  Razón del reemplazo:</p> <hr/> <hr/> <hr/>
<p>Phone - Téléphone - Teléfono</p> <hr/>	
<p>Email</p> <hr/>	

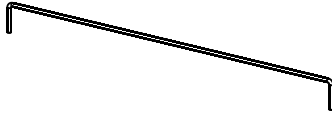
## “Check-list/Part Replacement request” - « Liste de contrôle/Demande de remplacement de pièce »

																								
<p><b>N1</b> Metal Rail (Short) Barre en métal (court) Riel de metal (corto)</p> <table border="1" style="width:100%; border-collapse: collapse;"> <tr> <td>Quantity Quantité Cantidad</td> <td>2</td> <td>Missing Manquant Ausente</td> <td></td> </tr> </table>	Quantity Quantité Cantidad	2	Missing Manquant Ausente		<p><b>N2</b> Metal Rail (Medium) Barre en métal (moyen) Riel de metal (mediano)</p> <table border="1" style="width:100%; border-collapse: collapse;"> <tr> <td>Quantity Quantité Cantidad</td> <td>4</td> <td>Missing Manquant Ausente</td> <td></td> </tr> </table>	Quantity Quantité Cantidad	4	Missing Manquant Ausente		<p><b>N3</b> Metal Rail (Long) Barre en métal (Long) Riel de metal (Largo)</p> <table border="1" style="width:100%; border-collapse: collapse;"> <tr> <td>Quantity Quantité Cantidad</td> <td>2</td> <td>Missing Manquant Ausente</td> <td></td> </tr> </table>	Quantity Quantité Cantidad	2	Missing Manquant Ausente		<p><b>O1</b> Locking Caster Roulette à verrouillage Rueda con cerrójo</p> <table border="1" style="width:100%; border-collapse: collapse;"> <tr> <td>Quantity Quantité Cantidad</td> <td>2</td> <td>Missing Manquant Ausente</td> <td></td> </tr> </table>	Quantity Quantité Cantidad	2	Missing Manquant Ausente		<p><b>O2</b> Caster Roulette Rueda</p> <table border="1" style="width:100%; border-collapse: collapse;"> <tr> <td>Quantity Quantité Cantidad</td> <td>2</td> <td>Missing Manquant Ausente</td> <td></td> </tr> </table>	Quantity Quantité Cantidad	2	Missing Manquant Ausente	
Quantity Quantité Cantidad	2	Missing Manquant Ausente																						
Quantity Quantité Cantidad	4	Missing Manquant Ausente																						
Quantity Quantité Cantidad	2	Missing Manquant Ausente																						
Quantity Quantité Cantidad	2	Missing Manquant Ausente																						
Quantity Quantité Cantidad	2	Missing Manquant Ausente																						
<p><b>P</b> Wood Dowel Goujon en bois Clavija de madera</p> <table border="1" style="width:100%; border-collapse: collapse;"> <tr> <td>Quantity Quantité Cantidad</td> <td>2</td> <td>Missing Manquant Ausente</td> <td></td> </tr> </table>	Quantity Quantité Cantidad	2	Missing Manquant Ausente		<p><b>Q</b> Metal Pin Cheville en métal Clavija de metal</p> <table border="1" style="width:100%; border-collapse: collapse;"> <tr> <td>Quantity Quantité Cantidad</td> <td>8</td> <td>Missing Manquant Ausente</td> <td></td> </tr> </table>	Quantity Quantité Cantidad	8	Missing Manquant Ausente		<p><b>R</b> Wood Plug Chevilles en bois Tapón de madera</p> <table border="1" style="width:100%; border-collapse: collapse;"> <tr> <td>Quantity Quantité Cantidad</td> <td>8</td> <td>Missing Manquant Ausente</td> <td></td> </tr> </table>	Quantity Quantité Cantidad	8	Missing Manquant Ausente		<p><b>S</b> Magnet Aimant Imán</p> <table border="1" style="width:100%; border-collapse: collapse;"> <tr> <td>Quantity Quantité Cantidad</td> <td>2</td> <td>Missing Manquant Ausente</td> <td></td> </tr> </table>	Quantity Quantité Cantidad	2	Missing Manquant Ausente		<p><b>T</b> Knob Bouton Perilla</p> <table border="1" style="width:100%; border-collapse: collapse;"> <tr> <td>Quantity Quantité Cantidad</td> <td>2</td> <td>Missing Manquant Ausente</td> <td></td> </tr> </table>	Quantity Quantité Cantidad	2	Missing Manquant Ausente	
Quantity Quantité Cantidad	2	Missing Manquant Ausente																						
Quantity Quantité Cantidad	8	Missing Manquant Ausente																						
Quantity Quantité Cantidad	8	Missing Manquant Ausente																						
Quantity Quantité Cantidad	2	Missing Manquant Ausente																						
Quantity Quantité Cantidad	2	Missing Manquant Ausente																						
<p><b>U</b> Hex Screw Vis Hex Tornillo Hex</p> <table border="1" style="width:100%; border-collapse: collapse;"> <tr> <td>Quantity Quantité Cantidad</td> <td>16</td> <td>Missing Manquant Ausente</td> <td></td> </tr> </table>	Quantity Quantité Cantidad	16	Missing Manquant Ausente		<p><b>V</b> Screw* (Caster) Vis* (roulette) Tornillo* (rueda)</p> <table border="1" style="width:100%; border-collapse: collapse;"> <tr> <td>Quantity Quantité Cantidad</td> <td>16</td> <td>Missing Manquant Ausente</td> <td></td> </tr> </table>	Quantity Quantité Cantidad	16	Missing Manquant Ausente		<p><b>W</b> Screw* (Magnet) Vis* (Aimant) Tornillo* (Imán)</p> <table border="1" style="width:100%; border-collapse: collapse;"> <tr> <td>Quantity Quantité Cantidad</td> <td>4</td> <td>Missing Manquant Ausente</td> <td></td> </tr> </table>	Quantity Quantité Cantidad	4	Missing Manquant Ausente		<p><b>X</b> Bolt* Boulon* Tornillo de metal*</p> <table border="1" style="width:100%; border-collapse: collapse;"> <tr> <td>Quantity Quantité Cantidad</td> <td>2</td> <td>Missing Manquant Ausente</td> <td></td> </tr> </table>	Quantity Quantité Cantidad	2	Missing Manquant Ausente		<p><b>Wrench</b> Clé Llave</p> <table border="1" style="width:100%; border-collapse: collapse;"> <tr> <td>Quantity Quantité Cantidad</td> <td>1</td> <td>Missing Manquant Ausente</td> <td></td> </tr> </table>	Quantity Quantité Cantidad	1	Missing Manquant Ausente	
Quantity Quantité Cantidad	16	Missing Manquant Ausente																						
Quantity Quantité Cantidad	16	Missing Manquant Ausente																						
Quantity Quantité Cantidad	4	Missing Manquant Ausente																						
Quantity Quantité Cantidad	2	Missing Manquant Ausente																						
Quantity Quantité Cantidad	1	Missing Manquant Ausente																						

Assembly Instructions - Instructions d'assemblage - Instrucciones de ensamblaje

1

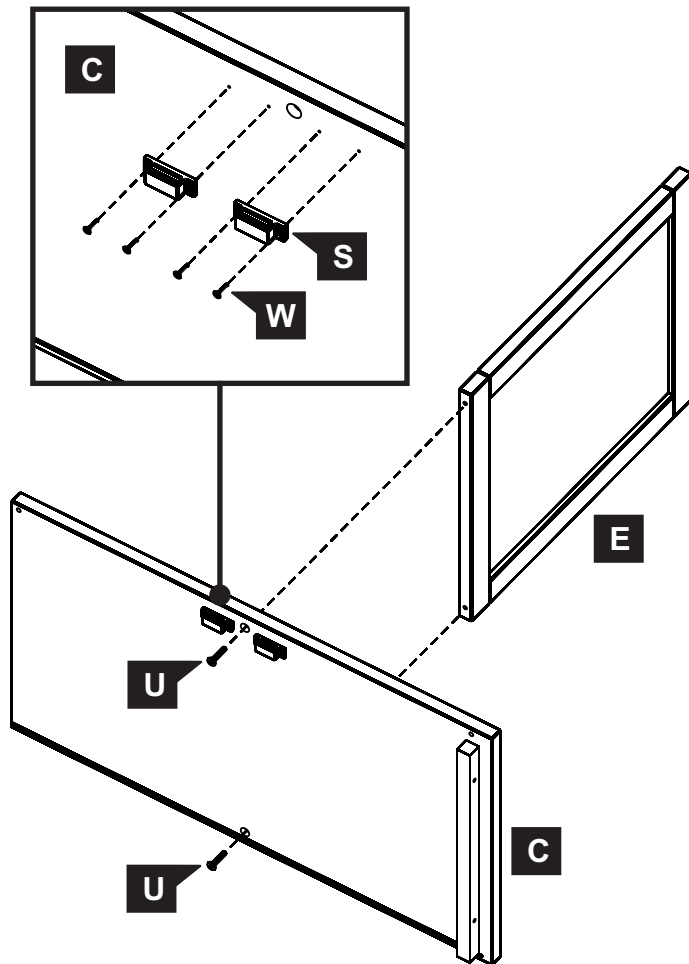

2

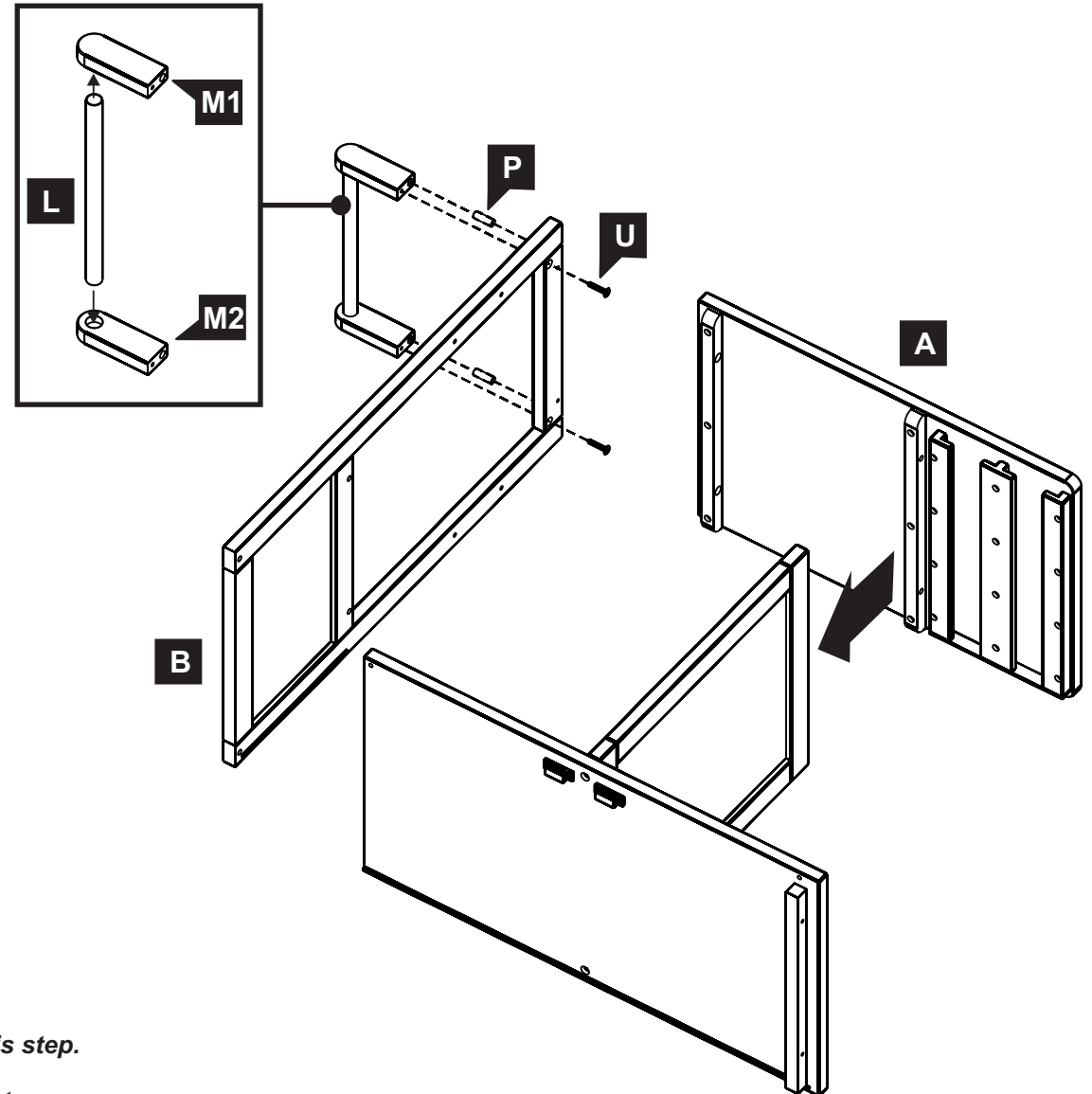

*Tip: Recommend to have helping hands for this step.*  
*Conseil : demandez de l'aide pour cette étape.*  
*Consejo: Se recomienda que le ayuden para este paso.*

Assembly Instructions - Instructions d'assemblage - Instrucciones de ensamblaje

3

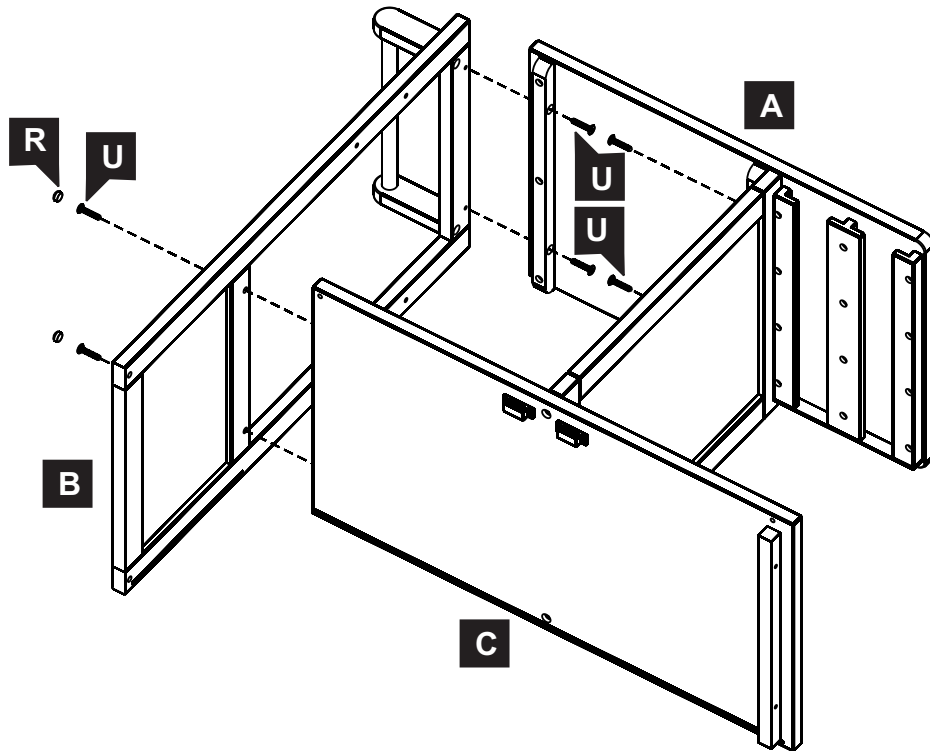

4

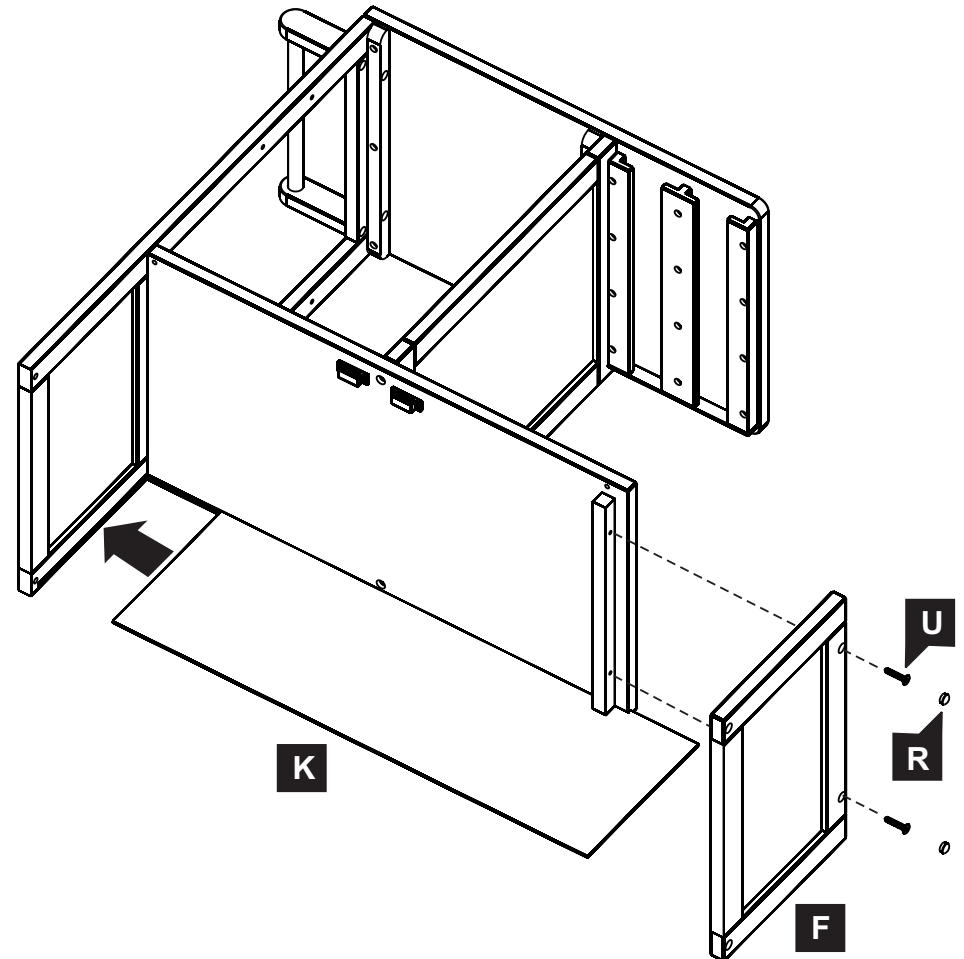

**\*\* Tip: Insert wood plugs after finishing assembling the unit.**

**\*\* Conseil: fixer les tampons de bois après avoir assemblé l'unité.**

**\*\* Consejo: ponga los tapones de madera después de la asamblea de la unidad.**

Assembly Instructions - Instructions d'assemblage - Instrucciones de ensamblaje

5

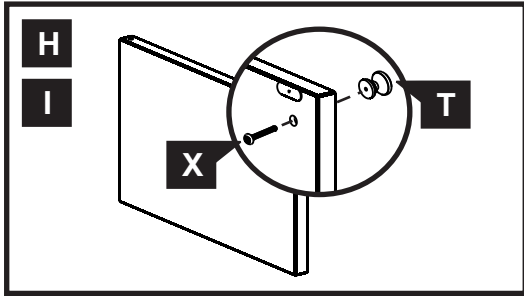

6

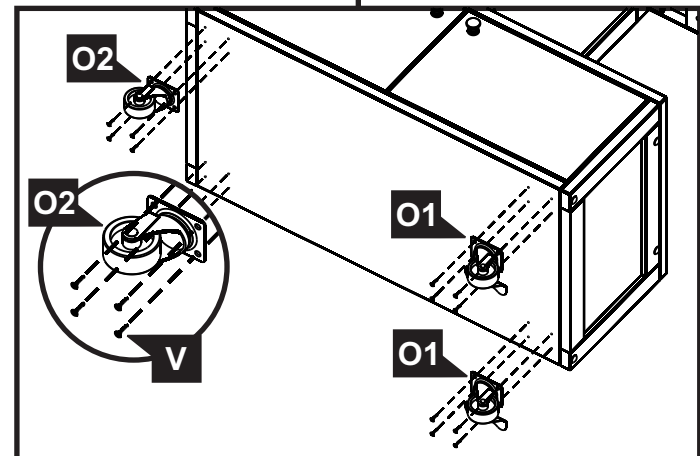
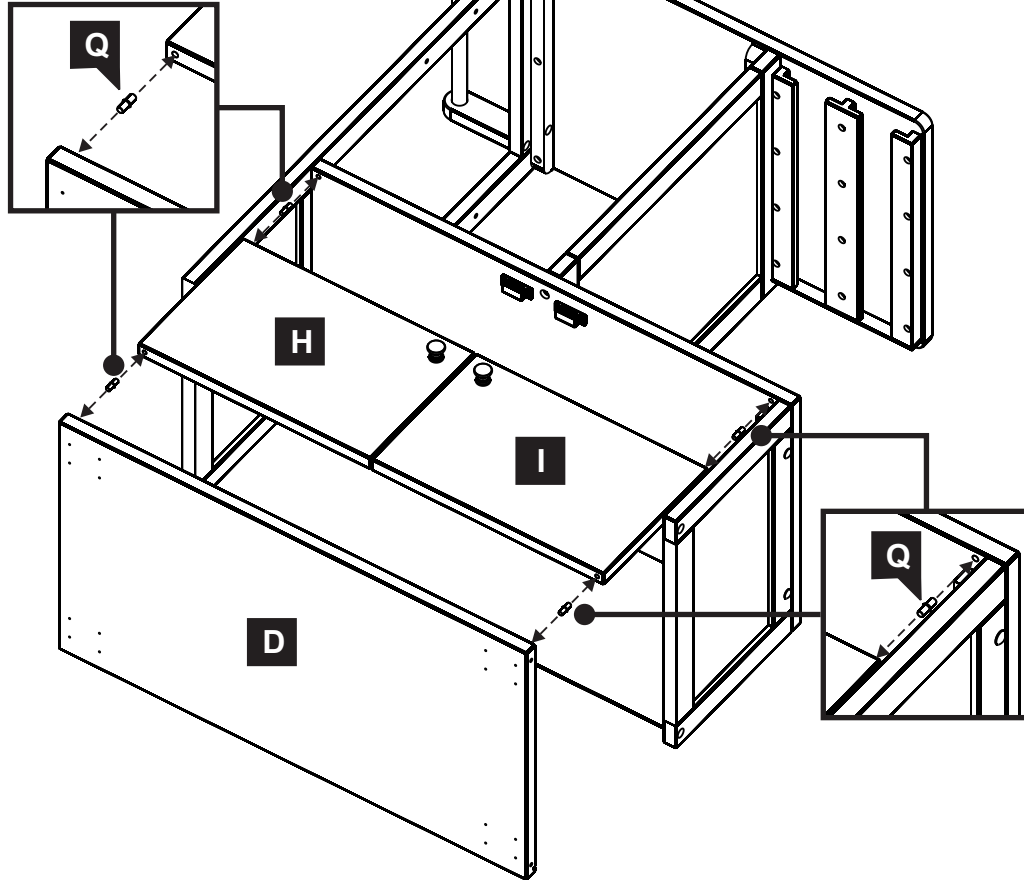
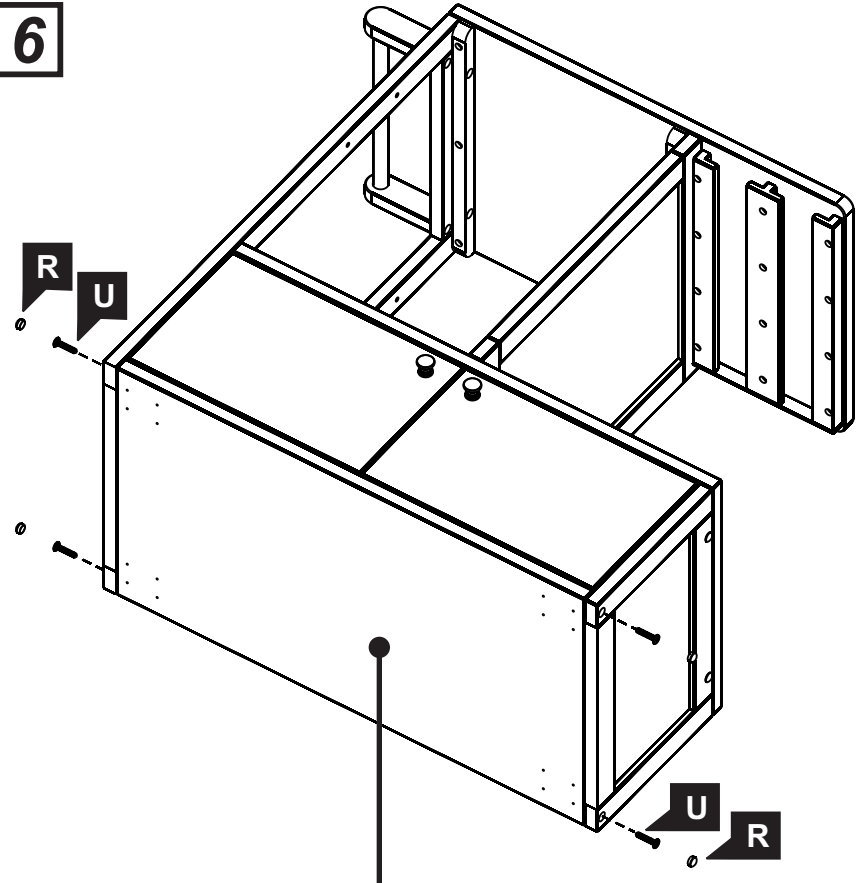

7

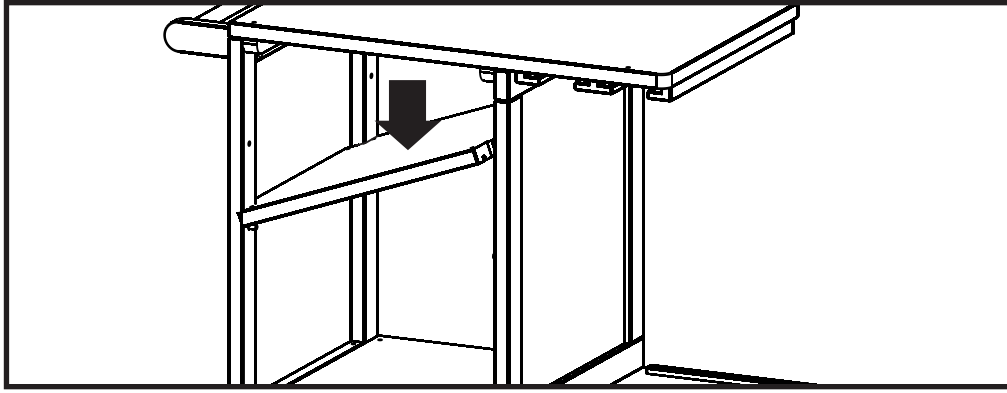
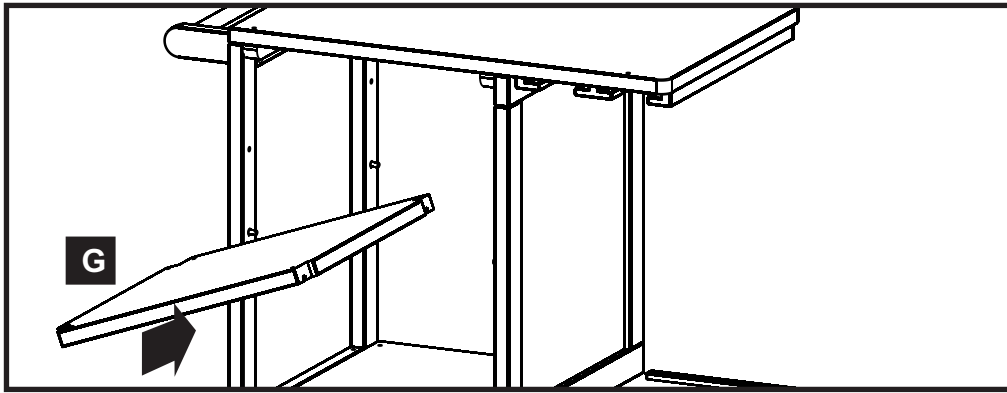
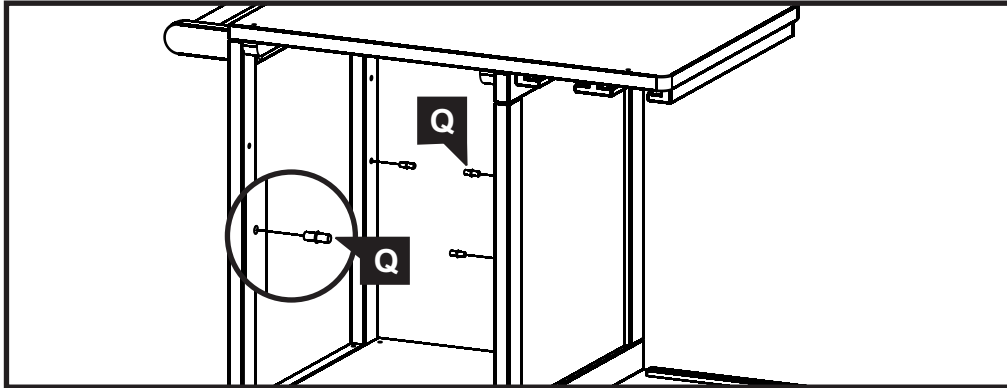

Assembly Instructions - Instructions d'assemblage - Instrucciones de ensamblaje

8

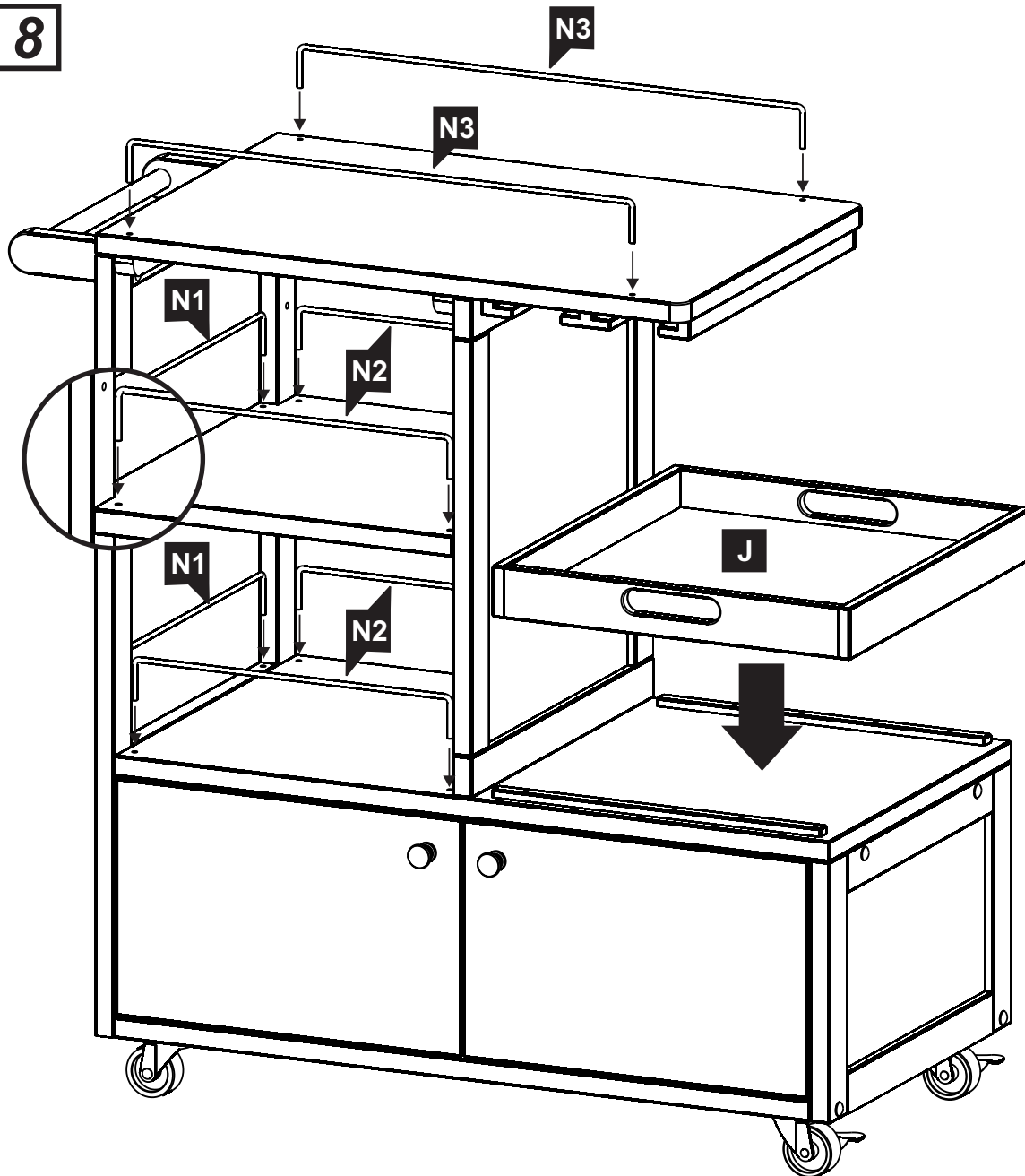

**Care instructions:**

Proper care and treatment are essential to preserve the natural beauty of this wood product. To clean wood surfaces, wipe with wet cloth and dry thoroughly. Use mild soap if necessary. Occasional mineral oil treatment will revitalize wood. Use good furniture oil and follow manufacturer's instruction for application. Avoid use of commercial waxes or polishes, glass cleaners or abrasive cleaning materials.

**Instructions d'entretien:**

Il est très important de bien entretenir et de bien traiter ce produit en bois pour en préserver la beauté naturelle. Pour nettoyer les surfaces en bois, essuyez avec un linge humide et séchez à fond. Utilisez un savon doux au besoin. Un traitement occasionnel avec de l'huile minérale revitalisera le bois. Utilisez une bonne huile à meuble et suivez les instructions du fabricant pour l'application. Évitez d'utiliser des cires ou produits à polir de type commercial, des produits pour vitres ou des matériaux de nettoyage abrasifs.

**Instrucciones para el cuidado:**

Cuidado y trato apropiado son esenciales para preservar la belleza natural de este producto de madera. Para limpiar las superficies de madera, frótelas con algo húmedo y séquelas bien. Use un jabón suave si es necesario. Un tratamiento ocasional con aceite mineral revitalizará la madera. Use un buen aceite para muebles y siga las instrucciones del fabricante para aplicarlo. Evite el uso de ceras o pulidores comerciales, limpiadores de cristales o materiales abrasivos.