

INSTALLATION

Product Manual

Version: 200066EU-00-25A-XN

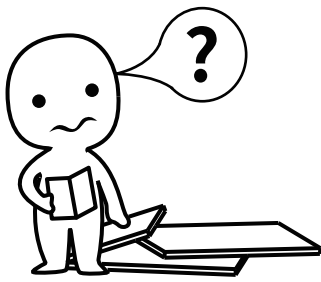

IMPORTANT INFORMATION!

please read the entire manual before starting to assemble and/or using this product. follow the manual thoroughly and keep it for further reference.

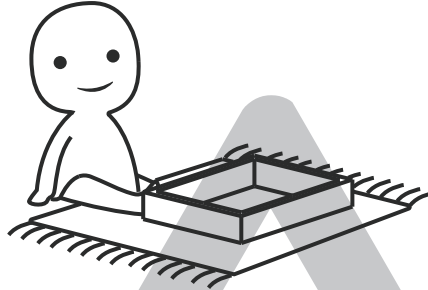
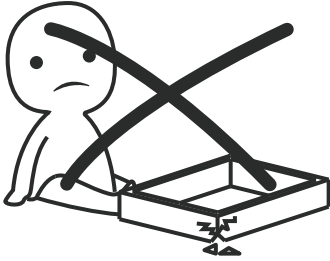

AVOID SCRATCHES!

In order to avoid scratching this furniture should be assembled on a soft layer- could be a rug.

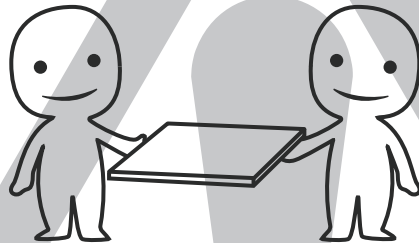

IMPROVE EFFICIENCY !

Try to find a partner to install with you, which can speed up the installation efficiency and shorten the time.

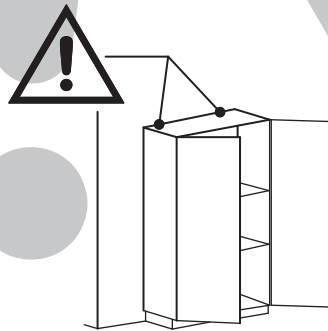
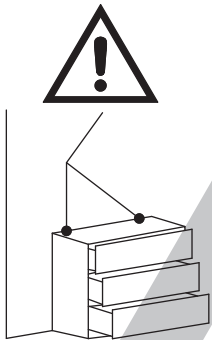

ANTI-TOPPLE WARNING !

Overtured furniture can cause serious or fatal crush injuries. To prevent tipping over, be sure to use the wall attachment, if not included with this product. Please purchase the wall attachment that fit your wall. If unsure, seek professional advice. Please read and follow each step of the instructions carefully.

IMPORTANT !

It is important that any product which is assembled using any kind of screw is re-tightened 2 weeks after assembly, and once every 3 months - in order to assure stability through-out the lifespan of the product.

For regular maintenance and cleaning of the product, for the frame, please use a rag dipped in neutral detergent to fully wipe it, and then dry it with a clean rag. For glass materials, wipe with a rag dampened with water glass cleaner, and then dry with a dry rag.

Do not use an electric screwdriver, and do not use too much force when installing, because the board is easy to break.



AVERTISSEMENT!

Veillez lire le manuel en entier avant de commencer à assembler et/ou à utiliser ce produit. suivez attentivement le manuel et conservez-le pour référence ultérieure.

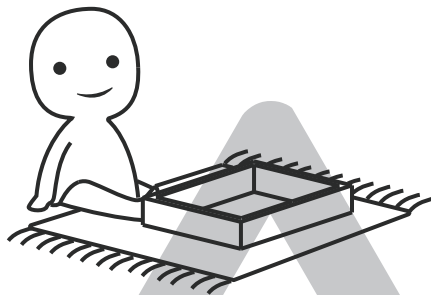
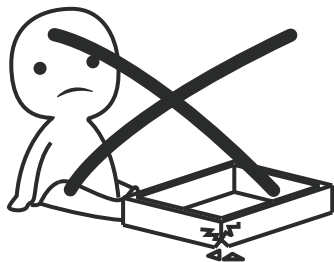

ÉVITEZ LES RAYURES!

Afin d'éviter de rayer ce meuble doit être assemblé sur une couche souple - pourrait être un tapis

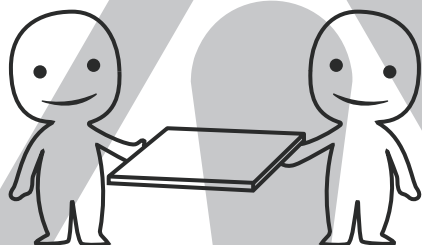

AMÉLIORER L'EFFICACITÉ !

Essayez de trouver un partenaire à installer avec vous, ce qui peut accélérer l'efficacité de l'installation et raccourcir le temps.

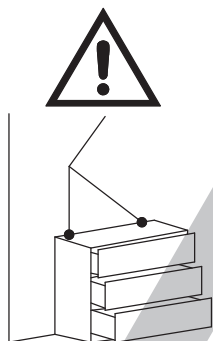

AVERTISSEMENT ANTI-RENVERSEMENT !

Les meubles renversés peuvent causer des blessures graves ou mortelles par écrasement. Pour éviter de basculer, assurez-vous d'utiliser la fixation murale, si elle n'est pas incluse avec le produit. Veillez acheter la fixation murale qui s'adapte à votre mur. En cas de doute, demandez conseil à un professionnel. Veillez lire et suivre attentivement chaque étape des instructions.

IMPORTANT !

Il est important que tout produit assemblé à l'aide de tout type de vis soit resserré 2 semaines après l'assemblage et une fois tous les 3 mois, afin d'assurer la stabilité tout au long de la durée de vie du produit.

Pour l'entretien régulier et le nettoyage du produit, pour le cadre, veuillez utiliser un chiffon trempé dans un détergent neutre pour l'essuyer complètement, puis séchez-le avec un chiffon propre. Pour les matériaux en verre, essuyez avec un chiffon imbibé d'eau nettoyant pour vitres, puis séchez avec un chiffon sec.

N'utilisez pas de tournevis électrique et n'utilisez pas trop de force lors de l'installation, car la carte est facile à casser.

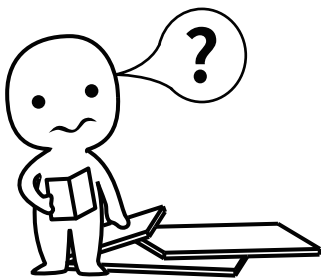

WARNEN!

Bitte lesen Sie das gesamte Handbuch, bevor Sie mit der Montage und /oder Verwendung dieses Produkts beginnen. Befolgen Sie das Handbuch sorgfältig und bewahren Sie es zum späteren Nachschlagen auf.

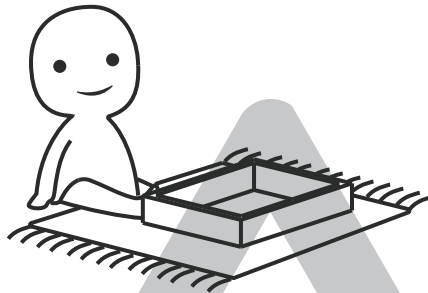
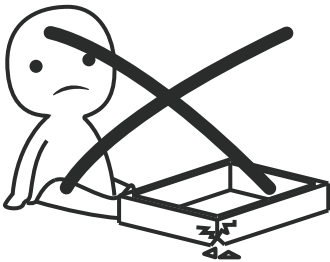

KRATZER VERMEIDEN!

Um Kratzer zu vermeiden, sollten diese Möbel auf einer weichen Schicht montiert werden - könnte ein Teppich sein.

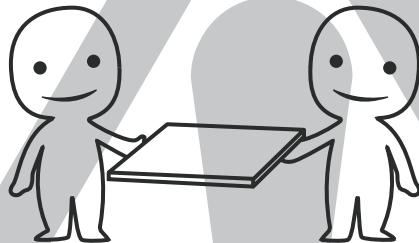

EFFIZIENZ STEIGERN !

Versuchen Sie, Partner zu finden, um mit Ihnen zu installieren, was die Installationseffizienz beschleunigen und die Zeit verkürzen kann.

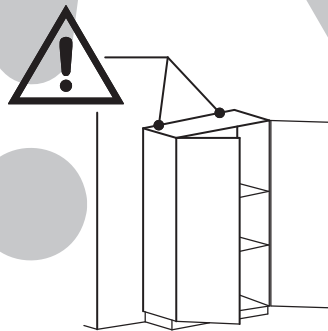
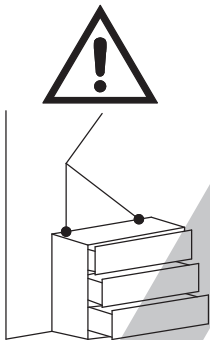

ANTI-TOPPLE-WARNUNG !

Umgestürzte Möbel können schwere oder tödliche Quetschverletzungen verursachen. Um ein Umkippen zu vermeiden, achten Sie darauf, die Wandbefestigung zu verwenden, wenn sie nicht im Lieferumfang enthalten ist. Bitte kaufen Sie den Wandaufsatz, der zu Ihrer Wand passt. Wenn Sie sich nicht sicher sind, suchen Sie professionellen Rat. Bitte lesen und befolgen Sie jeden Schritt der Anweisungen sorgfältig.

WICHTIG !

Es ist wichtig, dass jedes Produkt, das mit irgendeiner Art von Schraube montiert wird, 2 Wochen nach der Montage und einmal alle 3 Monate wieder angezogen wird, um die Stabilität während der gesamten Lebensdauer des Produkts zu gewährleisten.

Verwenden Sie für die regelmäßige Wartung und Reinigung des Produkts für den Rahmen einen Lappen, der in ein neutrales Reinigungsmittel getaucht ist, um ihn vollständig abzuwischen, und trocknen Sie ihn dann mit einem sauberen Lappen.



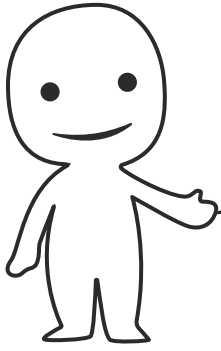



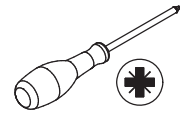
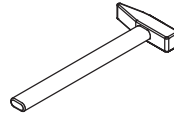
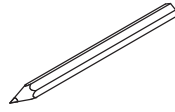

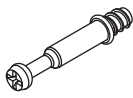

Verwenden Sie keinen Elektroschraubendreher und verwenden Sie nicht zu viel Kraft bei der Installation, da das Board leicht zu brechen ist.

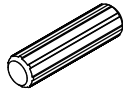
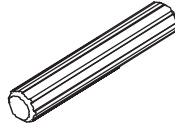
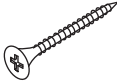

Please prepare the following tools

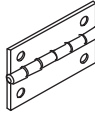

When installing, please carefully confirm whether each screw corresponds to the manual, accessories with similar shapes can be distinguished by size

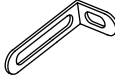
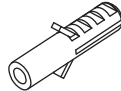
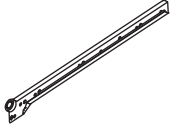
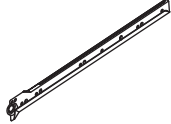
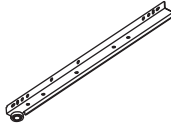
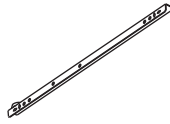
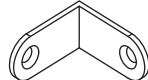
A x 52  Ø 6 x 35 mm	B x 52  Ø 15 x 10 mm	C x 24  Ø 6 x 30 mm	D x 1  Ø 6 x 50 mm	E x 35  Ø 4 x 35 mm
F x 50  Ø 3 x 12 mm	G x 9  Ø 4 x 25 mm	H x 8  Ø 3 x 14 mm	I x 2 	J x 16  Ø 3 x 16 mm
K x 16 	L x 9 	M x 2  Ø 4 x 14 mm	N x 1 	O x 1  Ø 6 x 30 mm
CR x 5  350mm	CL x 5  350mm	DR x 5  350mm	DL x 5  350mm	P x 5 

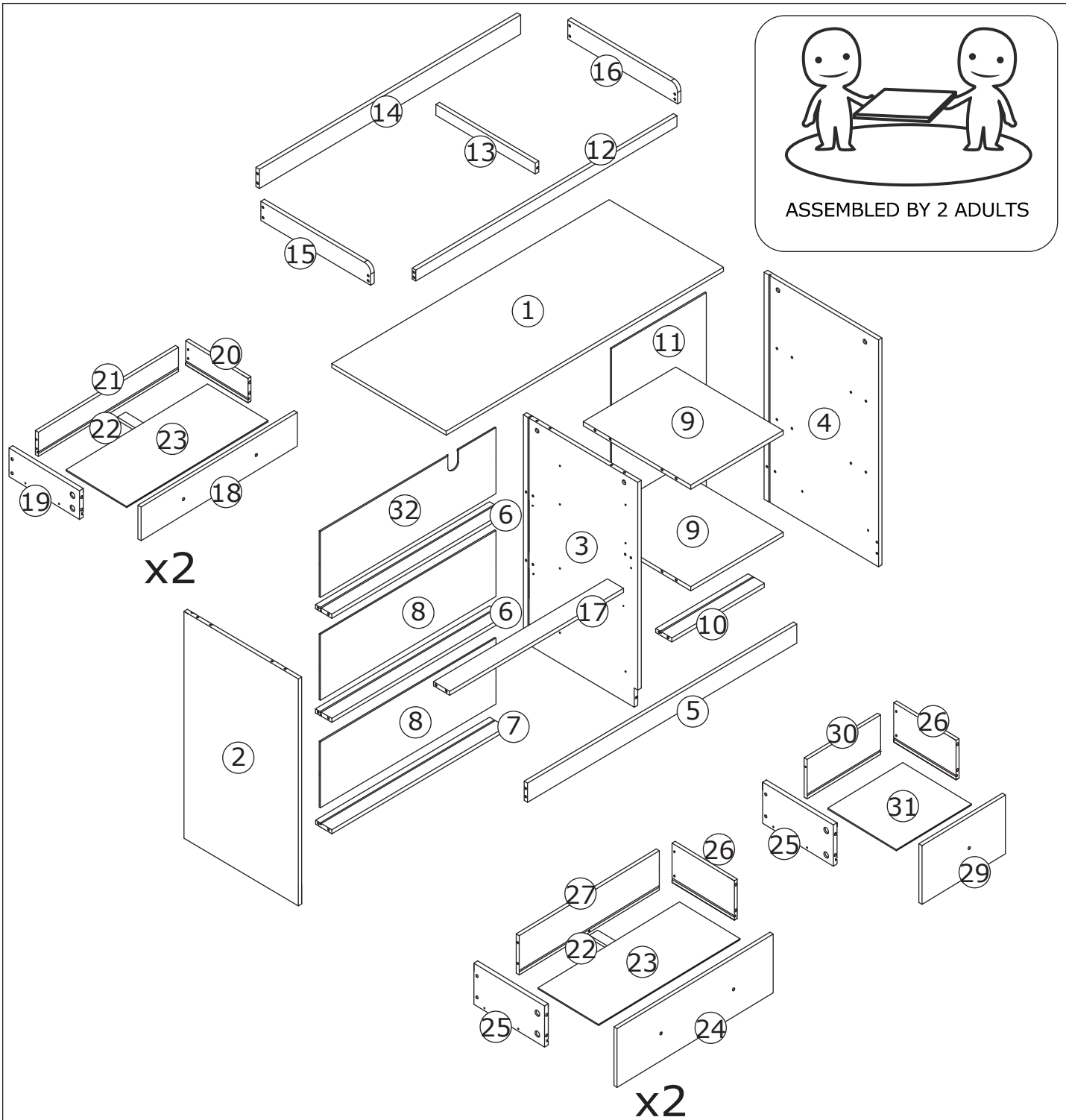

⚠ WARNING

Children have died from furniture tipover. To reduce the risk of furniture tipover:

- ALWAYS install Anti-tip device provided.
- NEVER put a TV on this product.
- NEVER allow children to stand, climb or hang on any drawers, doors, or shelves.
- NEVER open more than one drawer at a time.
- Place heaviest items in the lowest drawers.

*This is a permanent label.
Do not remove!*

1

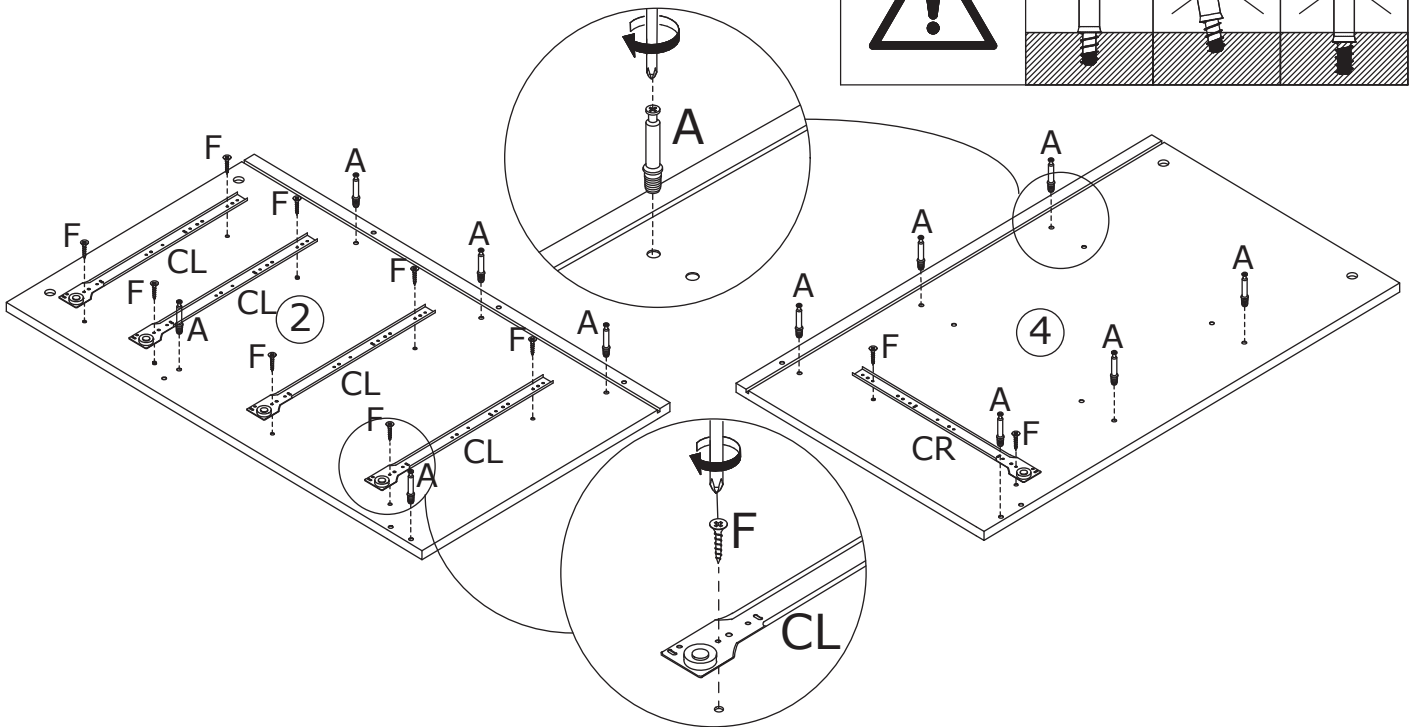
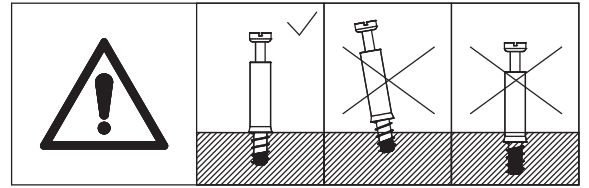
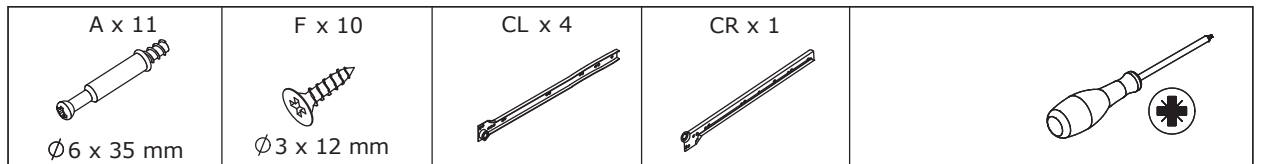



Insert quickfit screw(A) into corresponding holes in No.2 and No.4 plate with a screw driver as shown.
Fix slide rail(CL) and (CR) to No.2 and No.4 plate respectively with screw(F) as shown.
Please pay attention to the holes where the accessories are inserted.

Insérer la vis quickfit (A) dans les trous correspondants des plaques n° 2 et n° 4 à l'aide d'un tournevis comme indiqué.
Fixer les glissières (CL) et (CR) à la plaque No.2 et No.4 respectivement avec la vis(F) comme indiqué.
Veuillez faire attention aux trous dans lesquels les accessoires sont insérés.

Führen Sie die Schnellbauschraube (A) in die entsprechenden Löcher der Platten Nr. 2 und Nr. 4 ein.
mit einem Schraubendreher wie abgebildet ein.
Befestigen Sie die Gleitschiene (CL) und (CR) an der Platte Nr. 2 bzw. Nr. 4 mit der Schraube (F) wie abgebildet.
Achten Sie bitte auf die Löcher, in die das Zubehör eingesetzt wird.

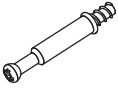
2

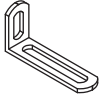
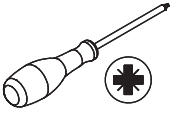
<p>A x 6  Ø6 x 35 mm</p>	<p>M x 2  Ø4 x 14 mm</p>	<p>N x 1 </p>	
---	---	--	---

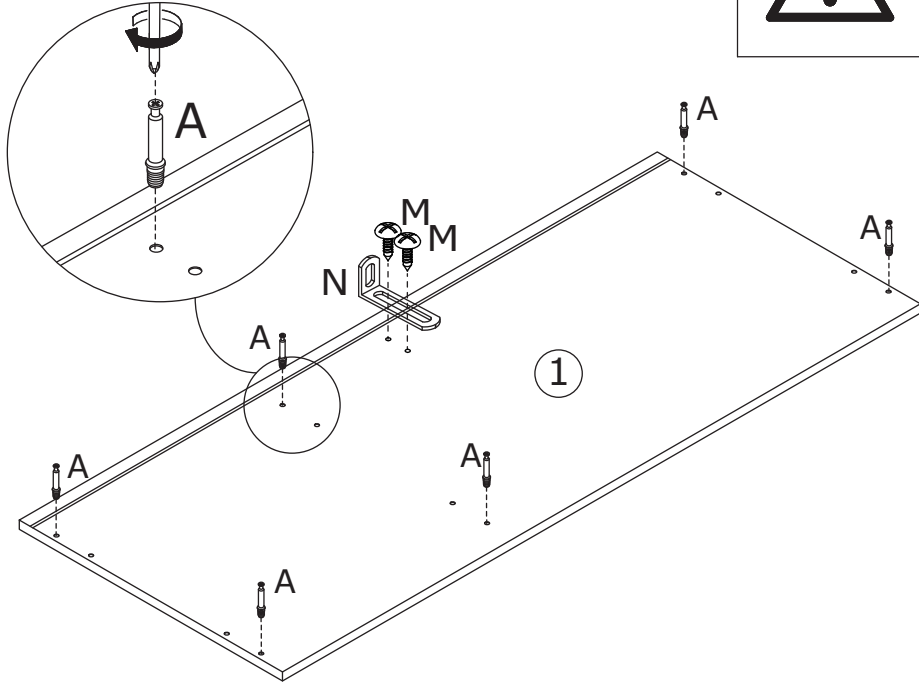
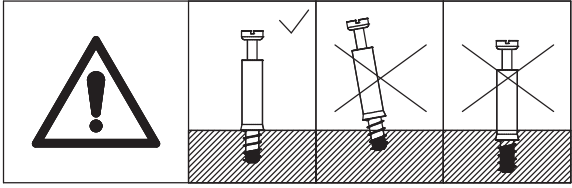

3

<p>A x 1  Ø6 x 35 mm</p>	
---	---

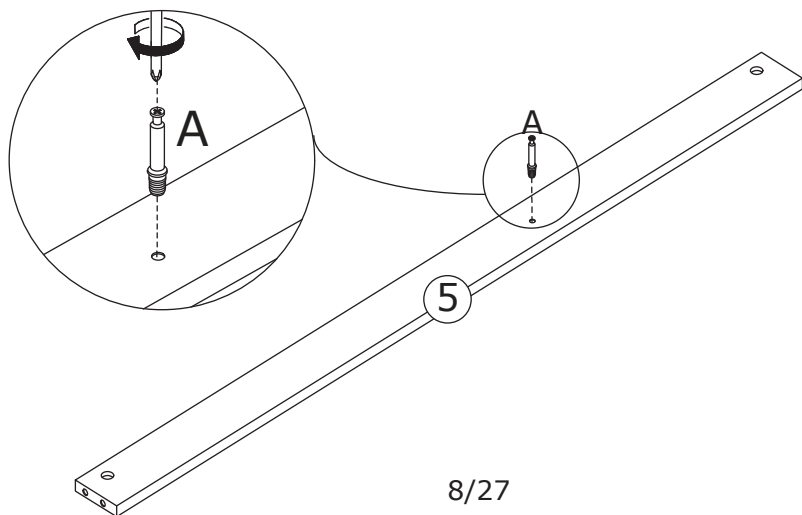
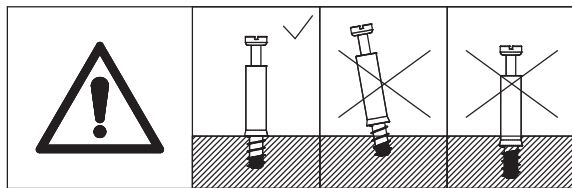

4

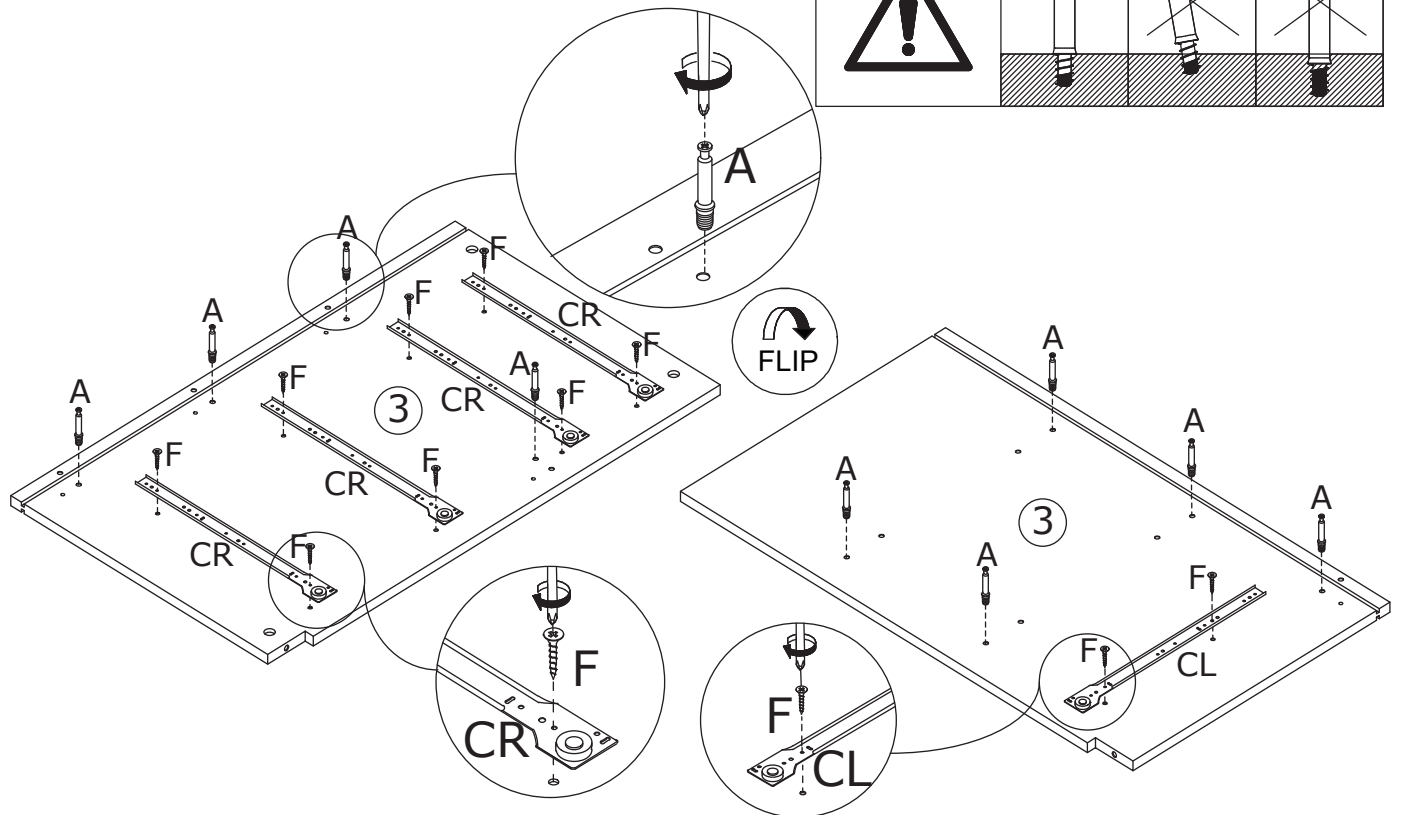
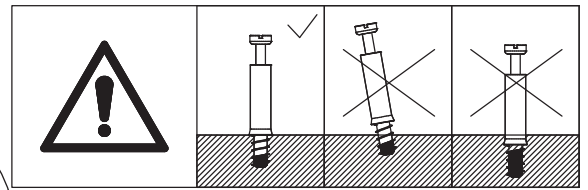
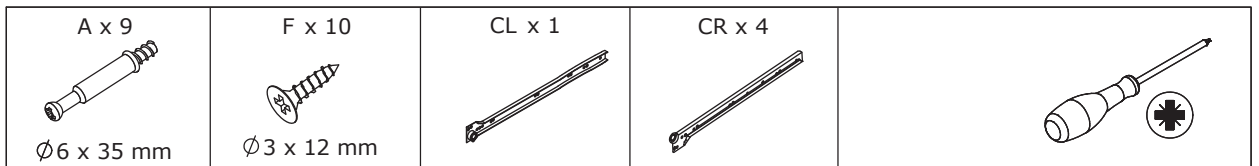

Fix slide rail(CR) to No.3 plate with screw(F) at first.
Flip the plate, fix slide rail(CL) with screw(H) as shown.

Insert quickfit screw(A) into corresponding holes in both A
F sides of No.3 plate as shown.

Befestigen Sie die Gleitschiene (CR) zunächst mit der Schraube (F) an der
Platte Nr. 3.

Drehen Sie die Platte um und befestigen Sie die Gleitschiene (CL) mit der
Schraube (H) wie gezeigt.

Stecken Sie die Schnellbauschrauben (A) in die entsprechenden Löcher
auf beiden A
F der Platte Nr. 3 ein, wie abgebildet.

Fixer la glissière (CR) à la plaque No.3 avec la vis (F) dans un premier
temps.

Retourner la plaque, fixer la glissière (CL) avec la vis (H) comme indiqué.

Insérer la vis quickfit(A) dans les trous correspondants des deux côtés A
F de la plaque No.3 comme indiqué.

5

B x 1
Ø15 x 9 mm

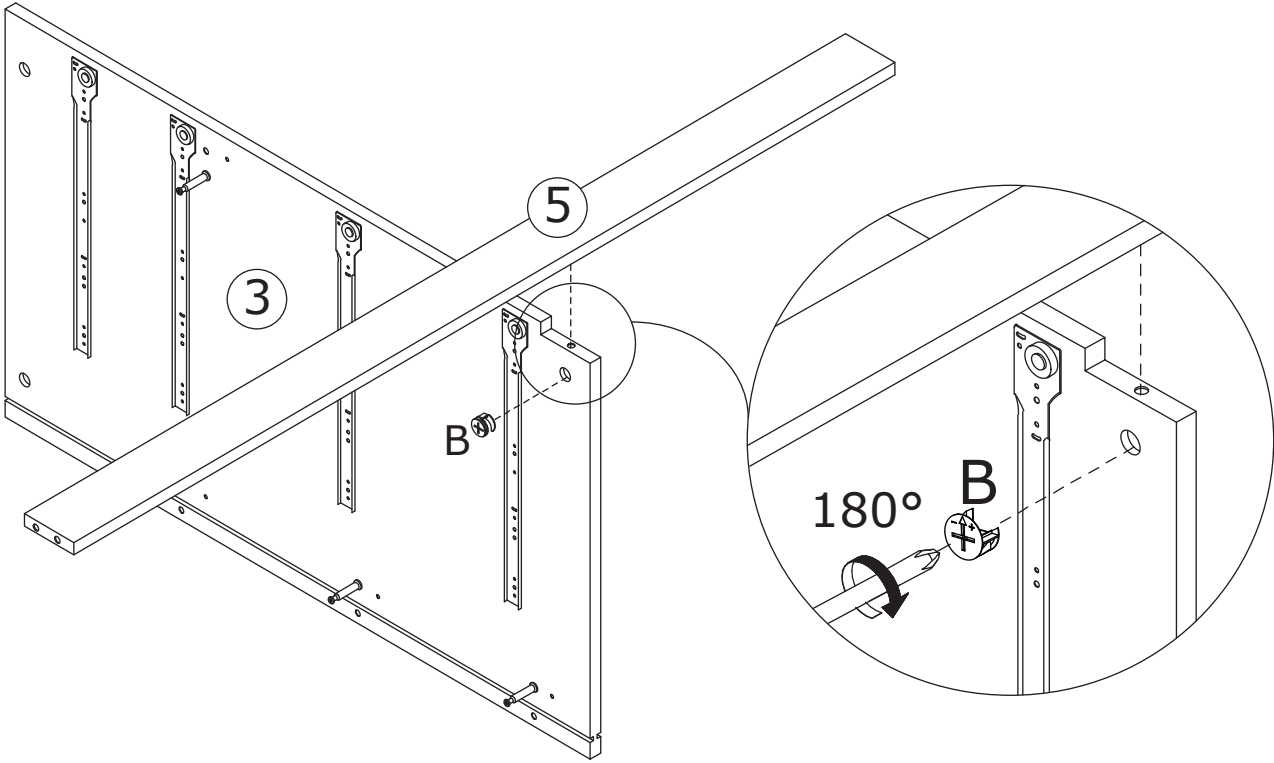
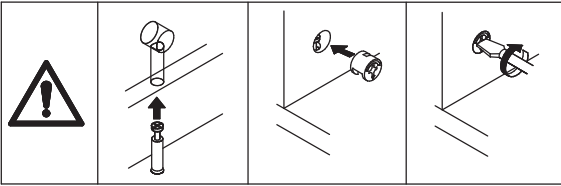
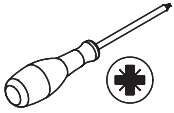

6

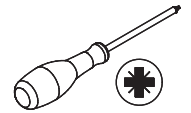
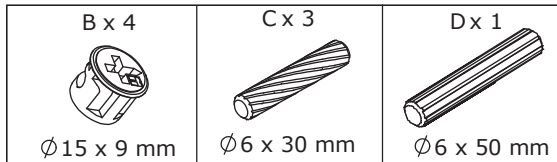

Attach No.6 and No.17 to No.3 plate with short wooden dowel(C); attach No.7 to No.3 plate with long wooden dowel(D), and then turn cam lock(B) in No.7,6,17 plate clockwise to tighten as shown.

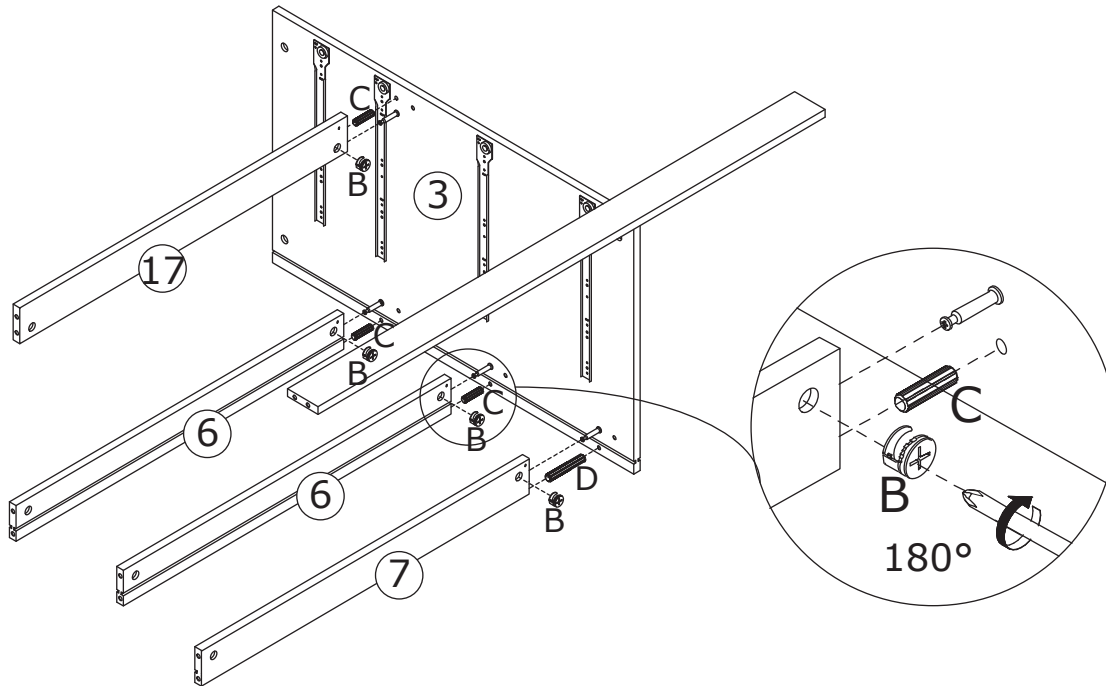
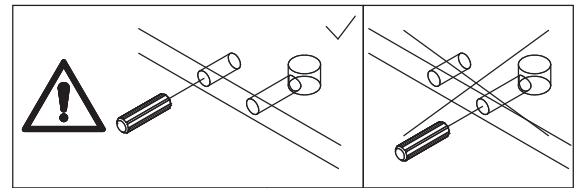

Fixer No.6 et No.17 à la plaque No.3 à l'aide d'une courte cheville en bois(C); fixer No.7 à la plaque No.3 avec une cheville en bois longue (D). No.7 à la plaque No.3 à l'aide d'une longue cheville en bois(D), puis tourner le verrou à came(B) dans la plaque No.7,6,17 dans le sens des aiguilles d'une montre pour serrer comme indiqué.

Befestigen Sie Nr. 6 und Nr. 17 mit einem kurzen Holzdübel (C) an der Platte Nr. 3 ; Nr. 7 anbringen an Nr.3 Platte mit langem Holzdübel (D), und dann die Nockensperre (B) in Nr.7,6,17 drehen Platte im Uhrzeigersinn, um sie wie abgebildet festzuziehen.

7

F x 8  Ø3 x 12 mm	P x 4 	
--	--	--

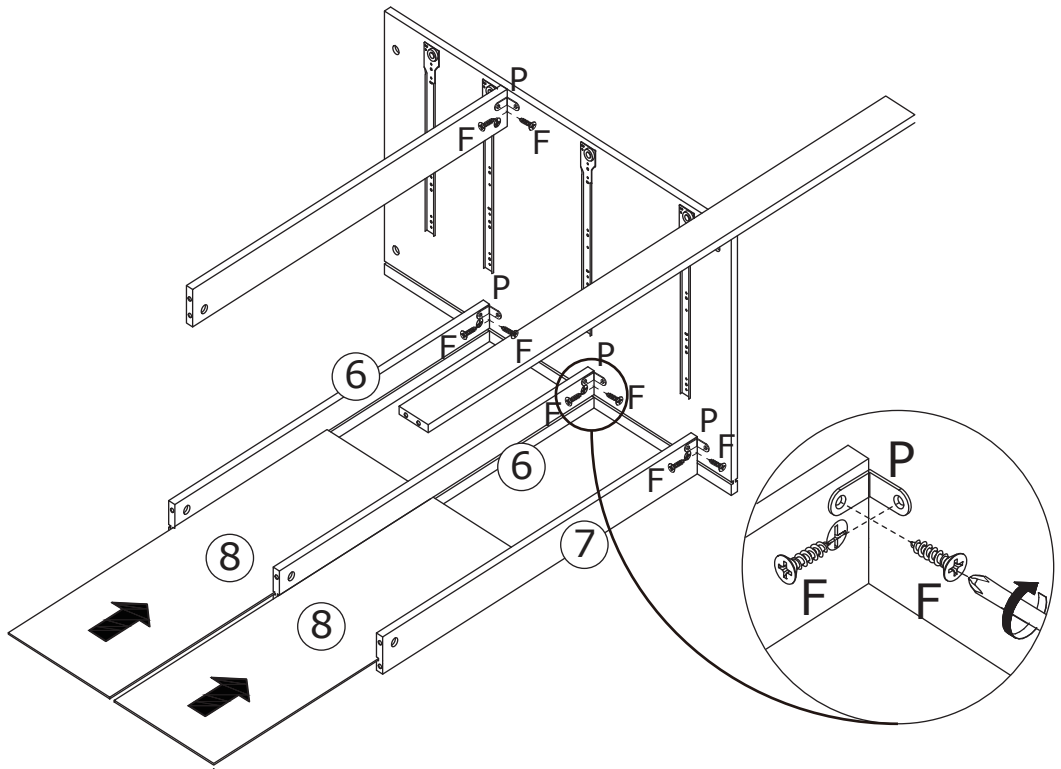

8

B x 5  Ø15 x 9 mm	C x 5  Ø6 x 30 mm	
--	--	---

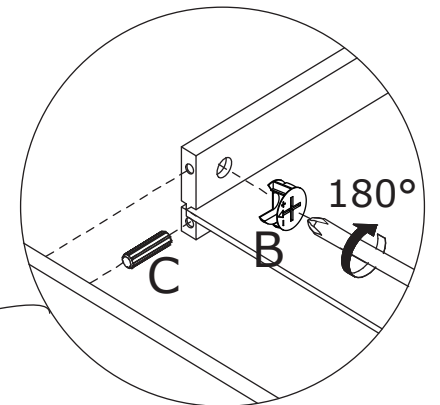
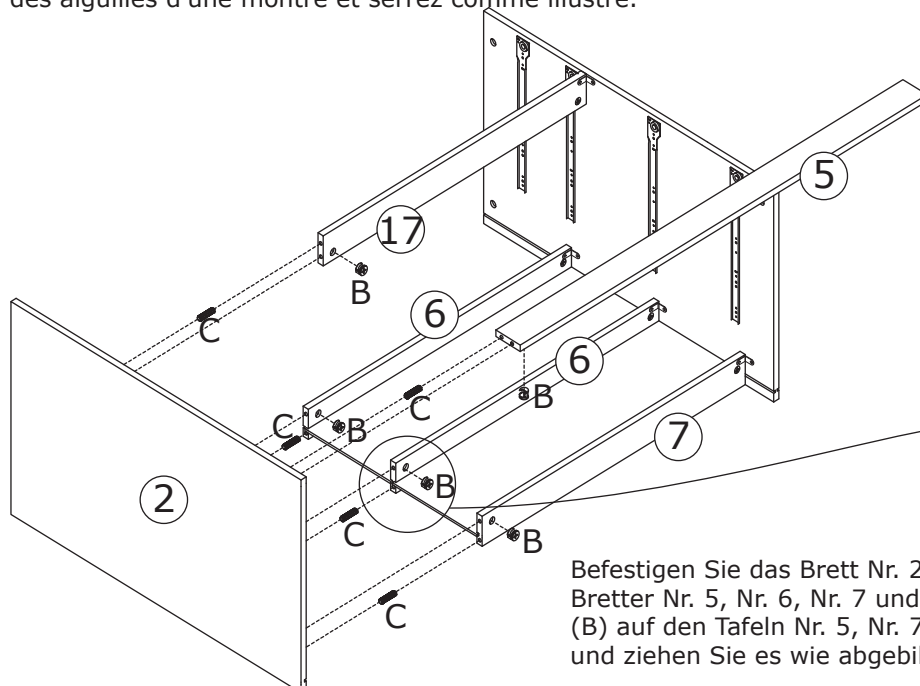
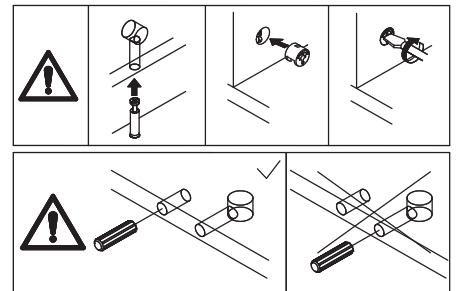

Attach No.2 plate to No.5, No.6, No.7 and No.17 plate with wooden dowel(C) , turn cam lock(B) clockwise in No.5,7,6,17 plate to tighten as shown.

Utilisez une goupille en bois (C) pour fixer la planche n ° 2 aux planches n ° 5, n ° 6, n ° 7 et n ° 17, tournez le verrou à came (B) sur les planches n ° 5, n ° 7, n ° 6 et n ° 17 dans le sens des aiguilles d'une montre et serrez comme illustré.

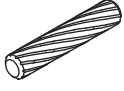

Befestigen Sie das Brett Nr. 2 mit einem Holzstift (C) an der Bretter Nr. 5, Nr. 6, Nr. 7 und Nr. 17, drehen Sie das Nockenschloss (B) auf den Tafeln Nr. 5, Nr. 7, Nr. 6 und Nr. 17 in der Richtung und ziehen Sie es wie abgebildet fest. ♦

9

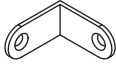
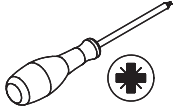
<p>B x 5</p>  <p>Ø15 x 9 mm</p>	<p>C x 4</p>  <p>Ø6 x 30 mm</p>	<p>F x 2</p>  <p>Ø3 x 12 mm</p>	<p>P x 1</p> 	
--	--	--	--	---

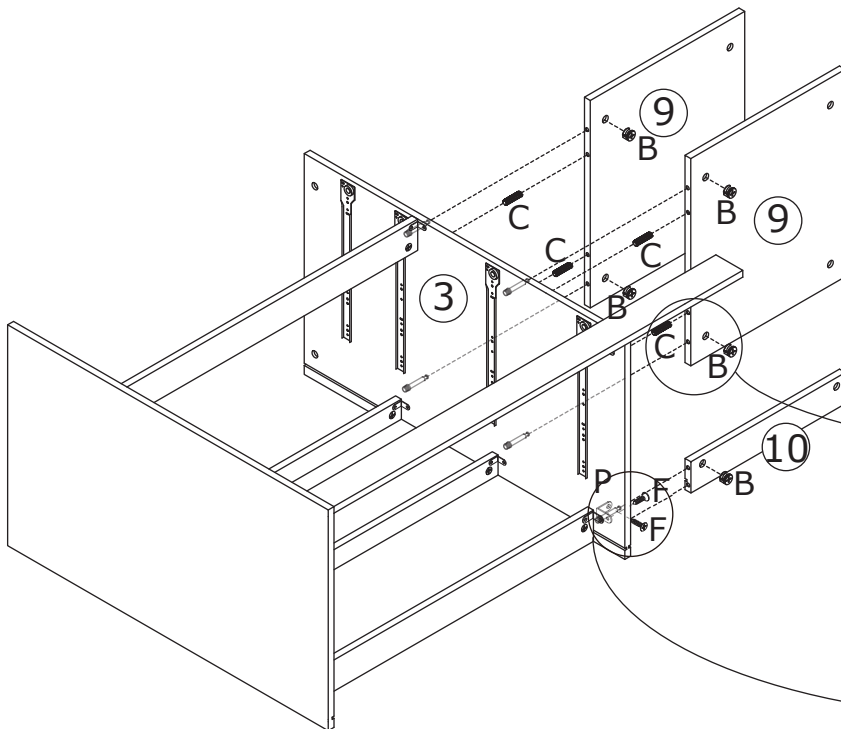
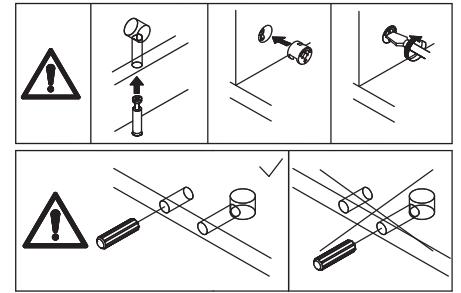

Attach No.9(x2) to No.3 plate with wooden dowel(C), turn cam lock(B) in No.9 plate clockwise to tighten as shown.

Fixez le n ° 9 (x2) sur la plaque n ° 3 avec une goupille en bois (C), tournez le verrou à came (B) sur la plaque n ° 9 dans le sens des aiguilles d'une montre et serrez-le comme indiqué sur la figure.

Befestigen Sie Nr. 9 (x2) an der Platte Nr. 3 mit Holzdübel (C), Drehnockenschloss (B) in Nr.9 Platte im Uhrzeigersinn z um Festziehen gezeigt.

Connect No.10 plate with the assembled long wooden dowel(D), turn cam lock(B) in No.10 plate clockwise to tighten as shown.

Connectez la plaque n ° 10 à la longue goupille en bois assemblée (D), tournez le verrou à came (B) dans la plaque n ° 10 dans le sens des aiguilles d'une montre et serrez-le comme indiqué sur la figure.

Verbinden Sie die Platte Nr. 10 mit dem montierten langen Holzdübel(D), drehen Nockenverschluss(B) in Platte Nr.10 im Uhrzeigersinn, um sie wie gewünscht zu festziehen.

10

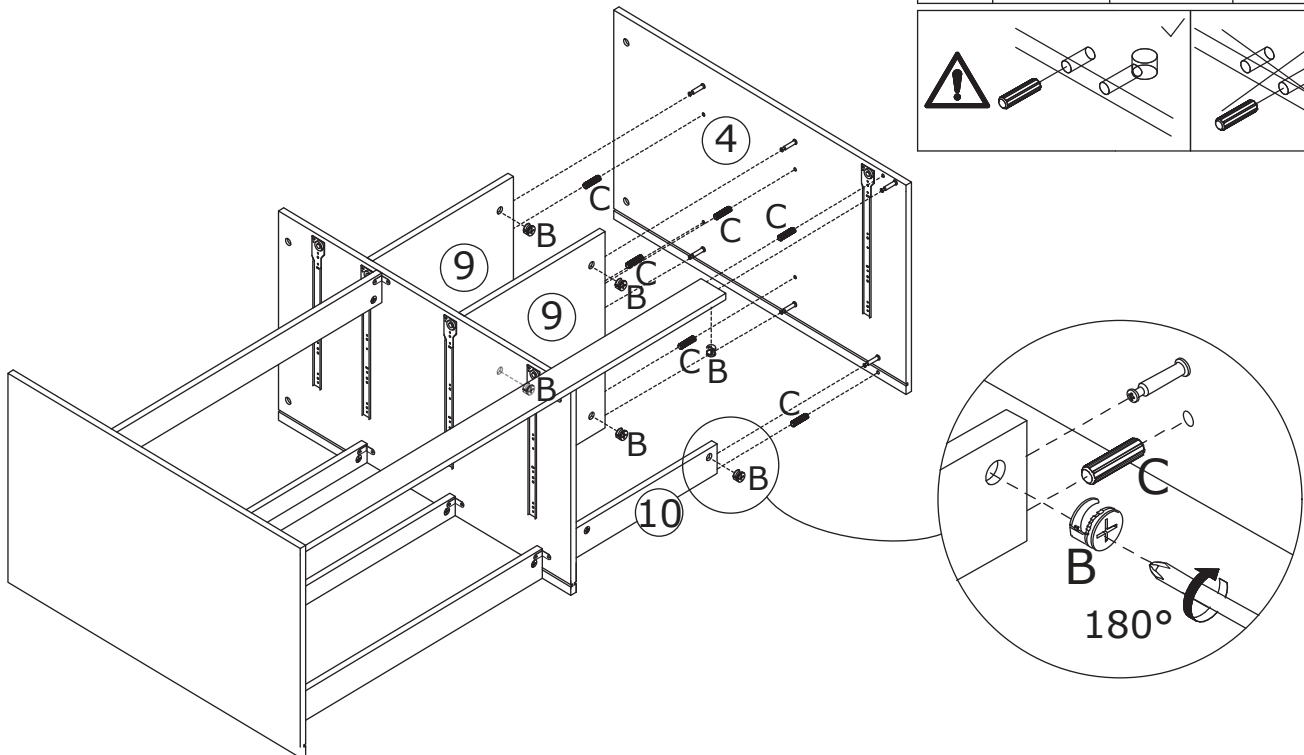
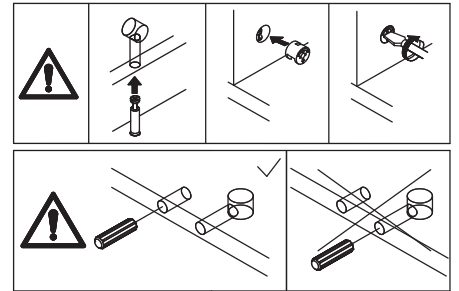

Attach No.4 plate to No.9 and No.10 plate with wooden dowel(C), turn cam lock(B) clockwise in No.9,10 plate to tighten as shown.

Fixer la plaque No.4 aux plaques No.9 et No.10 à l'aide d'une cheville en bois(C). avec une cheville en bois (C), tourner le verrou à came (B) dans le sens des aiguilles d'une montre dans la plaque No.9,10 pour serrer comme indiqué.
No.9,10 dans le sens des aiguilles d'une montre pour serrer comme indiqué.

Befestigen Sie die Platte Nr. 4 an der Platte Nr. 9 und Nr. 10 mit Holzdübel (C), Nockenschloss (B) im Uhrzeigersinn drehen Nr. 9,10 Platte zum Festziehen wie abgebildet.

11

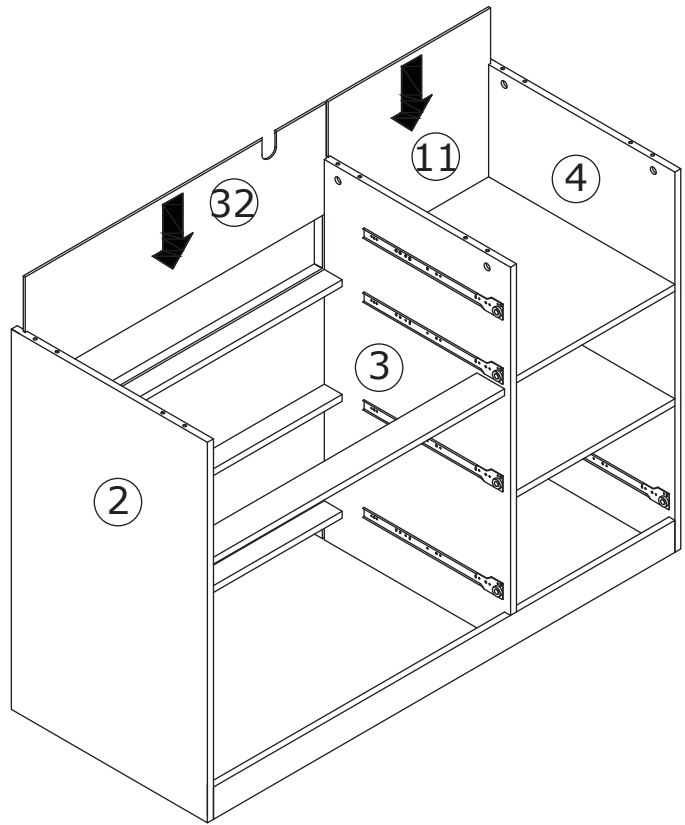

12

<p>B x 6</p>  <p>Ø15 x 9 mm</p>	<p>C x 6</p>  <p>Ø6 x 30 mm</p>	
--	--	---

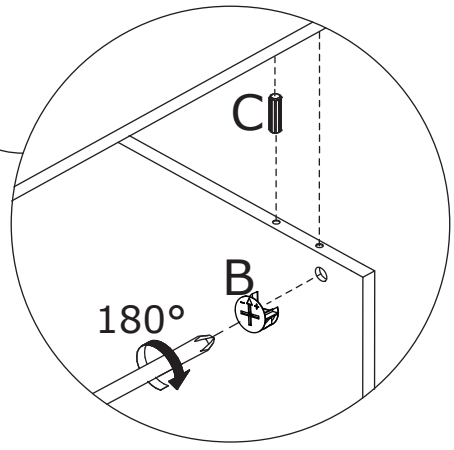
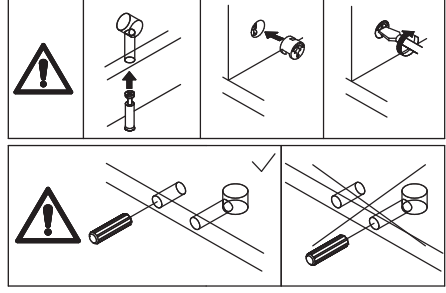
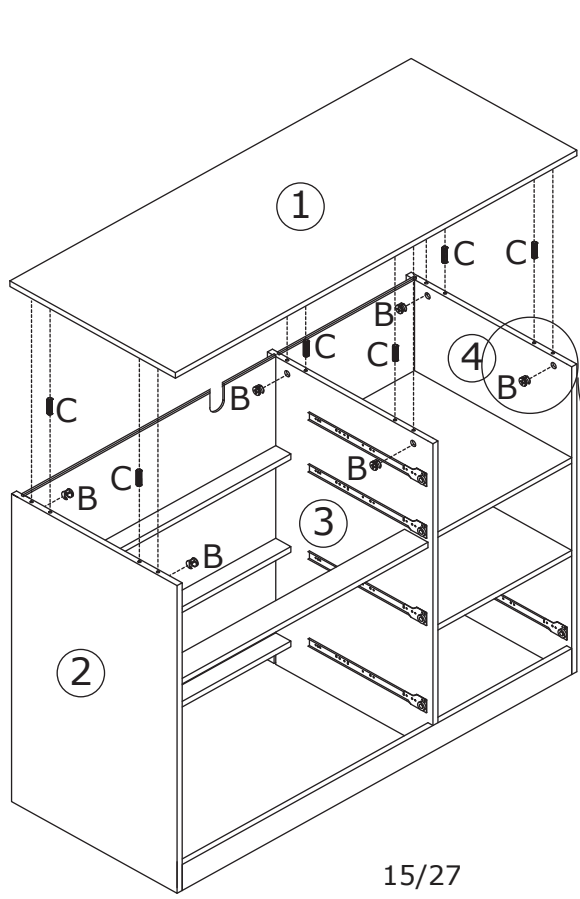

13

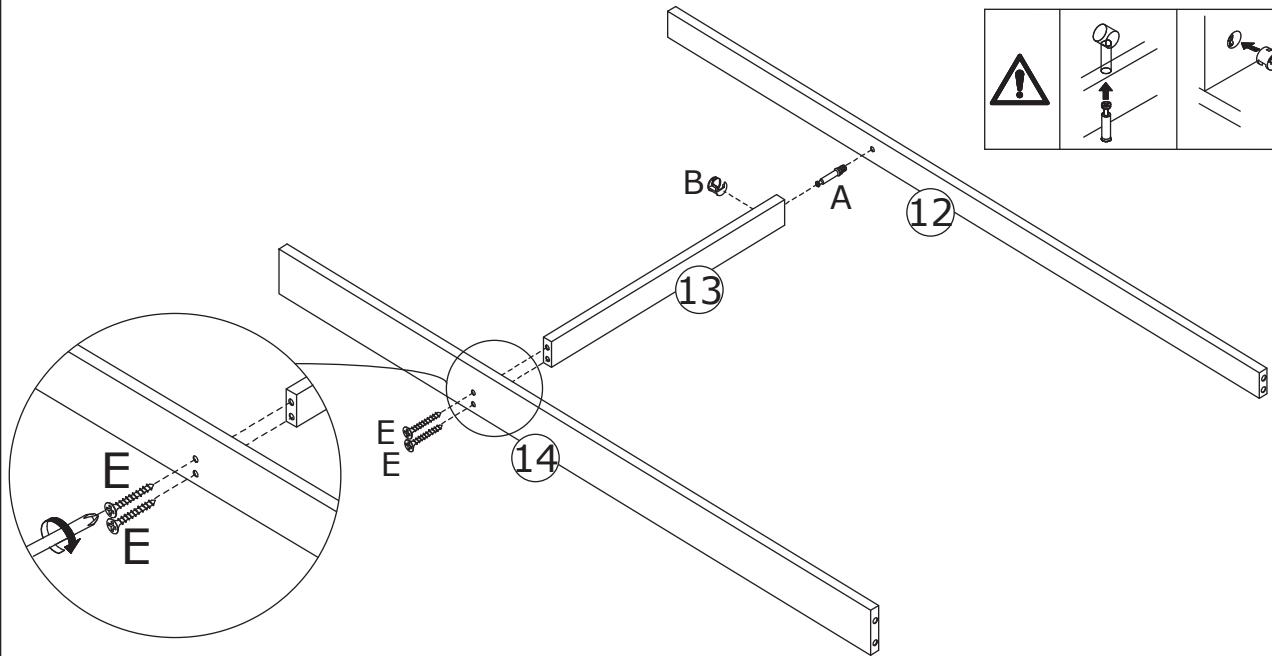
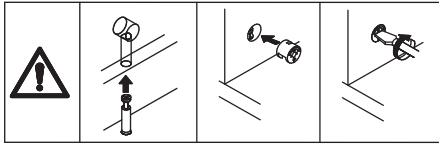
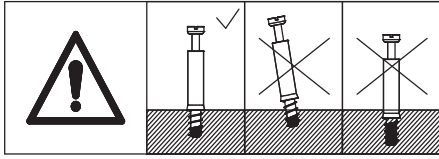
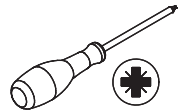
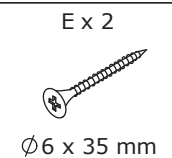
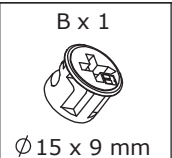
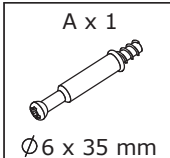

14

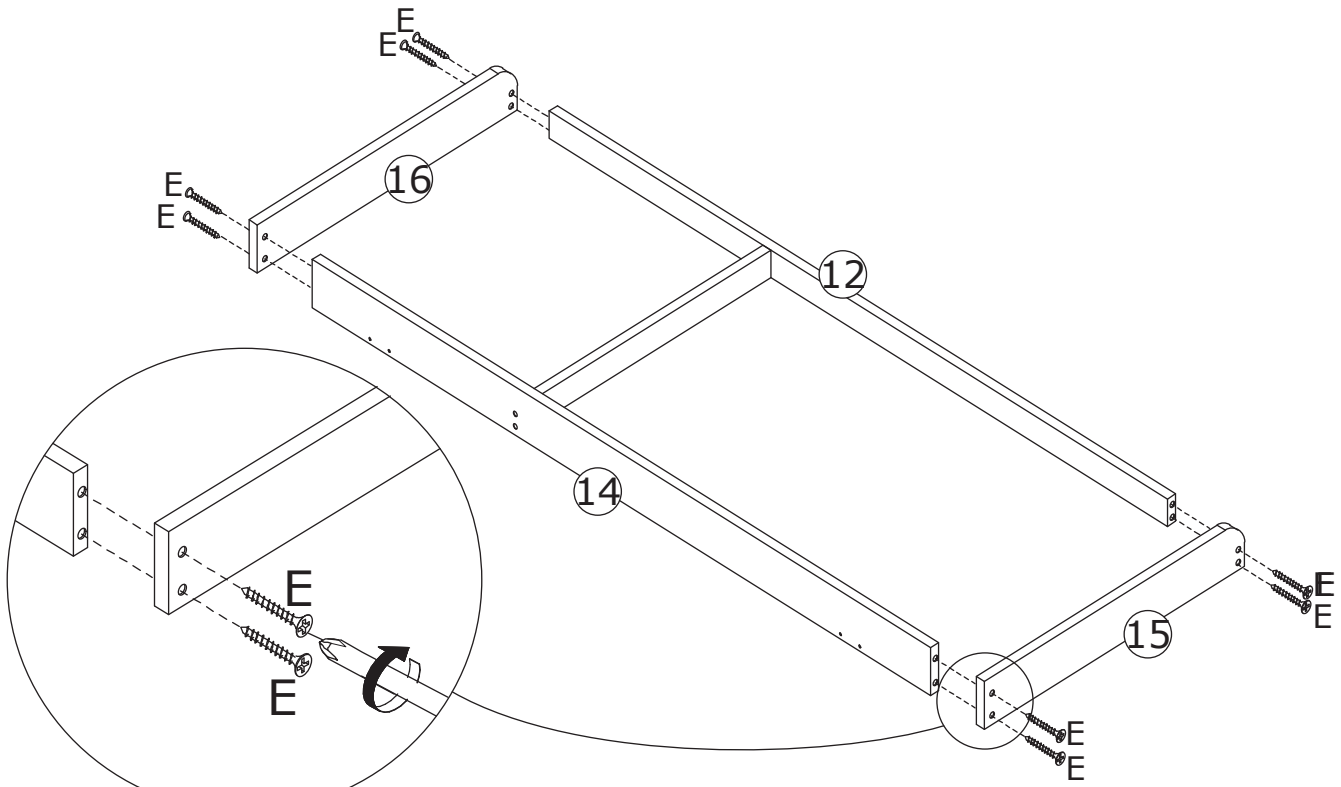
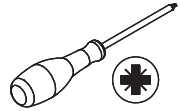
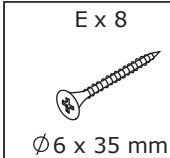

15

H x 8



Ø3 x 14 mm

I x 2

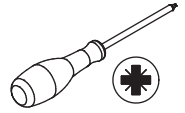
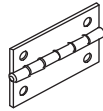

Place the frame to the top,
and use part(I) to fix with
back plate together using
screw(H) as shown.

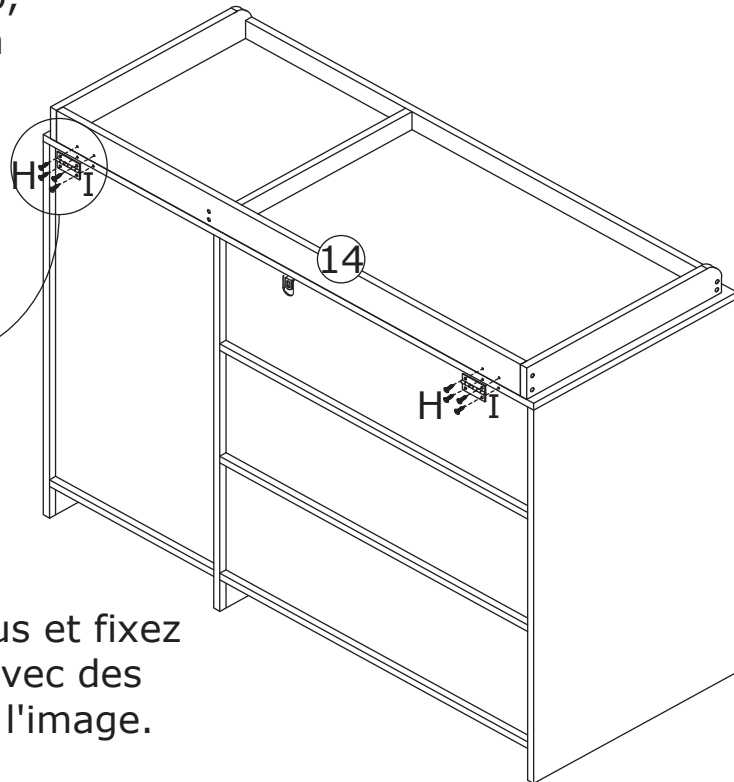
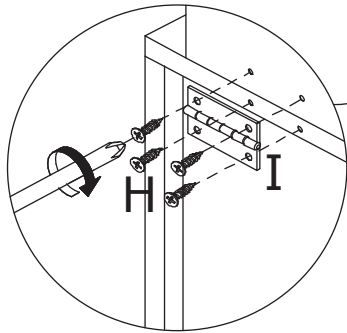

Placez le cadre sur le dessus et fixez
la plaque arrière avec (I) avec des
vis (H) comme indiqué sur l'image.

Setzen Sie den Rahmen nach oben,
und verwenden Sie Teil (I), um mit
Rückwand zusammen mit
Schraube(H) wie gezeigt.

16

J x 16



Ø3 x 16 mm

K x 16

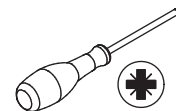
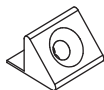

Reinforce back plate using part(K) with screw(J) as shown.

Consolider la plaque arrière avec la pièce (K) avec vis (J) comme illustré.

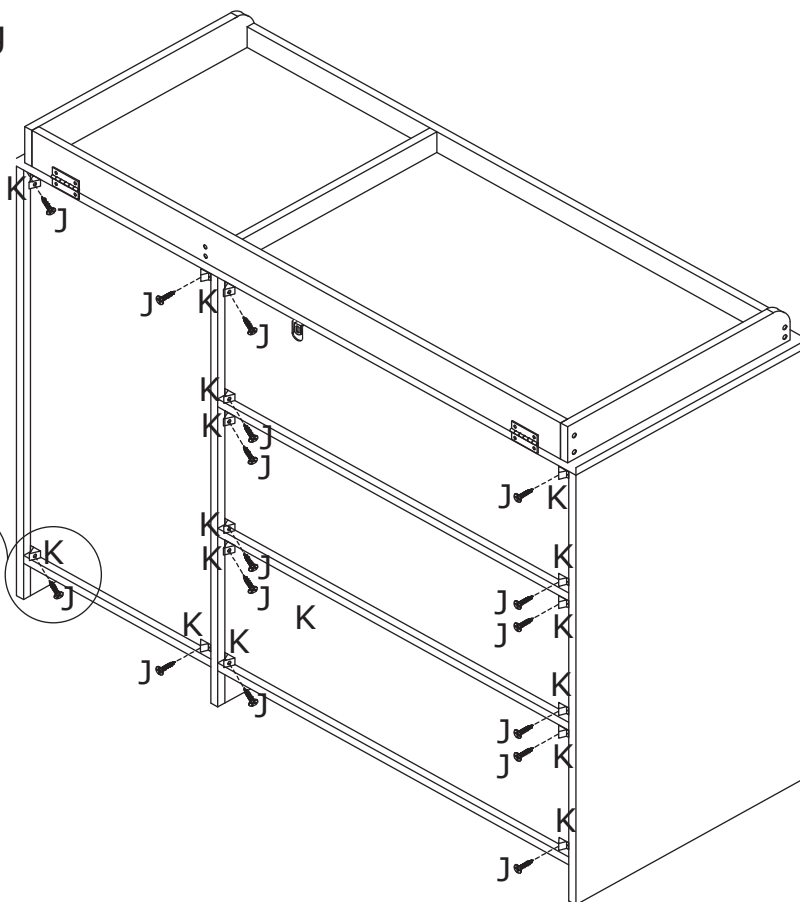
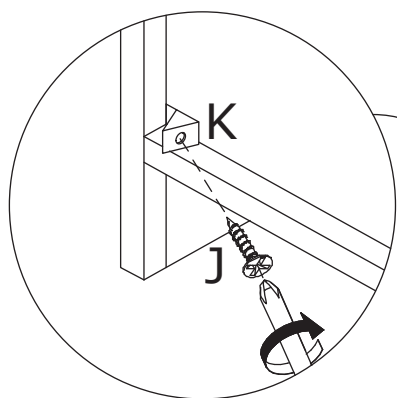

Verstärken Sie die Rückplatte mit Teil(K) mit Schraube(J) als gezeigt.

17

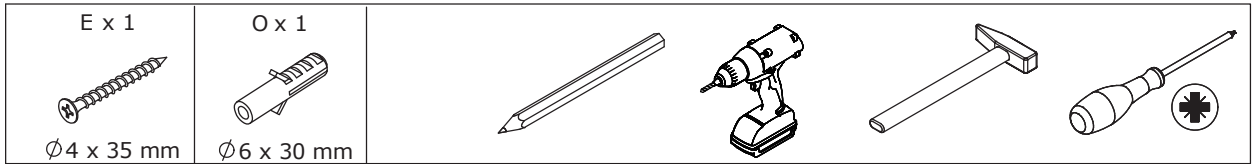



Install anti-tipping device
as you like.

Installer le dispositif anti-basculement
comme vous le souhaitez.

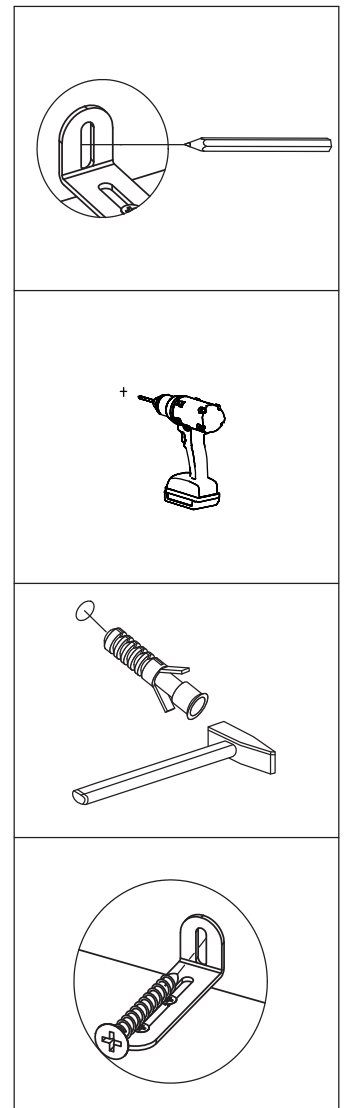
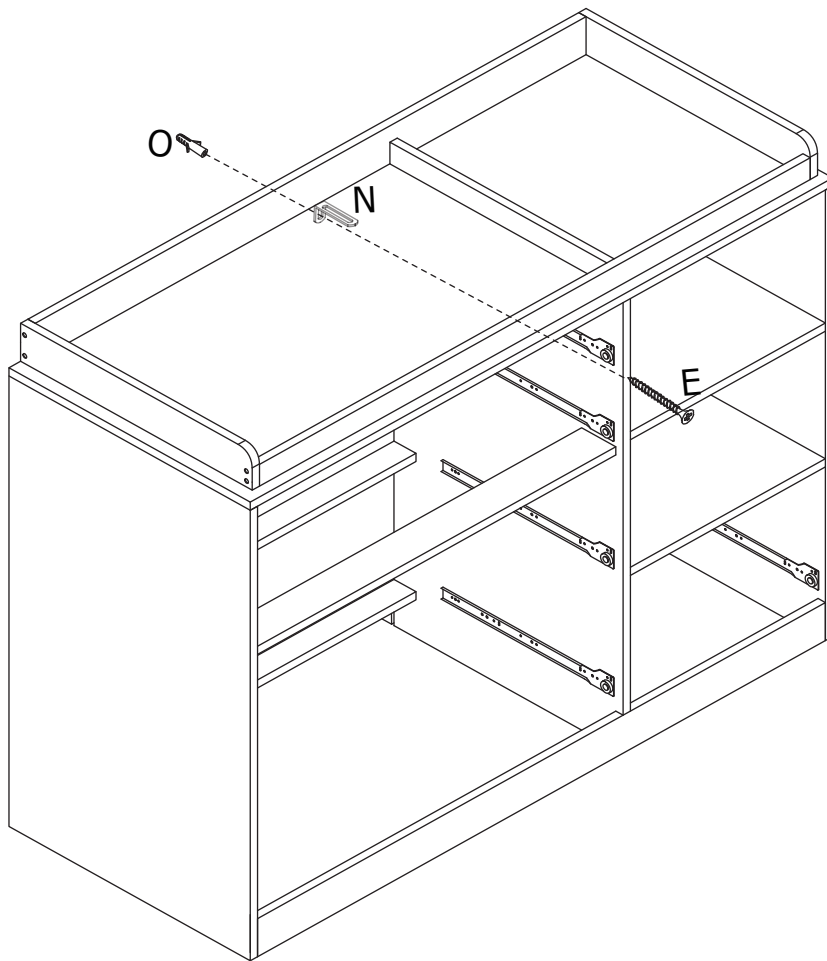
Installieren Sie die Kippschutzvorrichtung
wie Sie möchten.





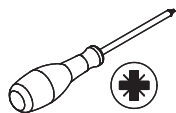

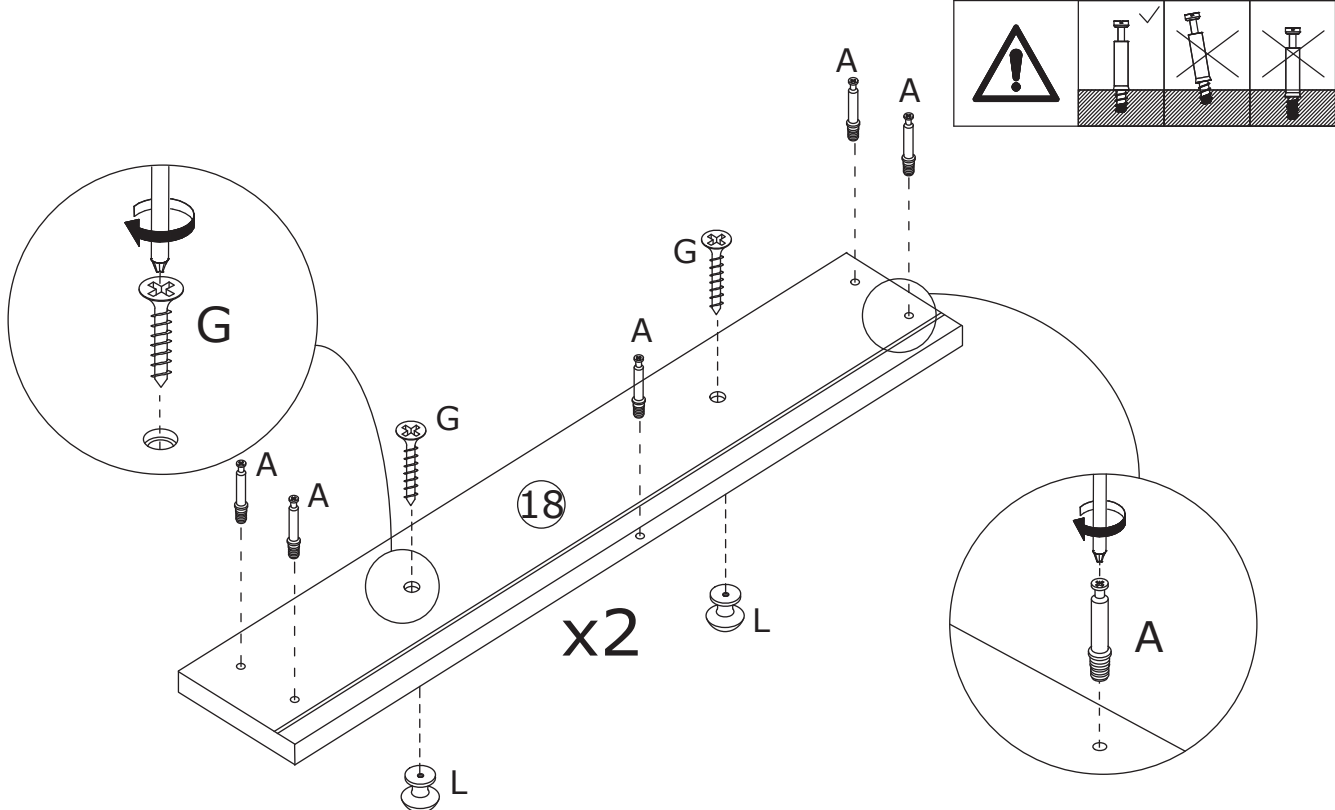
18

<p>A x 10  Ø6 x 35 mm</p>	<p>G x 4  Ø4 x 25 mm</p>	<p>L x 4 </p>	
--	---	---	---



19

<p>F x 8  Ø3 x 12 mm</p>	<p>DR x 2 </p>	<p>DL x 2 </p>	
---	--	--	---

Fix runner(DL) and (DR) to No.19 and No.20 plate respectively with screw(F) as shown.

Fixer les patins (DL) et (DR) à la plaque No.19 et No.20 respectivement à l'aide de vis(F) comme indiqué.

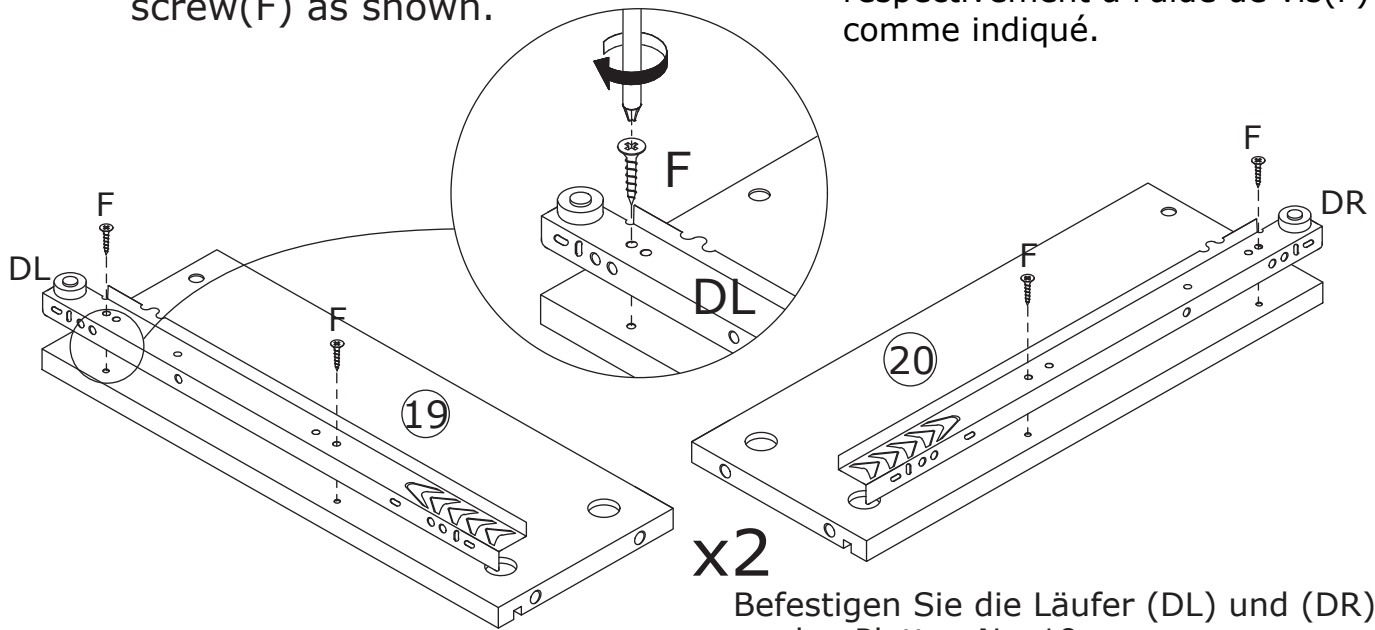

x2
 Befestigen Sie die Läufer (DL) und (DR) an den Platten Nr. 19 bzw. Nr.20 mit Schraube(F) wie gezeigt.

20

E x 10
Ø4 x 35 mm

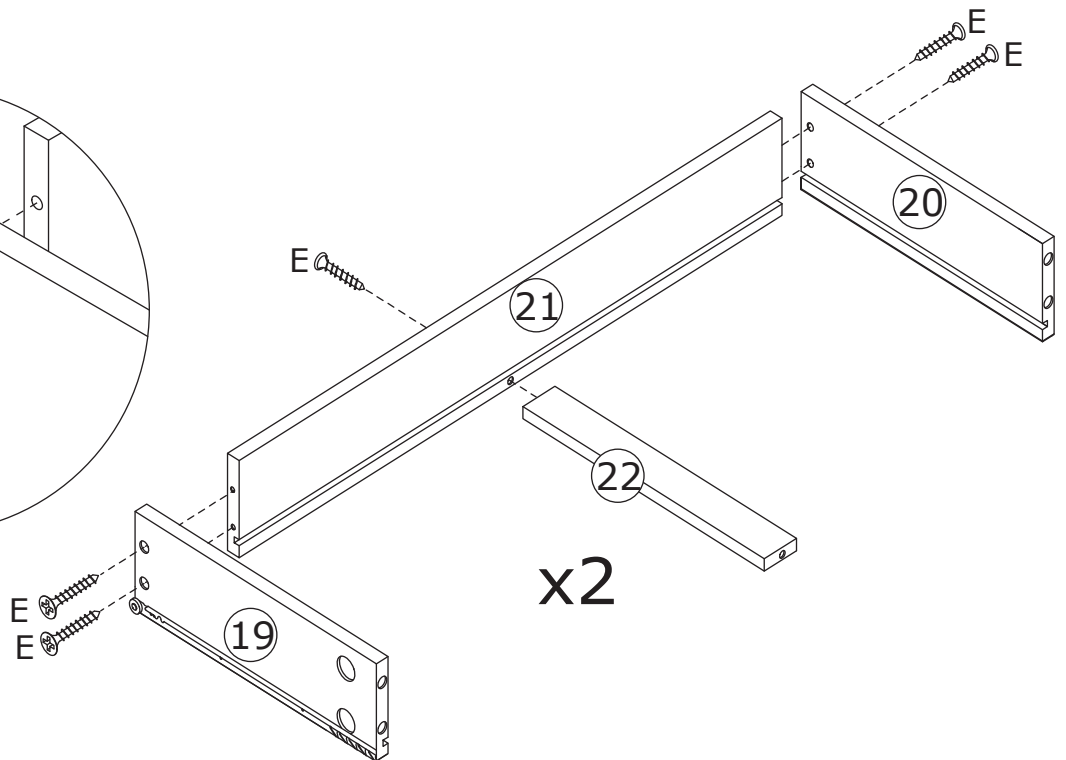
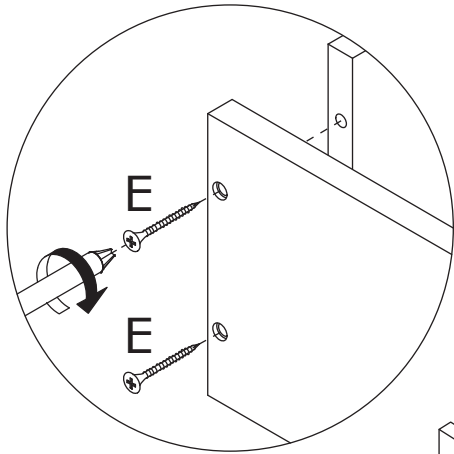
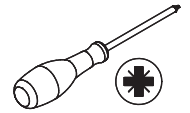

21

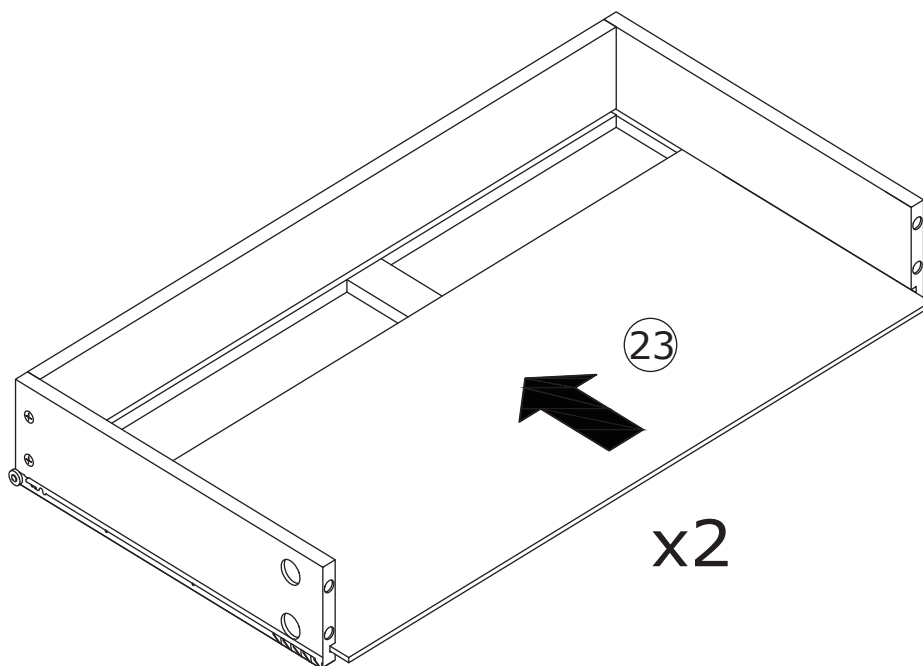

22

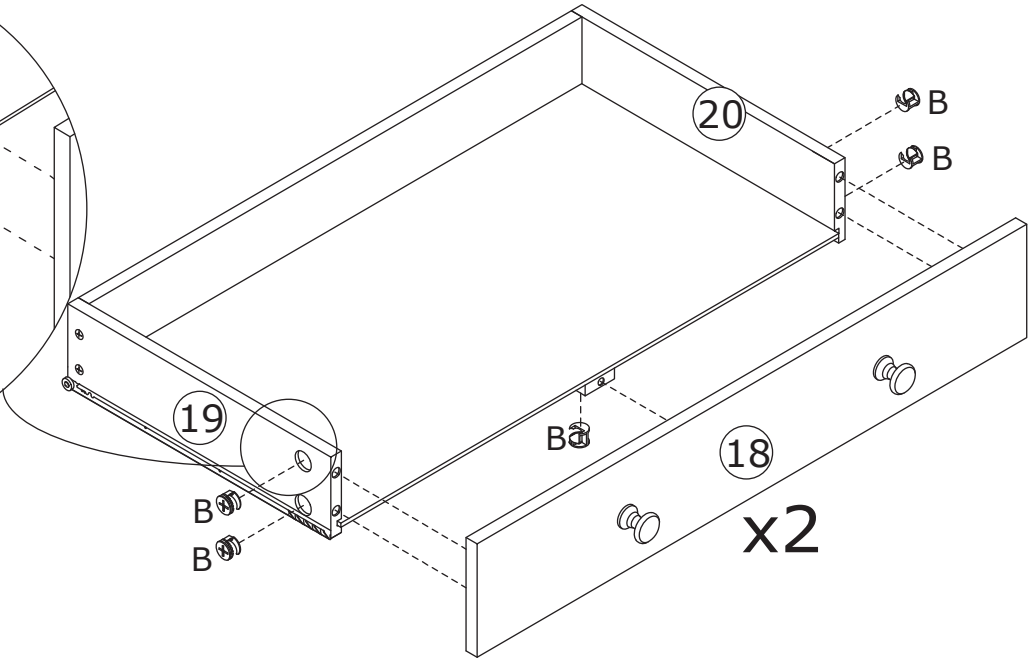
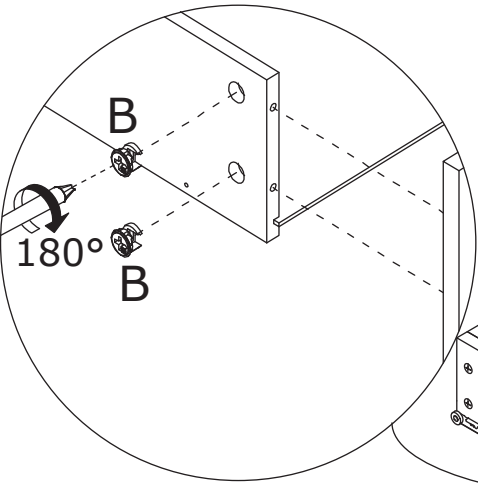
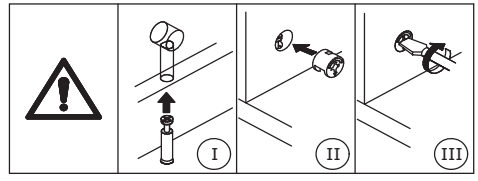
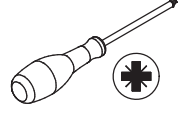
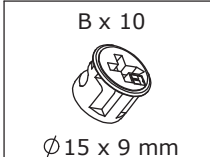

23

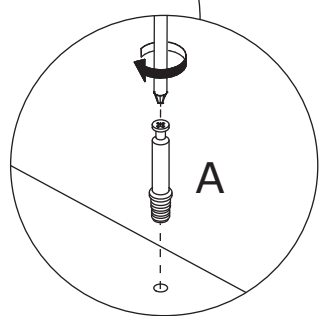
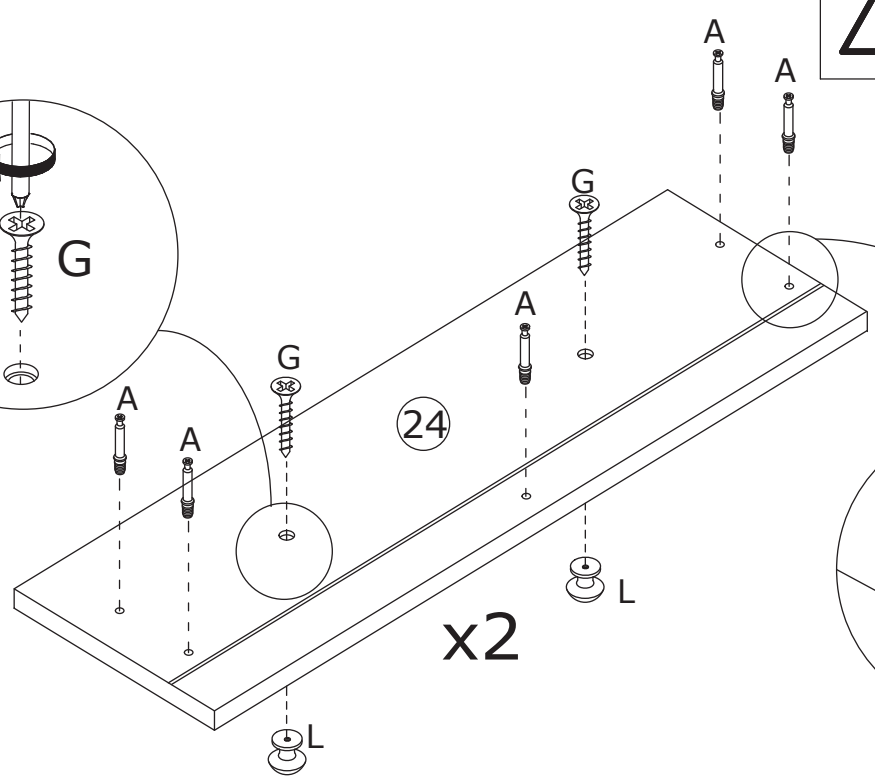
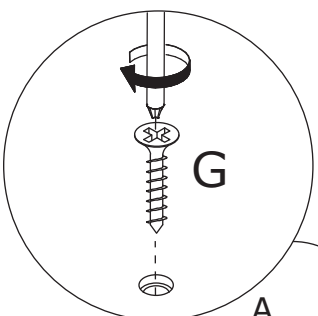
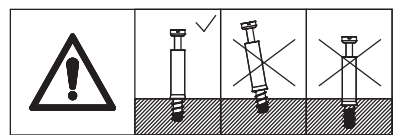
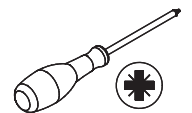
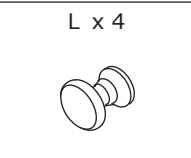
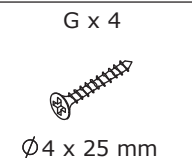
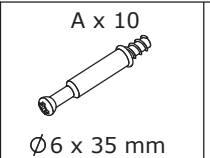

24

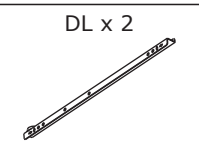
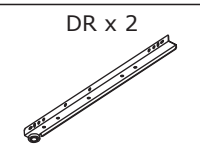
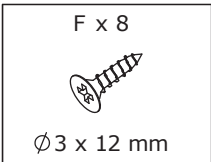

Fix runner(DL) and (DR) to No.25 and No.26 plate respectively with screw(F) as shown.

Fixer le coureur (DL) et (DR) aux plaques No.25 et No.26 respectivement avec lesà l'aide de la vis(F) comme indiqué.

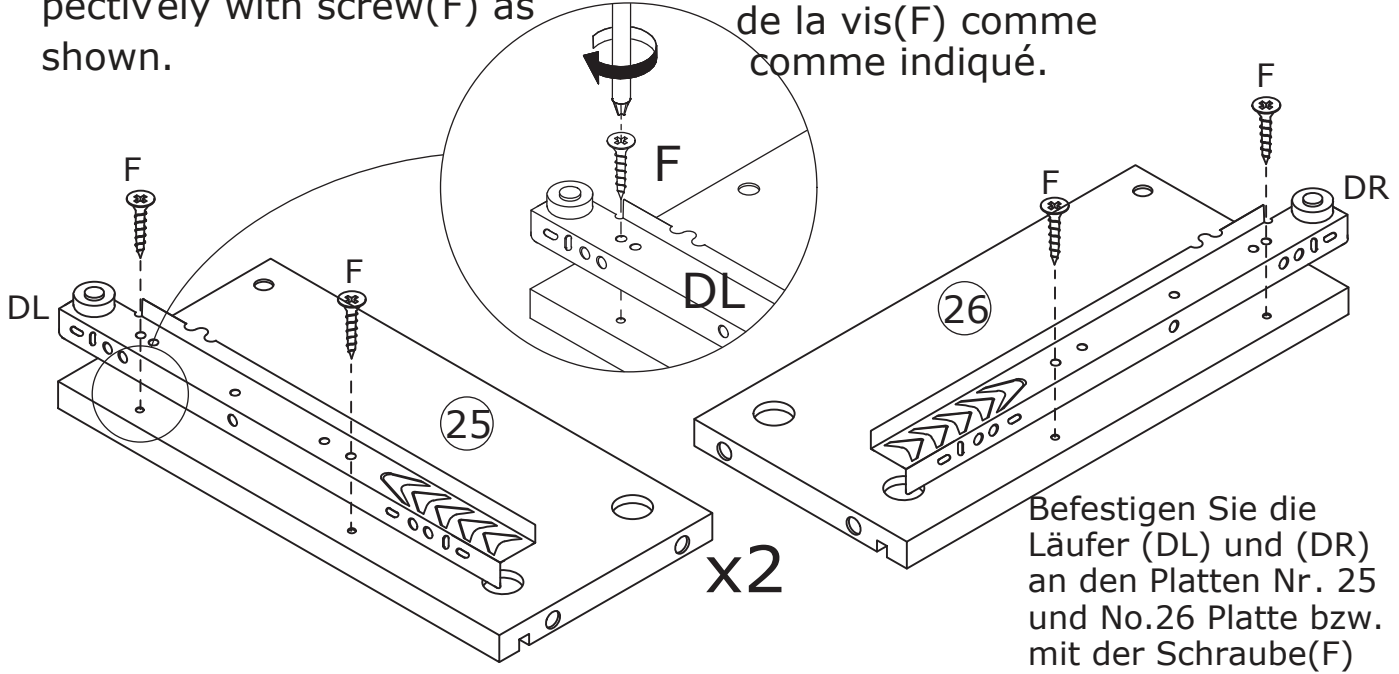

Befestigen Sie die Läufer (DL) und (DR) an den Platten Nr. 25 und No.26 Platte bzw. mit der Schraube(F) wie dargestellt.

25

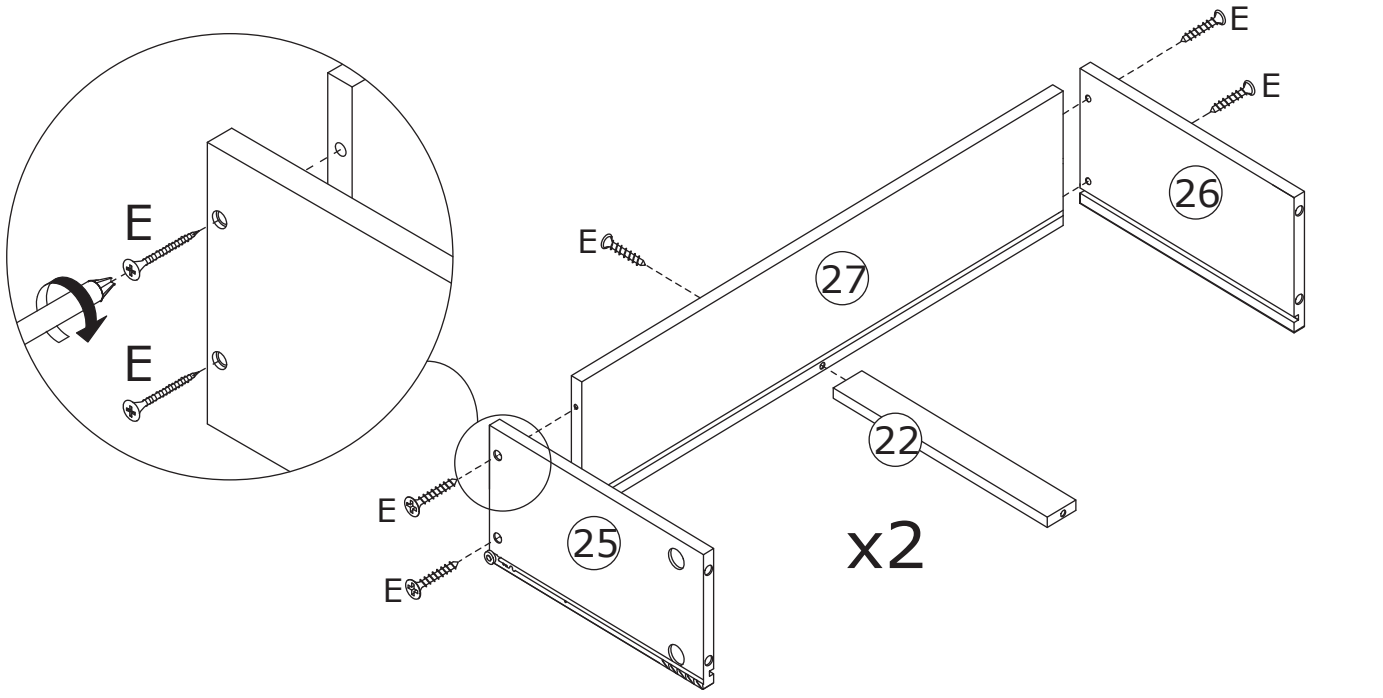
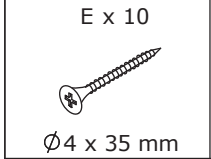

26

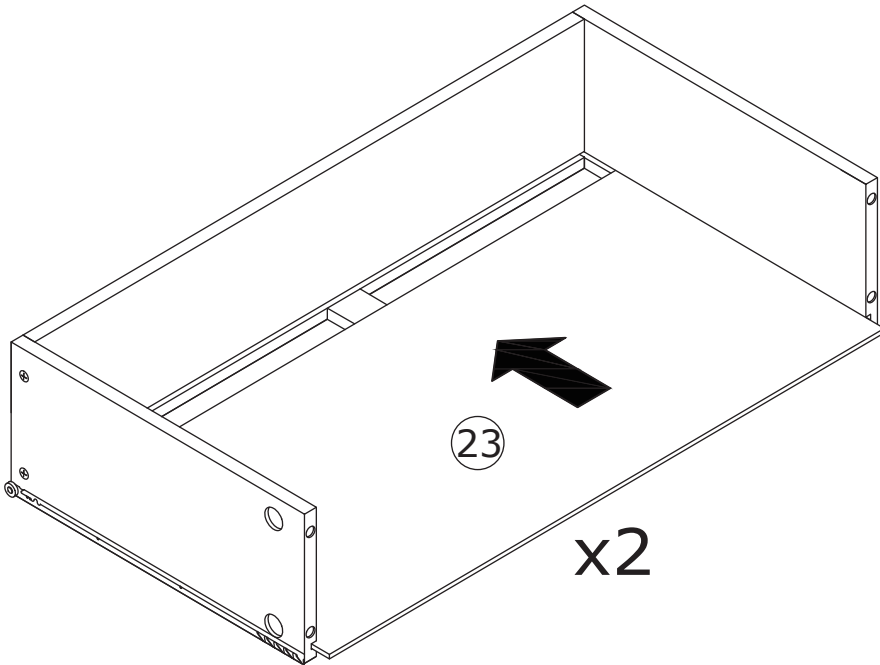
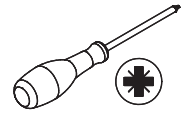

27



B x 10

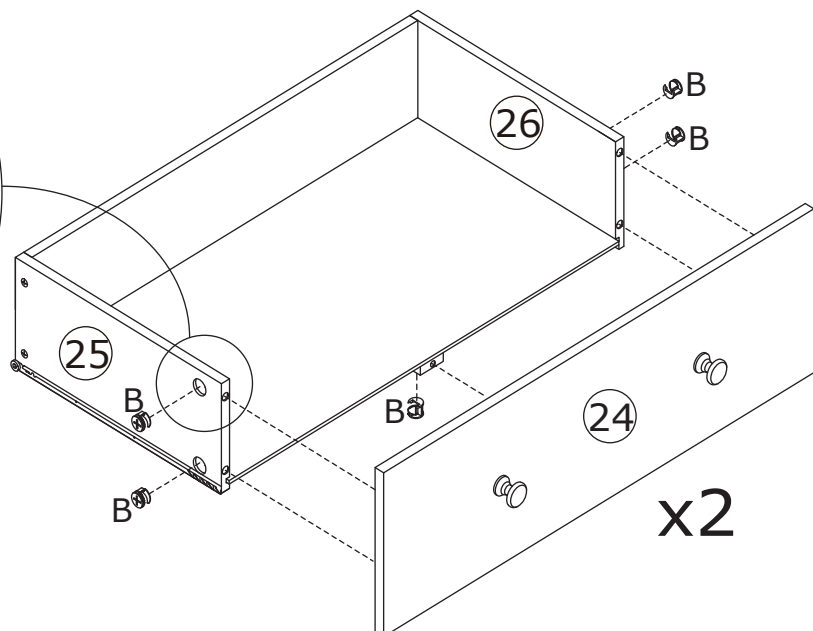
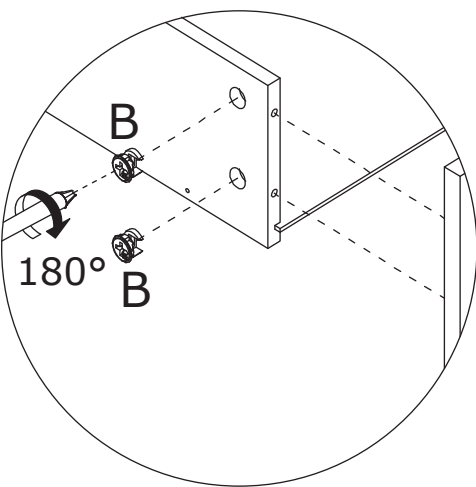
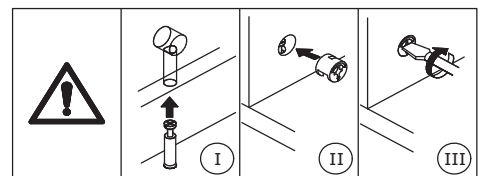
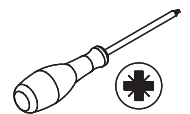

Ø15 x 9 mm



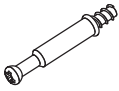

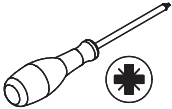
28

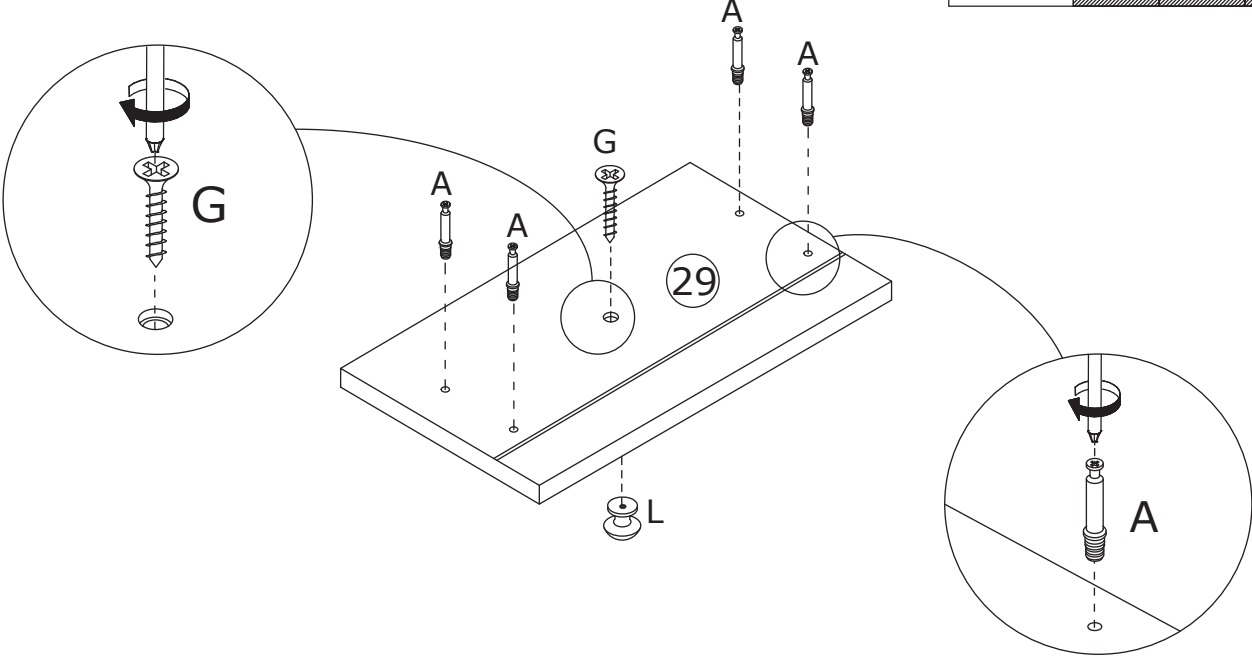
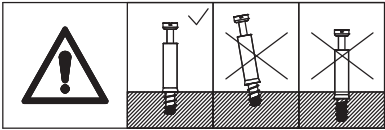
<p>A x 4</p>  <p>Ø6 x 35 mm</p>	<p>G x 1</p>  <p>Ø4 x 25 mm</p>	<p>L x 1</p> 	
--	--	--	---

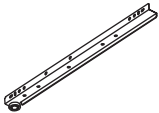

29

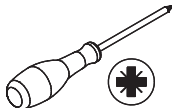
<p>F x 4</p>  <p>Ø3 x 12 mm</p>	<p>DR x 1</p> 	<p>DL x 1</p> 	
--	---	---	---

Fix runner(DL) and (DR) to No.25 and No.26 plate respectively with screw(F) as shown.

Fixer les glissières (DL) et (DR) aux plaques No.25 et No.26 respectivement avec la vis(F) comme indiqué.

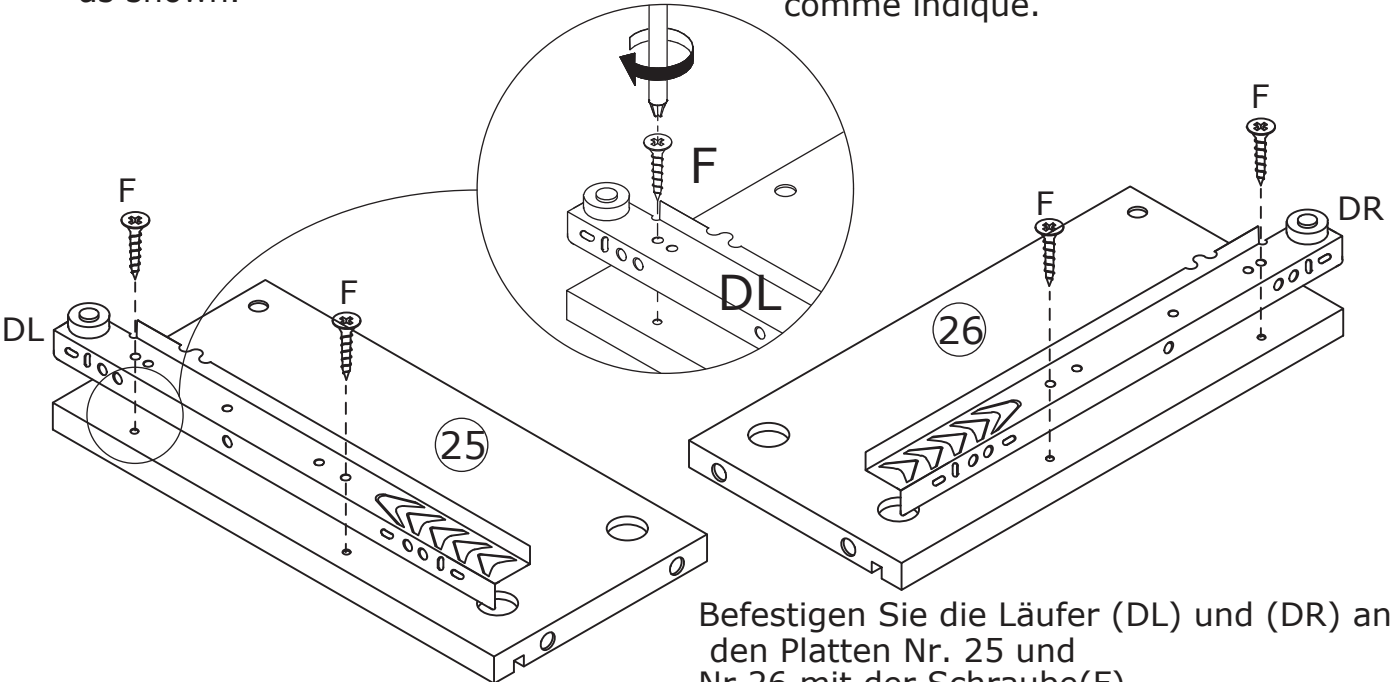

Befestigen Sie die Läufer (DL) und (DR) an den Platten Nr. 25 und Nr.26 mit der Schraube(F) wie gezeigt.

30

E x 4
Ø4 x 35 mm

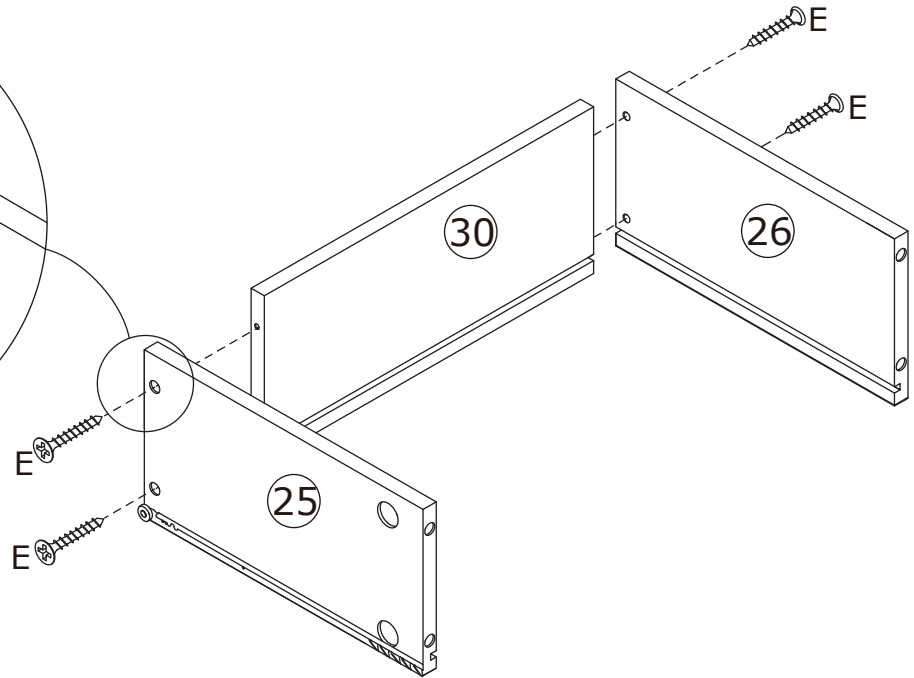
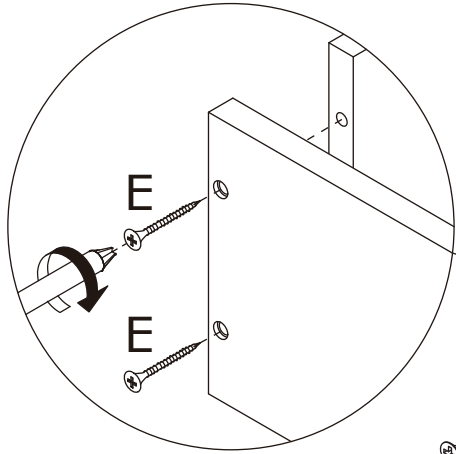
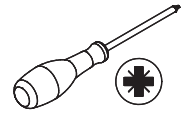

31

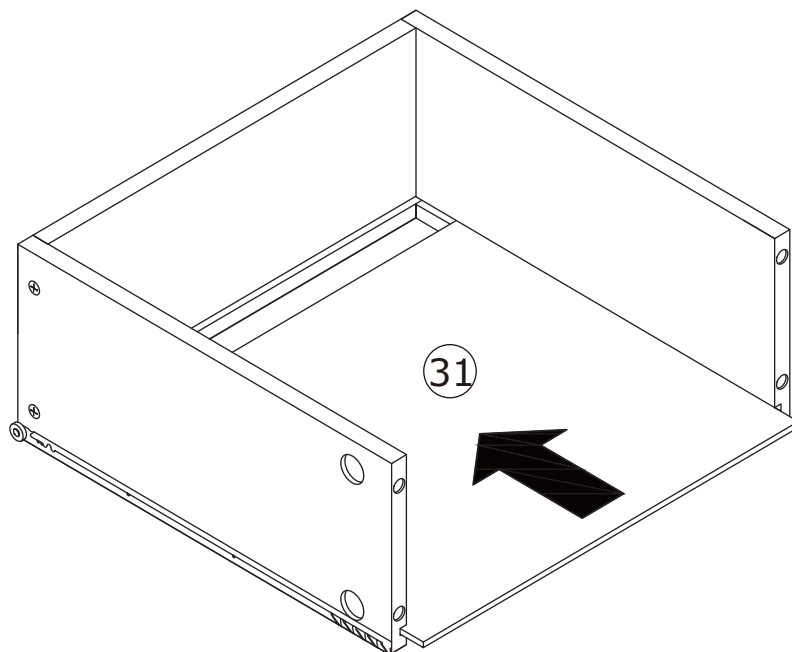

32

B x 4
Ø15 x 9 mm

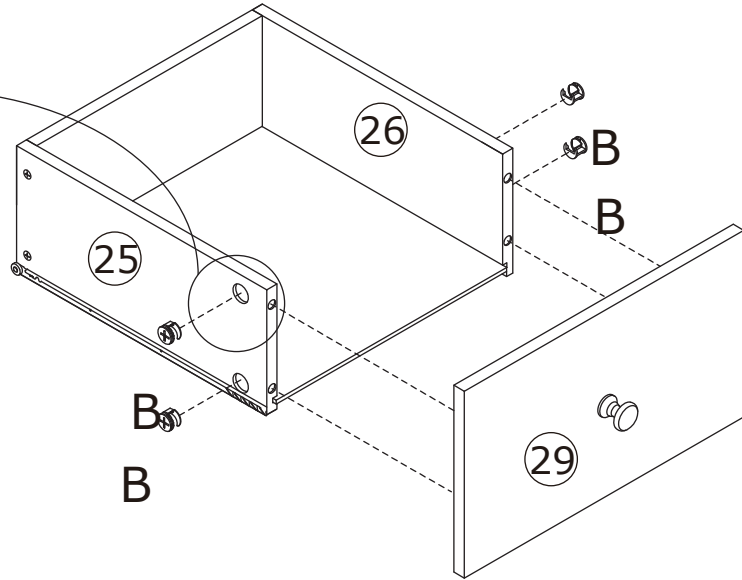
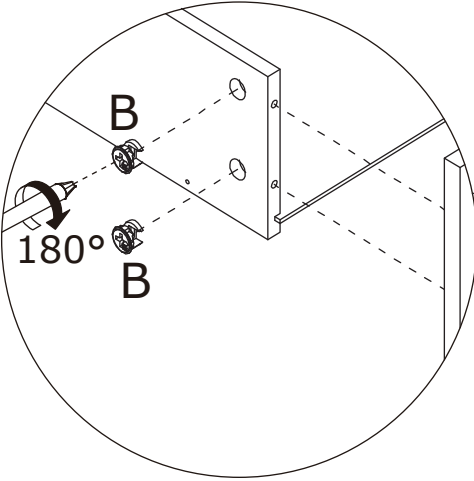
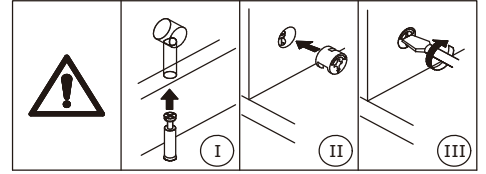
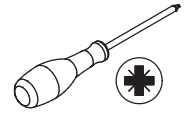

33

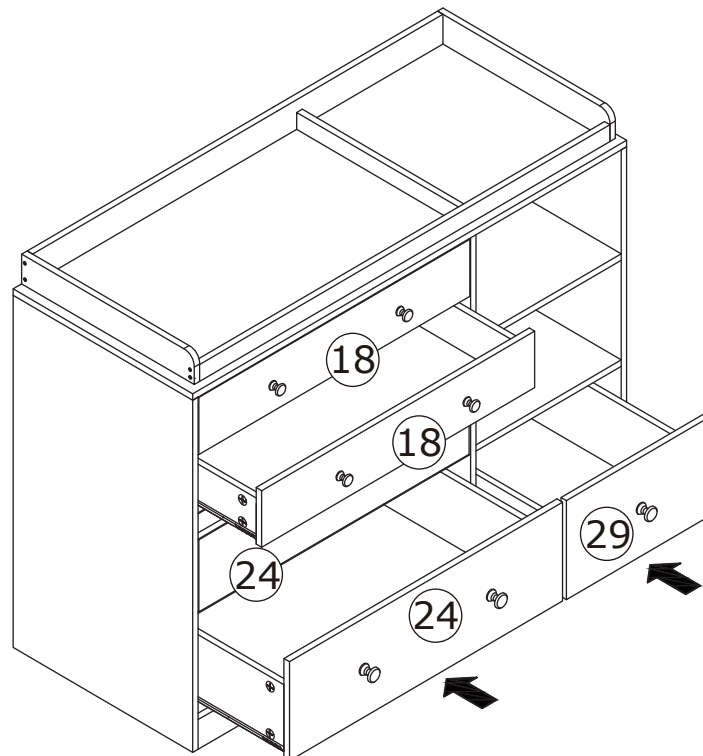

WARRANTY

WARRANTY CLAIMS

- There is a 30-day warranty for broken furniture or any other problems that do not work properly. The warranty will start from the date of purchase which must be verified by proof of purchase.
- Before making a claim, we may be able to answer your query, simply call us. Please leave your purchase order number, along with some details of the problem, if you want a replacement part. We will arrange within 48 hours. If there is out of stock, we will reply with a shipping date.
- The product must be used in accordance with the instructions provided. For health reasons.
- For other reasons, if the furniture needs to be returned, it must be cleaned and dried and operated within 30 days of receipt.

Type of Warranty Claim

- Failure to follow the furniture instructions will invalidate the warranty. Attention please.
- Does not include damage during installation, but includes damage during transportation.

Scope of responsibility

- Shall not bear any responsibility for misuse or user damage and / or loss of parts during the installation of furniture.
- After using, the damage and scratches of the furniture are not covered by the warranty.

The Warranty Relates to All Bought in The Us and Covers The Following Areas

- Sheet parts: 1 month from the date of purchase.
- Electrical parts: 1 month from the date of purchase.

GARANTIE

RÉCLAMATIONS DE GARANTIE

Il existe une garantie de 30 jours pour les meubles cassés ou tout autre problème qui ne fonctionne pas correctement. La garantie commencera à partir de la date d'achat qui doit être vérifiée par une preuve d'achat.

Avant de faire une réclamation, nous pourrions peut-être répondre à votre demande, il vous suffit de nous appeler. Veuillez laisser votre numéro de bon de commande, ainsi que quelques détails sur le problème, si vous voulez une pièce de rechange. Nous organiserons dans les 48 heures. En cas de rupture de stock, nous vous répondrons avec une date d'expédition.

Le produit doit être utilisé conformément aux instructions fournies. Pour des raisons de santé.

Pour d'autres raisons, si les meubles doivent être retournés, ils doivent être nettoyés et séchés et utilisés dans les 30 jours suivant leur réception.

Type de demande de garantie

Le non-respect des instructions du meuble annulera la garantie. Attention, s'il vous plaît. N'inclut pas les dommages pendant l'installation, mais inclut les dommages pendant le transport.

Portée de la responsabilité

N'assume aucune responsabilité en cas de mauvaise utilisation ou de dommages causés par l'utilisateur et / ou de perte de pièces lors de l'installation du meuble.

Après utilisation, les dommages et rayures du meuble ne sont pas couverts par la garantie.

La garantie s'applique à tous les produits achetés aux États-Unis, dans tous les pays d'Europe et couvre les domaines suivants:

Pièces en tôle: 1 mois à compter de la date d'achat.

Pièces électriques: 1 mois à compter de la date d'achat..

GARANTIE

GEWÄHRLEISTUNGSANSPRÜCHE

Es gibt eine 30-tägige Garantie für kaputte Möbel oder andere Probleme, die nicht richtig funktionieren. Die Garantie beginnt mit dem Kaufdatum, das verifiziert durch Kaufbeleg.

Bevor Sie einen Anspruch geltend machen, können wir Ihre Anfrage möglicherweise beantworten. Rufen Sie uns einfach an. Bitte hinterlassen Sie Ihre Bestellnummer zusammen mit einigen Details des Problems, wenn Sie ein Ersatzteil wünschen. Wir werden innerhalb von 48 Stunden arrangieren. Wenn es nicht vorrätig ist, werden wir mit einem Versanddatum antworten.

Das Produkt muss gemäß den mitgelieferten Anweisungen verwendet werden.

Wenn die Möbel aus anderen Gründen zurückgegeben werden müssen, müssen sie innerhalb von 30 Tagen nach Erhalt gereinigt, getrocknet und in Betrieb genommen werden.

Art des Garantieanspruchs

Die Nichtbeachtung der Möbelanweisungen führt zum Ausfall der Garantie. Bitte beachten Sie. Beinhaltet keine Schäden während der Installation, aber Schäden während des Transports.

Verantwortungsbereich

Übernimmt keine Verantwortung für Missbrauch oder Benutzerschäden und / oder Verlust von Teilen während der Installation von Möbeln.

Nach dem Gebrauch sind die Schäden und Kratzer der Möbel nicht von der Garantie abgedeckt.

Die Garantie bezieht sich auf alle in den USA und Europa gekauften und deckt die folgenden Bereiche ab

Blechteile: 1 Monat ab Kaufdatum.

Elektrische Teile: 1 Monat ab Kaufdatum.

RETURNS

CHANGED YOUR MIND AND NEED TO RETURN YOU ITEM?

PLEASE FOLLOW THE BELOW INSTRUCTIONS:

- If you have purchased and have simply changed your mind, follow the retailer's instructions for returns.

DEFECTIVE ITEMS

- If your item is defective in any way, i.e. it doesn't work but you can't identify why, in the first instance, please call us.

DAMAGED ITEMS

- If you receive an order with obvious shipping damage from the retailer, then we suggest the delivery is refused. If the delivery has been accepted and then shipping damage is found, please follow the specific instructions advised by the retailer. In all circumstances please save all packaging material and paperwork for the order. Please be aware that if you dispose of packaging material or attempt to return the merchandise without contacting the fulfiller, you jeopardise your chances of making a claim, and you may not receive a credit for the return.

AFTER-SALES CONTACT



adelahu@fufugaga.com



208-820-0068

RETOUR

VOUS AVEZ CHANGE D'AVIS ET VOUS AVEZ BESOIN DE RETOURNER VOTRE ARTICLE ?

VEUILLEZ SUIVRE LES INSTRUCTIONS CI-DESSOUS:

Si vous avez acheté et que vous avez simplement changé d'avis, suivez les instructions du détaillant pour les retours.

ARTICLES DÉFECTUEUX

Si votre article est défectueux de quelque manière que ce soit, c'est-à-dire qu'il ne fonctionne pas, mais que vous ne pouvez pas identifier pourquoi, en premier lieu, veuillez nous appeler.

ARTICLES ENDOMMAGÉS

Si vous recevez une commande avec des dommages d'expédition évidents du détaillant, nous suggérons que la livraison soit refusée. Si la livraison a été acceptée et que des dommages d'expédition sont constatés, veuillez suivre les instructions spécifiques conseillées par le détaillant.

Dans tous les cas, veuillez conserver tout le matériel d'emballage et les documents pour la commande.

Veuillez noter que si vous vous débarrassez du matériel d'emballage ou tentez de retourner le

Marchandise Sans contacter le remplisseur, vous compromettez vos chances de faire une réclamation, et vous ne pouvez pas recevoir de crédit pour le retour.



Rücksendung

SIE HABEN IHRE MEINUNG GEÄNDERT UND MÜSSEN IHREN ARTIKEL ZURÜCKGEBEN?

BITTE BEFOLGEN SIE DIE FOLGENDEN ANWEISUNGEN:

Wenn Sie gekauft haben und einfach Ihre Meinung geändert haben, befolgen Sie die Anweisungen des Händlers für die Rückgabe.

DEFEKT EARTIKEL

Wenn Ihr Artikel in irgendeiner Weise defekt ist, d.h. es funktioniert nicht, aber Sie können nicht erkennen, warum in erster Instanz, rufen Sie uns bitte an.

BESCHÄDIGTE ARTIKEL

Wenn Sie vom Händler eine Bestellung mit offensichtlichen Transportschäden erhalten, schlagen wir vor, die Lieferung abzulehnen. Wenn die Lieferung angenommen wurde und ein Transportschaden festgestellt wird, befolgen Sie bitte die spezifischen Anweisungen des Händlers. Bitte bewahren Sie in jedem Fall alle Verpackungsmaterialien und Papiere für die Bestellung auf.

Bitte beachten Sie, dass Sie Ihre Chancen auf eine Reklamation gefährden, wenn Sie Verpackungsmaterial verlieren oder versuchen, die Ware zurückzusenden, ohne sich den Kundendienst zu kontaktieren, und dass Sie möglicherweise keinen Betrag für die Rücksendung erhalten.

Hinweis: Die Waren müssen in der Originalverpackung, vollständig und in unbenutztem und unbeschädigtem Zustand an den Verkäufer zurückgeschickt werden.

