

# **ASSEMBLY INSTRUCTIONS**

## **IMPORTANT** **PLEASE READ BEFORE YOU CONTINUE FURTHER**

### **ASSEMBLY PREPARATION**

1. Remove all packaging materials, staples, and packing straps from the carton.
2. Refer to the Parts List and Hardware List to ensure all parts and hardware are correct before starting assembly.
3. Place all wooden parts on a clean, flat, and soft surface (e.g., carpet or rug) to prevent scratches and damage.

### **SAFETY PRECAUTIONS**

1. KEEP ALL HARDWARE PARTS OUT OF REACH OF CHILDREN.
2. DISPOSE OF PLASTIC PACKAGING MATERIALS IMMEDIATELY TO AVOID ANY RISK OF SUFFOCATION TO CHILDREN AND ANIMALS.

### **TIPS FOR ASSEMBLY**

1. Ensure ample space for assembly and position the area close to where the product will be placed.
2. Assemble the product on a surface that will not scratch or damage the exterior gloss or finishing of the furniture.
3. Identify all parts, hardware, and quantities required for each step.
4. Avoid over-tightening any fittings during assembly, as this may cause damage.
5. Use hand tools only--DO NOT USE POWER TOOLS TO ASSEMBLE THIS PRODUCT.
6. Always assemble the product on a flat, level surface.
7. Assembly requires two or more people--do not attempt to assemble the product alone, as there is a risk of injury.
8. Do not sit or stand on the partially assembled product. Use the product only for its intended purpose.

### **WARNINGS**

1. This product is intended for indoor and household use only, and is not suitable for commercial use.
2. Hardware may loosen over time. Regularly check all connections and re-tighten as needed.
3. Dining chairs are designed for normal use with all four legs on the ground. Do not sit in the chairs with only two legs on the ground (e.g., tipping back, forward, or sideways), as this may stress and damage the chair legs.
4. Do not stand on the chair.





- DO NOT STAND ON THE CHAIR
- DO NOT SIT IN THE CHAIR WITH ONLY TWO LEGS

**Please make sure you have all these parts before you start.**

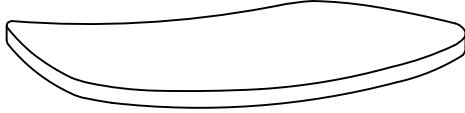
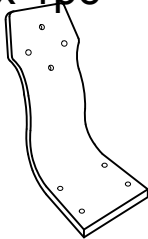
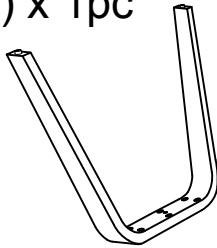
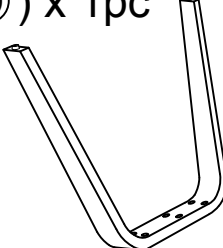
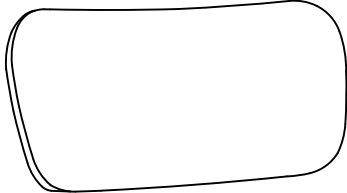
**PART LIST**

<p>①(or ①A) x 1pc</p> 	<p>②(or ①B) x 1pc</p> 
<p>③(or ①C) x 1pc</p> 	<p>④(or ①D) x 1pc</p> 
<p>⑤(or ①E) x 1pc</p> 	

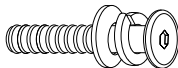
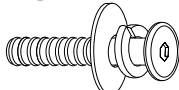
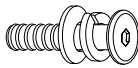
**HARDWARE LIST**

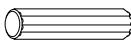
<p>①A(or ①) x (12pcs+1)</p>  <p>JCBC M6 x 30mm + S/W M6 + F/W M6 x 13mm</p>	<p>①B(or ②) x (4pcs+1)</p>  <p>JCBC M6 x 30mm + S/W M6 + F/W M6 x 19mm</p>	<p>①C(or ③) x (2pcs+1)</p>  <p>JCBC M6 x 20mm + S/W M6 + F/W M6 x 13mm</p>
<p>①D(or ④) x 1pc</p>  <p>ALLEN KEY M4 (BALL SHAPE)</p>	<p>①E(or ⑤) x (4pcs+1)</p>  <p>DOWEL M8 x 20mm</p>	

(Extra Hardware for spare use)

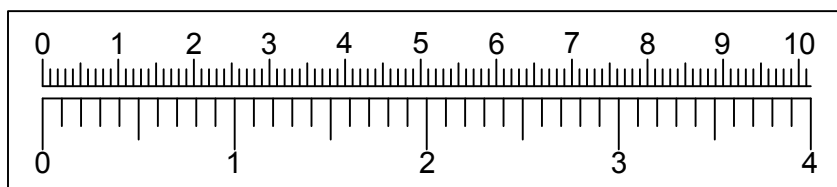

## STEP 1

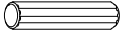
5	 DOWEL M8 x 20mm	2PCS
---	--	------

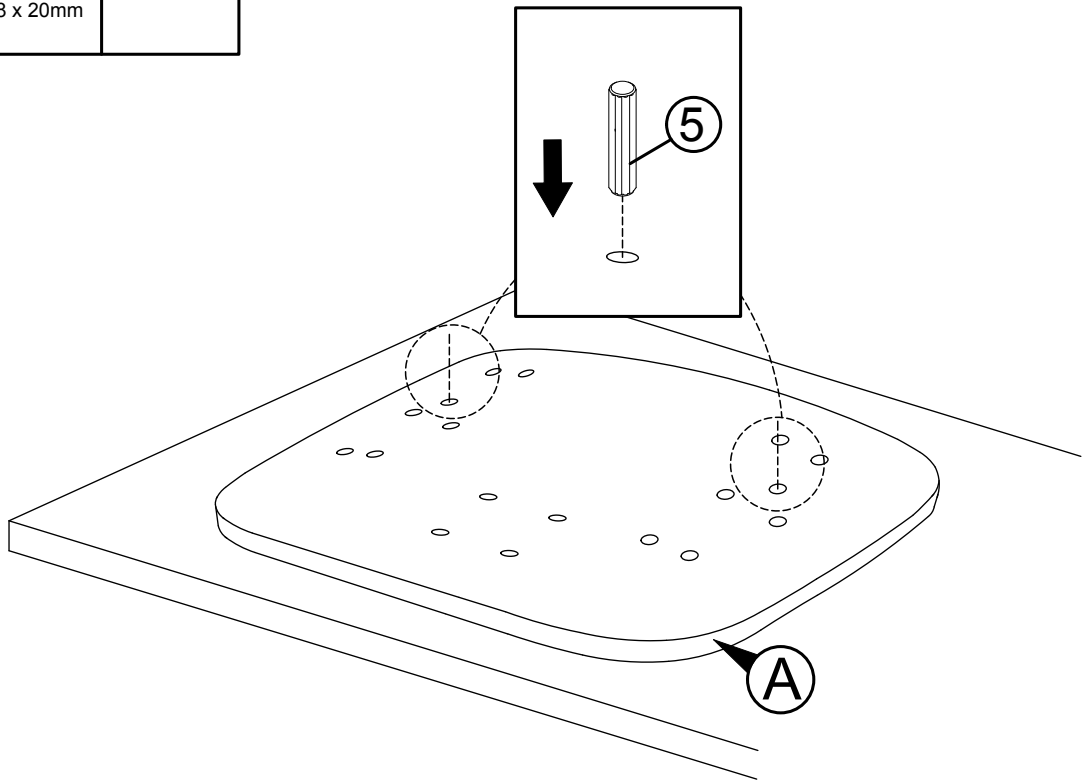

## STEP 2

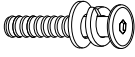
1	 JCBC M6 x 30mm + S/W M6 + F/W M6 x 13mm	6PCS
---	--	------

**Tighten all bolts slightly loose. Once aligned, fully tighten all bolts but do not over-tighten.**

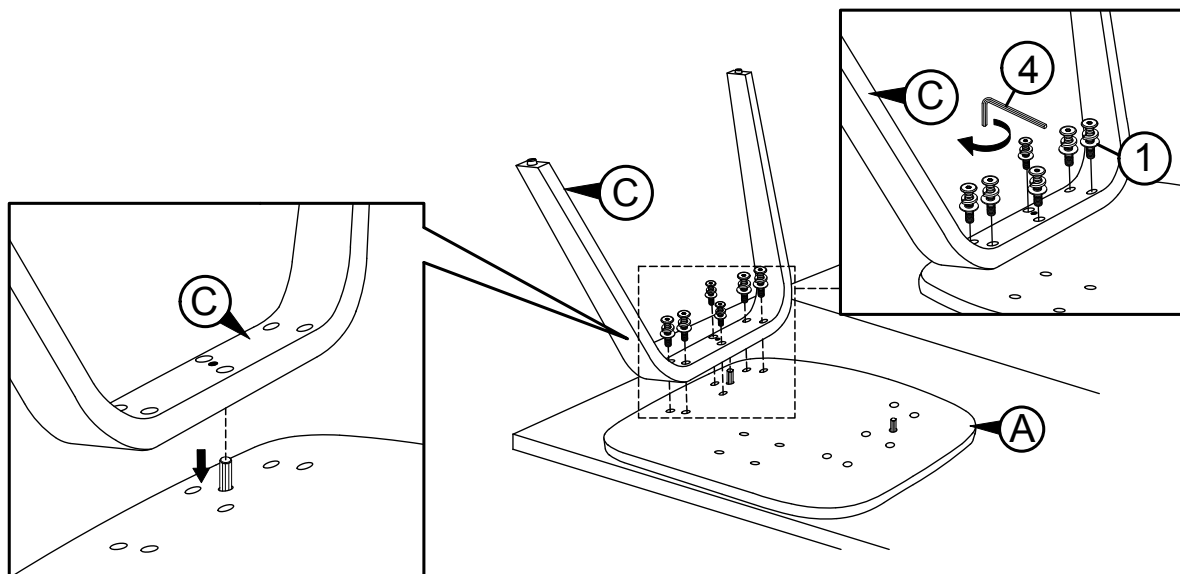

### STEP 3

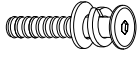
1	 JCBC M6 x 30mm + S/W M6 + F/W M6 x 13mm	6PCS
---	--	------

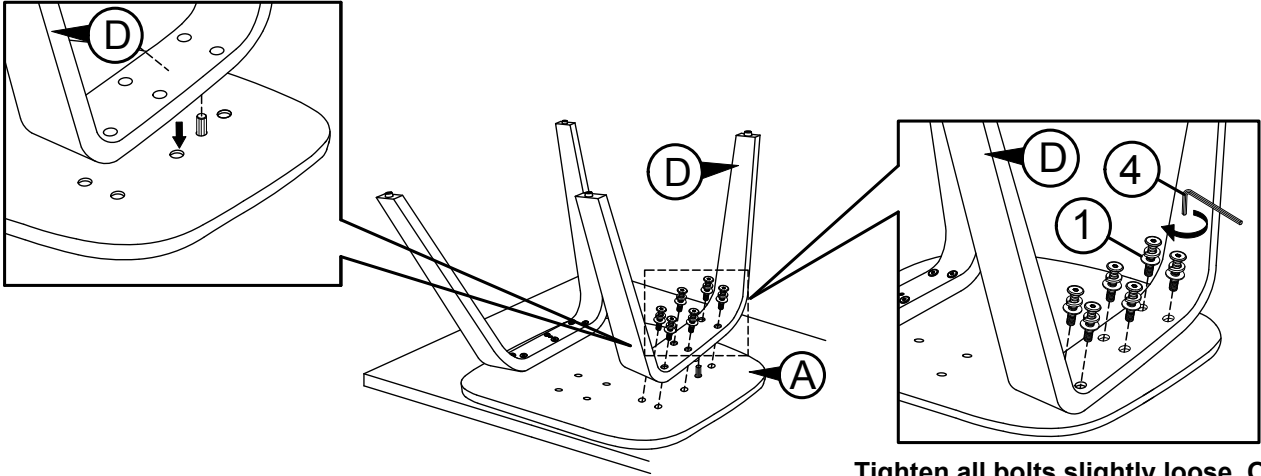

Tighten all bolts slightly loose. Once aligned, fully tighten all bolts but do not over-tighten.

### STEP 4

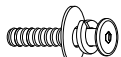
2	 JCBC M6 x 30mm + S/W M6 + F/W M6 x 19mm	4PCS
---	--	------

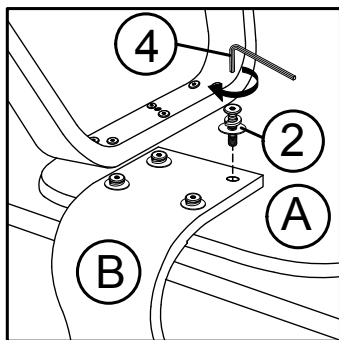

Tighten all bolts slightly loose. Once aligned, fully tighten all bolts but do not over-tighten.

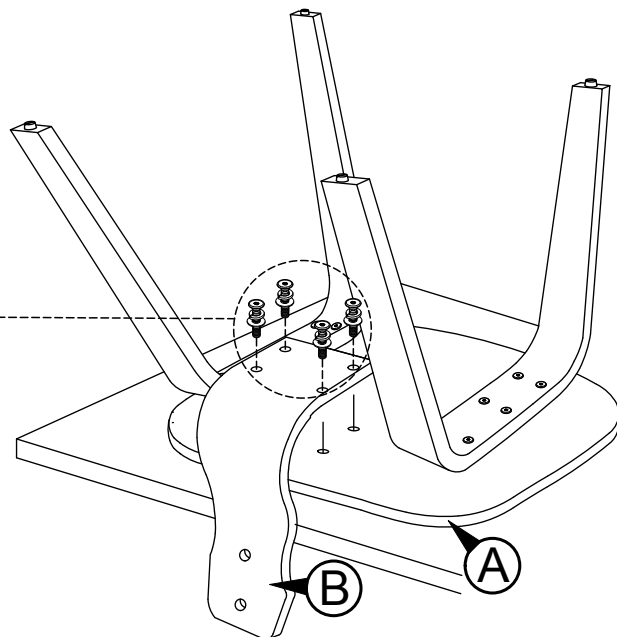

## STEP 5

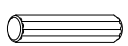
3	 JCBC M6 x 20mm + S/W M6 + F/W M6 x 13mm	2PCS
5	 DOWEL M8 x 20mm	2PCS

Step 5b :

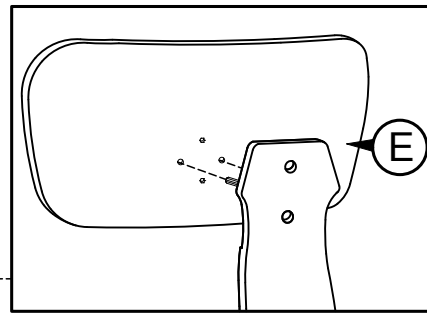

Step 5a :

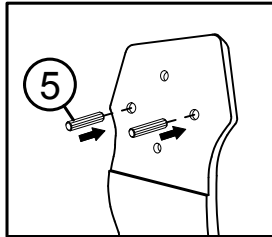

Step 5c :

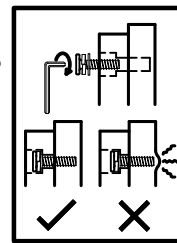
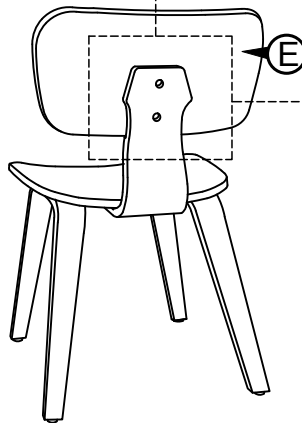
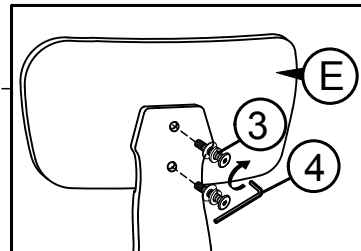

Fully tighten all bolts  
but do not  
over-tighten.

## STEP 6

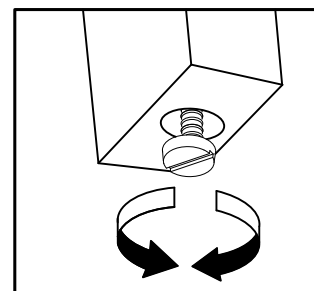
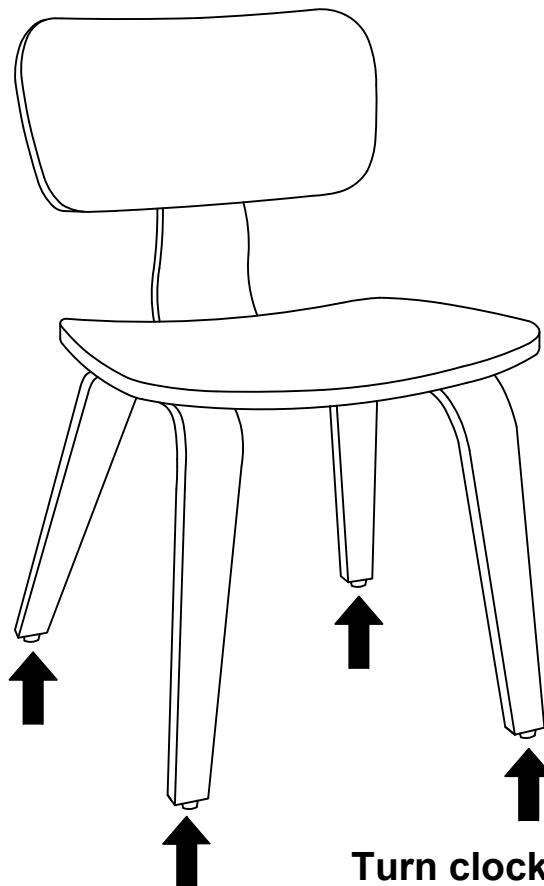

Turn clockwise or anti-clockwise  
to adjust leg leveller.