

Assembly Instructions

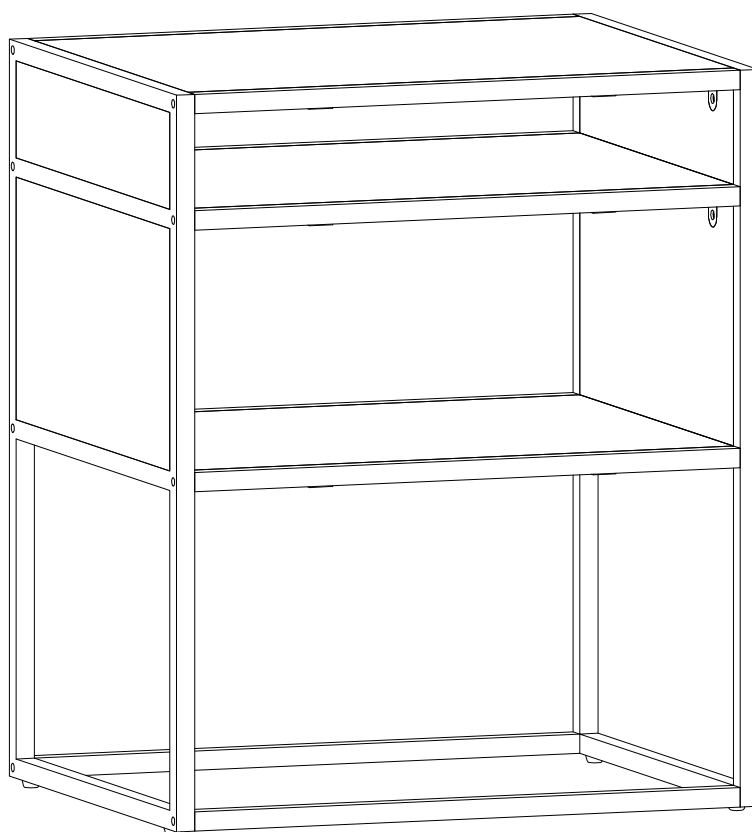

General Assembly Guidelines

- I. Ensure that all parts and hardware are available before beginning assembly.
- II. Follow each step carefully to ensure the proper assembly of this product.
- III. Two people are recommended for ease in the assembly of this product.
- IV. The two main types of hardware used to assemble this product are :
screws and bolts.
- V. A Phillips head screwdriver is required for the assembly of this product .

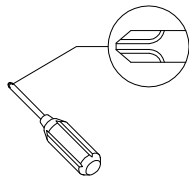

- VI. Power tools should not be used to assemble this product .

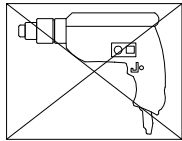

Parts List

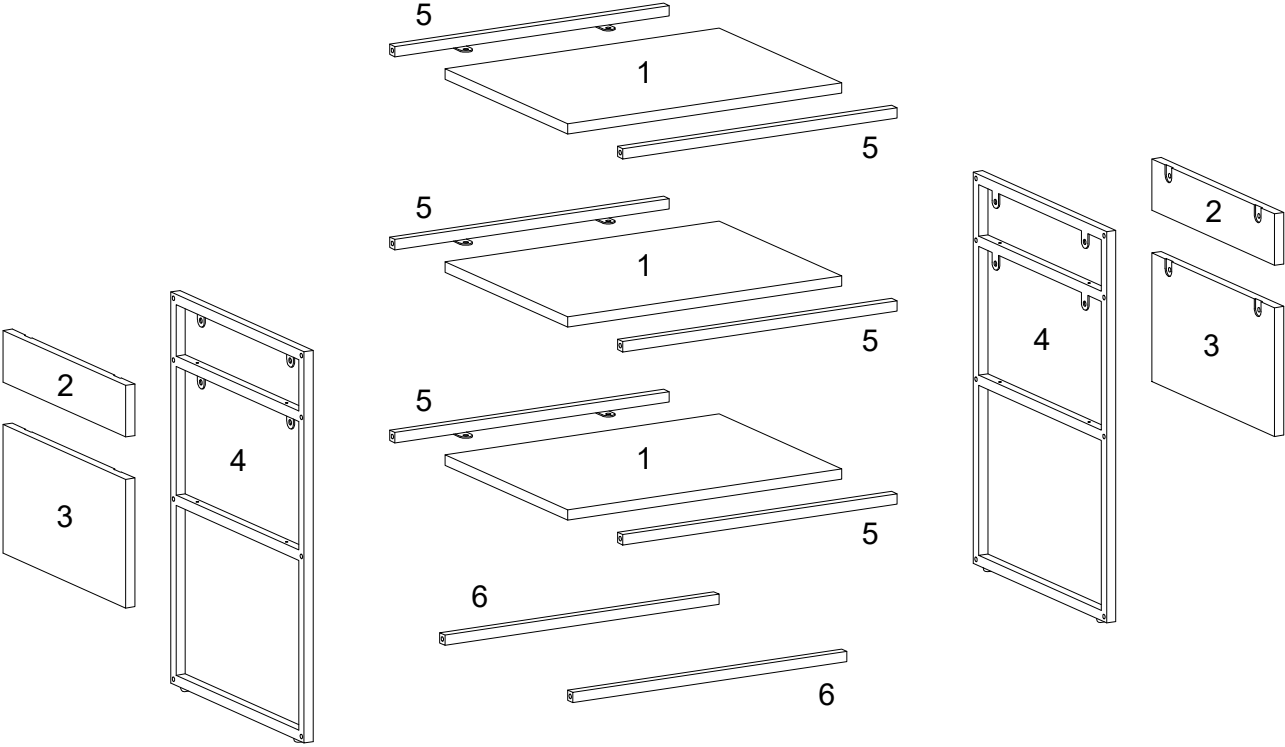

Hardware List

A		Ø6x30mm	Bolt	16 pcs
B		Ø6x12mm	Bolt	20 pcs
C		Ø4x35mm	Screw	8 pcs
D		Ø16x1/4"	Adjuster	4 pcs
E		M 4	Hex Key	1 pcs

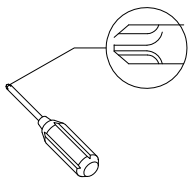

Philips head screwdriver required for assembly
(not included)

*The hardware quantities listed above are required for proper assembly.
Some extra hardware may also have been included.*

Step 1

x 3

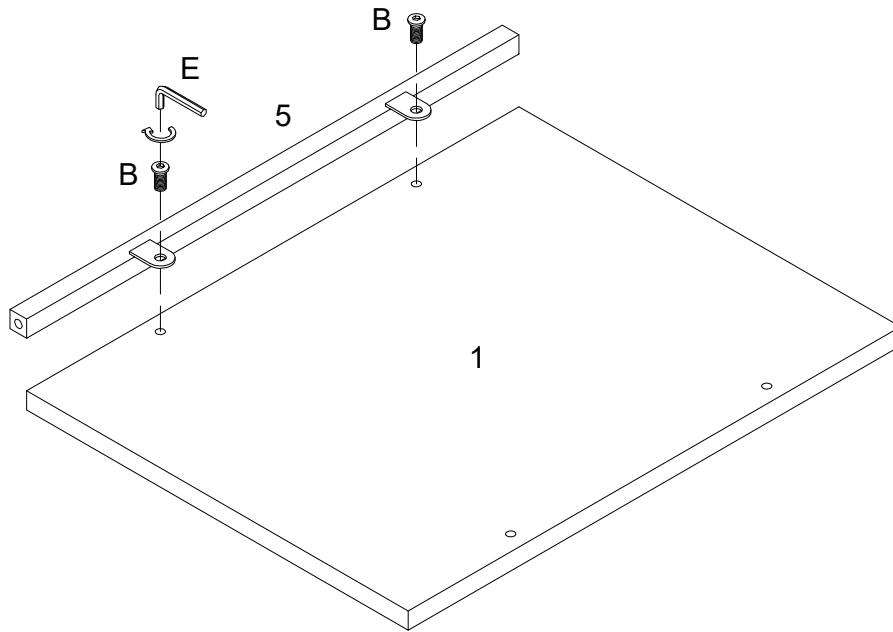

Attach part (5) to part (1) using bolt (B) with hex key (E).

Step 2

x 3

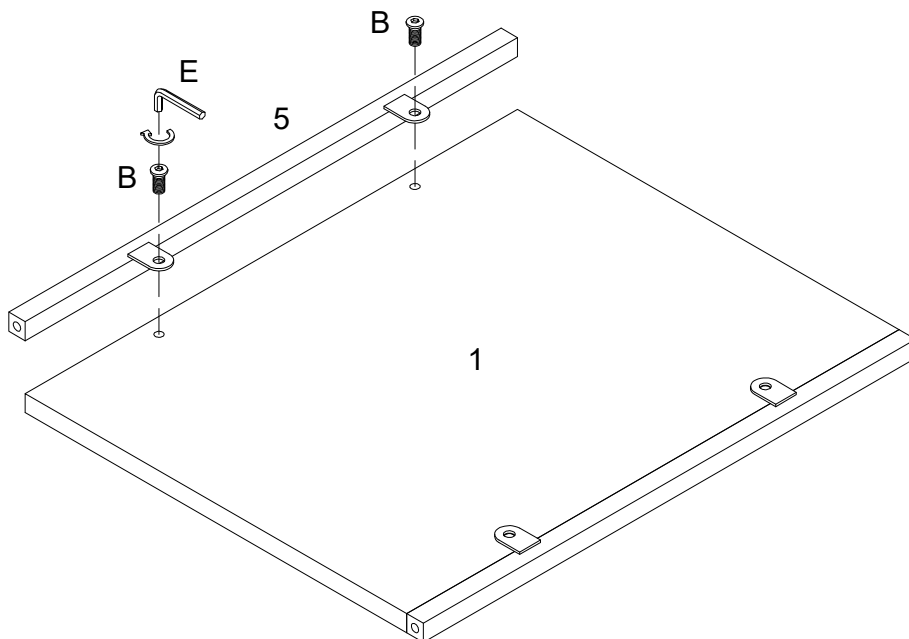

Attach part (5) to part (1) using bolt (B) with hex key (E).

Step 3

x 2

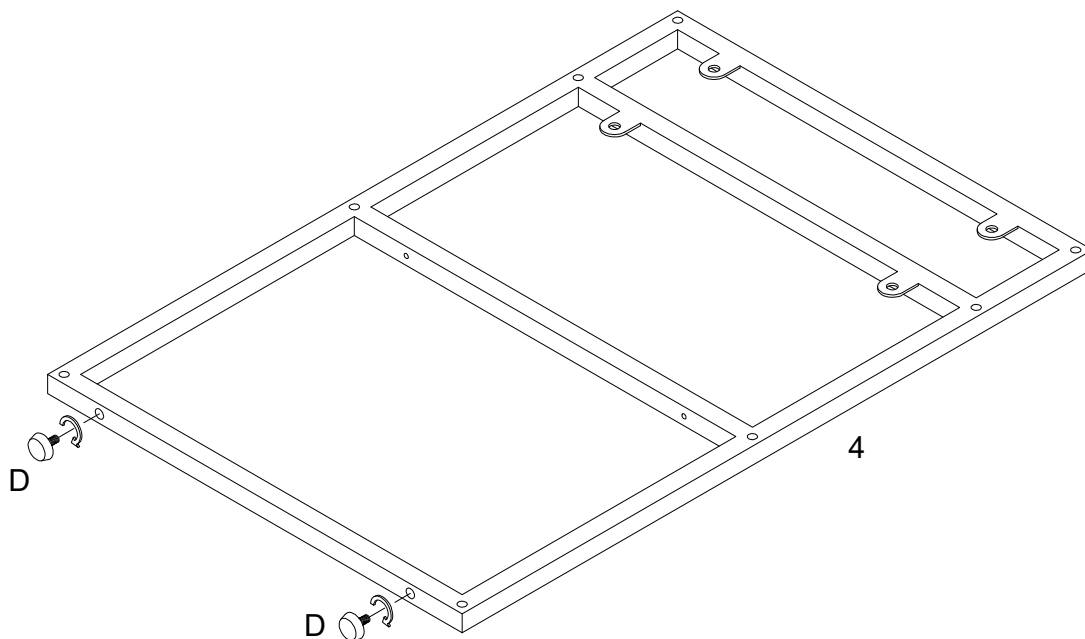

Attach adjuster (D) to part (4).

Step 4

x 2

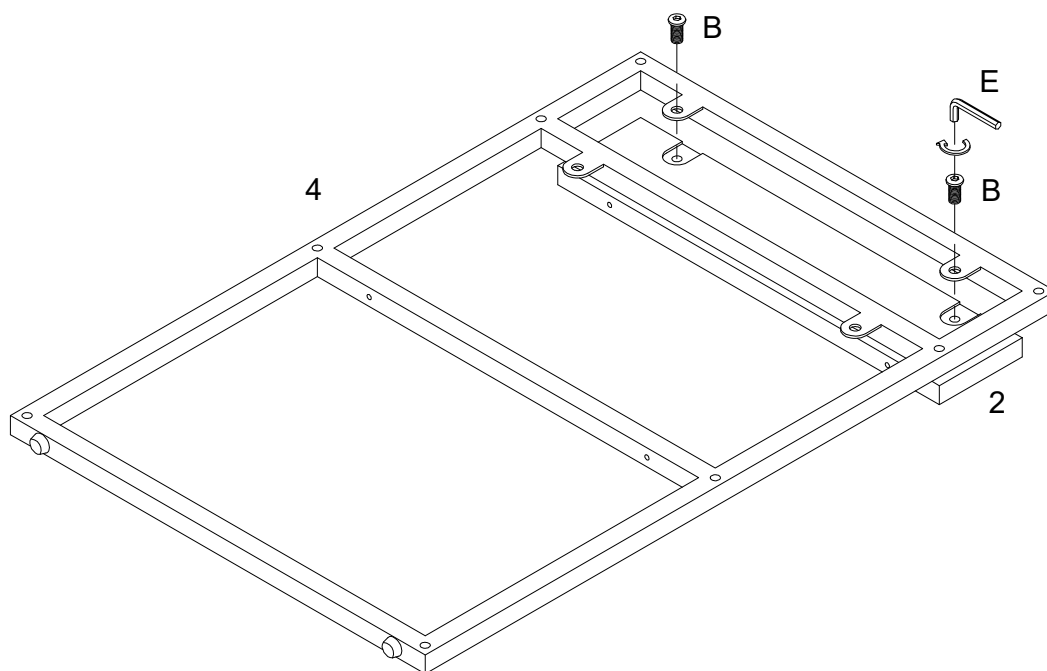

Attach part (4) to part (2) using bolt (B) with hex key (E).

Step 5

x 2

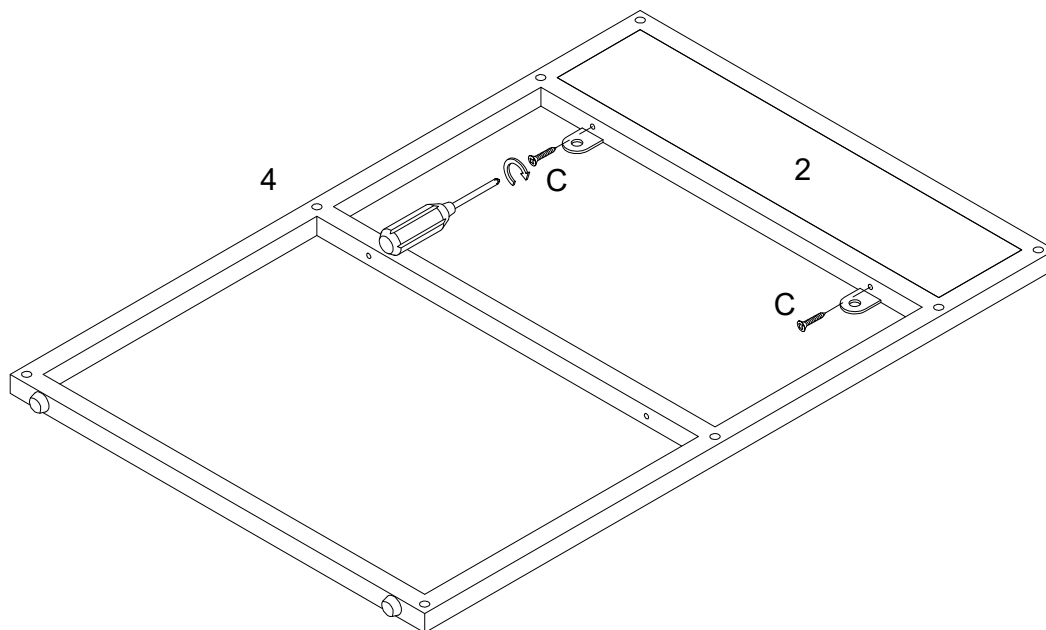

Attach part (4) to part (2) using screw (C) with screwdriver.

Step 6

x 2

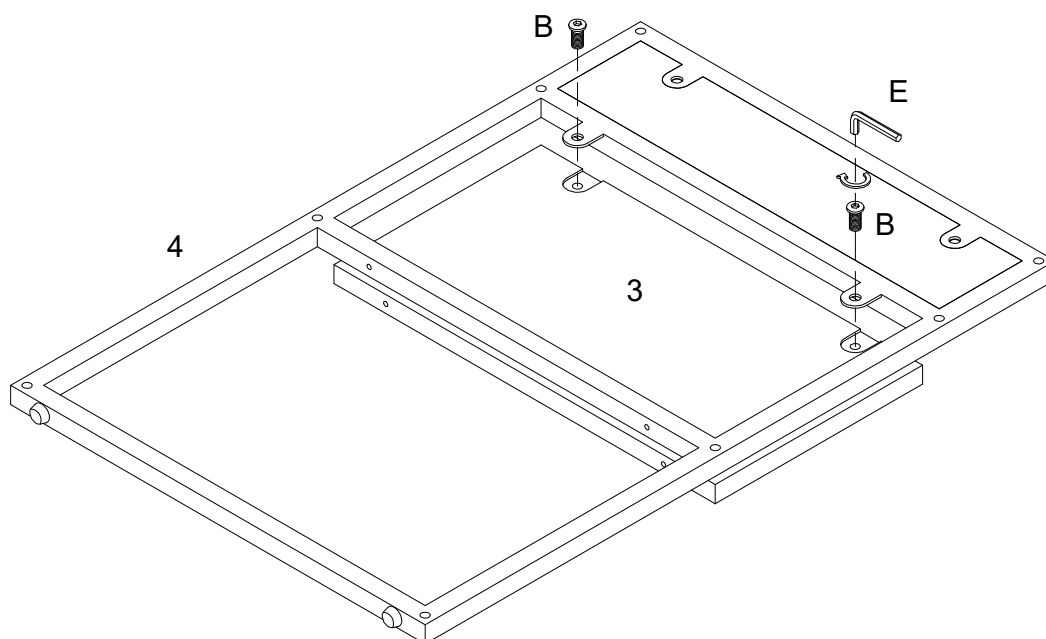

Attach part (4) to part (3) using bolt (B) with hex key (E).

Step 7

x 2

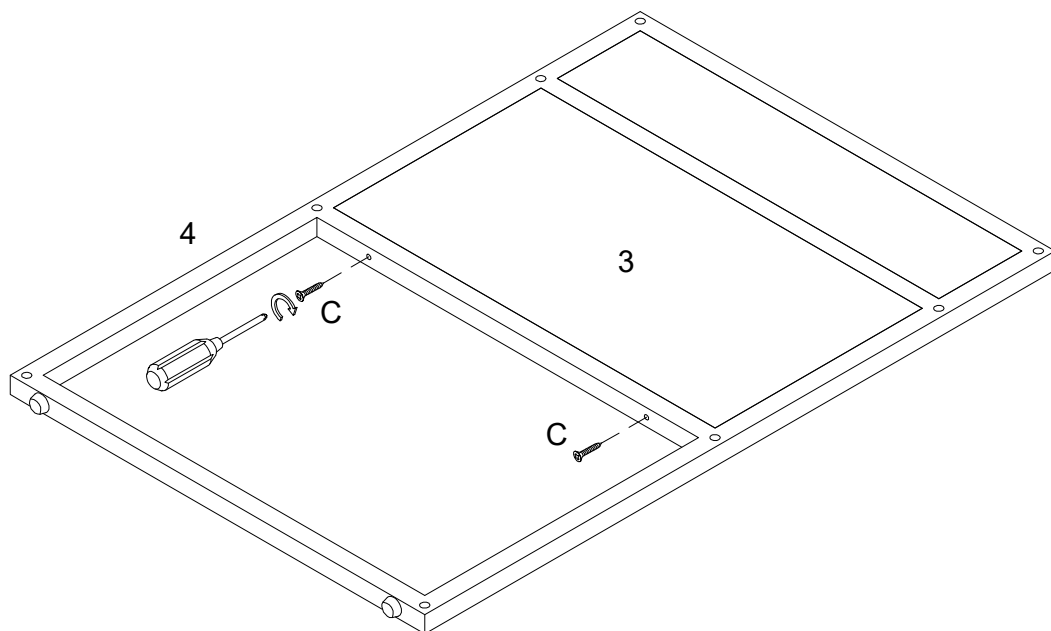

Attach part (4) to part (3) using screw (C) with screwdriver.

Step 8

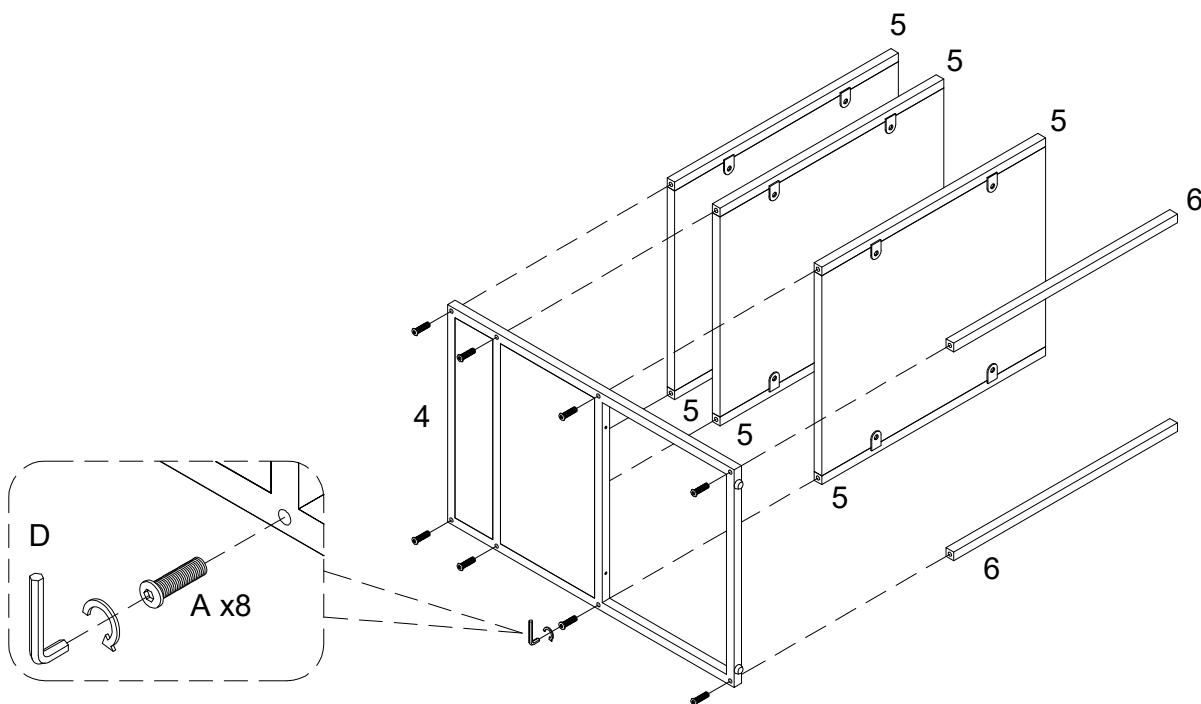

Attach part (4) to part (5,6) using bolt (A) with hex key (D).

Step 9

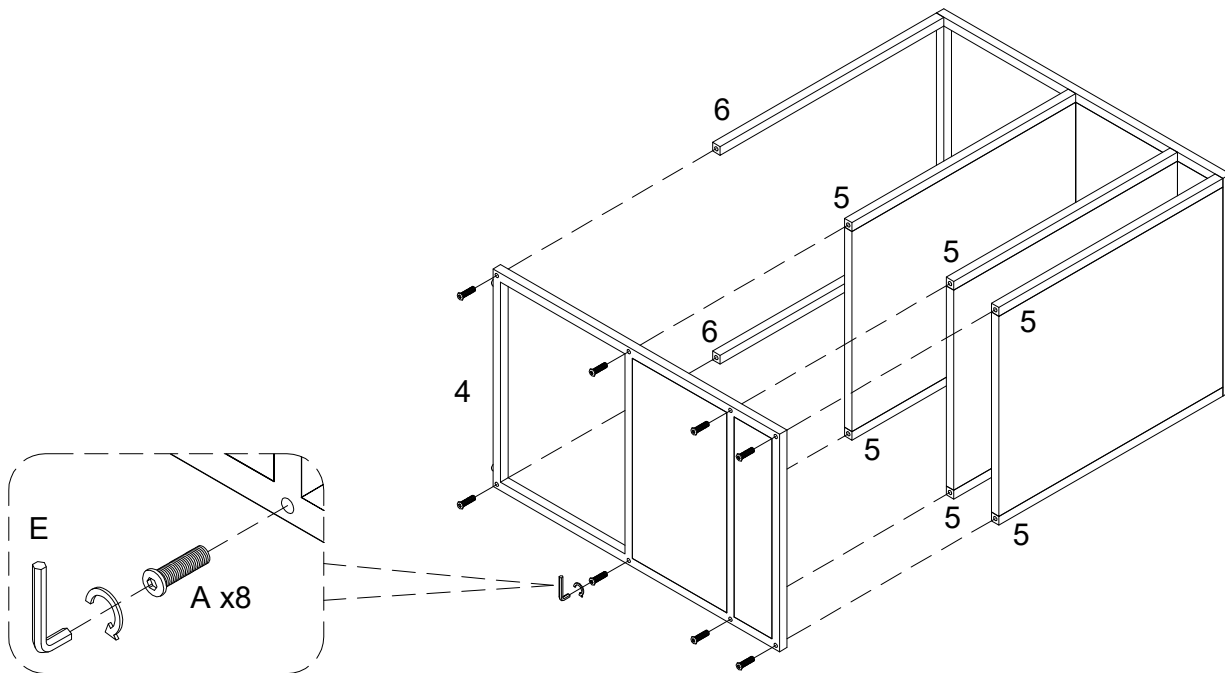

Attach part (4) to part (5,6) using bolt (A) with hex key (D).

Step 10

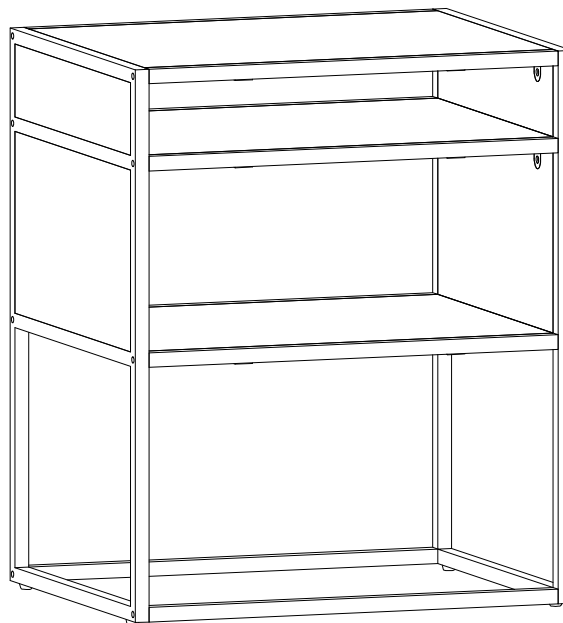

Final Assembly