

Assembly Instructions

3131431 Accent Chair - Cinnamon

Product Issues? Please Call Us Before Contacting Your Retailer At 1-800-549-3300.

Email customerservice@mshome.co, visit www.mshome.co

We can help with Assembly Issues, Part Requests, Damages, & All Other Product Related Questions

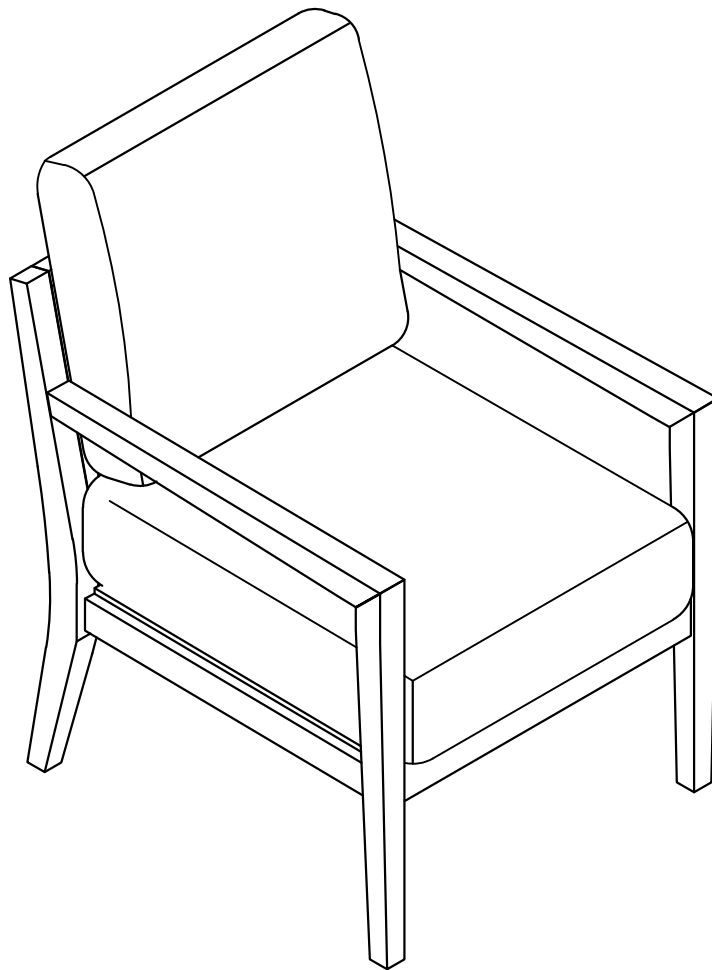

MSH - USA

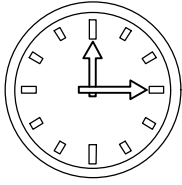

15 min

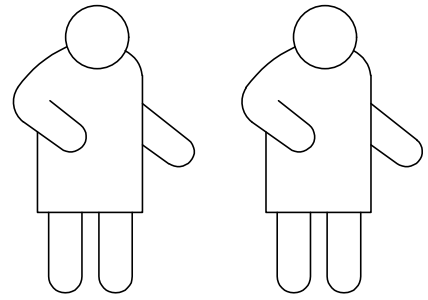

Two People Required
for Assembly

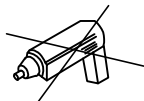
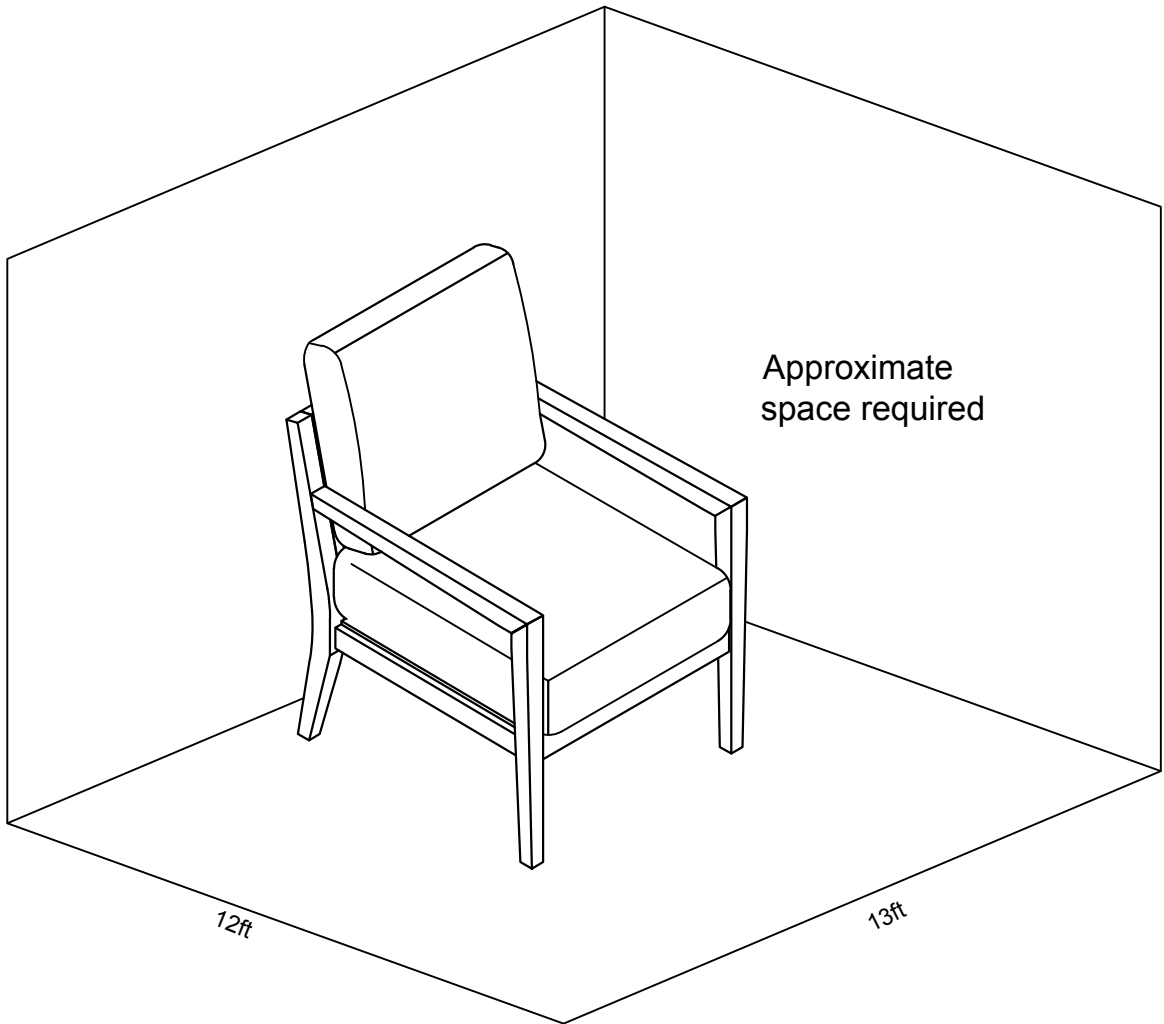

Do Not Use Power Tools

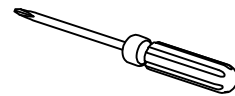





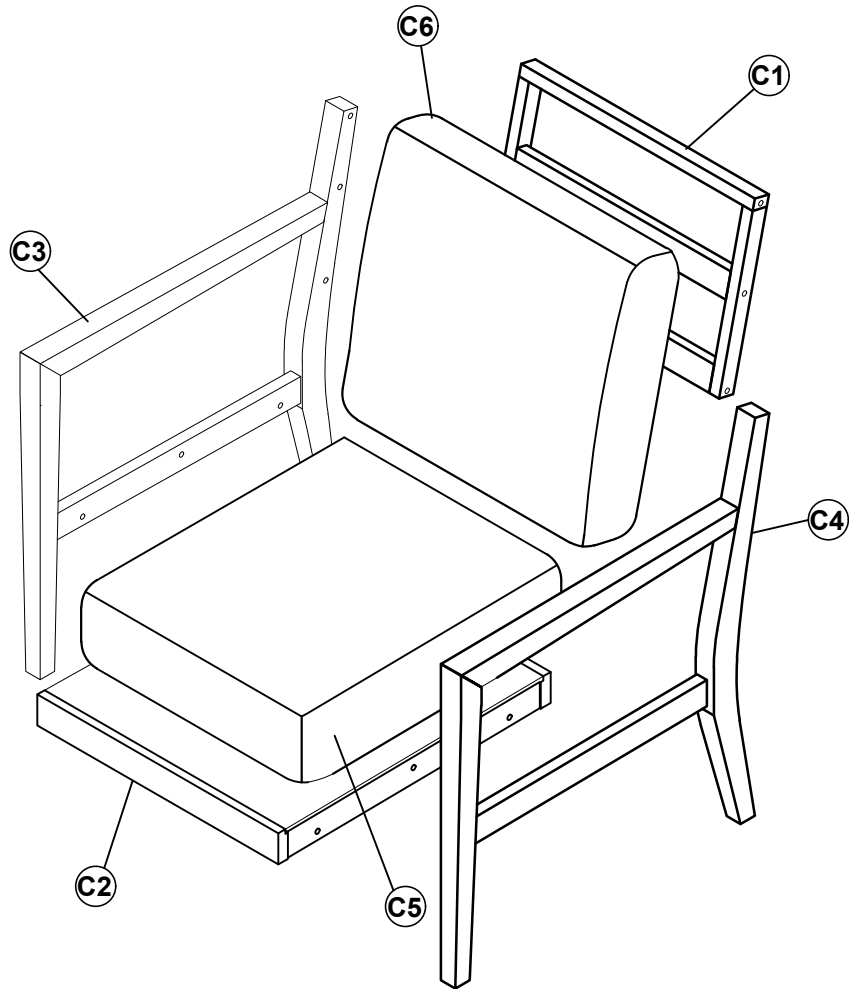

Phillips Head (Not Provided)

PARTS INCLUDED

- (C1) Chair Back x1
- (C2) Seat Frame x1
- (C3) Left Frame x1
- (C4) Right Frame x1
- (C5) Cushion Seat x1
- (C6) Cushion Back x1



Hardware Pack

<p>A  Ø5/16"x45 (mm) : 6pcs</p>	<p>B  Ø1/4"x70 (mm) : 4pcs</p>	<p>C  Ø5/16"x13x1.5: 6pcs</p>
<p>D  Ø5/16"x19x1.5: 6pcs</p>	<p>E  Ø8x30mm: 4pcs</p>	<p>F  Allen Key 4mm : 1pcs</p>

1

E x 4

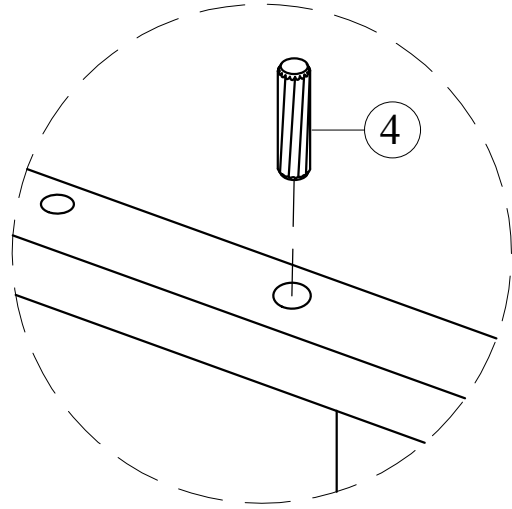
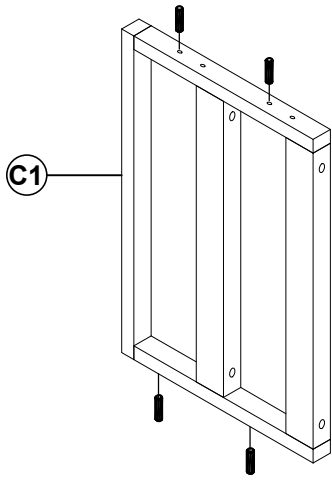



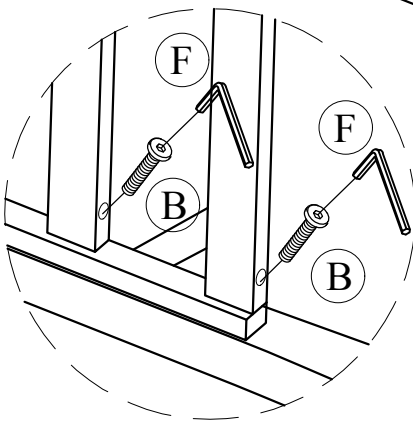
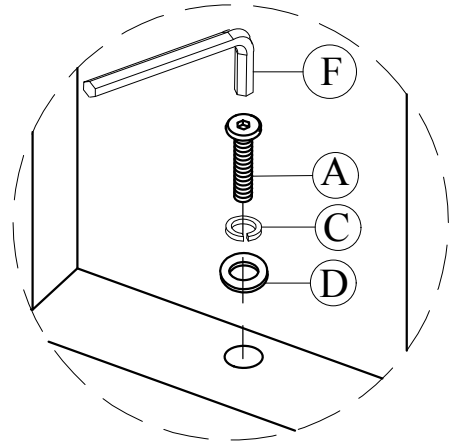
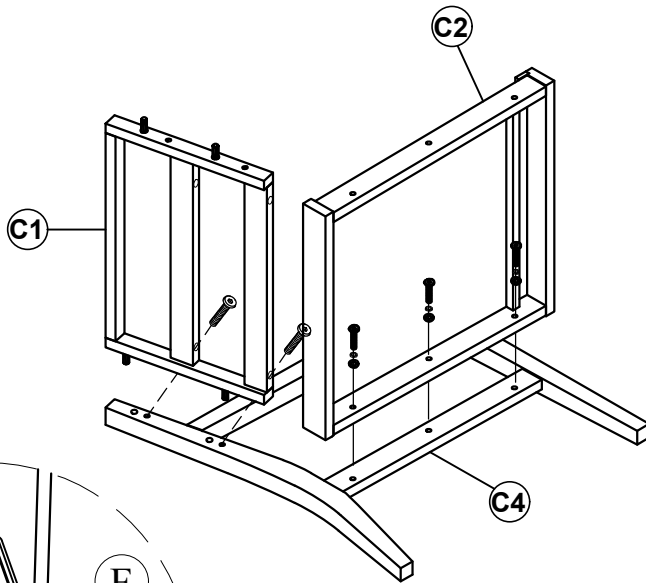

2

A x 3		C x 3		D x 3	
B x 2		F x 3			

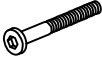

3

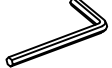
A x 3		C x 3		D x 3	
B x 2		F x 1			

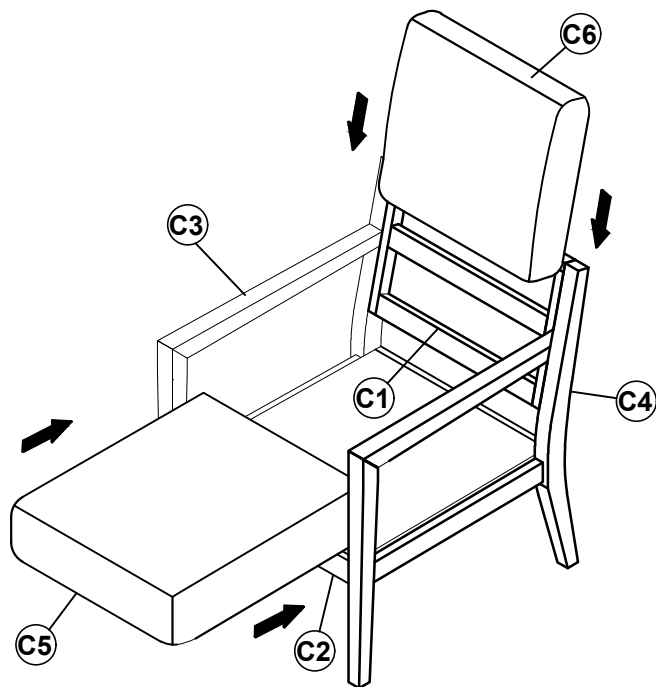
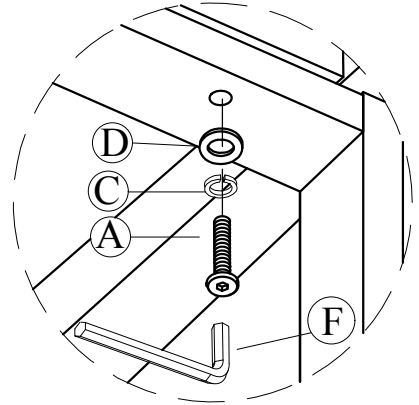
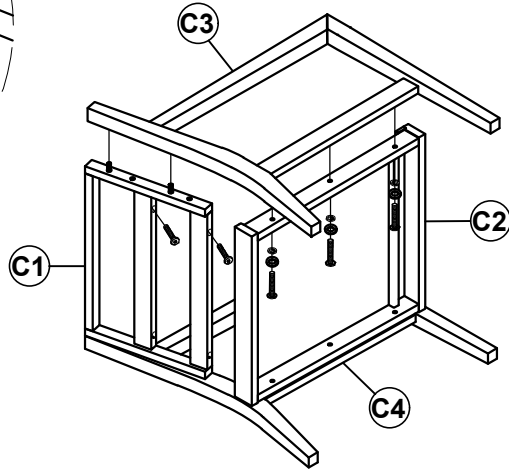
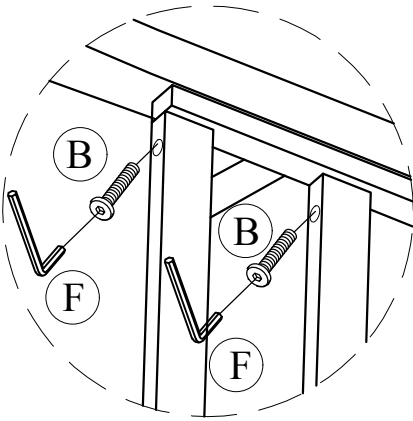

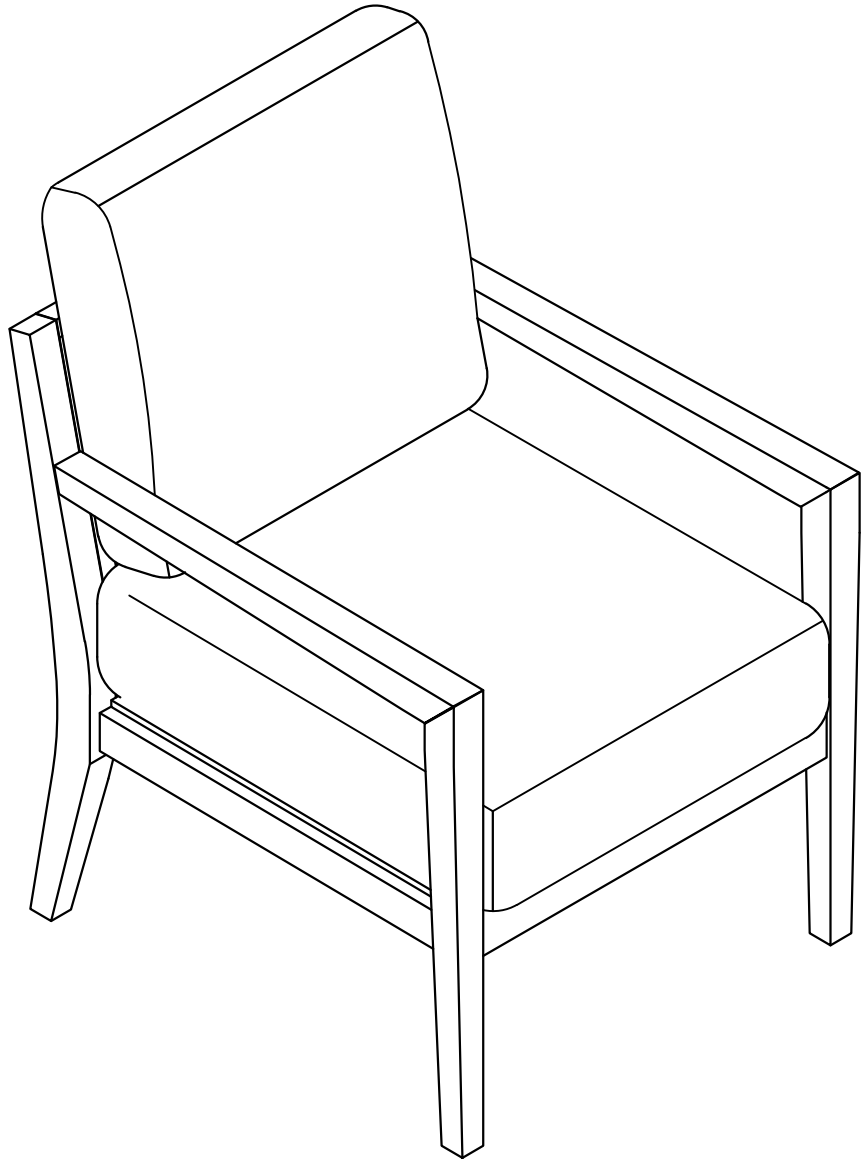

MARTIN SVENSSON
Home

Replacement Part Form

Have an issue? Need a replacement part?

Please E-mail us before contacting your retailer, we will be happy to fix your issue.

This process will be hassle free! We will replace your part for free!

Please follow these easy steps below.

**You will need to E-mail Martin Svensson Home Customer Service:
Customerservice@mshome.co**

(Please note it is .CO not .com)

Please scan or take a picture of this form filled out.

1. Customer Name: _____

2. SKU# with issue: _____

3. Replacement Part # needed _____

a. *Please reference the Assembly Instructions to identify needed part #'s

4. Photos of the Damaged Part (please include in the e-mail)

5. Brief description of the part issue: _____

6. Proof of Purchase (please provide a copy of your purchase receipt)

7. Ship to Address: _____

8. Other contact information:

a. **Email Address** _____

b. **Phone #** _____

*If possible, could you please provide the UPS or FedEx tracking from original shipment _____

*If possible, could you please provide the P.O. # - information found on back/underneath product _____

*If you have any other question, we are happy to assist with assembly questions or all other parts related

questions. Thank you for your purchase!