









ASSEMBLY INSTRUCTIONS

NO.	Parts List		Q' TY
A		Chair Back	1
B		Chair Seat	1
C		Front Leg	2

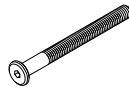
NO.	Parts List			Q' TY
H1		Ø8 x 55mm	Allen Head Bolt	4
H2		Ø8 x 85mm	Allen Head Bolt	4
H3		Ø8 x 40mm	Allen Head Bolt	1
H4		Ø9 x Ø13mm	Lock Washer	9
H5		Ø8 x Ø20mm	Flat Washer	9
H6		4 x 110mm	Allen Key	1

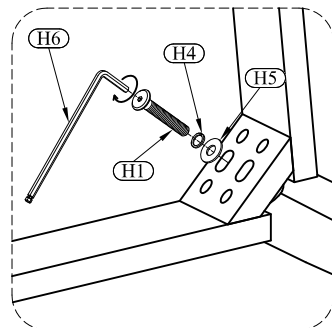

STEP 1

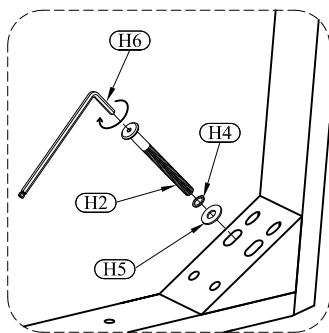
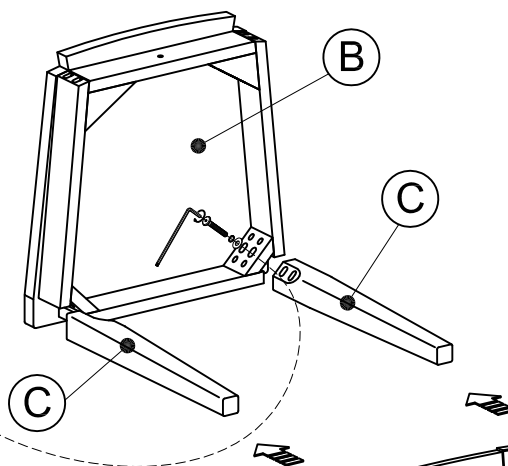

STEP 2

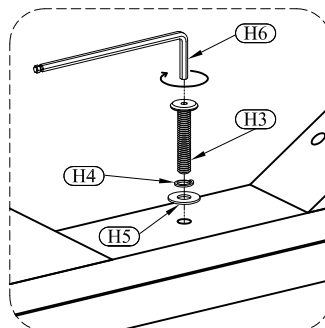
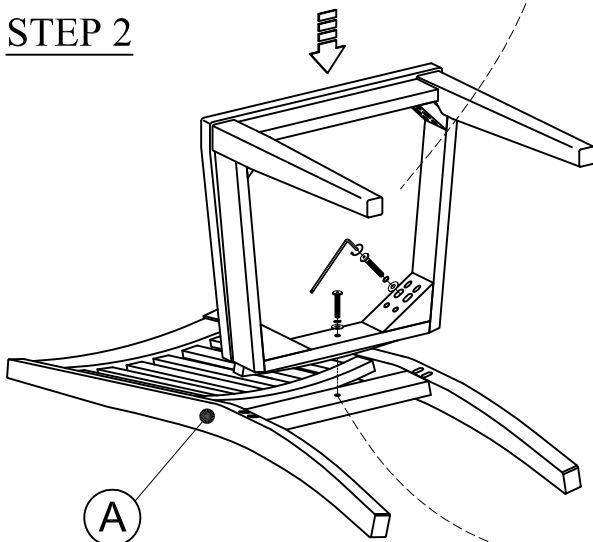

FINISH

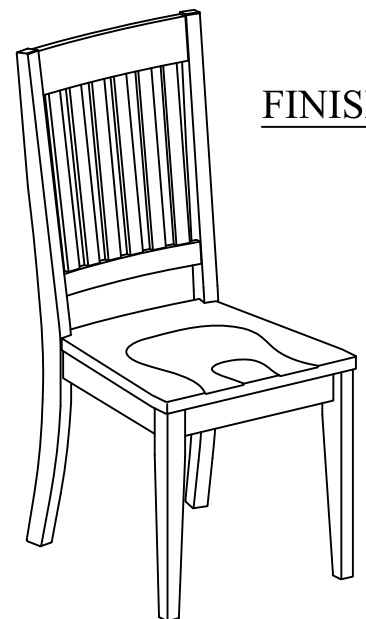

** TURN THE CHAIR TO THE STANDING POSITION. CHECK IT'S BALANCE AND TIGHTEN ALL SCREW TO COMPLETE THE ASSEMBLY