

Instruction Manual(EN)/Bedienungsanleitung(DE)

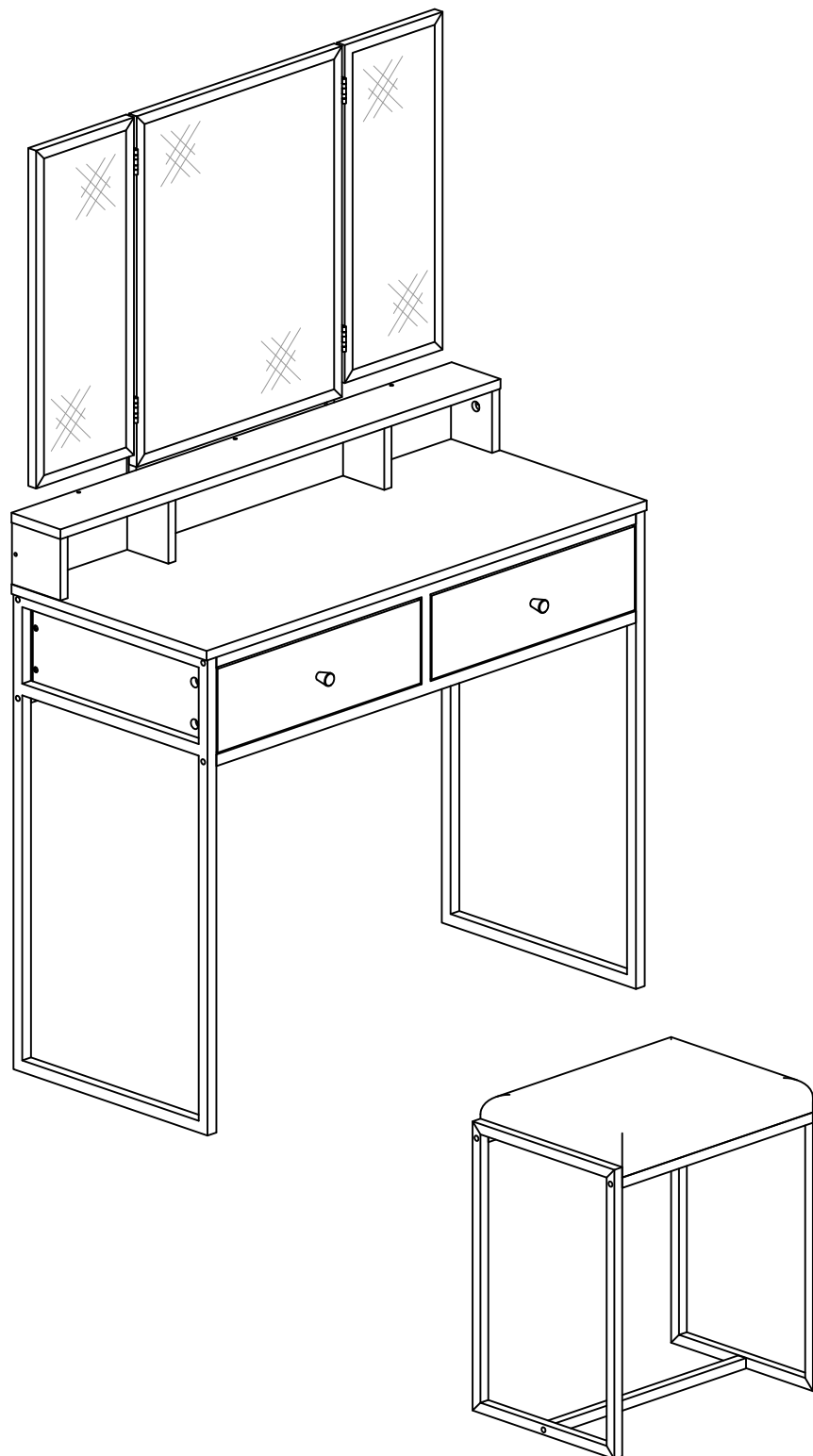

Thank you for purchasing this quality product. Be sure to check all packing material carefully for small parts which may have come loose inside the carton during shipment. Identify and count all parts and compare with the part list below:

Do not tighten screws & bolts until the entire item is completely assembled.

Vielen Dank, dass Sie sich für den Kauf unseres Qualitätsprodukts entschieden haben. Bitte überprüfen Sie das gesamte Verpackungsmaterial sorgfältig auf Kleinteile, die sich während des Transports im Karton gelöst haben könnten. Identifizieren und zählen Sie alle Teile und vergleichen Sie diese mit der untenstehenden Teileliste:

Ziehen Sie Schrauben und Bolzen erst fest, wenn das gesamte Möbel vollständig zusammengebaut ist.

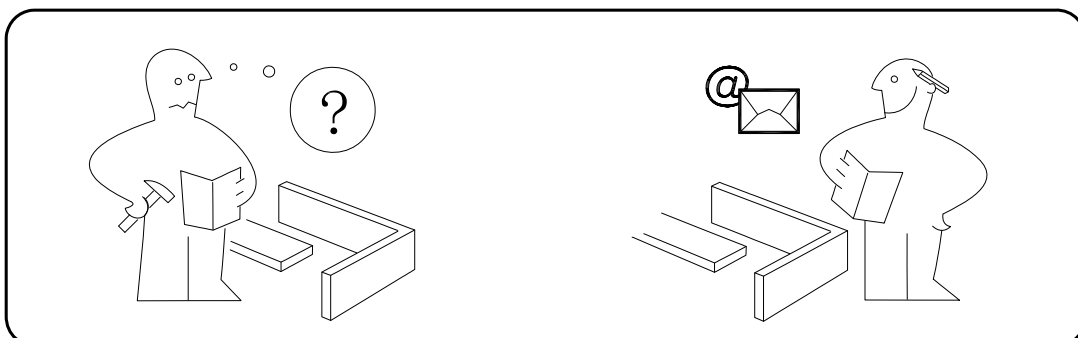
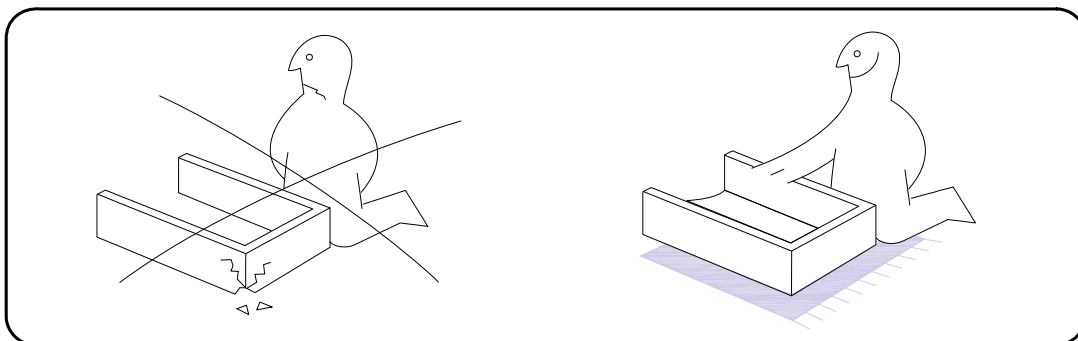
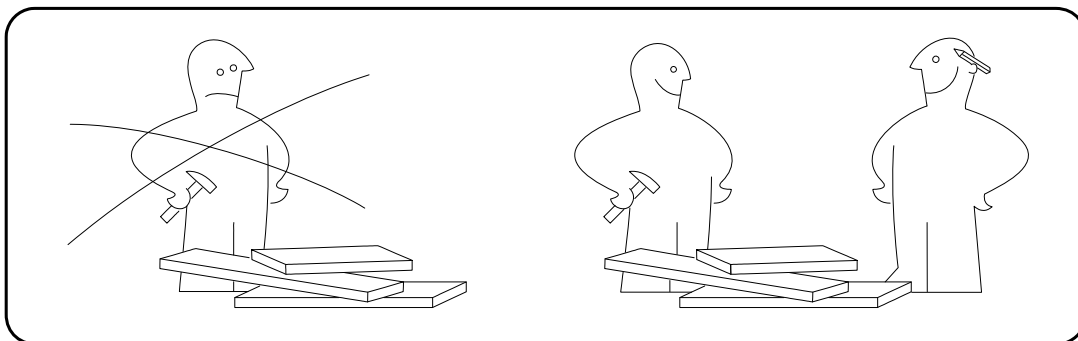
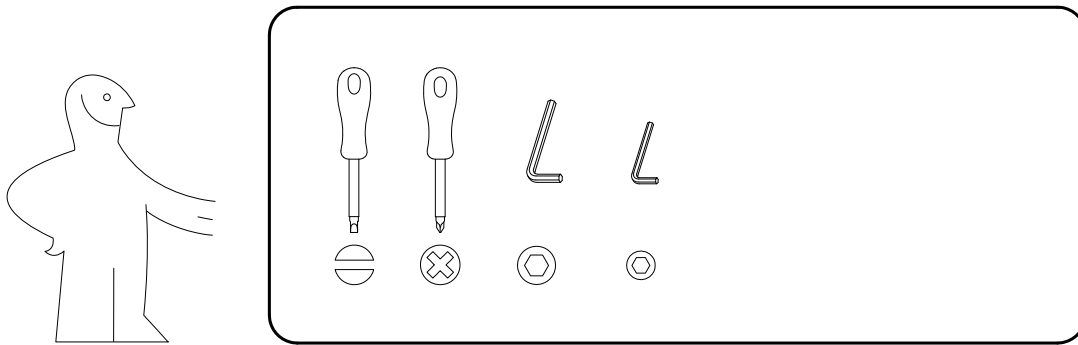





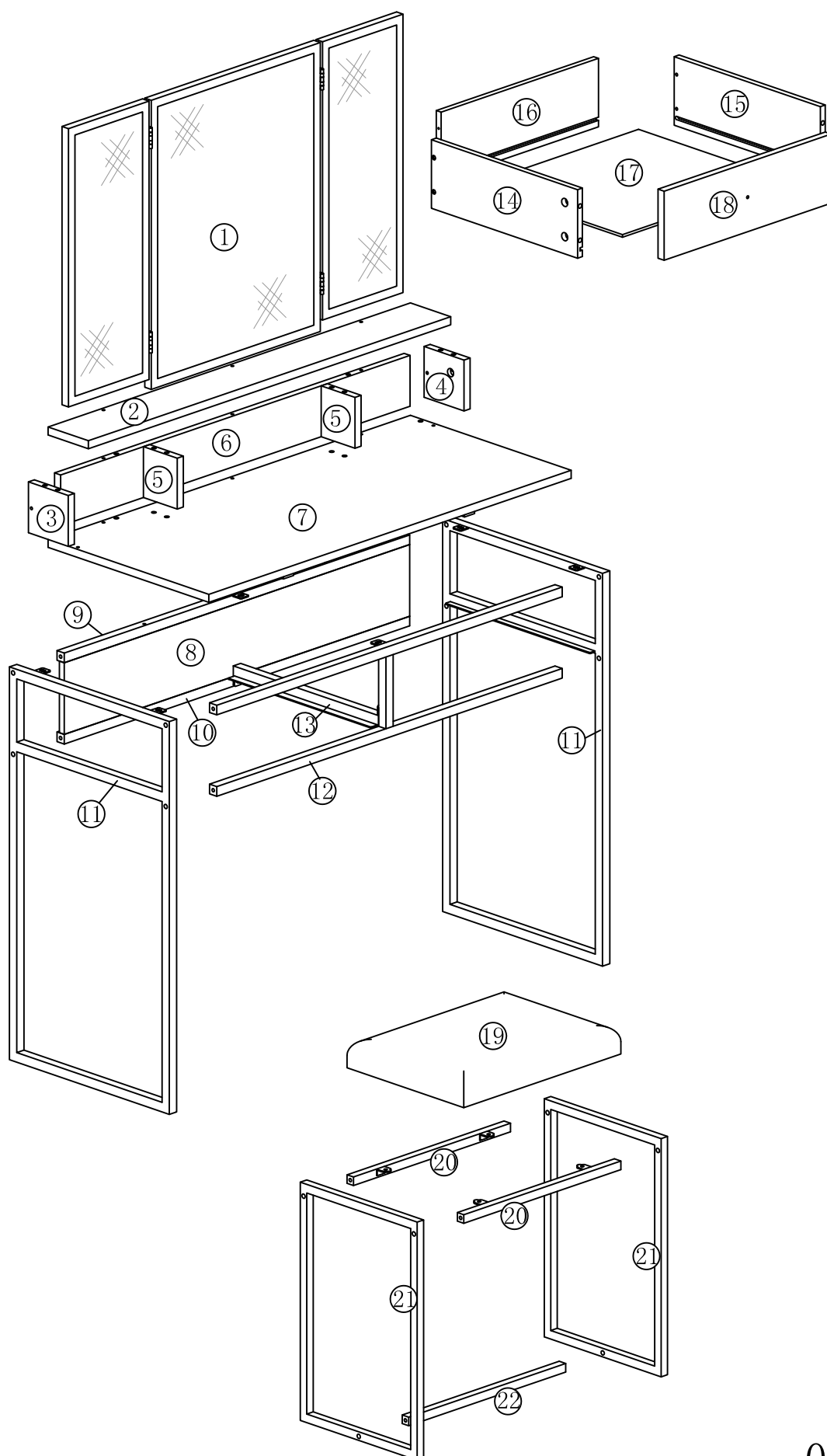



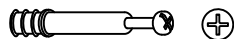

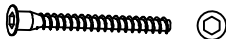



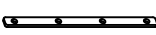

Parts List(EN)/Teileliste(DE)

No./Nr.	Qty/Menge
①	1
②	1
③	1
④	1
⑤	2
⑥	1
⑦	1
⑧	1
⑨	1
⑩	1
⑪	2
⑫	1
⑬	1
⑭	2
⑮	2
⑯	2
⑰	2
⑱	1
⑳	2
㉑	2
㉒	1



Parts List(EN)/Teileliste(DE)

No./Nr.	Picture/Bilder	Size/Größe	Qty/Menge
A	 ⊕	∅7*40	10
B		∅15*9.5	10
C		∅8*30	16
D	 ⊙	∅7*48	14
E	 ⊕	#8*35	8
F		63*16	2
G	 ⊕	#3*15	4
H	 ⊕	M6*28	8
I	 ⊕	M6*12	17
J		∅20*21	2
K	 ⊕	M4*20	2
L		220*15*4	2
	 ⊕	4mm	1
	 ⊕	3mm	1
	 ⊕		1
			1
STOOL ASSEMBLY HARDWARE PACK			
M	 ⊕	M6*28	6
N	 ⊕	#3.5*12	4

STEP/SCHRITT 1

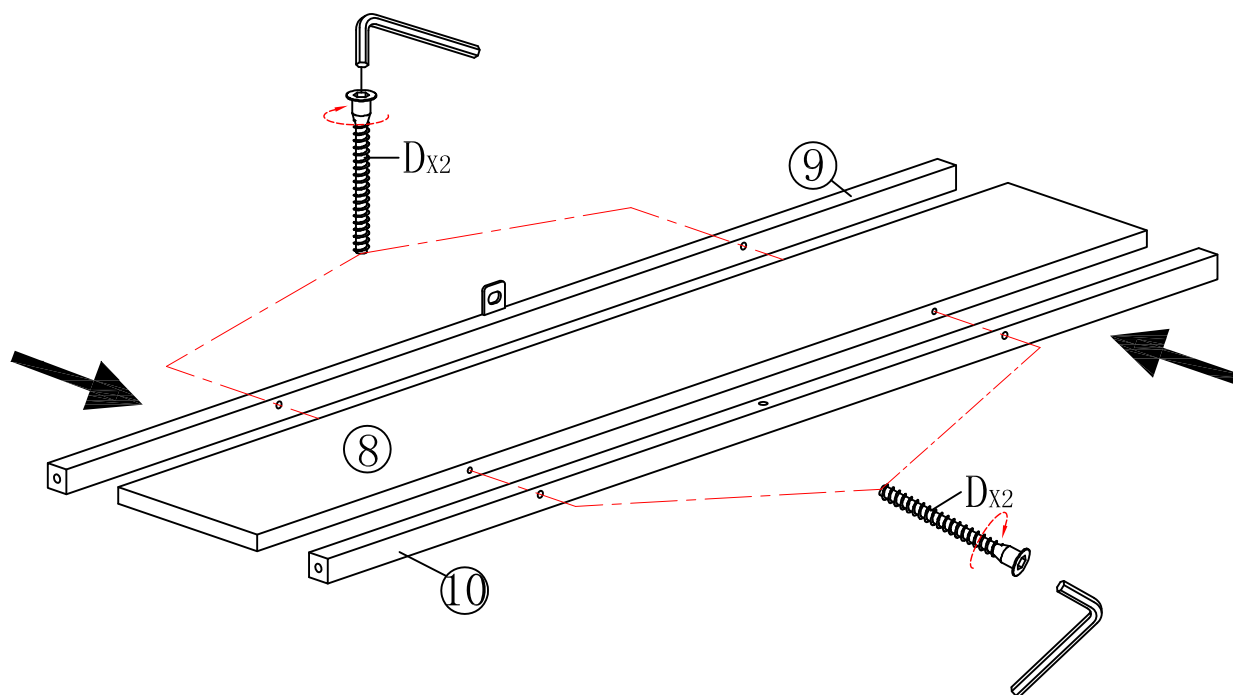

STEP/SCHRITT 2

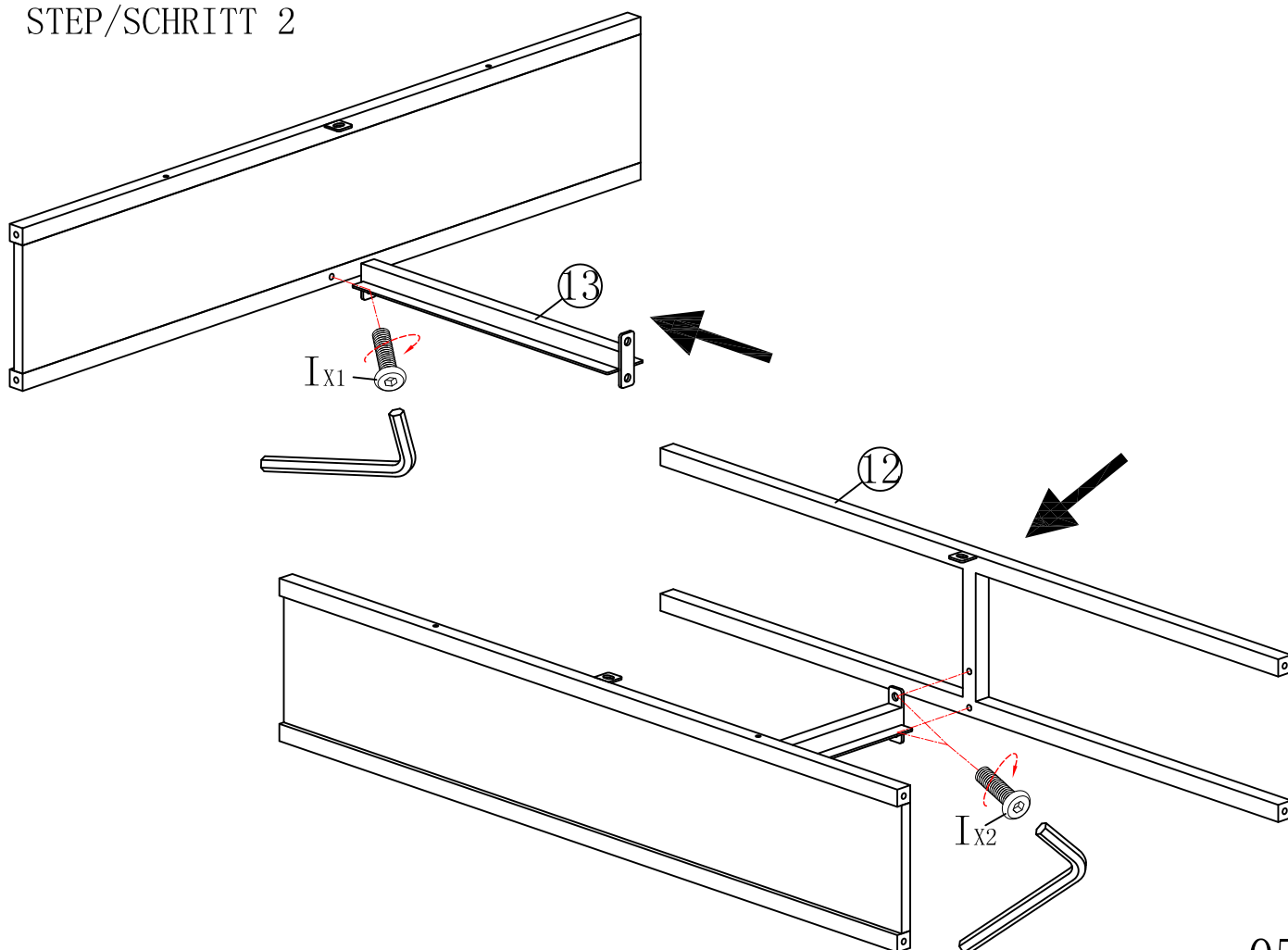

STEP/SCHRITT 3

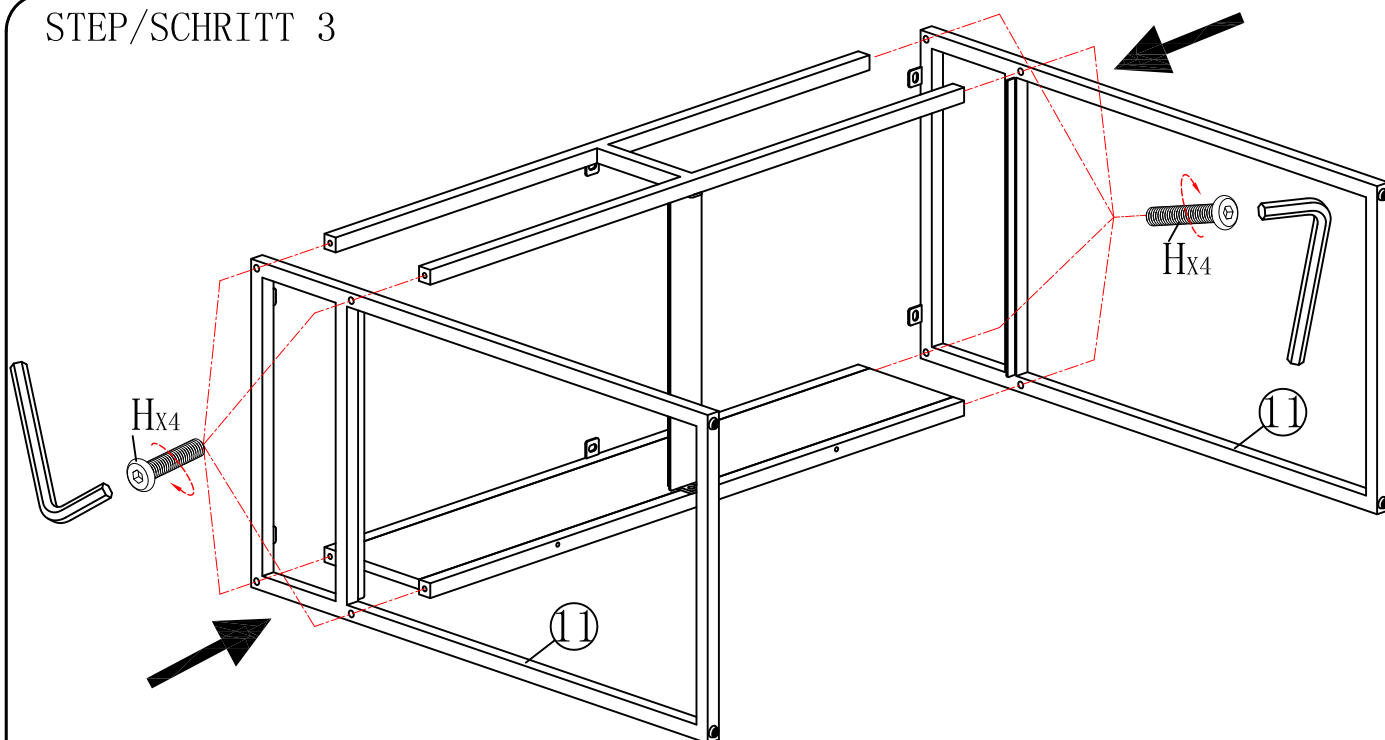

STEP/SCHRITT 4

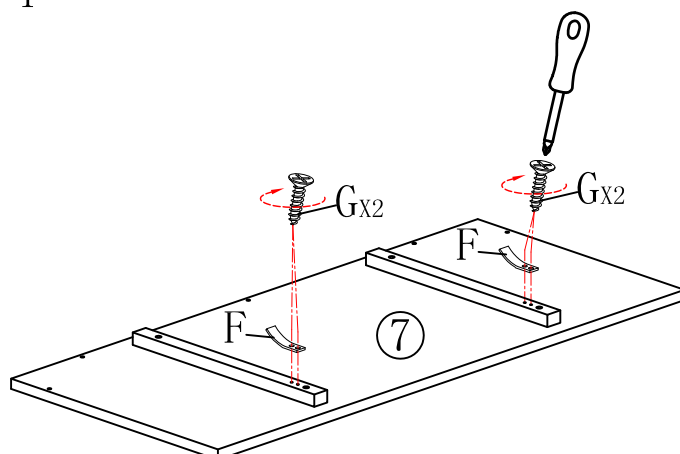

STEP/SCHRITT 5

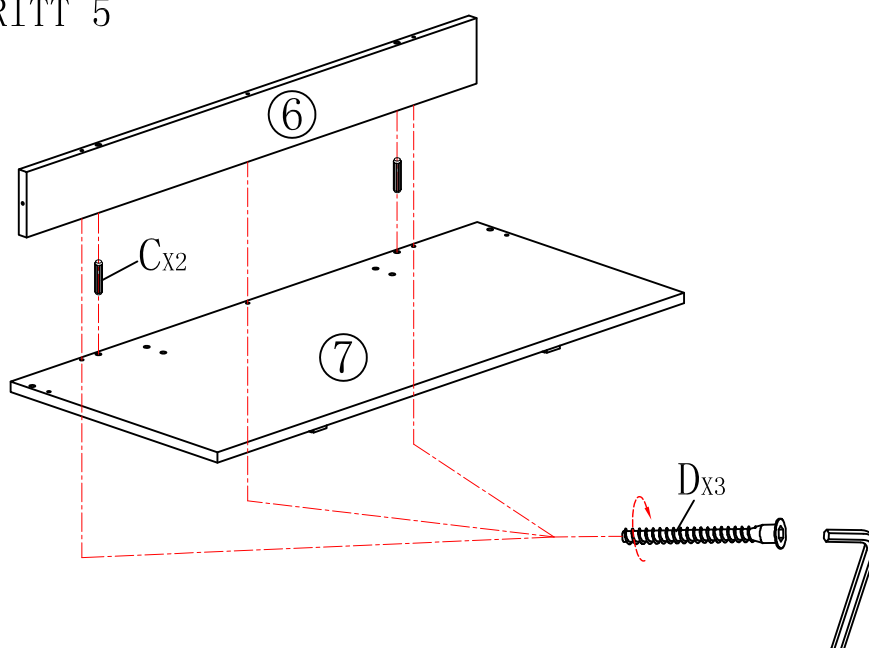

STEP/SCHRITT 6

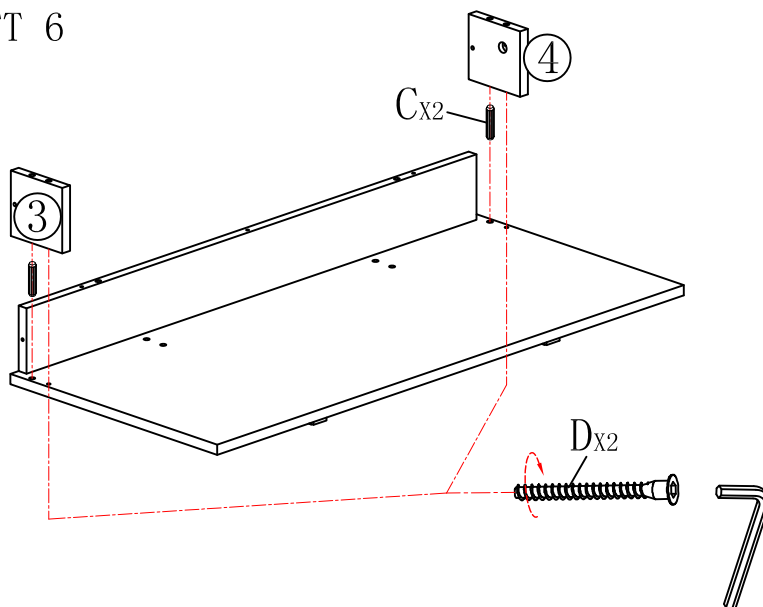

STEP/SCHRITT 7

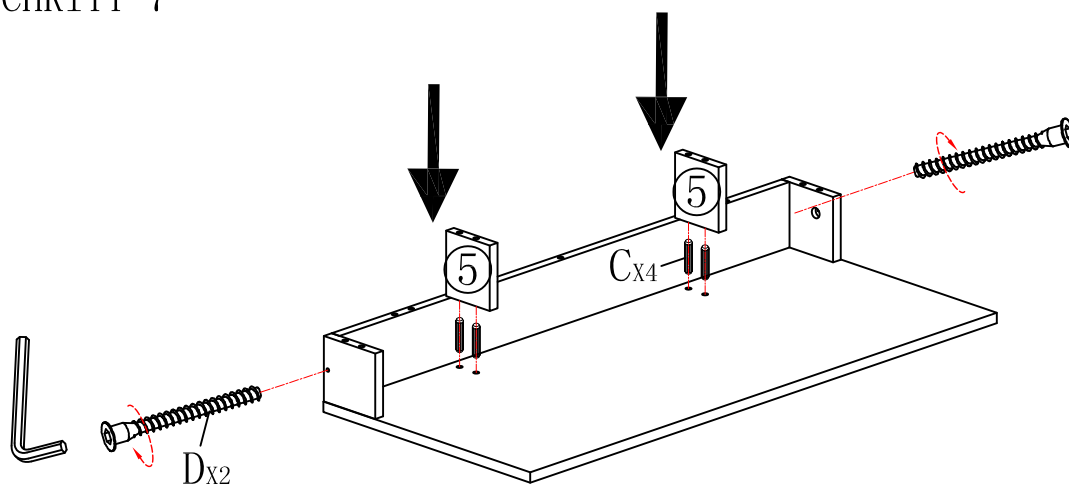

STEP/SCHRITT 8

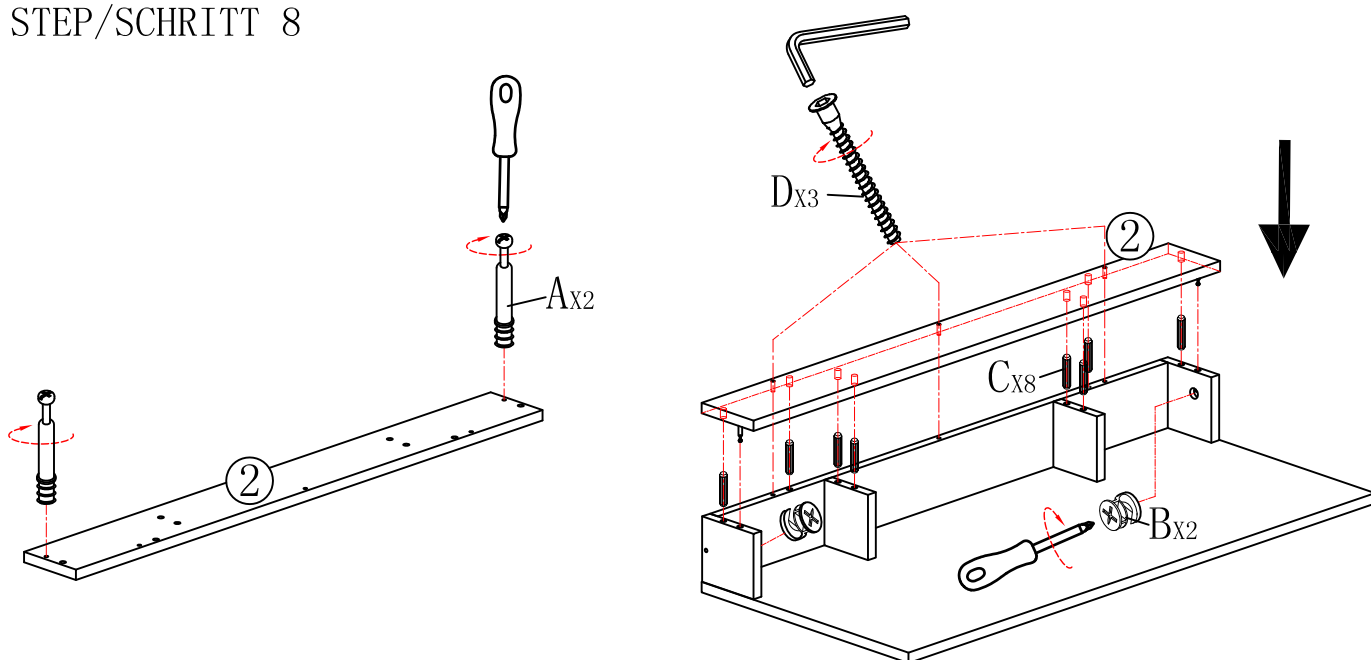

STEP/SCHRITT 9

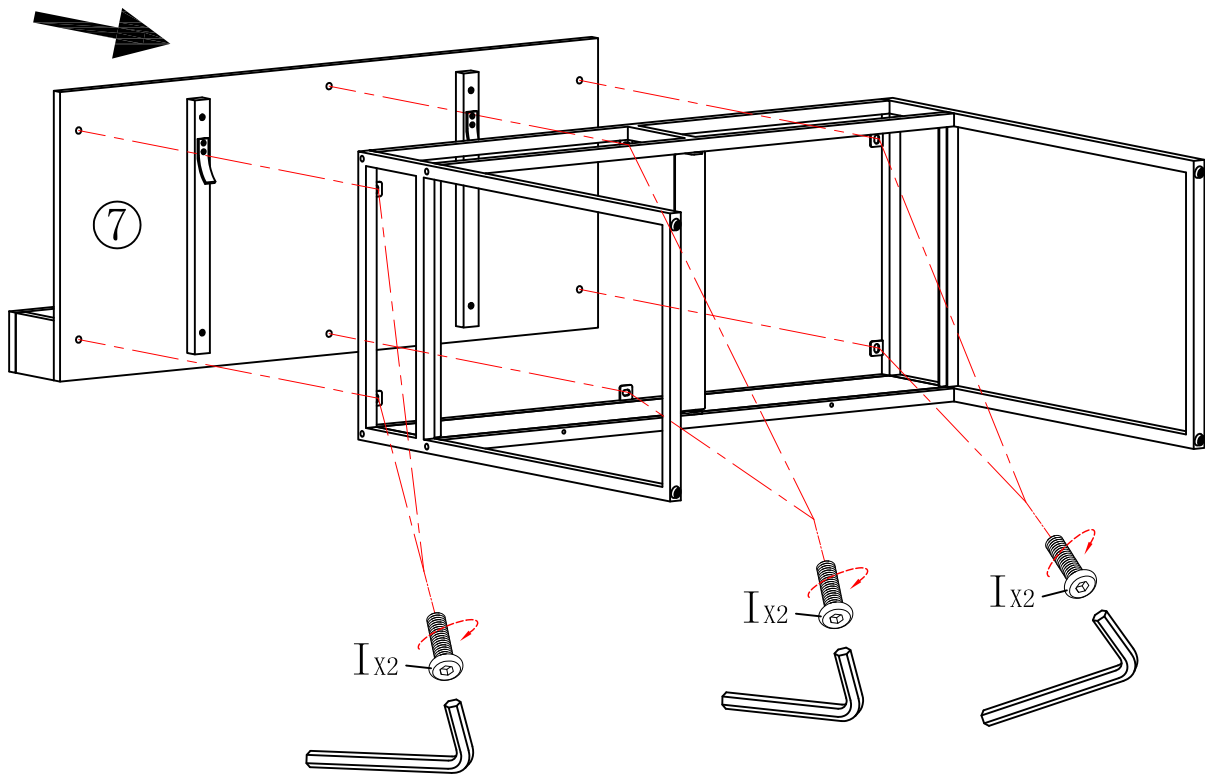

STEP/SCHRITT 10

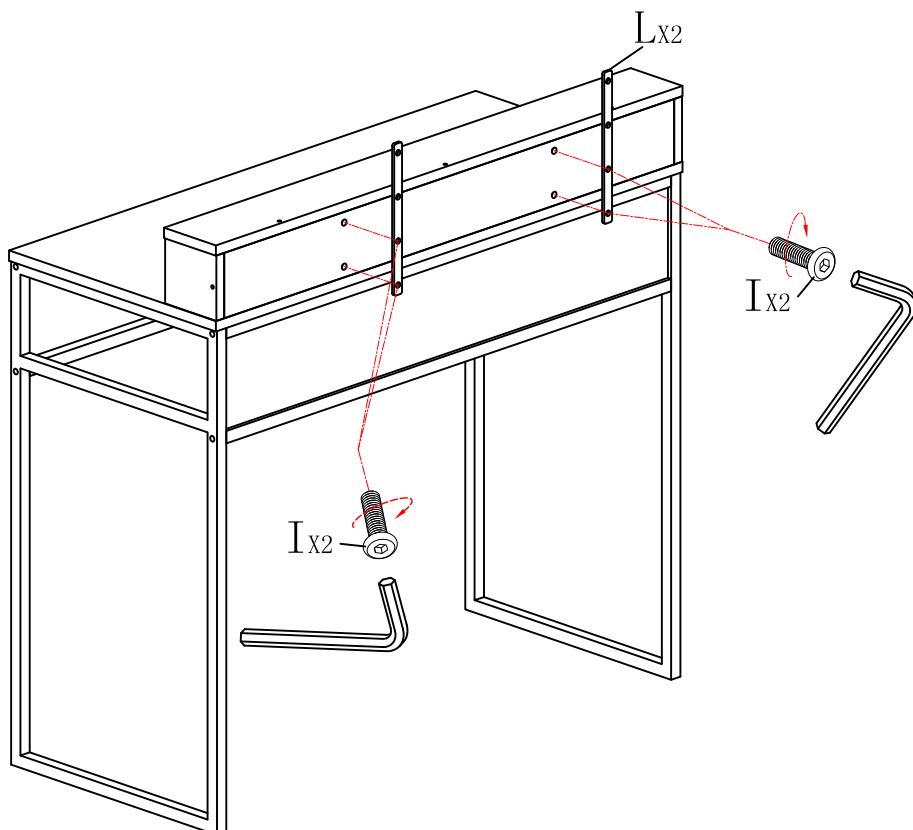

STEP/SCHRITT 11

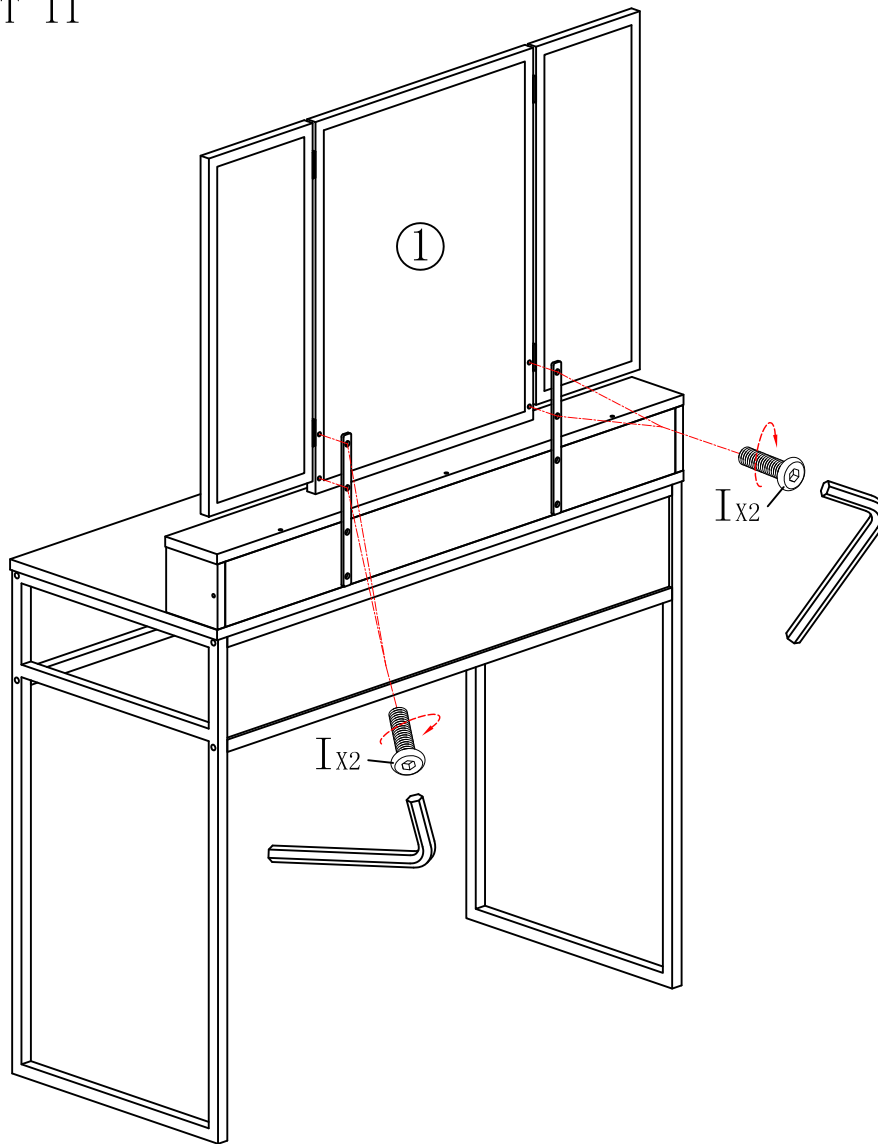

STEP/SCHRITT 12

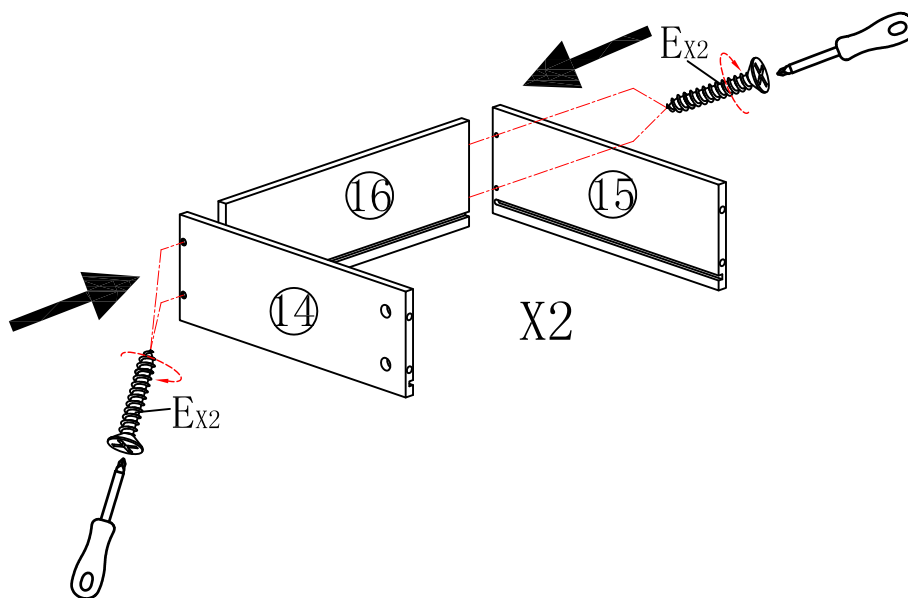

STEP/SCHRITT 13

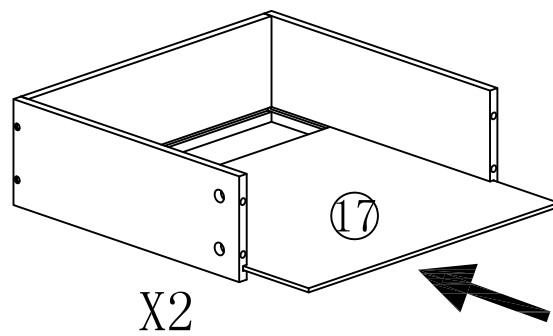

STEP/SCHRITT 14

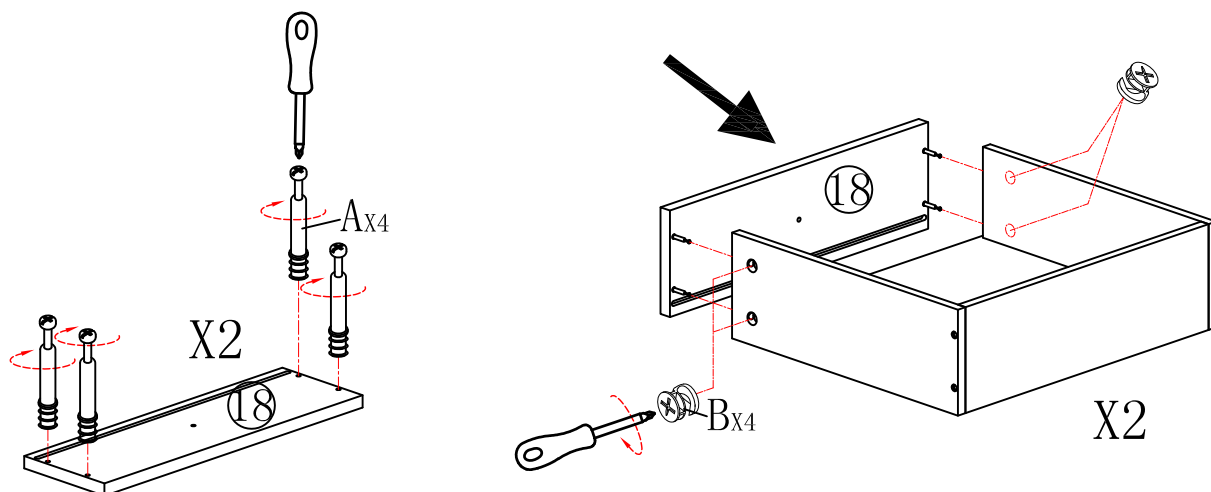

STEP/SCHRITT 15

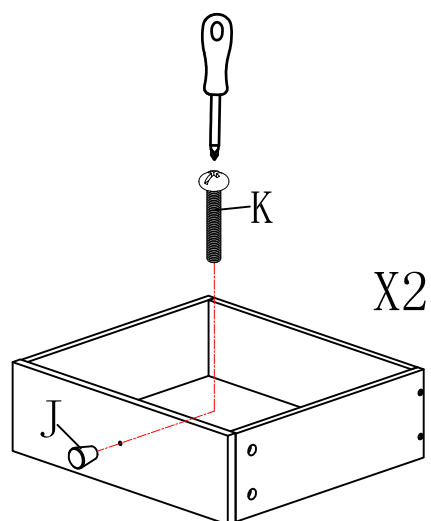

STEP/SCHRITT 16

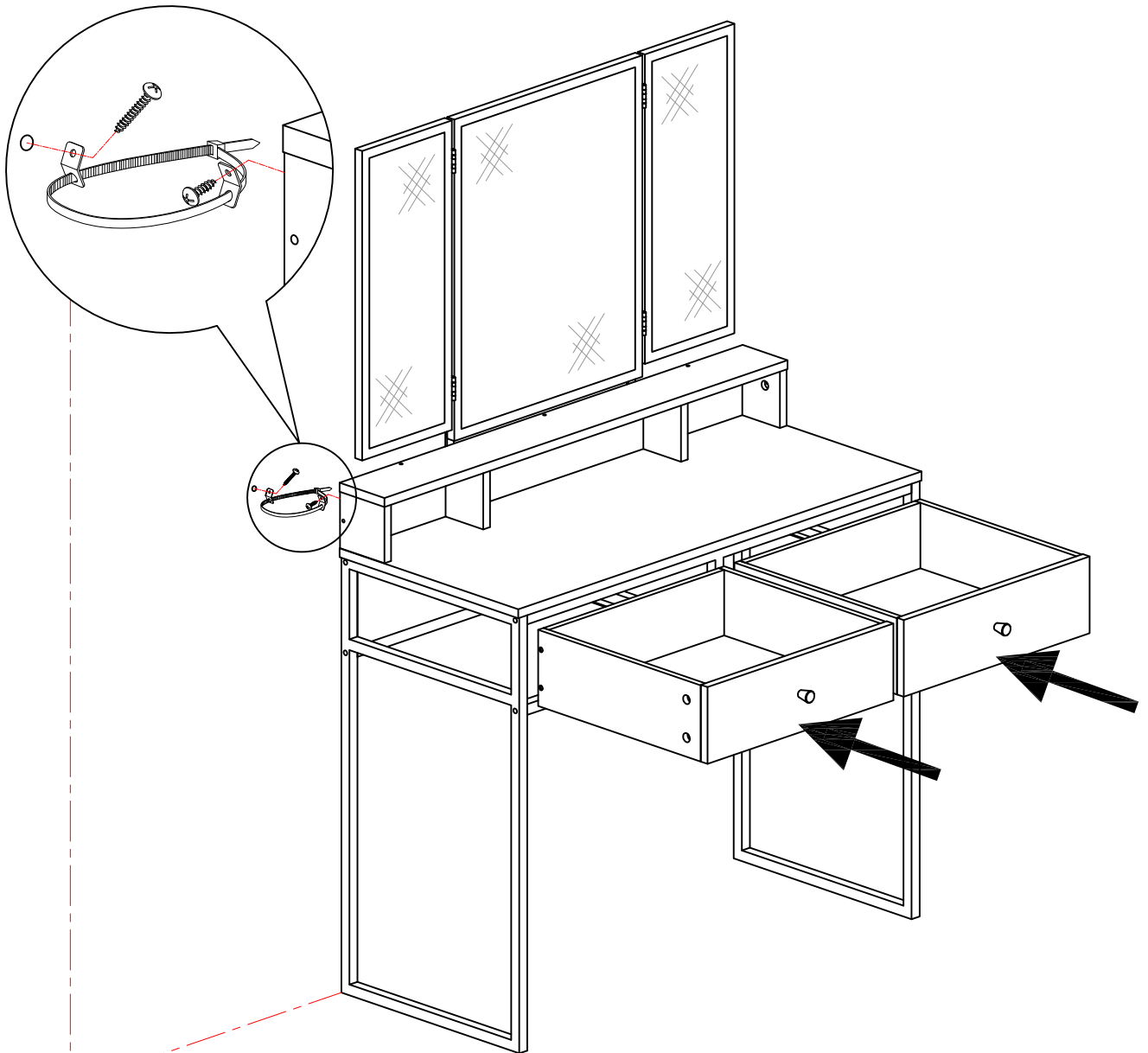

STEP/SCHRITT 17

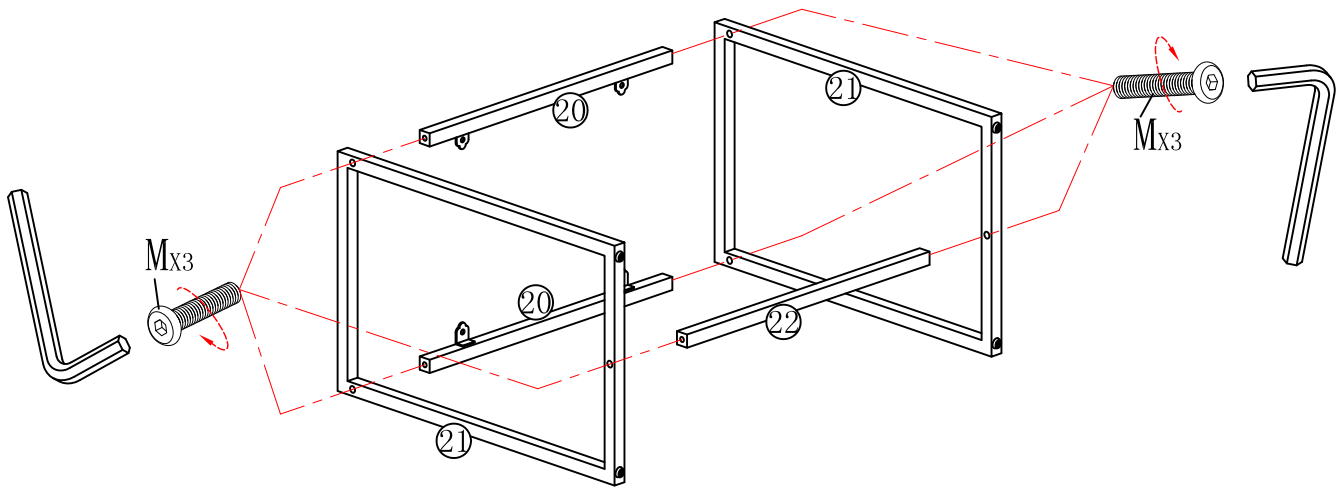

STEP/SCHRITT 18

