

ASSEMBLY INSTRUCTIONS
20 INCHES BATH VANITY (COMBO)

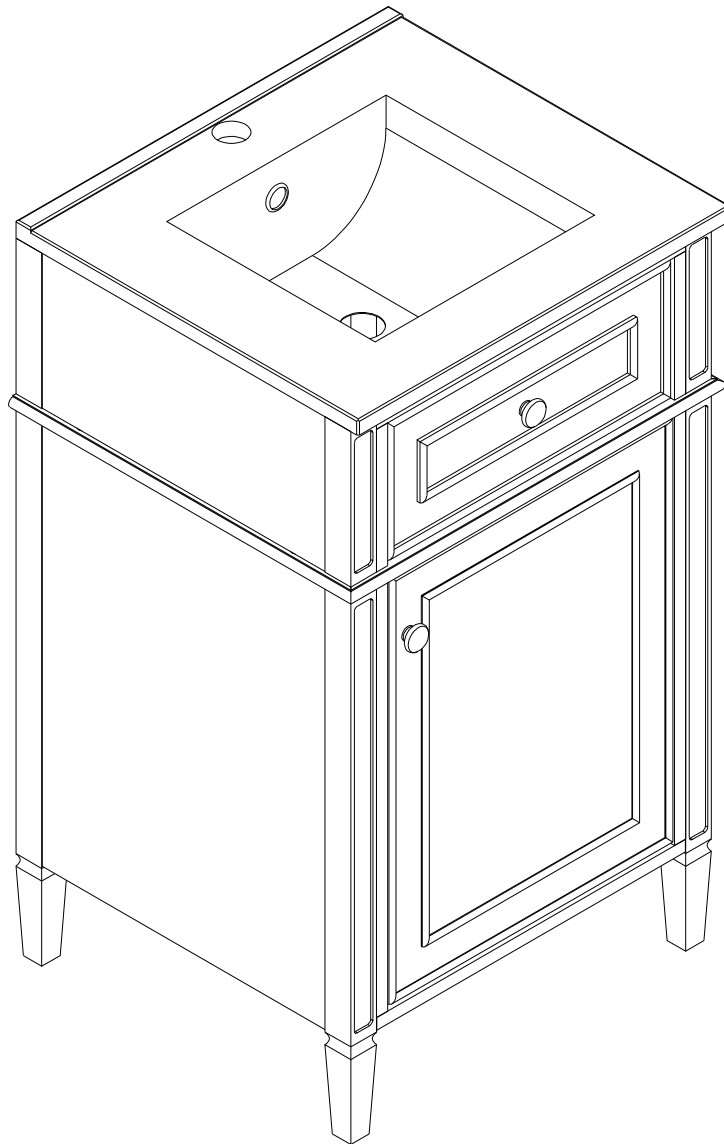

Thank you for purchasing this quality product. Be sure to check all packaging material carefully for small parts which may have come loose inside the carton during shipment. Separate, identify and count all parts and hardware. Compare with the parts list to be sure all parts are present.
"DO NOT TIGHTEN SCREWS UNTIL COMPLETELY ASSEMBLED"

*** Use of power tool to assemble this product will invalidate any claim and damage this product making unsafe !!!**
*** Please assemble on a clean soft surface to avoid damage.**

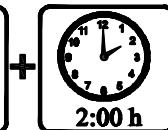
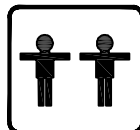

Tools Required

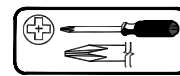

(Not included)

IMPORTANT:

PLEASE READ INSTRUCTION BEFORE STARTING THE ASSEMBLY

Before Installation



Important - Please read these instructions fully before starting assembly

Thank you for purchasing this quality product. Be sure to check all packing materials carefully for small parts, which may have come loose inside the carton during shipment. Identify and count all items according to the PARTS LIST and/or HARDWARE LIST shown below. Check you have all the components and tools listed on the following pages.

- We recommend that you assemble this product with the assistance of another person; this will make the assembly easier, and will help eliminate damage to the product or injury to persons during assembly.
- Please do not over tighten screws or bolts until the assembly is completed.
- Keep children and animal away from the work area, small parts could choke if swallowed.
- Please put all parts on a non-abrasive floor before assembly, and follow the assembly steps to assemble your newly purchased product correctly and efficiently.

If you find that you have any trouble with assembly or missing or damaged parts please contact the seller.

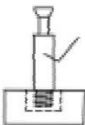
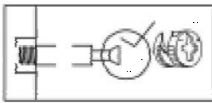
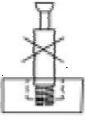
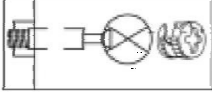
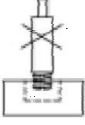
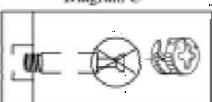

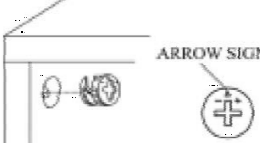
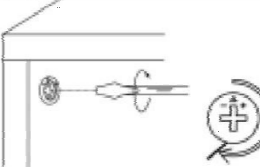



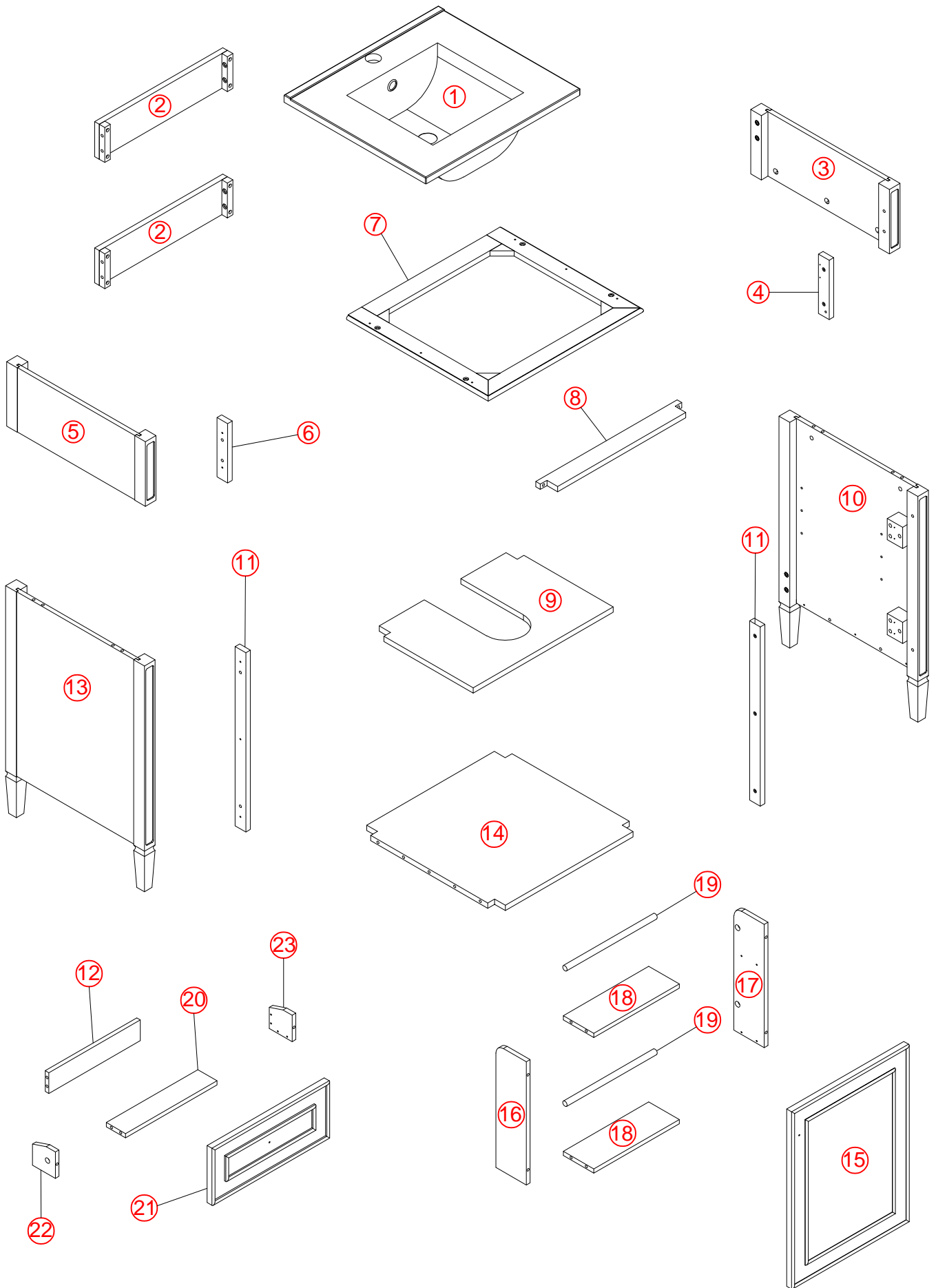

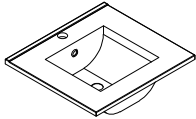
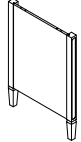
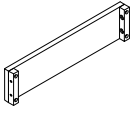
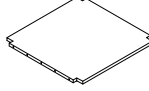
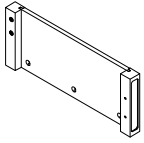
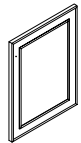

Cam Lock Assembly Instructions

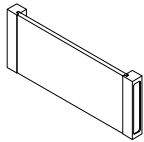
		Diagram A Insert Cam Bolt into hole as shown in diagram A.
		Diagram B Make sure not to insert the Cam Bolt: Too deep as shown in figure B as this will cause the Cam Lock to be misaligned and unable to interlock properly.
		Diagram C Also avoid inserting the Cam Bolt too close to the surface of the hole as shown in figure C, as this will cause the Cam Lock to be too loose, and not interlock properly.
		Connect the panels together.
		ARROW SIGN Insert the Cam Lock so the side opening fits over the head of the Cam Bolt.
		To tighten the Cam Lock, turn it clockwise on half a turn with a flat screwdriver. <i>*Do not use an automatic screwdriver as it may bend or break if too much power is imposed.</i>

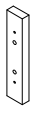
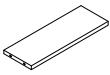
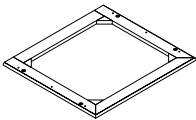

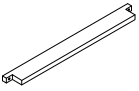
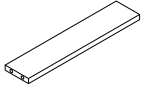
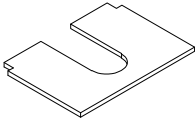
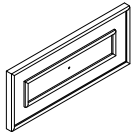
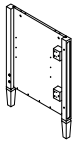







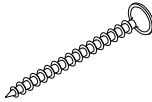



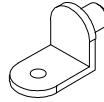

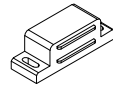
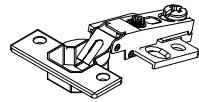

PRODUCT DETAILS

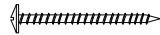

PARTS LIST

①	SINK (LAVABO)		1PC	⑬	LOWER LEFT HIP		1PC
②	REAR CROSSBAR		2PCS	⑭	BOTTOM BOARD		1PC
③	UPPER RIGHT HIP		1PC	⑮	DOOR BOARD		1PC
④	SIDE BAR UPPER RIGHT		1PC	⑯	LEFT SIDE DOOR SHELF		1PC
⑤	UPPER LEFT HIP		1PC	⑰	RIGHT SIDE DOOR SHELF		1PC
⑥	SIDE BAR UPPER LEFT		1PC	⑱	SHELF DOOR BOARD		2PCS
⑦	MIDDLE FRAME		1PC	⑲	CIRCLE		2PCS
⑧	FRONT CROSSBAR		1PC	⑳	DRAWER BOTTOM		1PC
⑨	ADJUSTABLE SHELVES		1PC	㉑	DRAWER FACE		1PC
⑩	LOWER RIGHT HIP		1PC	㉒	LEFT DRAWER SIDE		1PC
⑪	LOWER SIDE BAR		2PCS	㉓	RIGHT DRAWER SIDE		1PC
⑫	DRAWER BACK		1PC				

HARDWARE LIST

A	M4*25MM		10PCS	J	L45MM		2PCS
B	Ø 8 * 30MM		16PCS	K	Ø30mm		2PCS
C	Ø5*35MM		34PCS +2	L	L15MM		6PCS
D	M6*30MM		10PCS	M	3.5*12MM		10PCS
E	L4*58MM		1PC	N	HANDLE		1PC
F	L45MM		2PCS	P	HINGES		2PCS
G	3.5*12MM		18PCS	O	    	2SET	
H	Ø15*10MM		34PCS +2				
I	M4*20MM		2PCS	Q	M6 * 45MM	 	4PCS

ASSEMBLY TOOLS REQUIRED (NOT INCLUDED)



STEP 1

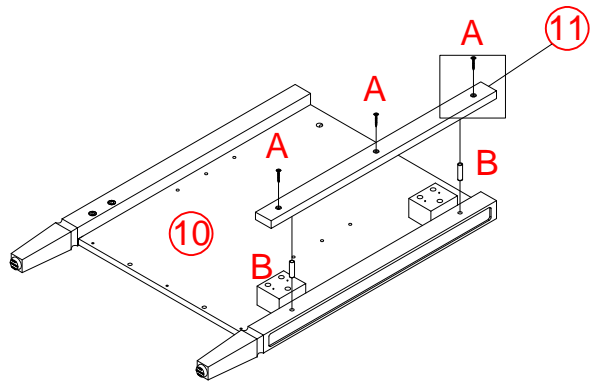
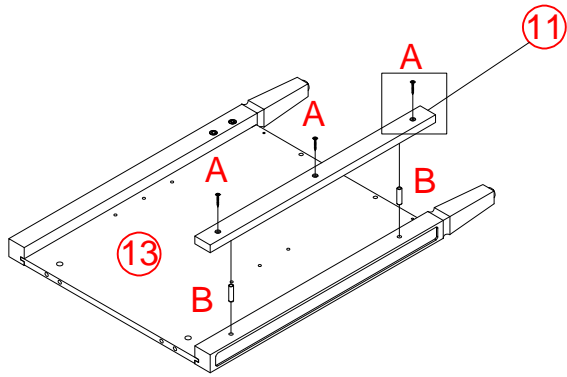
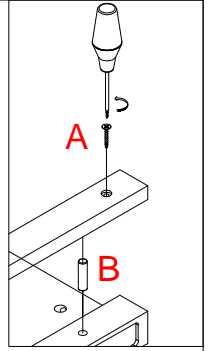

<p>(A)</p>	<p>M4*25MM</p>		<p>6PCS</p>
------------	----------------	--	-------------

<p>(B)</p>	<p>Ø 8 * 30MM</p>		<p>4PCS</p>
------------	-------------------	--	-------------

STEP 2

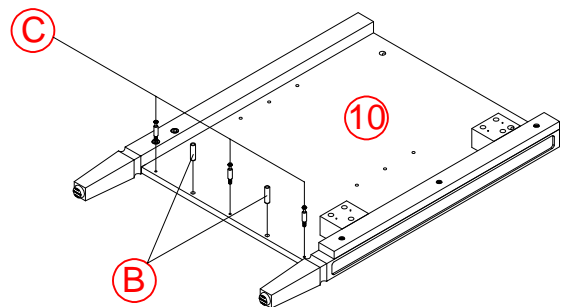
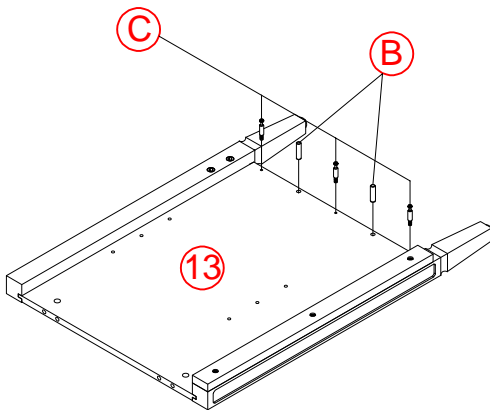
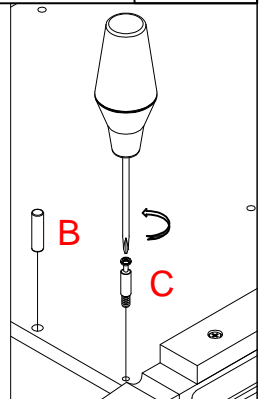

<p>(C)</p>	<p>Ø5*35MM</p>		<p>6PCS</p>
------------	----------------	--	-------------

<p>(B)</p>	<p>Ø 8 * 30MM</p>		<p>4PCS</p>
------------	-------------------	--	-------------

STEP 3

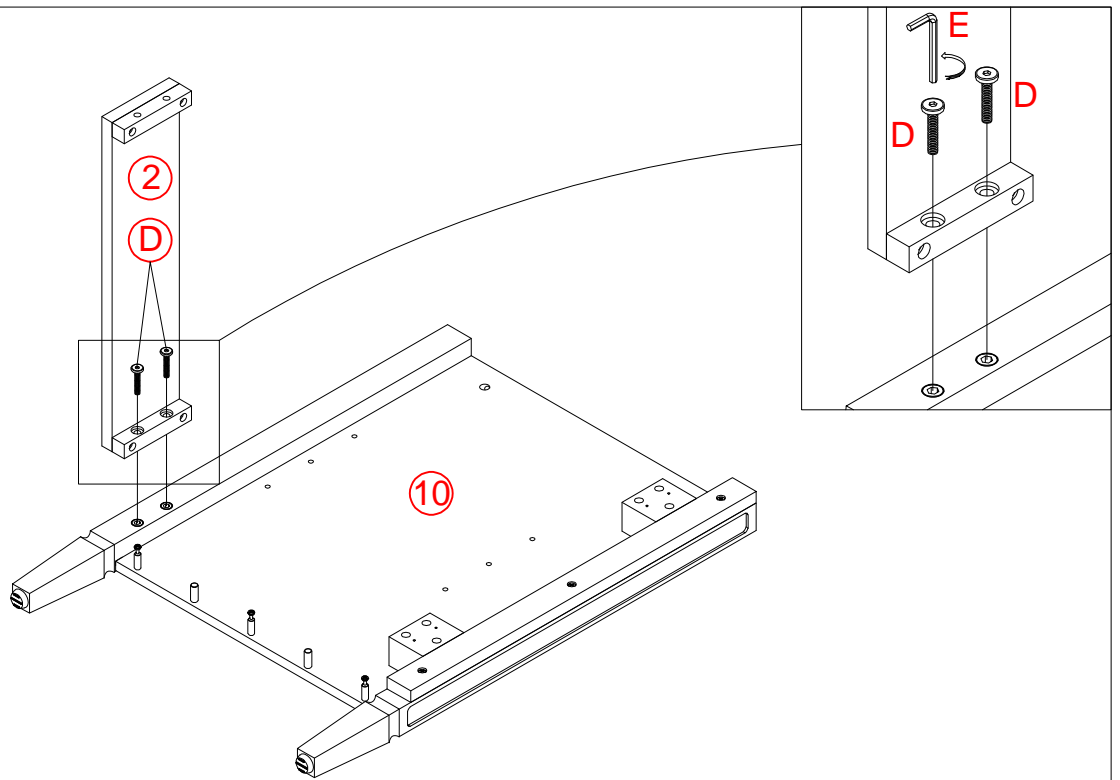

<p>Ⓓ</p>	<p>M6*30MM</p>	 <p>2PCS</p>	<p>Ⓔ</p>	<p>L4*58MM</p>	 <p>1PC</p>
----------	----------------	--	----------	----------------	---

STEP 4

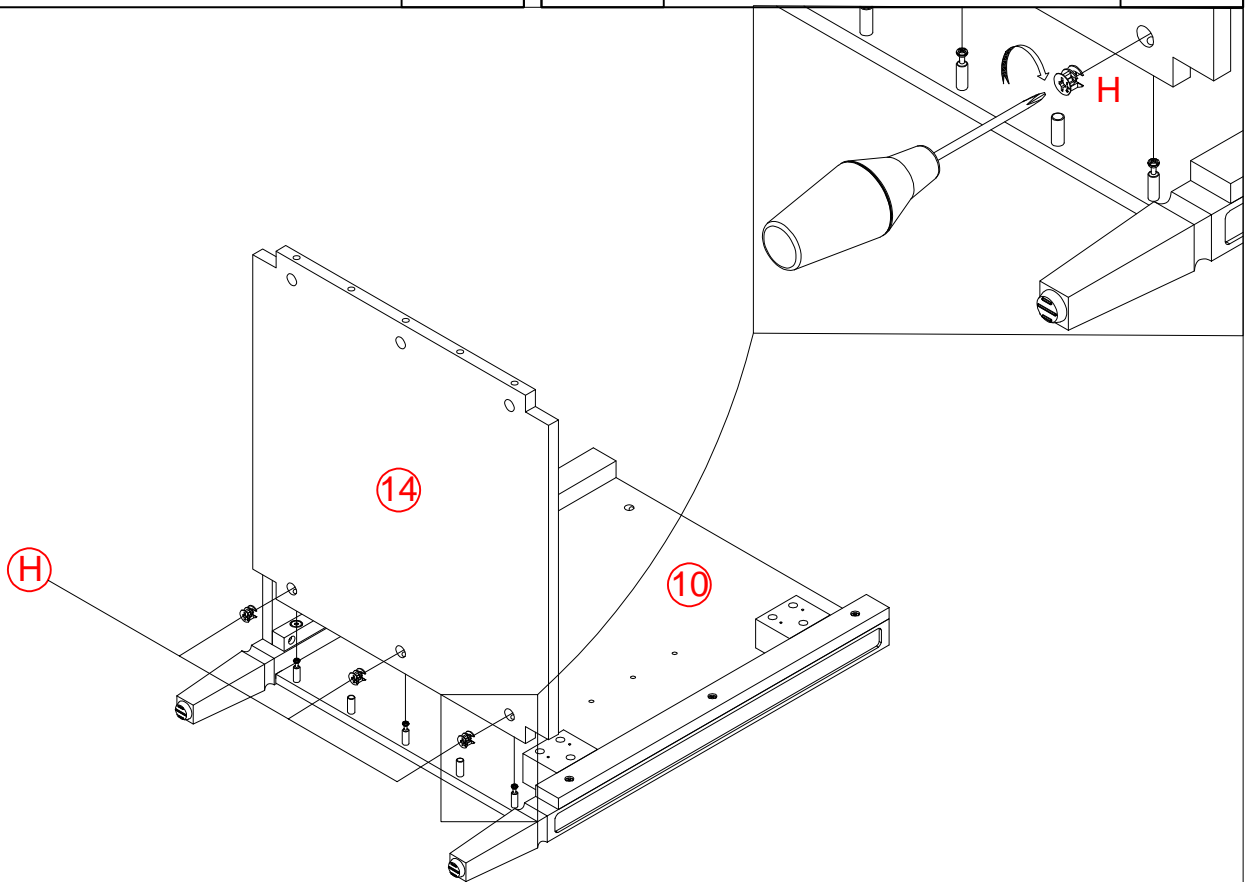

<p>Ⓕ</p>	<p>Ø15*10MM</p>	 <p>3PCS</p>
----------	-----------------	---

STEP 5

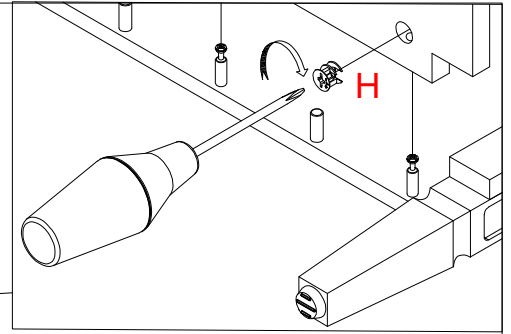
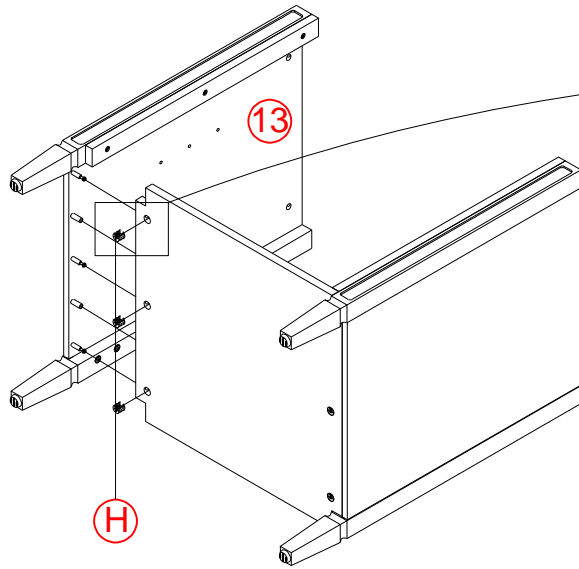

Ⓜ	Ø15*10MM		3PCS
---	----------	--	------

STEP 6

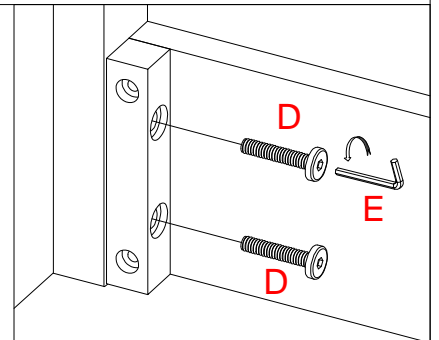
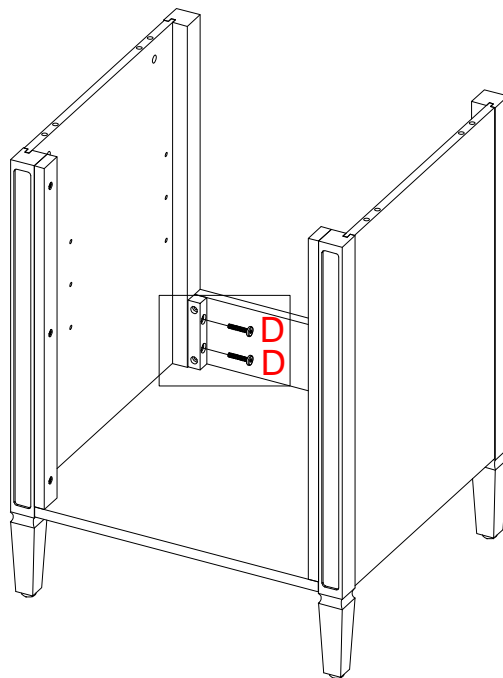

Ⓜ	M6*30MM		2PCS
---	---------	---	------

STEP 7

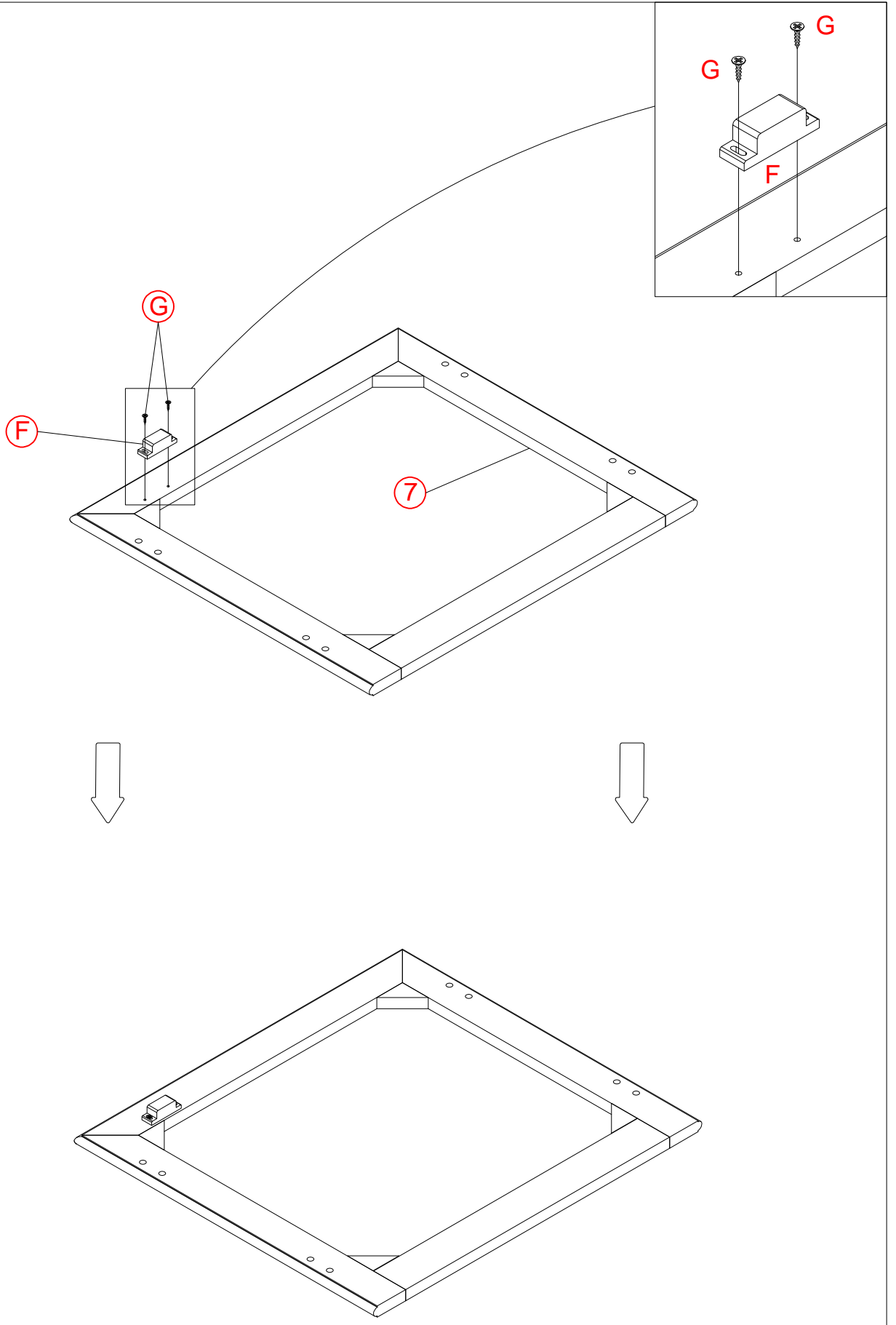

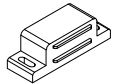
G	3.5*12MM		2PCS	F	L45MM		1PC
----------	----------	---	------	----------	-------	---	-----

STEP 8

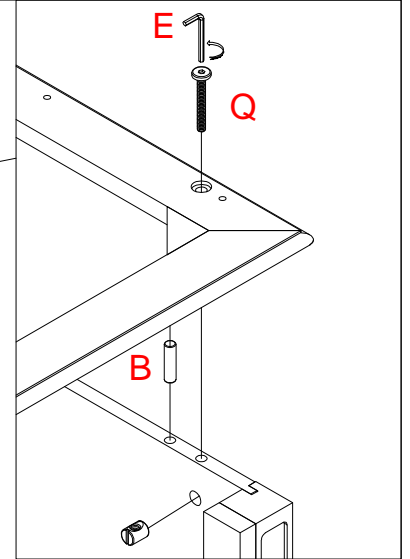
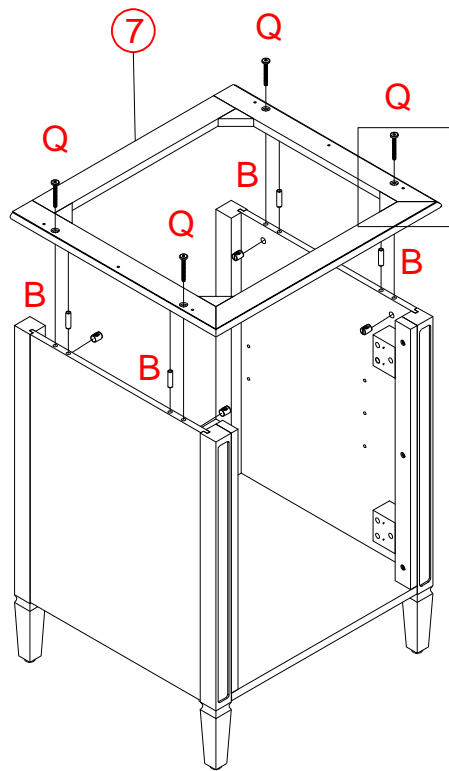

Q	M6 * 45MM		4PCS
----------	-----------	--	------

B	Ø 8 * 30MM		4PCS
----------	------------	--	------

STEP 9

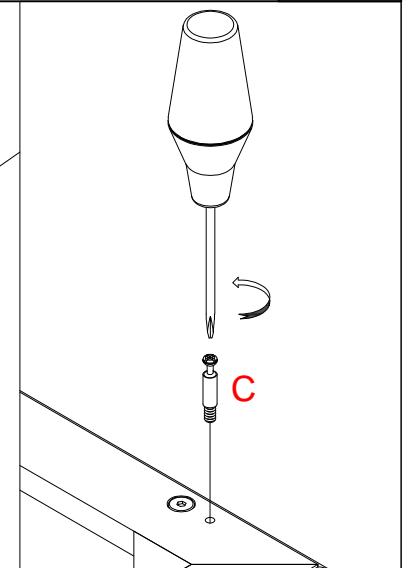
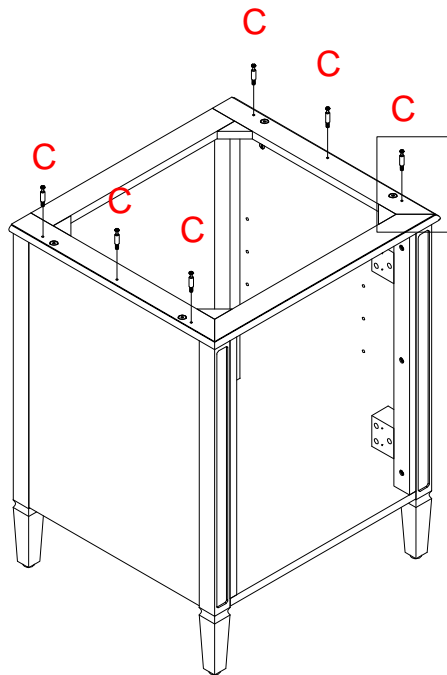

C	Ø5*35MM		6PCS
----------	---------	---	------

STEP 10

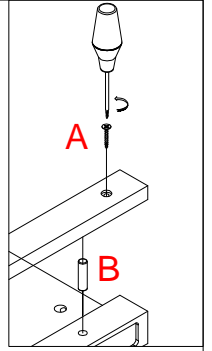
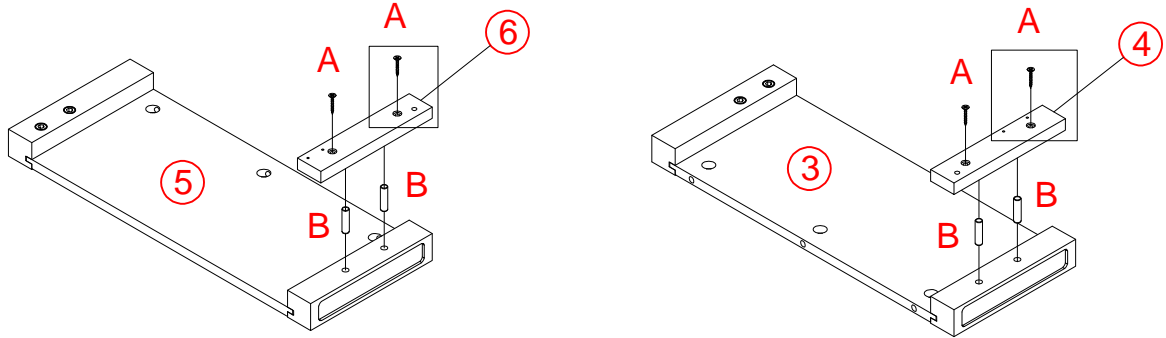

(A)	M4*25MM		4PCS
-----	---------	--	------

(B)	Ø 8 * 30MM		4PCS
-----	------------	--	------

STEP 11

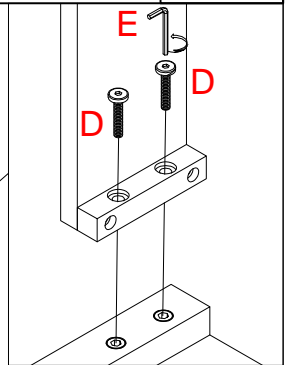
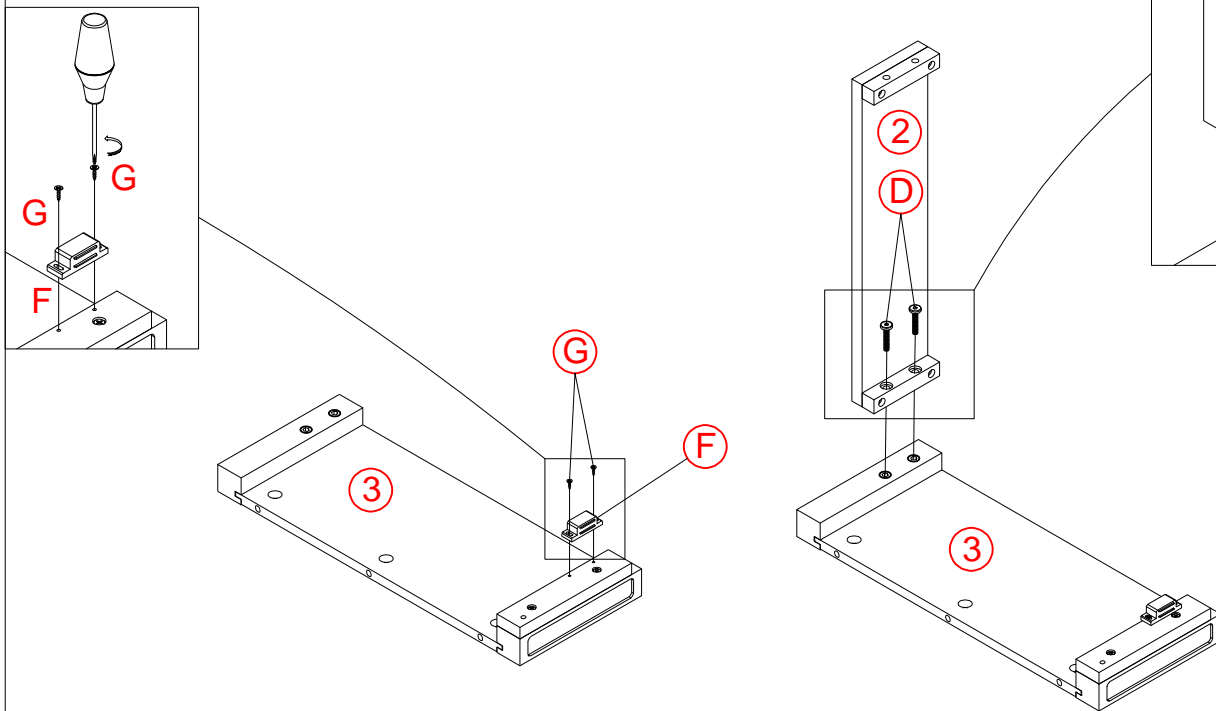

(F)	L45MM		1PC
-----	-------	---	-----

(G)	3.5*12MM		2PCS
-----	----------	---	------

(D)	M6*30MM		2PCS
-----	---------	---	------

STEP 12

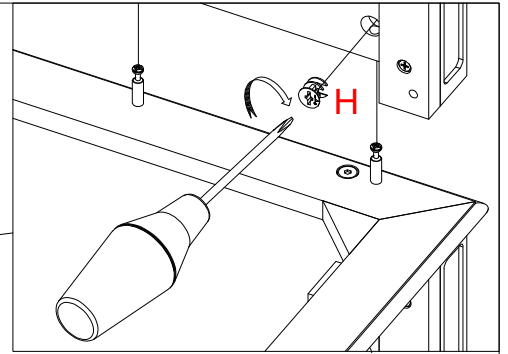
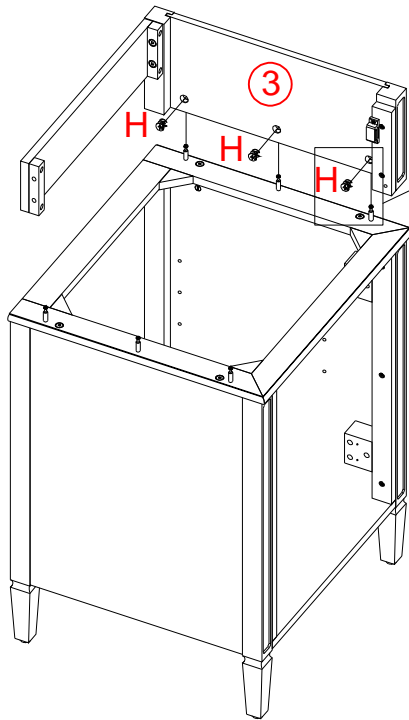

	Ø15*10MM	 3PCS
--	----------	---

STEP 13

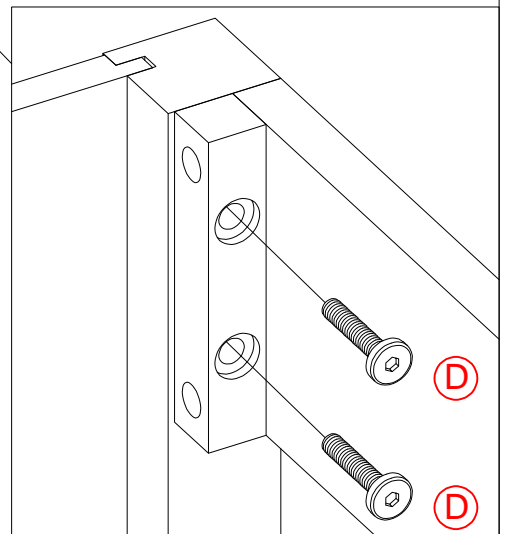
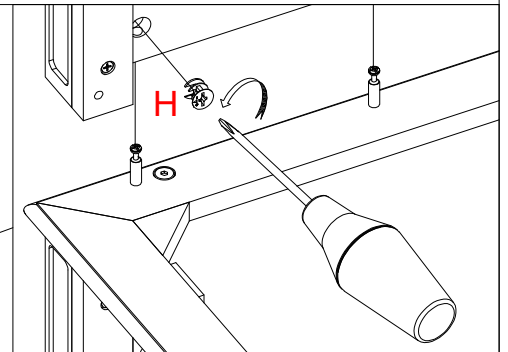
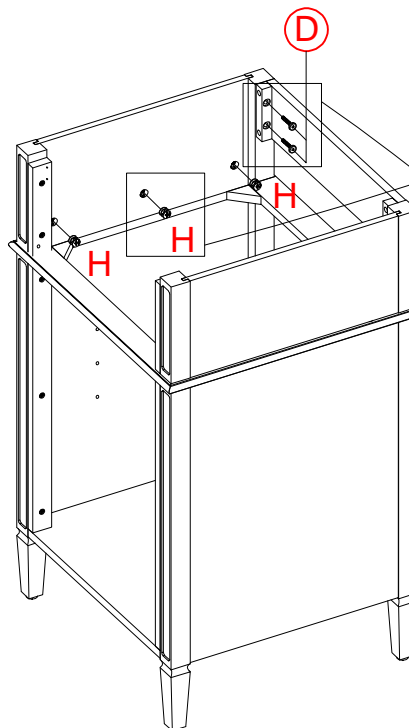

	Ø15*10MM	 3PCS		M6*30MM	 2PCS
---	----------	--	---	---------	--

STEP 14

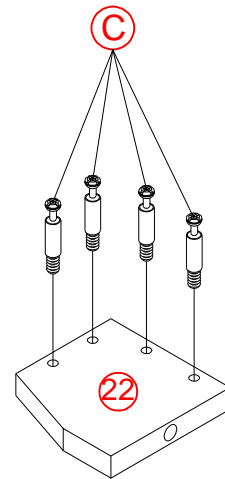
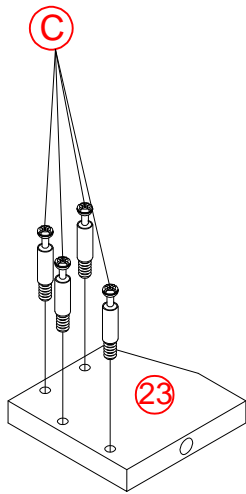

	Ø5*35MM	 8PCS
--	---------	---

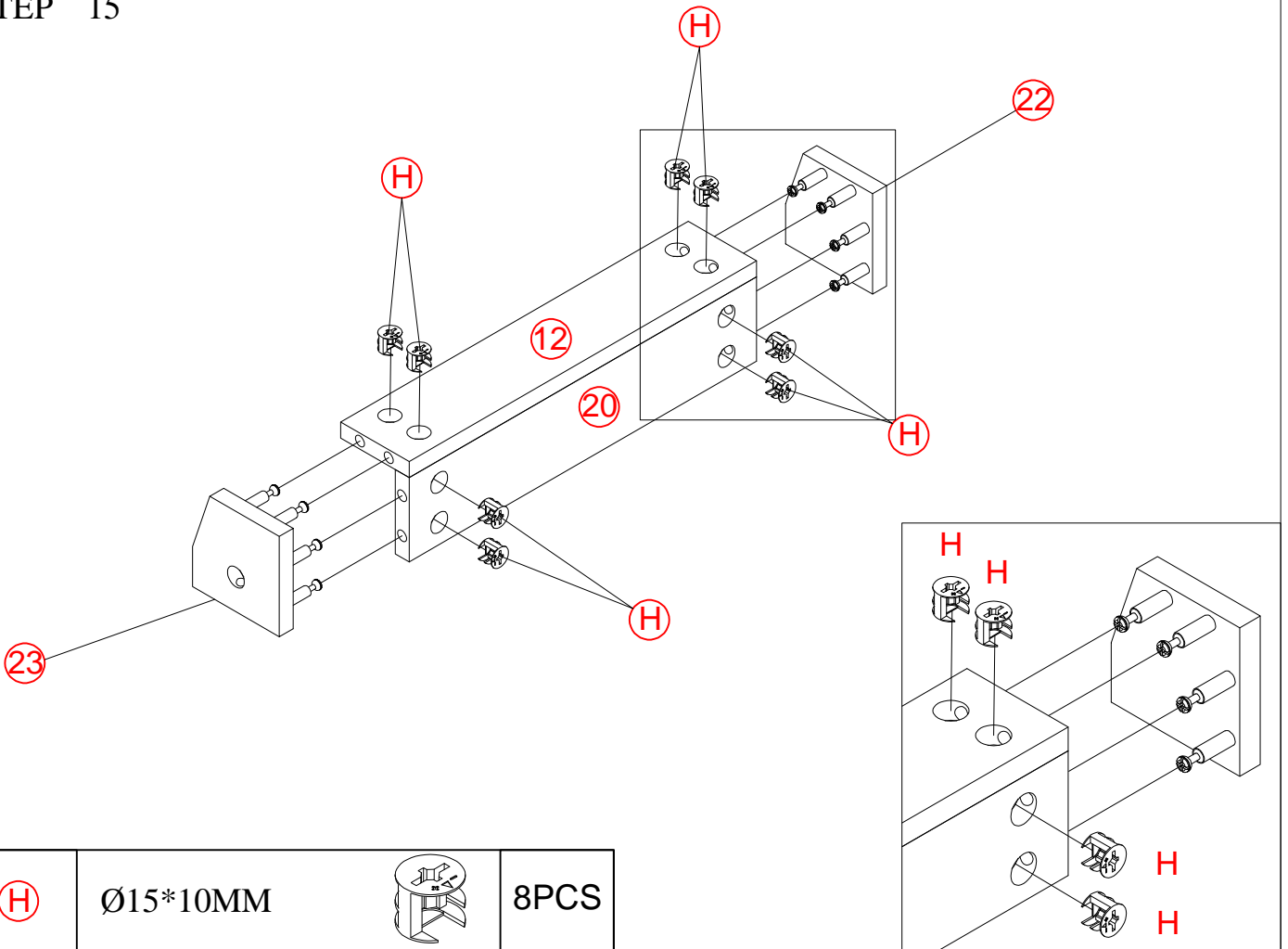

STEP 15



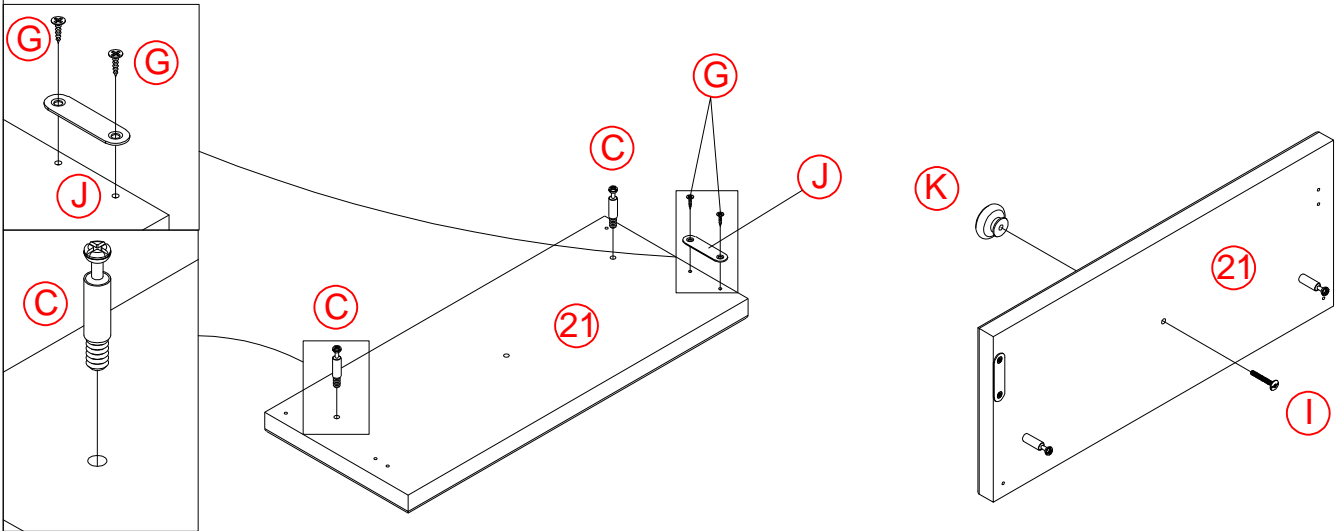

	Ø15*10MM	 8PCS
---	----------	--

STEP 16



(J)	L45MM		1PC
(C)	Ø5*35MM		2PCS

(K)	Ø30mm		1PC
(I)	M4*20MM		1PC
(G)	3.5*12MM		2PCS

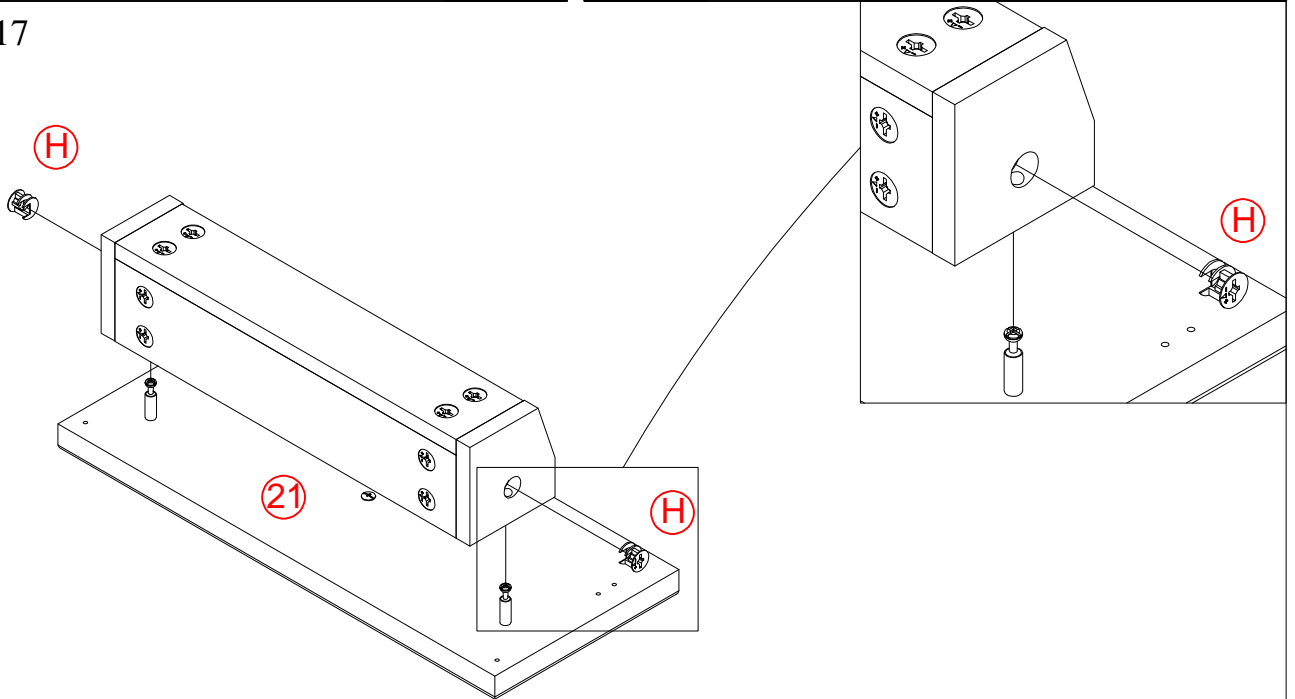

STEP 17

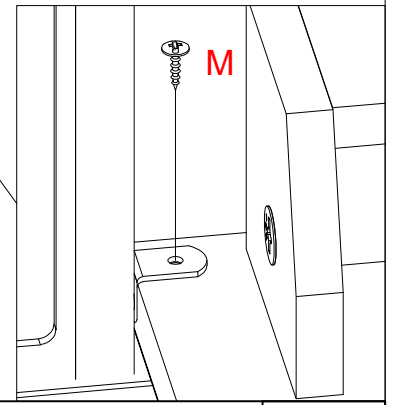
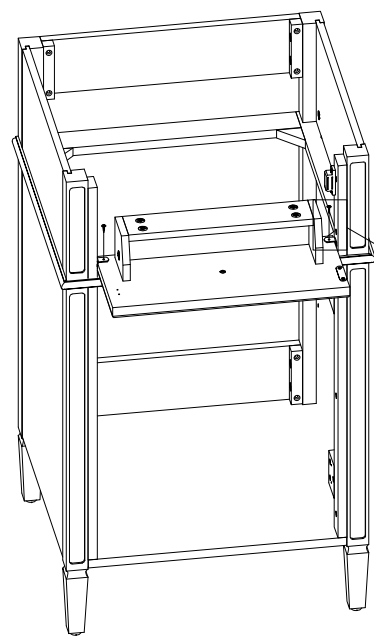
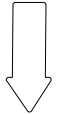
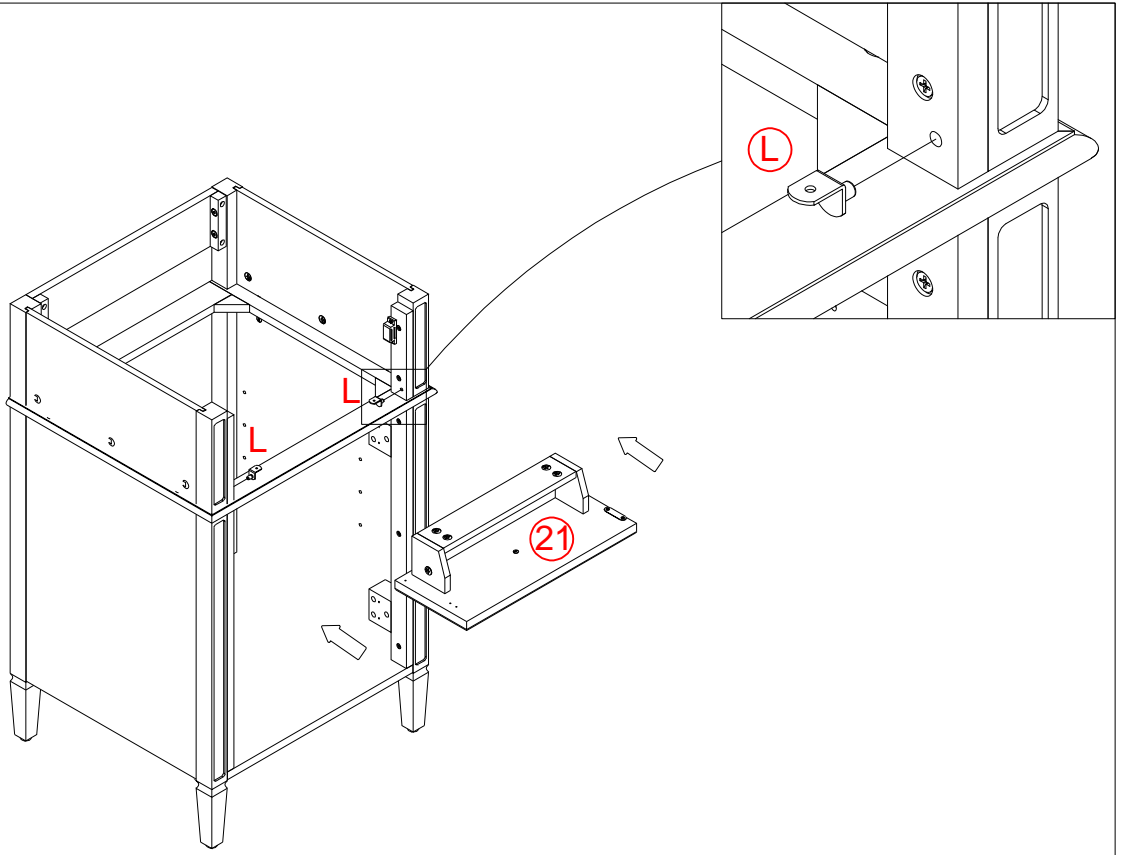

(H)	Ø15*10MM		2PCS
-----	----------	---	------

STEP 18

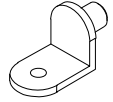

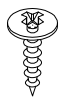
	L15MM		2PCS		3.5*12MM		2PCS
---	-------	---	------	---	----------	---	------

STEP 19

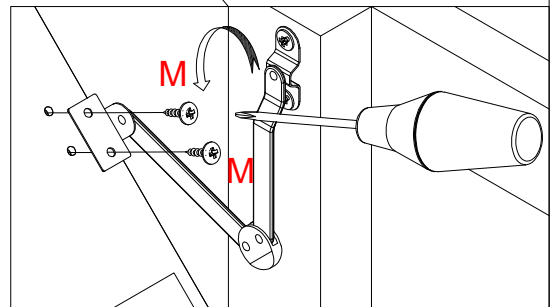
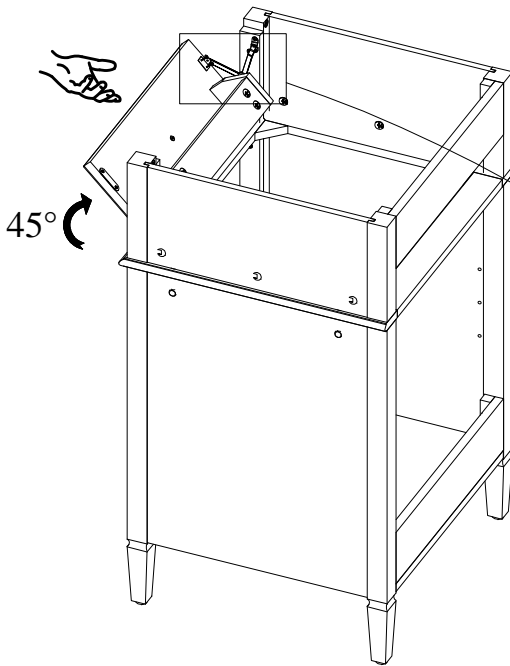
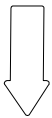
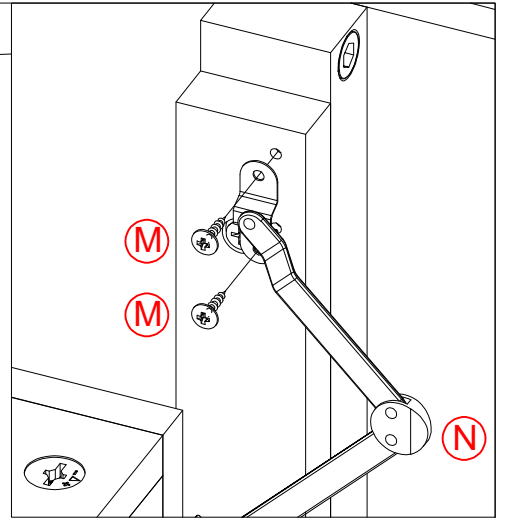
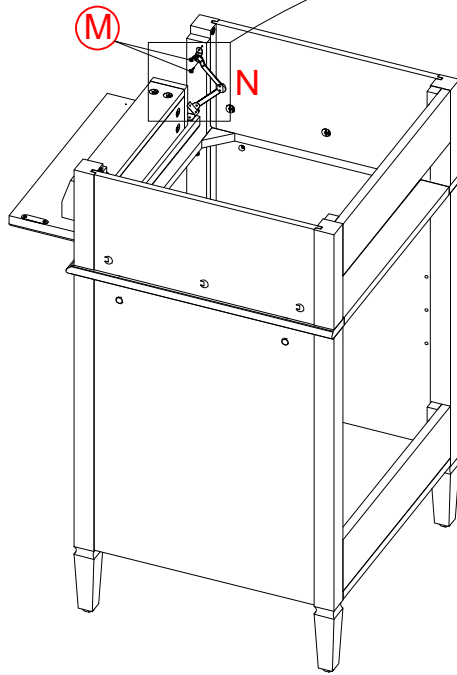

	<p>HANDLE</p> 	<p>1PCS</p>		<p>3.5*12MM</p>	 <p>4PCS</p>
---	---	-------------	---	-----------------	---

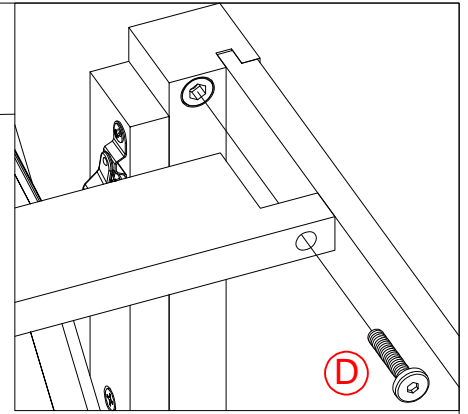
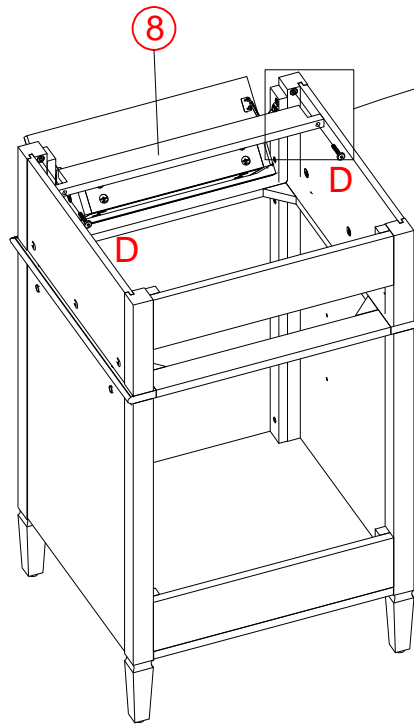

STEP 20



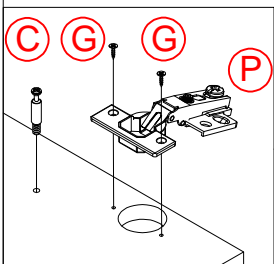
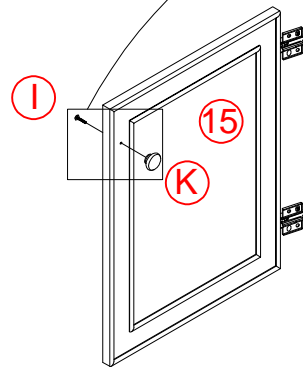
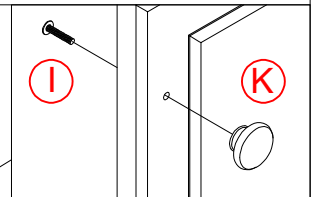
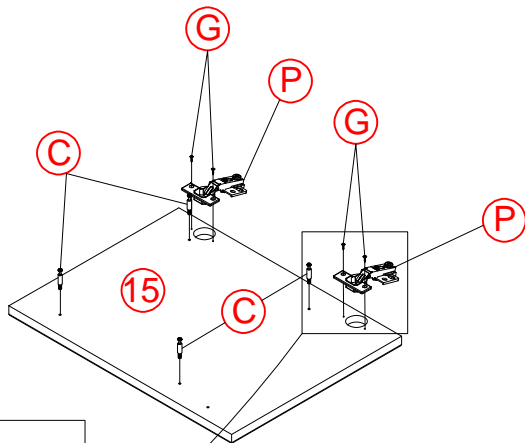

D	M6*30MM		2PCS
----------	---------	---	------

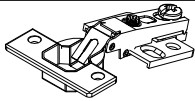
STEP 21



P	HINGES		2PC
K	Ø30mm		1PC
I	M4*20MM		1PC

C	Ø5*35MM		4PCS
G	3.5*12MM		4PCS

STEP 22

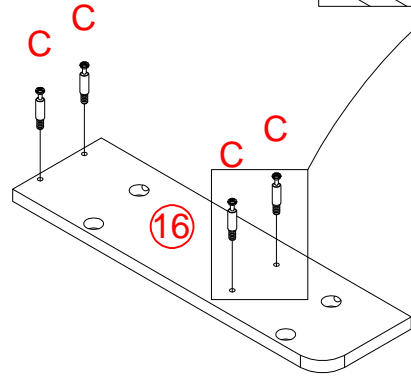
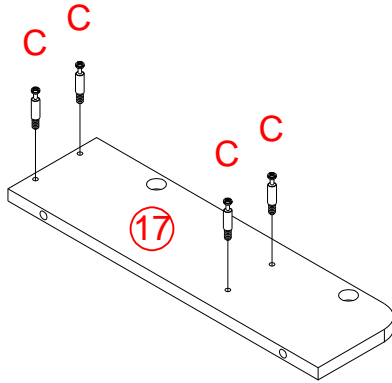

Ⓒ	Ø5*35MM		8PCS
---	---------	---	------

STEP 23

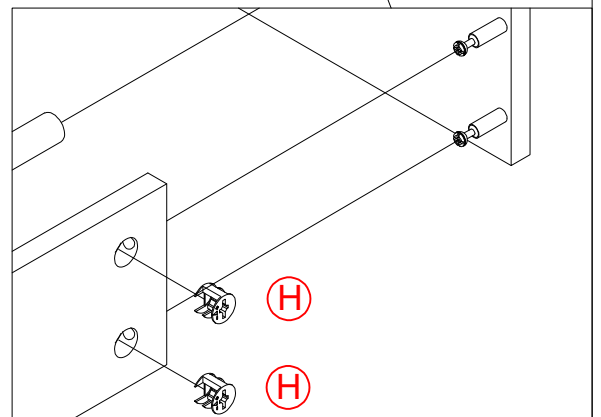
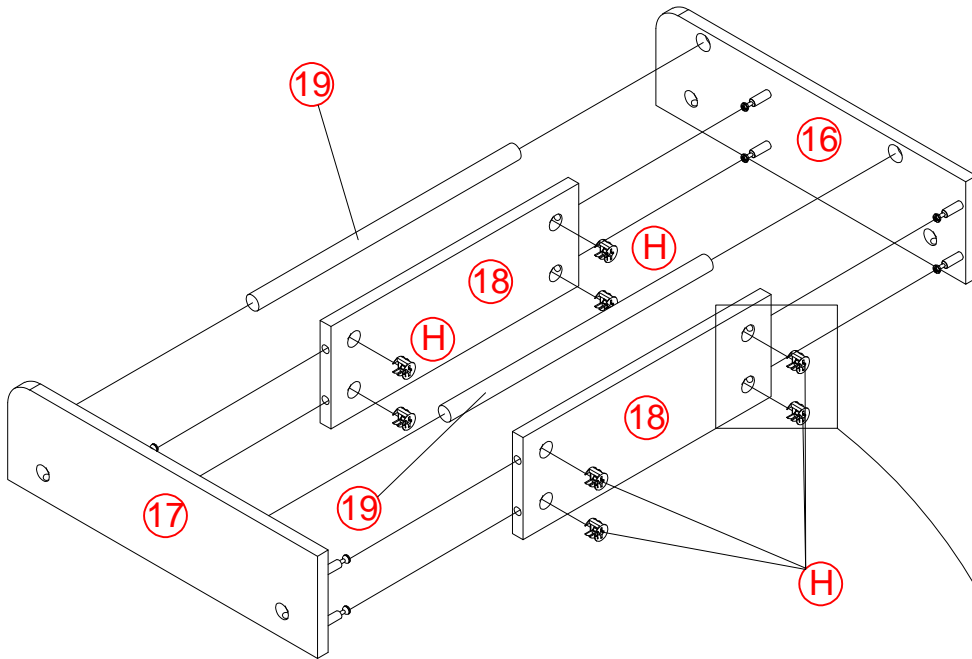

Ⓗ	Ø15*10MM		8PCS
---	----------	---	------

STEP 24

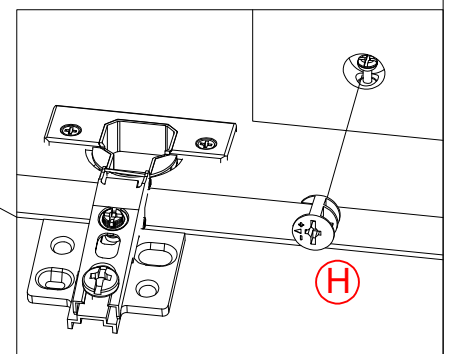
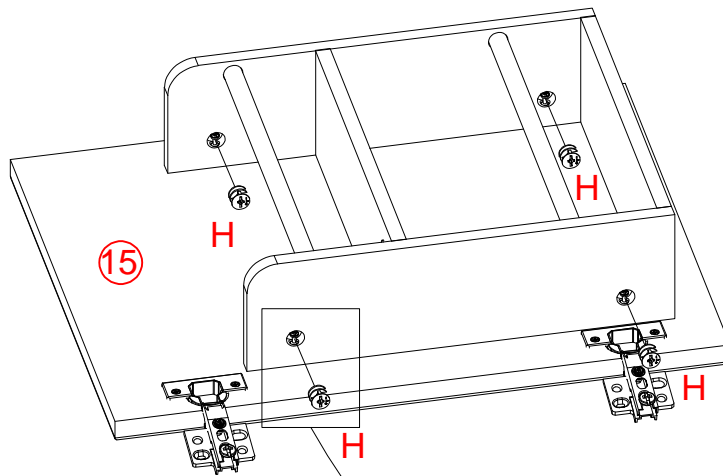
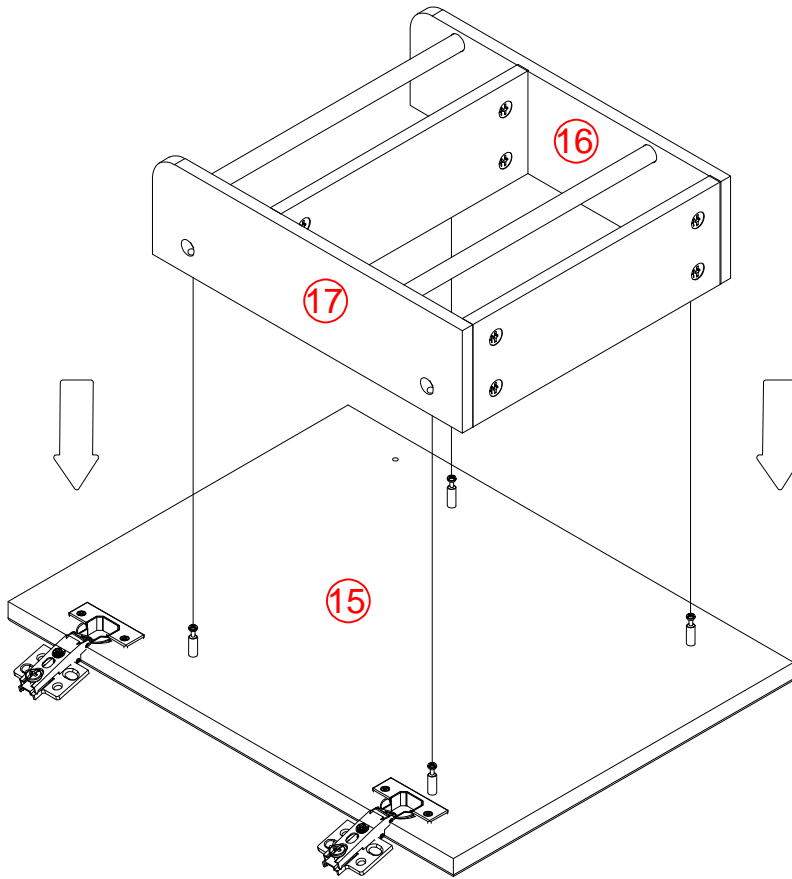

	Ø15*10MM		4PCS
---	----------	---	------

STEP 25

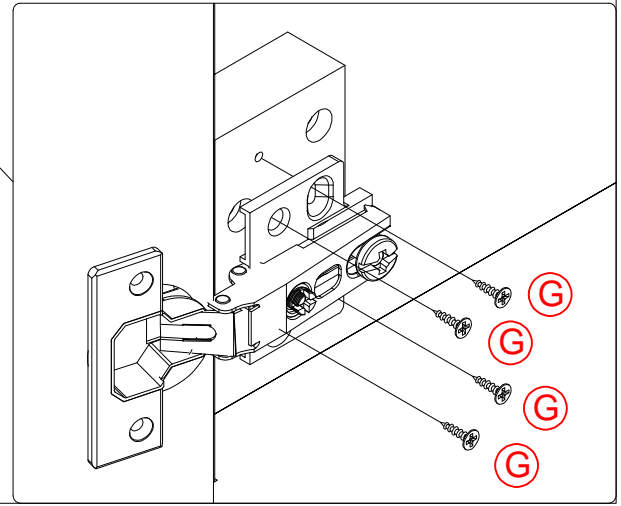
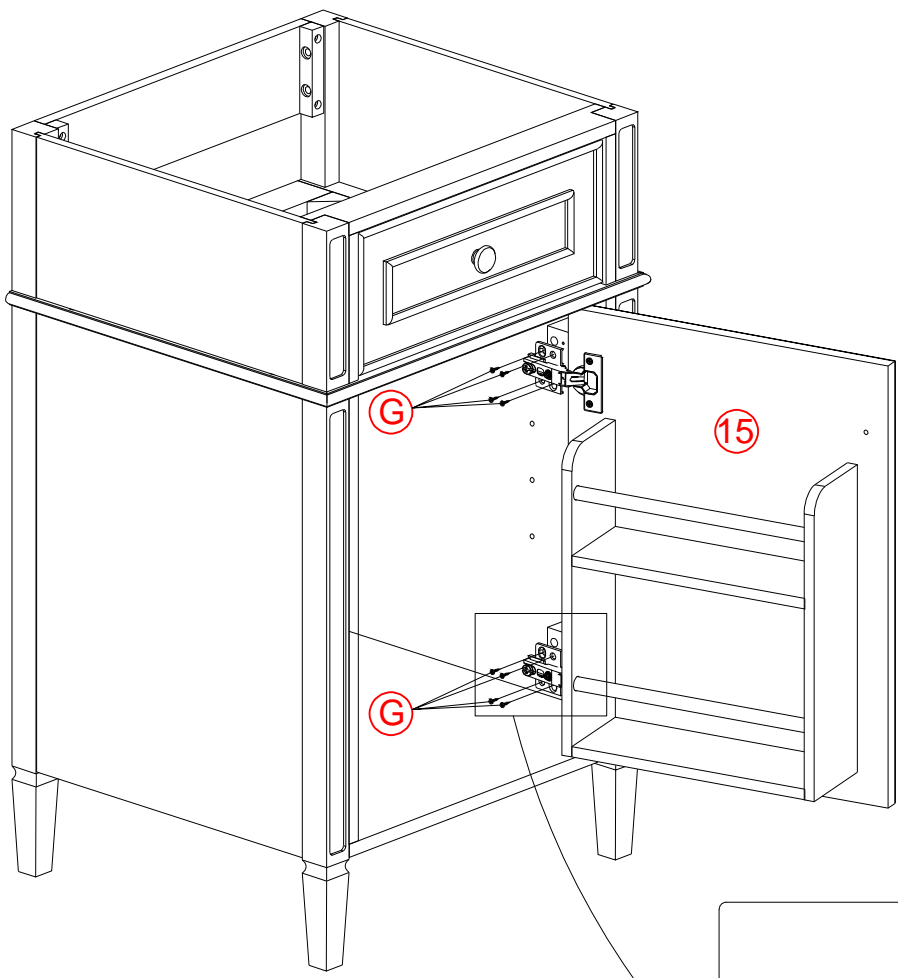
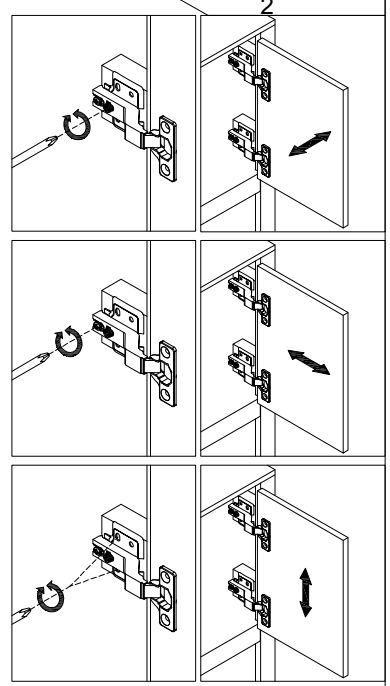
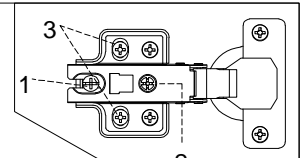

Three-way adjustable hinge for perfectly aligned doors
1.TO ADJUST DOOR FORWARD OR BACKWARD.
2.TO ADJUST DOOR TO RIGHT OR TO LEFT.
3.TO ADJUST DOOR UP OR DOWN.

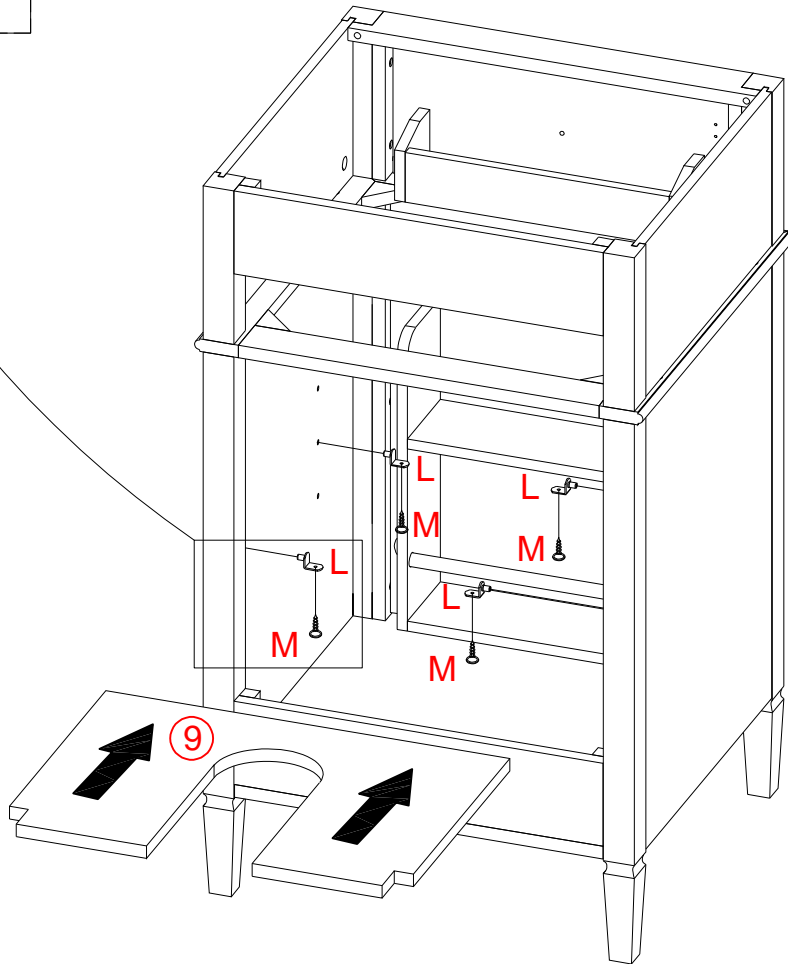
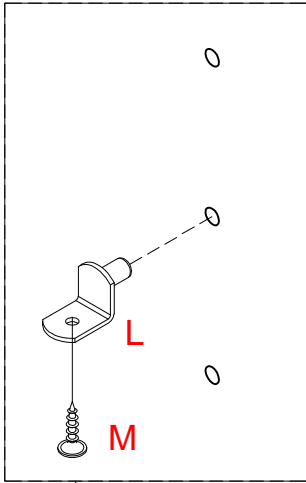

G	3.5*12MM		8PCS
---	----------	---	------

STEP 26

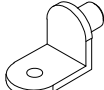

 (M)	3.5*12MM		4PCS	 (L)	L15MM		4PCS
---	----------	---	------	---	-------	---	------

STEP 27



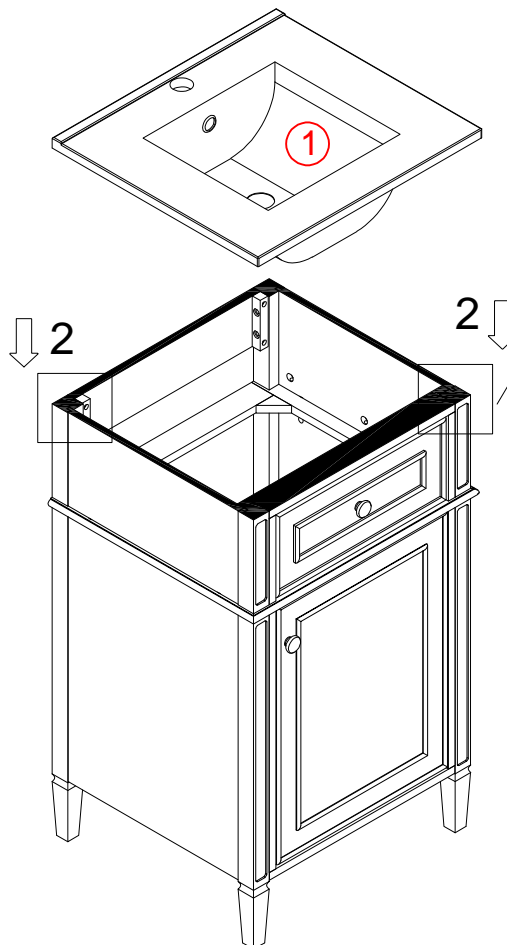
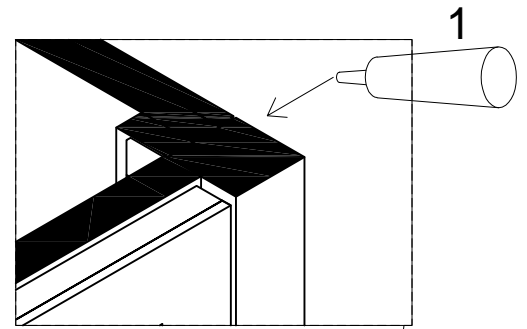

To install the Top (1) to the vanity (2).
Apply silicone caulk to the top edge of the wood cabinet. With the help of another adult, gently lower the Sink top with assembled sink onto the cabinet. Make sure the Sink top is flush with the back side of the wood cabinet and the wood cabinet left and right side walls.

Pour installer le plan de travail (1) sur le meuble-lavabo (2), appliquez du mastic silicone sur le bord supérieur du meuble en bois. Avec l'aide d'un autre adulte, abaissez délicatement le plan de travail avec le lavabo assemblé sur le meuble. Assurez-vous que le plan de travail est bien aligné avec l'arrière du meuble en bois et les parois latérales gauche et droite du meuble.

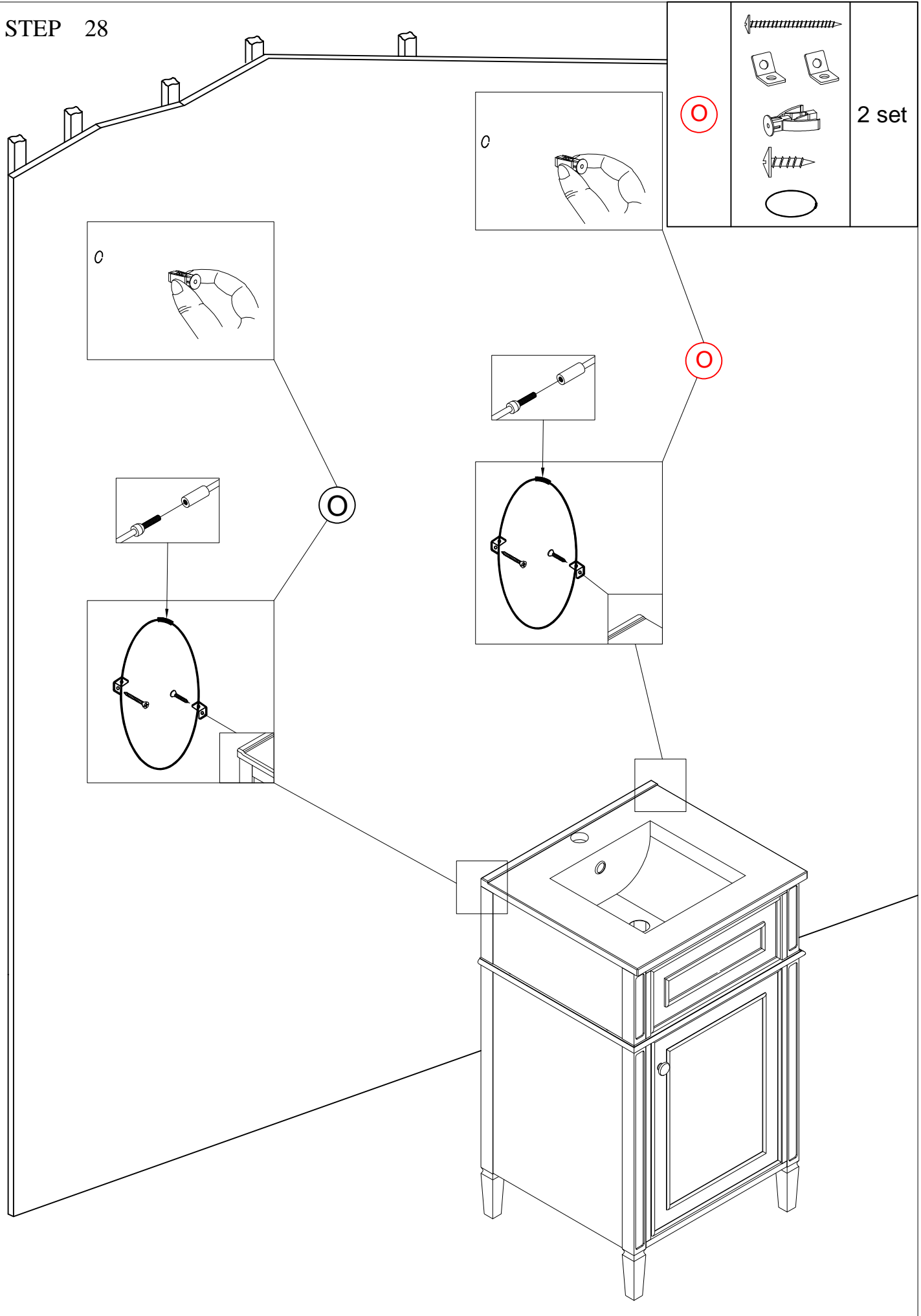

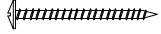
STEP 28

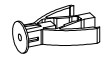

- 
- 
- 
- 
- 

2 set

HINGE ADJUSTMENTS

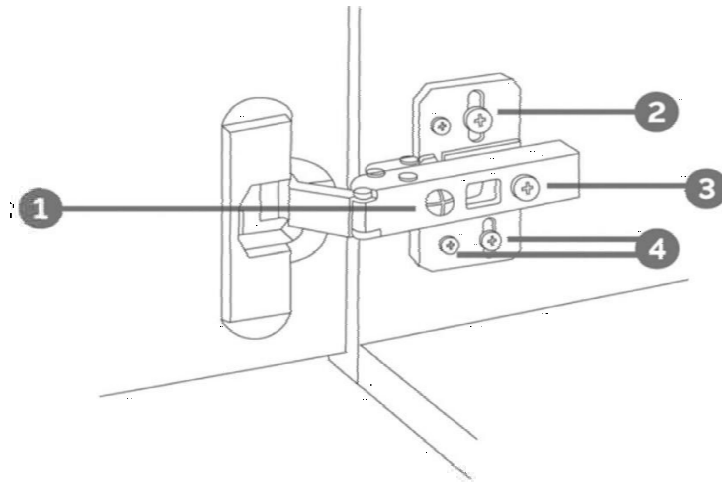

1 Sideways / Tilt adjustment

Turn the screw
clockwise to move the door further away from
the side of the cabinet
anticlockwise to move the door closer to the
side of the cabinet

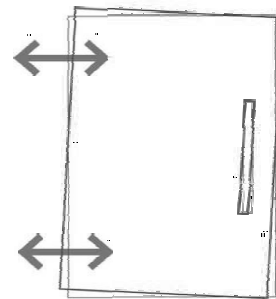

2 4 Height adjustment

While supporting the weight of the door, turn the
screws
clockwise to move the door up
anticlockwise to move the door down

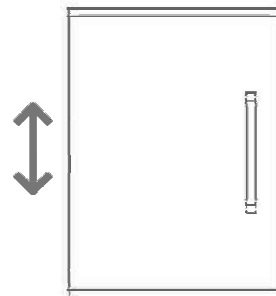

3 Forward and back adjustment

If the gap between the back of the door and the
cabinet is too small, and the door may not close
fully. Turn the screw
clockwise to decrease the gap between the
door and the cabinet
anticlockwise to increase the gap between the
door and the cabinet

