

**PLEASE READ THESE INSTALLATION INSTRUCTIONS THOROUGHLY PRIOR TO INSTALLING THIS GRAB BAR**

**IMPORTANT: THIS PRODUCT SHOULD ONLY BE INSTALLED BY QUALIFIED AND TRAINED PERSONNEL**

**FAILURE TO FOLLOW THESE INSTRUCTIONS COULD LEAD TO IMPROPER INSTALLATION OF THE GRAB BAR, STRUCTURAL AND/OR WATER DAMAGE TO THE WALL AND IN-WALL SUPPORT STRUCTURES, AND/OR SERIOUS BODILY INJURY IN USE. IN ADDITION, ALL WARRANTIES, EXPRESS OR IMPLIED, WILL BE NULL & VOID DUE TO IMPROPER INSTALLATION OF THIS PRODUCT. THE MANUFACTURER DOES NOT ASSUME ANY LIABILITY FOR DAMAGE RESULTING FROM SERVICES PERFORMED BY OTHERS, OR FAULTY INSTALLATION, MISUSE OR MISAPPLICATION OF GOODS.**

**THIS PRODUCT IS DESIGNED TO MEET OR EXCEED ALL LOAD REQUIREMENTS ESTABLISHED IN THE FEDERAL SPECIFICATION #WW-P-541/8b AT 250 POUNDS OF FORCE. THE PERFORMANCE OF THIS PRODUCT IS SIGNIFICANTLY IMPACTED BY THE STRENGTH OF THE WALL TO WHICH IT IS ATTACHED.**

**TO ASSURE PROPER AND SAFE INSTALLATION, THIS GRAB BAR MUST BE INSTALLED INTO A MINIMUM 2" THICK, SOLID WOOD, IN-WALL BACKING MATERIAL. MAKE CERTAIN IN-WALL BACKING COMPLIES WITH ALL LOCAL BUILDING CODE REQUIREMENTS.**

**1. Locating the Grab Bar in the desired position.**

Remove the Wall-To-Floor Swing-Away Grab Bar (GW-4339-Series) from the shipping carton.

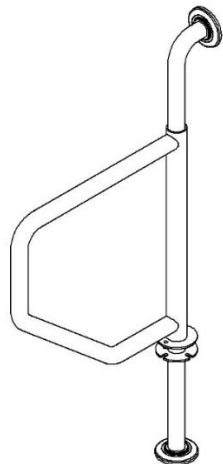

Locate the area with 2" solid wood in-wall backing on the desired mounting surface of the wall and floor.

Place the bar in position on the wall making sure the bar has contact with the floor. Using a level (not provided) ensure the grab bar is level and pencil-mark the location of the mounting holes on the wall and the floor.

**Note:** This bar has three (3) locking positions. Use caution when rotating the bar to ensure there are no obstacles preventing the bar from rotating and safely resting in the next locking position.

Using a pencil or suitable marker, it is **extremely important** you mark the center of each of the six (6) mounting holes precisely on the mounting surface of the wall and the floor.

# INSTALLATION INSTRUCTIONS

GW-4339-QCR  
Wall-To-Floor Swing-Away Grab Bar  
LIFESTYLE & WELLNESS®

**Proceed cautiously through the following steps in this installation process to avoid drilling into in-wall water supply lines.**

**All mounting points must fasten into structural wood backing, minimum 2" thickness.  
Avoid electrical and/or plumbing behind the wall, and where possible drill through tile – not through grout.**

## 2. Mounting the Grab Bar.

### Step #1

Use a power drill with a 3/32" carbide tip drill bit (not provided) and drill at the six (6) locations marked on the wall and the floor. Ensure the bar is installed into the 2" thick solid wood in-wall backing.

### Step #2

Apply a bead of silicone between the Grab Bar Mounting Flanges and the mounting surface to ensure a water-tight seal will be created at all mounting locations. Secure the grab bar to the wall using six (6) #10 x 2-1/2" stainless steel screws (supplied by manufacturer) and screw into the 3/32" holes created in the solid wood backing. *Tighten screws completely after ALL screws are in place.* Complete the grab bar installation by covering the mounting flanges with the Concealed Flange Covers, snapping them into place.

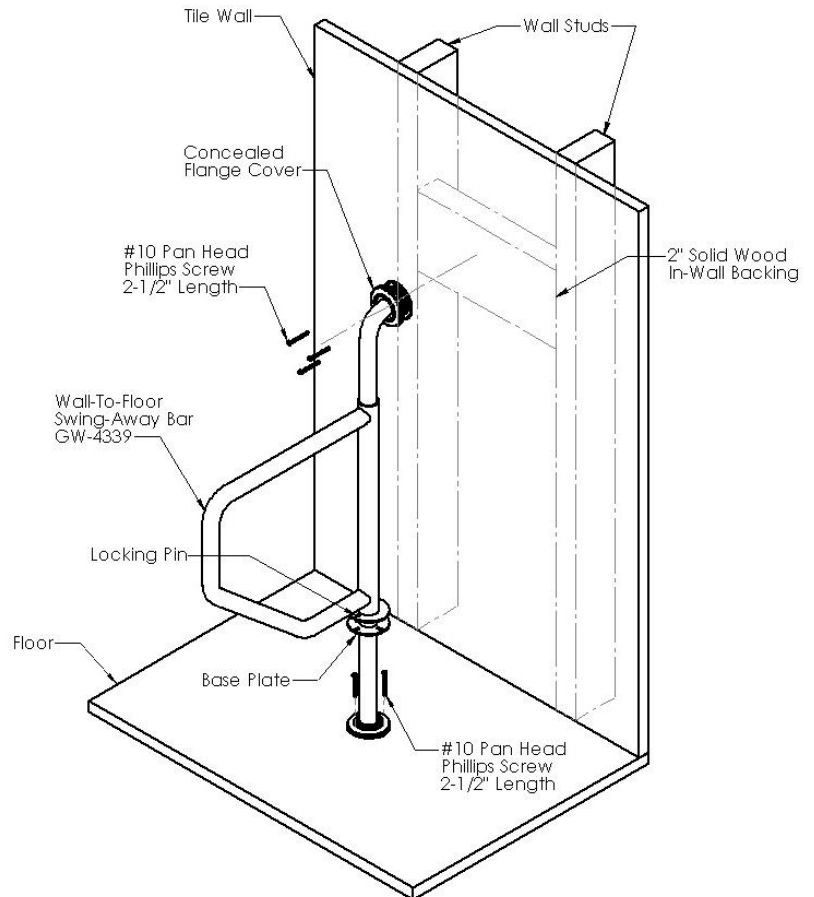
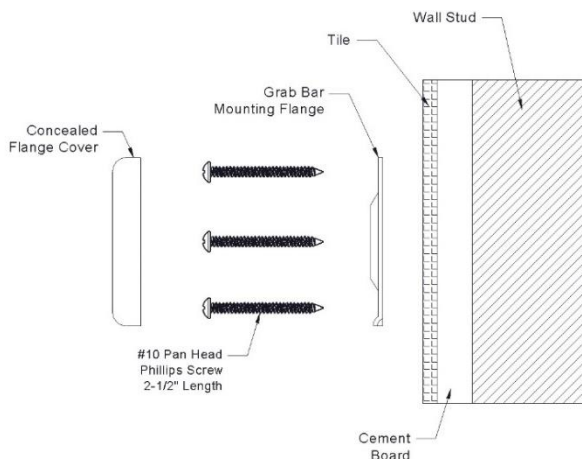

### Step #3

Before use, raise the Swing-Away Arm of the grab bar and move into position, making sure the locking pin is secure in the slot on the Base Plate when lowered into place.

**DO NOT EXCEED 250 POUNDS OF FORCE IN USE.**

**To ensure proper and safe installation, the grab bar should not shift in any direction on the mounting surface.**

**Hardware Provided:** (6) #10 x 2-1/2" Phillips Pan Head sheet metal screws.

**Tools required:** Marking pencil/pen, level, power drill, 3/32" carbide tip drill bit, #2 phillips driver, silicone.

**THIS COMPLETES THE INSTALLATION OF THIS GRAB BAR.**