

ASSEMBLY INSTRUCTION

ITEM NO.:WF532198

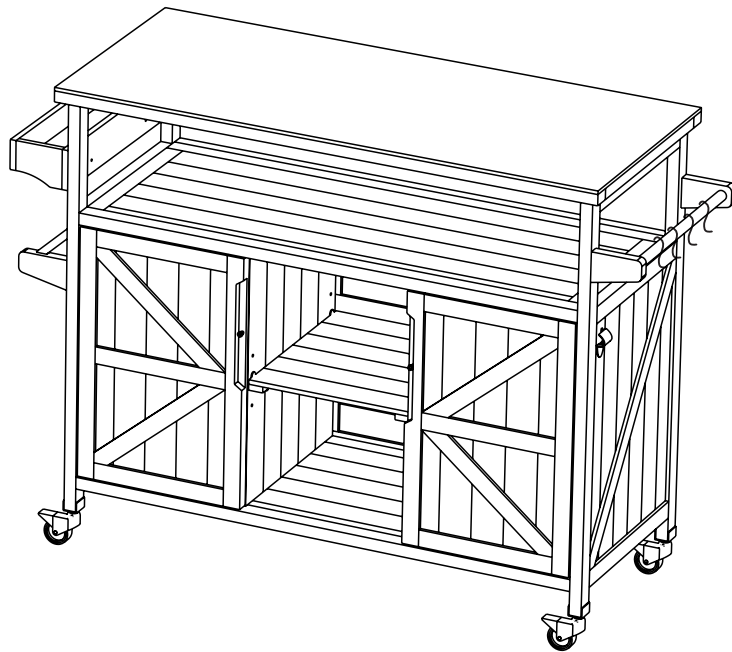







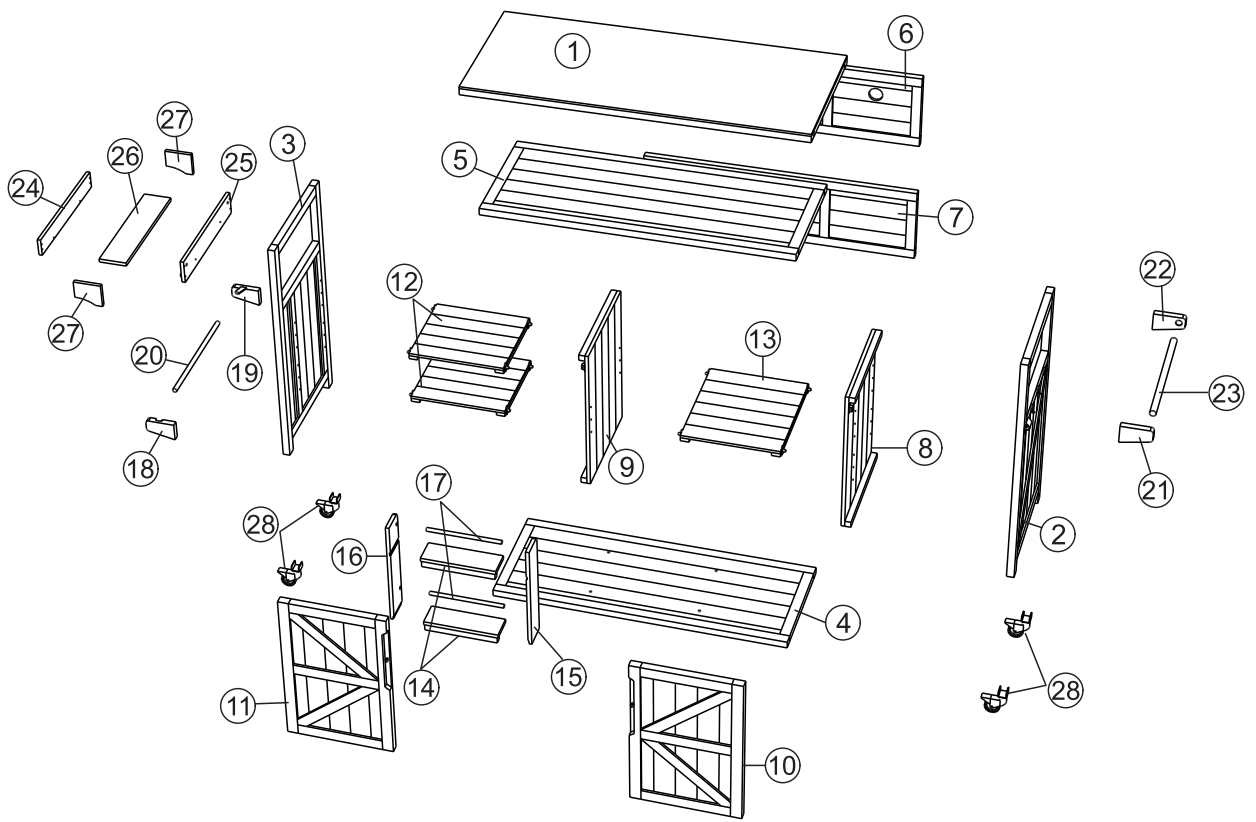



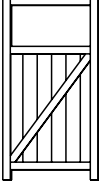
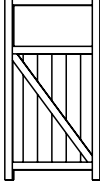
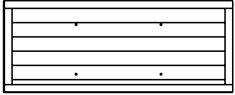
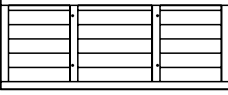
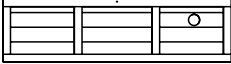

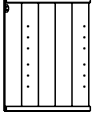
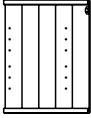
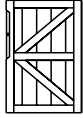
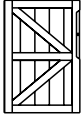





IMPORTANT NOTE:

- ① PLACE ALL PARTS ON A CLEAN AND SMOOTH SURFACE SUCH AS A RUG OR CARPET TO AVOID THE PARTS FROM BEING SCRATCHED.
- ② BEFORE YOU BEGIN, KINDLY FOLLOW THE ASSEMBLY INSTRUCTIONS STEP BY STEP.
- ③ DO NOT TIGHTEN ALL SCREWS AND BOLTS UNTIL THIS ITEM IS FULLY SET-UP.





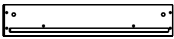
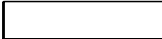







Detail View



WF532198

1		2		3		4	
	Table-1pc		Right panel-1pc		Left panel-1pc		Bottom panel-1pc
5		6		7		8	
	Top panel-1pc		Upper back panel-1pc		Lower back panel-1pc		Right middle panel-1pc
9		10		11		12	
	Left middle panel-1pc		Right door-1pc		Left door-1pc		Layer for side pat-2pcs
13		14		15		16	
	Layer for middle part-1pc		Lay of storage rack-2pcs		Left panel of storage rack-1pc		Right panel of storage rack-1pc
17		18		19		20	
	Wooden stick of storage rack-2pcs		Rear part of left push rod-1pc		Front part of left push rod-1pc		Left push rod-1pc
21		22		23		24	
	Front part of right push rod-1pc		Rear part of right push rod-1pc		Right push rod-1pc		Front panel of outer storage rack-1pc
25		26		27		28	
	Back panel of outer storage rack-1pc		Bottom panel of outer storage rack-1pc		Side panel of outer storage rack-2pcs		Wheels with brake-4pcs

Hardware List

<p>A</p>  <p>∅ 6.0*30</p>	<p>B</p>  <p>∅ 3.0*28</p>	<p>C</p>  <p>∅ 3.0*18</p>	<p>D</p>  <p>∅ 3.5*40</p>	
Ph zinc bolt-2pcs		Ph zinc screws-20pcs		
Ph zinc screws-12pcs		Ph zinc screws-16pcs		
<p>E</p>  <p>∅ 3.5*50</p>	<p>F</p>  <p>∅ 4.0*35</p>	<p>G</p>  <p>∅ 6.0*15</p>	<p>H</p>  <p>∅ 3.5*60</p>	
Ph zinc screws-26pcs		Ph zinc bolt-4pcs		
Ph zinc bolt-2pcs		Ph zinc screws-4pcs		
<p>I</p> 	<p>J</p> 	<p>K</p> 	<p>L</p> 	<p>M</p> 
L shape metal support-12+4pcs		Hooks-4pcs		
Wood dowels-36pcs		Bottle opener-1pc		
Wrench-1pc				

ASSEMBLY TOOLS REQUIRED(NOT INCLUDED)



PLEASE BE CAREFUL DO NOT DAMAGE THE HOLE POSITION WHEN YOU USE POWERTOOLS !

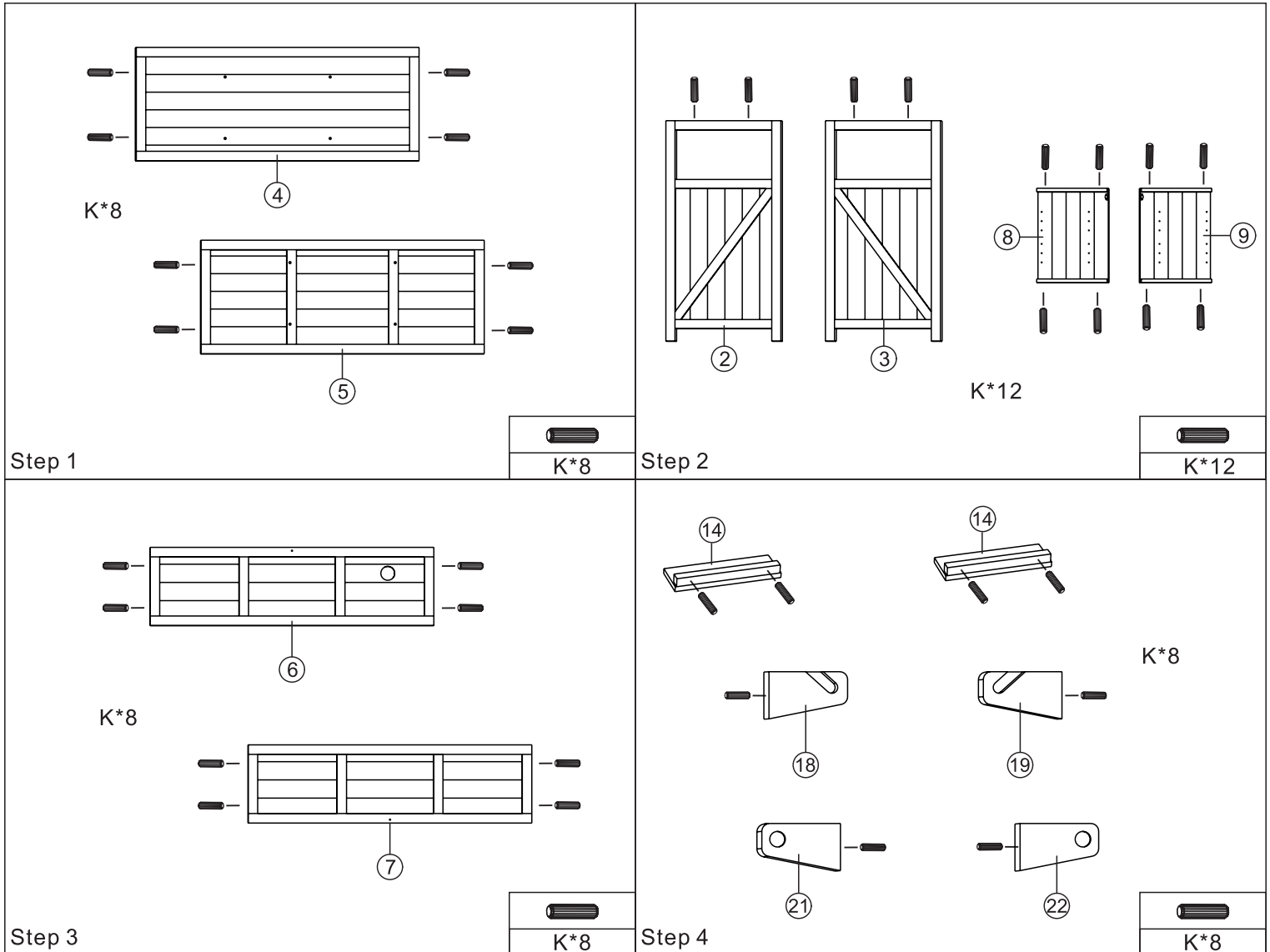

Attention: the direction of magnetic need to face forward
And there is gap on front part.

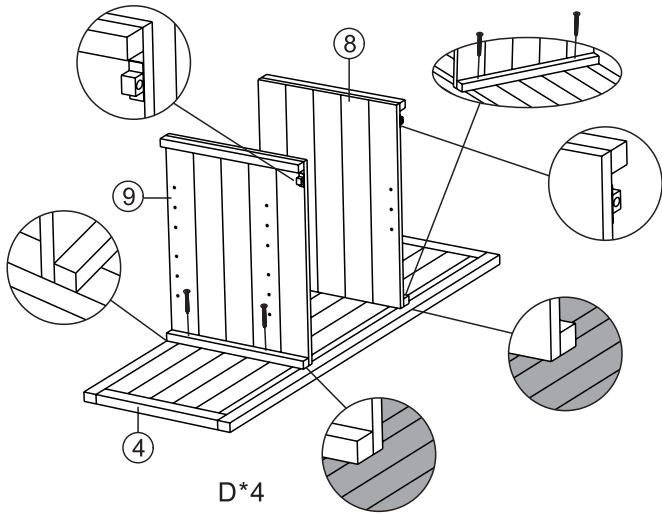

Step 5



Repeat same way for fixing Part 5
Attention: the direction of magnetic need to face forward
And there is gap on front part.

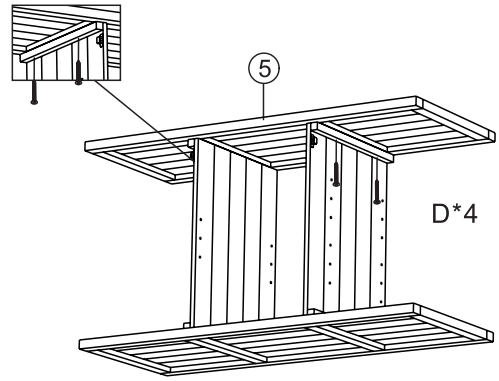

Step 6

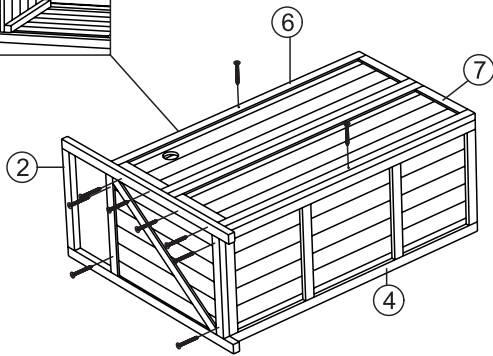
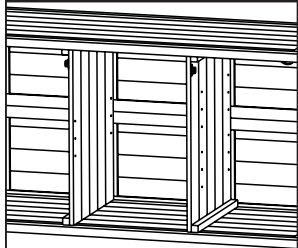

Step 7

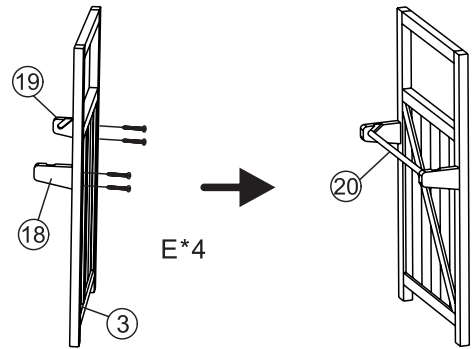

Step 8

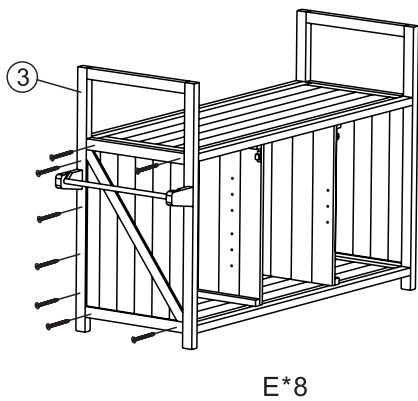

Step 9

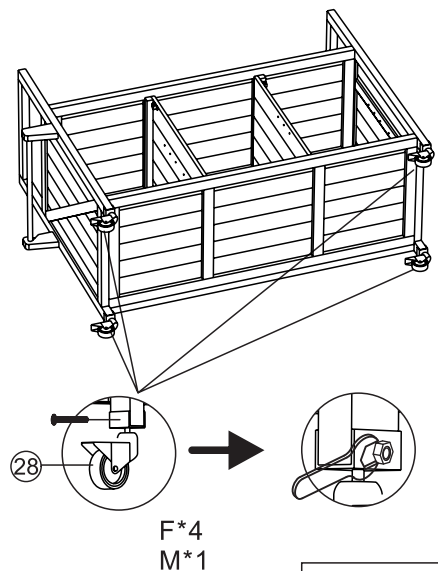

Step 10

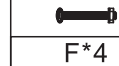

Place Part I on left side or right side as per your request.
So that place Part 12 on it.

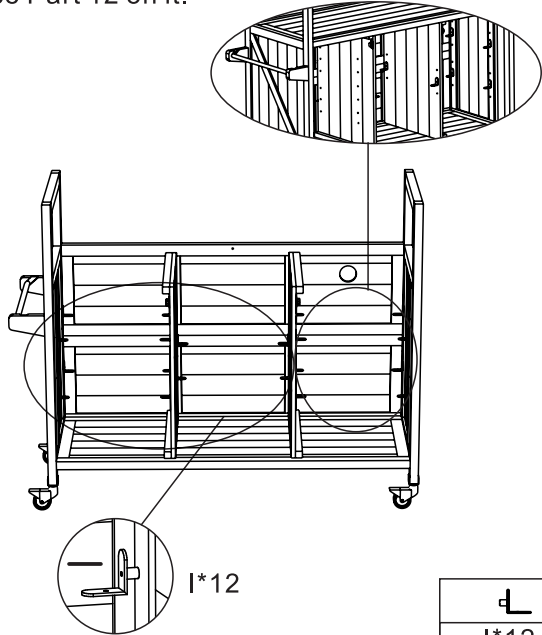

Step 11

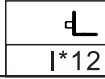

Place 2 x Part 12 on left or right
as per your own request.

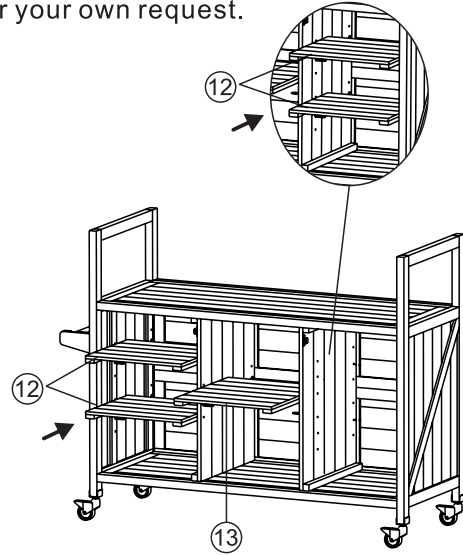

Step 12

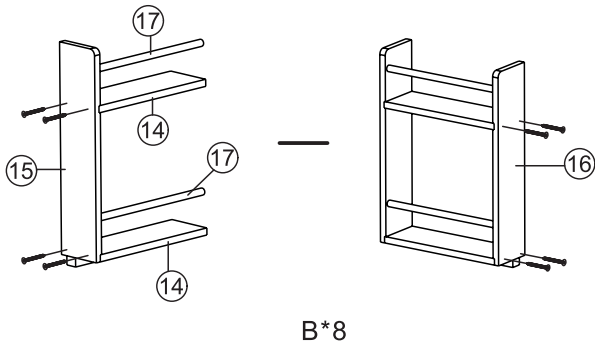

Step 13

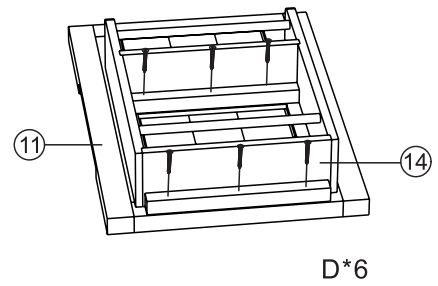

Step 14

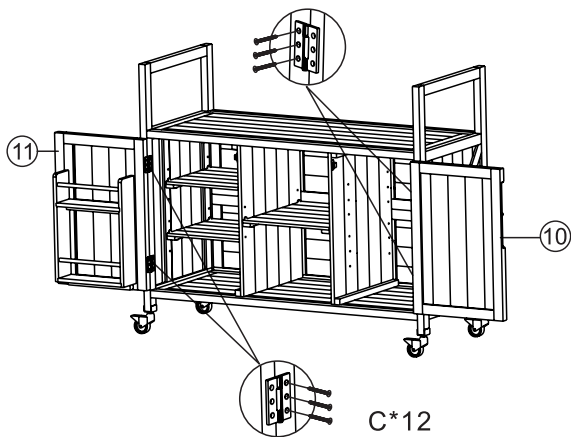
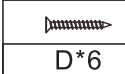

Step 15

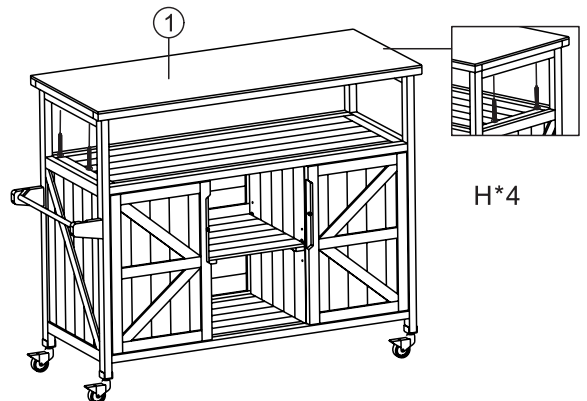
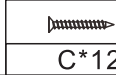

Step 16

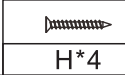

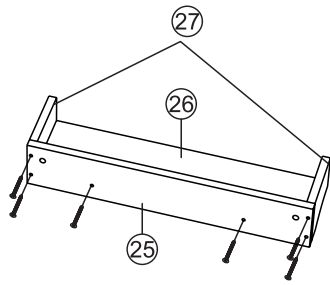

B*6

Step 17



B*6

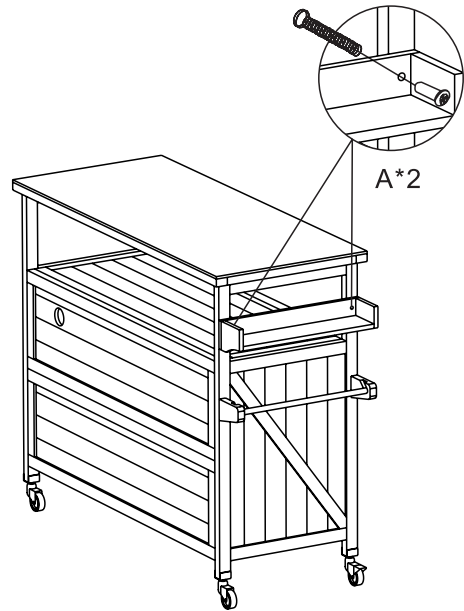

A*2

Step 18



A*2

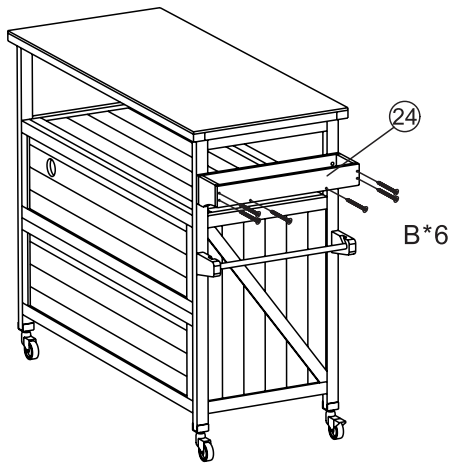

B*6

Step 19



B*6

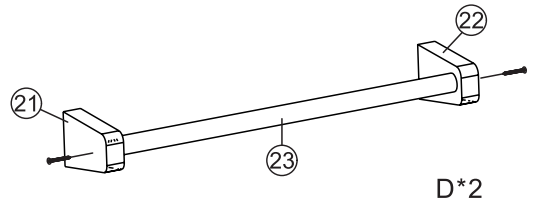

D*2

Step 20



D*2

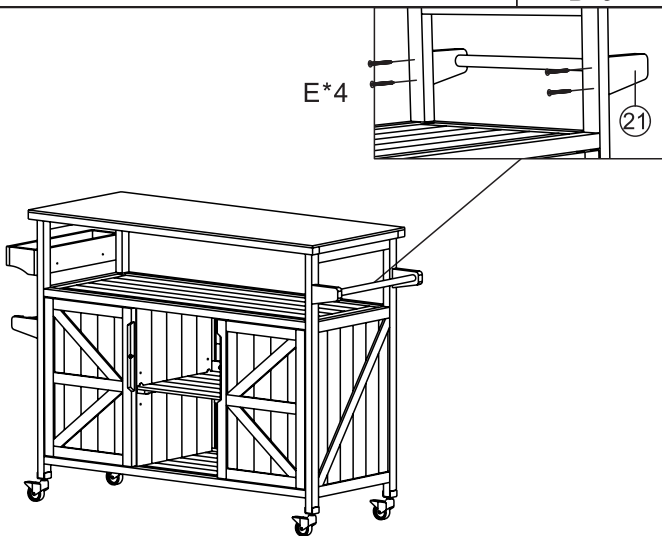

E*4

Step 21



E*4

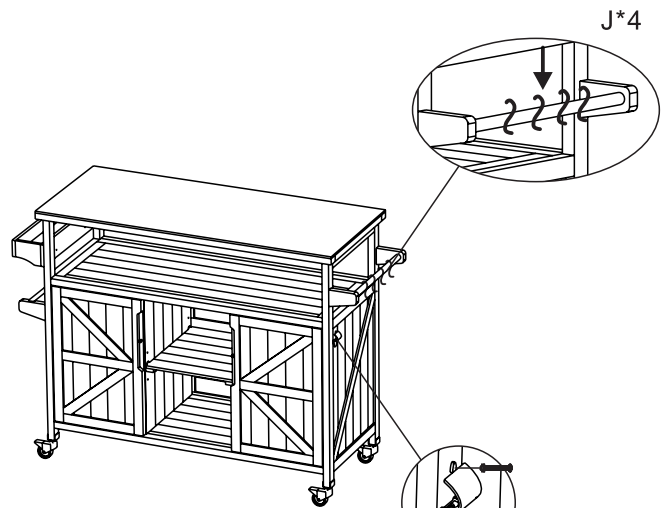

J*4

Step 22

L*1
G*2



G*2



J*4



L*1