

AJ-DJ505334

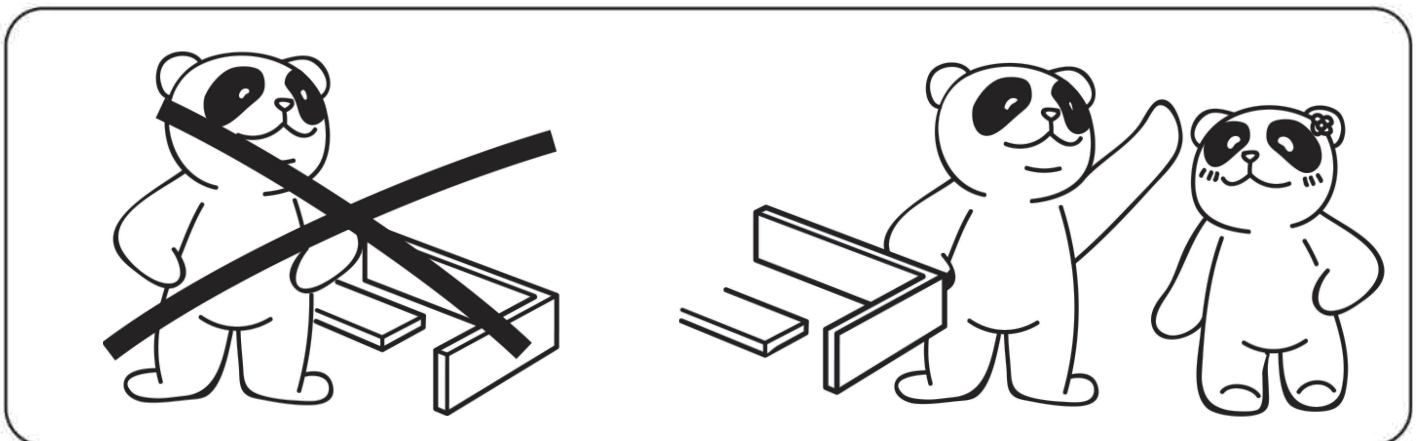

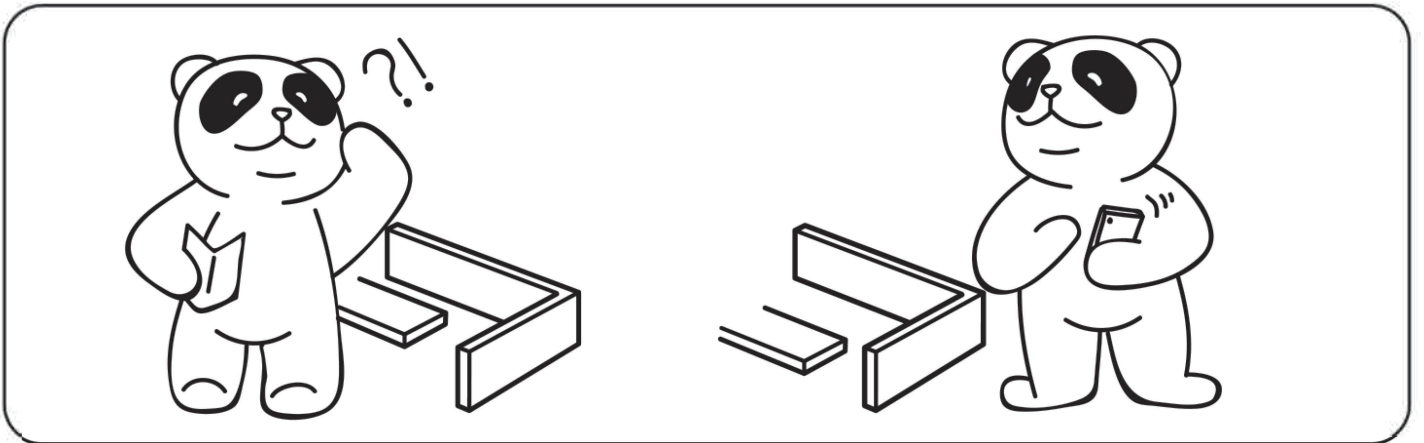
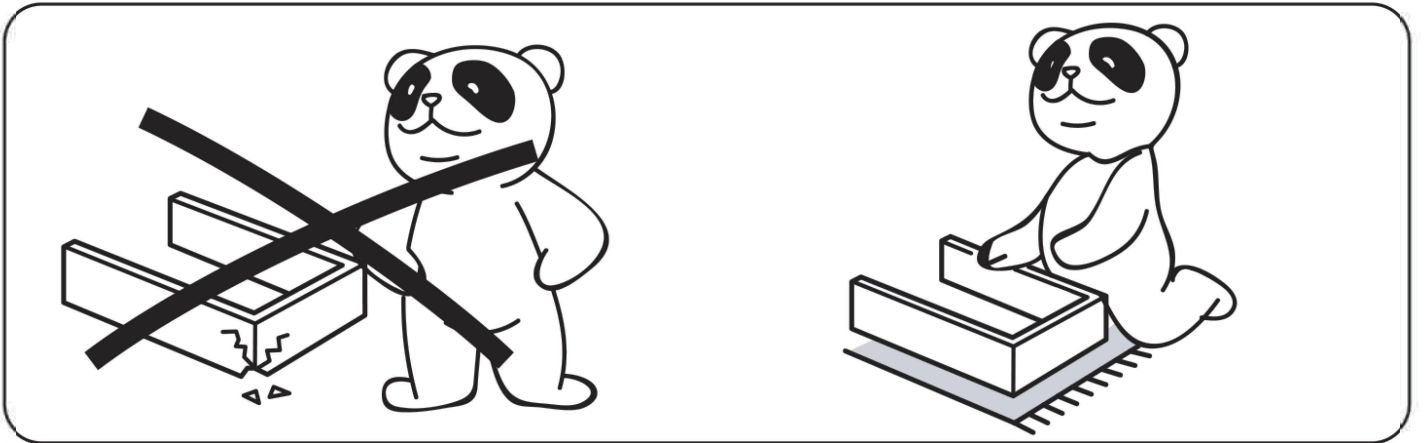
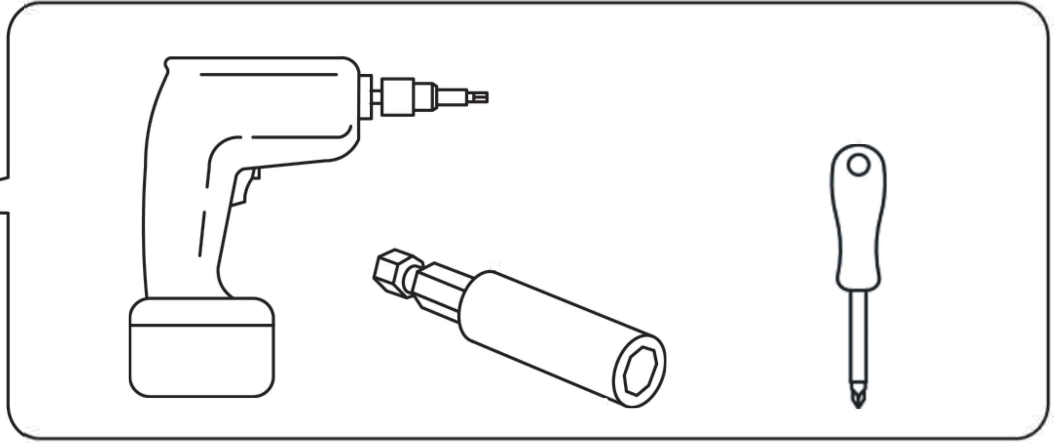
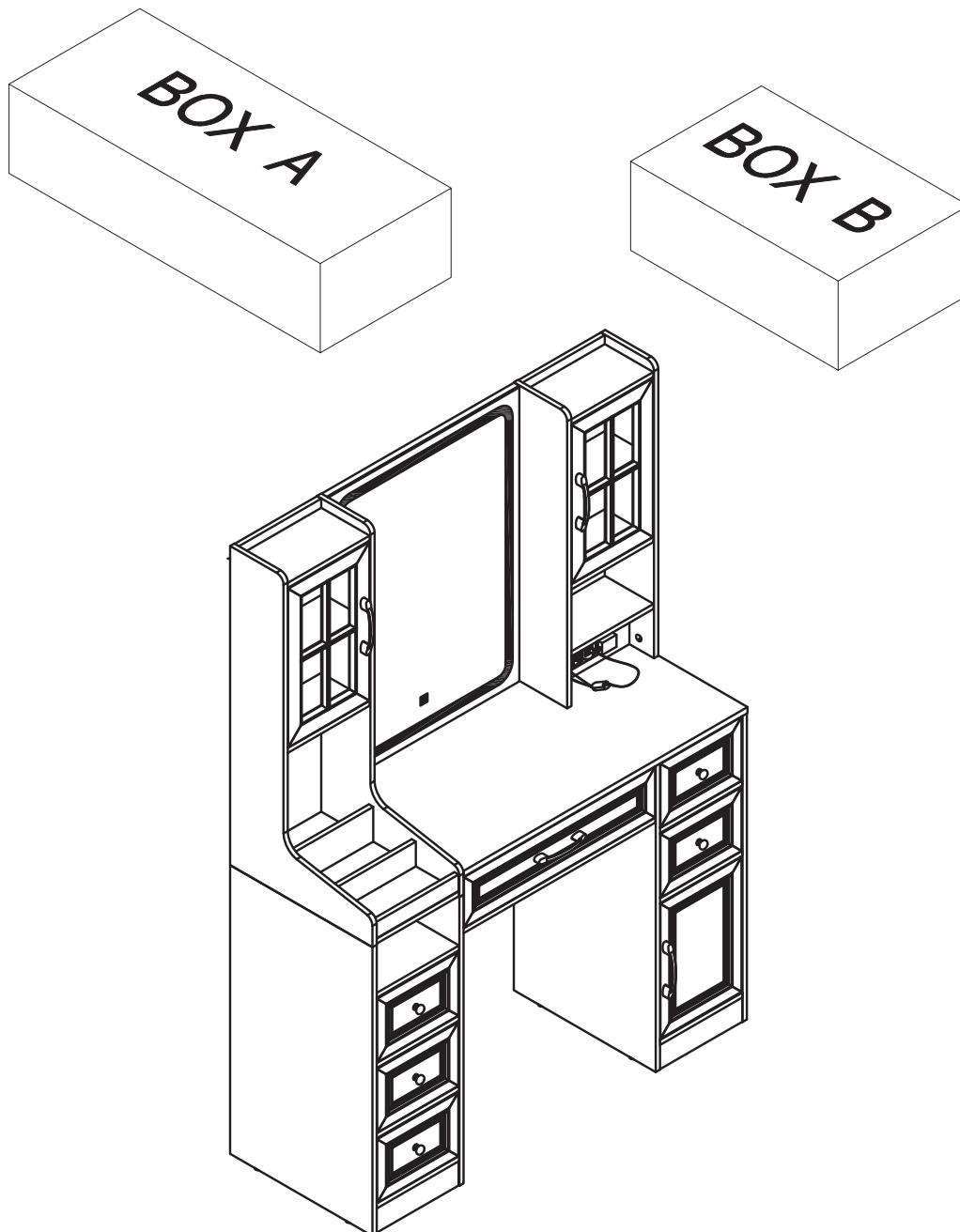

This product has two packages, box A and box B. Only the parts in the two packages can complete the entire table. Please be sure to start the installation after the two packages arrive

BOX SKU AJ-DJ503493_A

NO.	PARTS	QTY	NO.	PARTS	QTY	NO.	PARTS	QTY
(A)		x1	(M)		x1	(X)		x1
(B)		x1	(N)		x1	(Y)		x1
(C)		x1	(O)		x1	(Z)		x1
(D)		x2	(P)		x1	(BB)		x1
(F)		x1	(Q)		x1	(NN)		x1
(G)		x1	(R)		x1	(PP)		x1
(I)		x1	(S)		x1	(QQ)		x1
(J)		x1	(U)		x1			
(K)			(V)		x2			

BOX SKU AJ-DJ503493_B

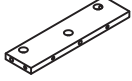
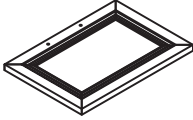
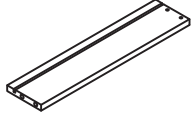
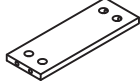
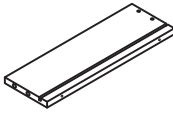
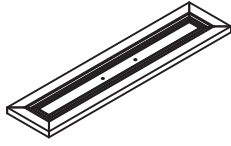
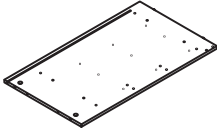
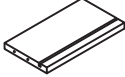
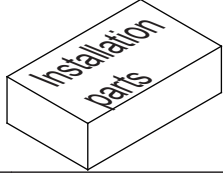
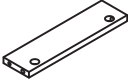
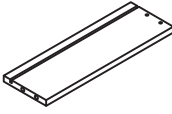
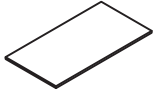
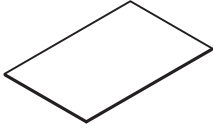
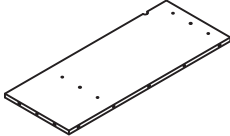
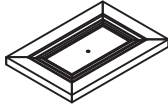
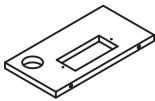
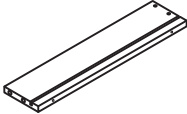
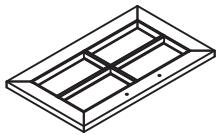
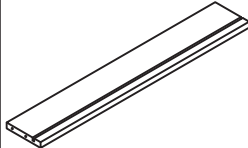
NO.	PARTS	QTY	NO.	PARTS	QTY	NO.	PARTS	QTY
(E)		x2	(EE)		x1	(MM)		x1
(H)		x4	(FF)		x5	(OO)		x1
(L)		x1	(GG)		x5			
(T)		x1	(HH)		x5			
(W)		x2	(II)		x5			
(AA)		x1	(JJ)		x5			
(CC)		x1	(KK)		x1			
(DD)		x2	(LL)		x1			

Board Identification

Not actual size

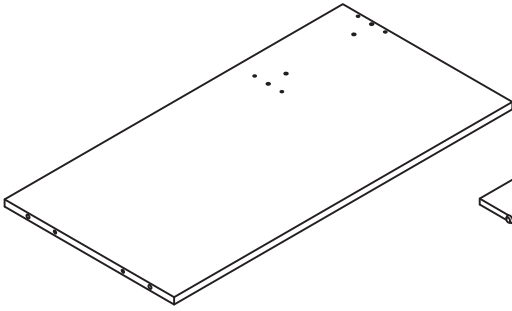

Ⓐ

Qty:1

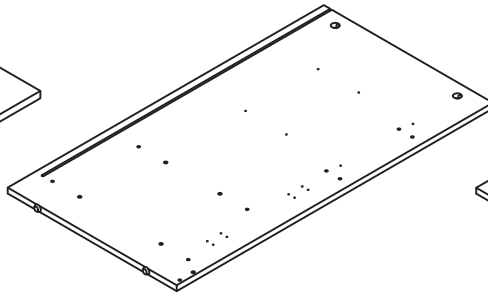

Ⓑ

Qty:1

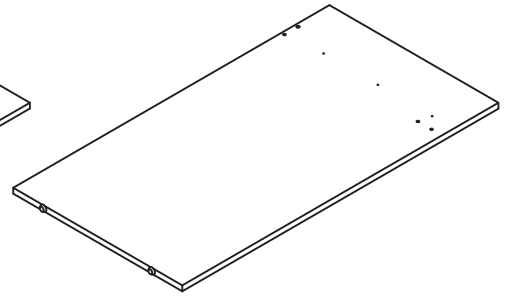

Ⓒ

Qty:1

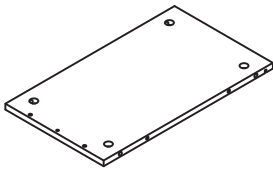

Ⓓ

Qty:2

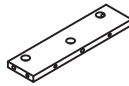

Ⓔ

Qty:2

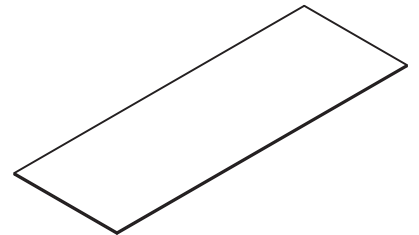

Ⓕ

Qty:1

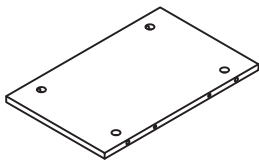

Ⓖ

Qty:1

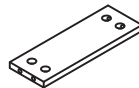

Ⓗ

Qty:4

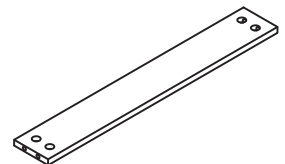

Ⓖ

Qty:1

Board Identification

Not actual size

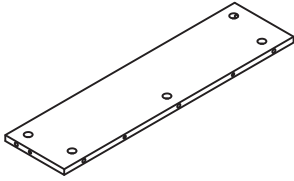

ⓐ

Qty:1

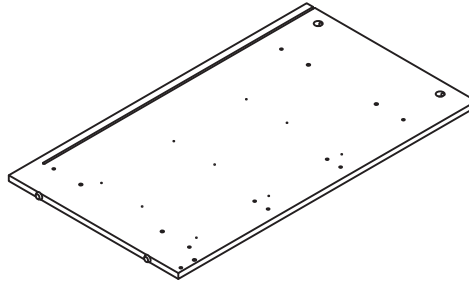

ⓑ

Qty:1

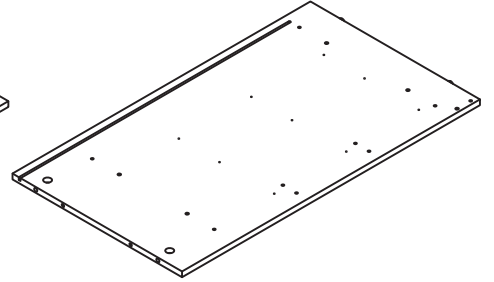

ⓒ

Qty:1

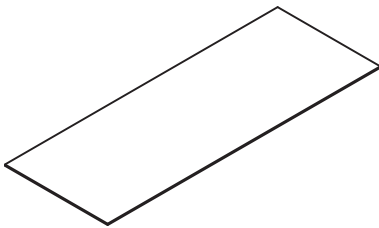

ⓓ

Qty:1

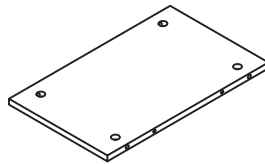

ⓔ

Qty:1

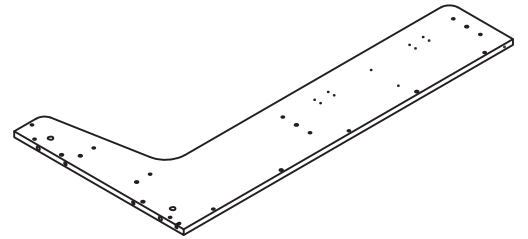

ⓕ

Qty:1

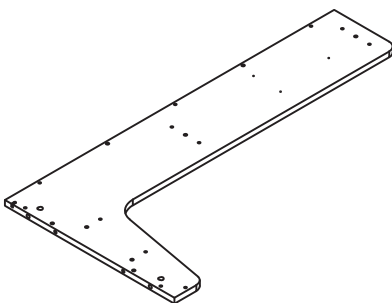

ⓖ

Qty:1

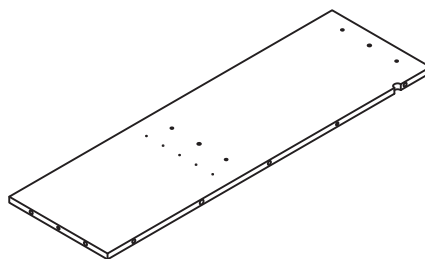

ⓗ

Qty:1

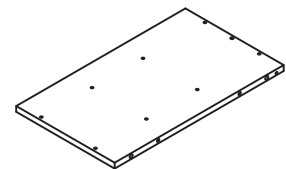

ⓘ

Qty:1

Board Identification

Not actual size

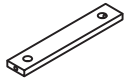

Ⓢ

Qty:1

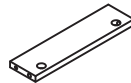

Ⓣ

Qty:1

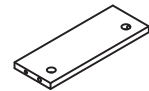

Ⓤ

Qty:1

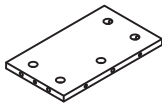

Ⓥ

Qty:2

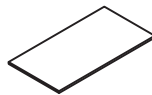

Ⓦ

Qty:2

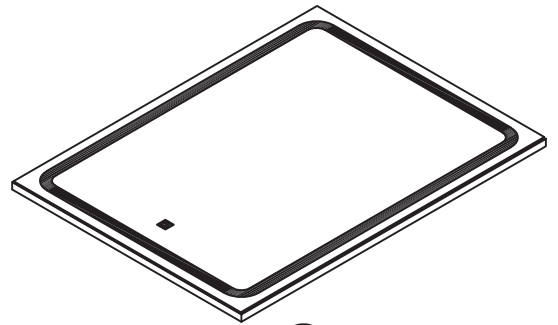

Ⓧ

Qty:1

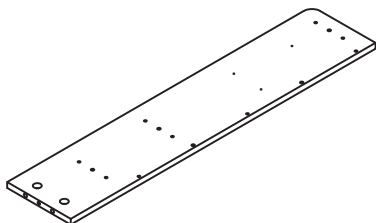

Ⓨ

Qty:1

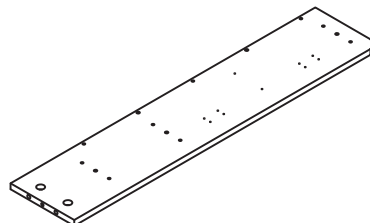

Ⓩ

Qty:1

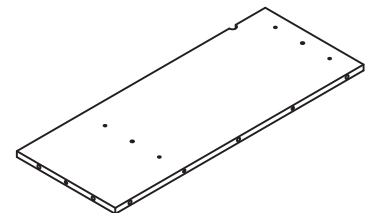

ⒶⒶ

Qty:1

Board Identification

Not actual size

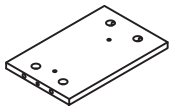

Ⓟ

Qty:1

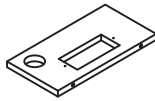

Ⓞ

Qty:1

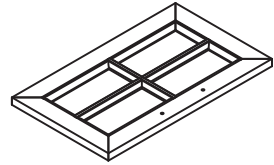

Ⓞ

Qty:2

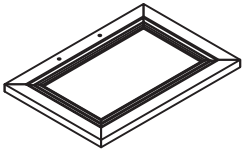

Ⓞ

Qty:1

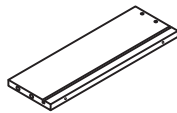

Ⓞ

Qty:5

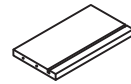

Ⓞ

Qty:5

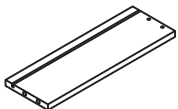

Ⓞ

Qty:5

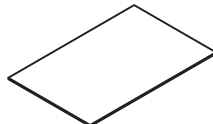

Ⓞ

Qty:5

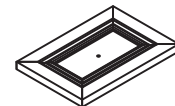

Ⓞ

Qty:5

Board Identification

Not actual size

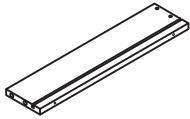

ⓀⓀ

Qty:1

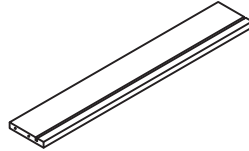

ⓁⓁ

Qty:1

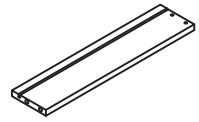

ⓂⓂ

Qty:1

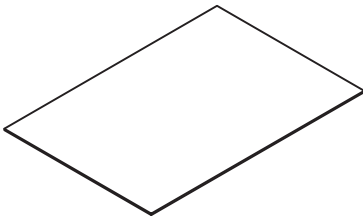

ⓃⓃ

Qty:1

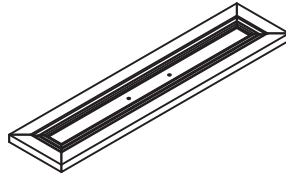

ⓄⓄ

Qty:1

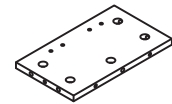

ⓅⓅ

Qty:1

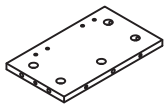

ⓆⓆ

Qty:1

Part List

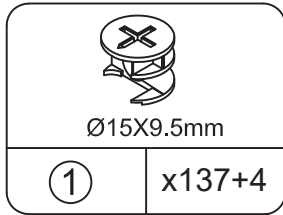

CAM LOCK

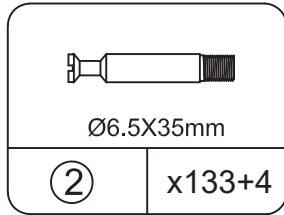

CAM BOLT

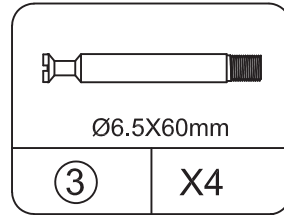

CAM BOLT

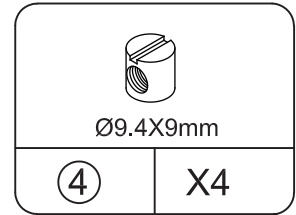

CAM LOCK

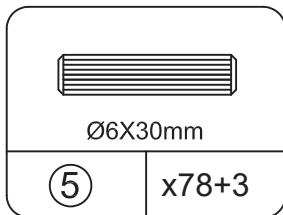

WOOD DOWEL

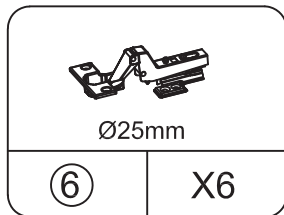

HINGE

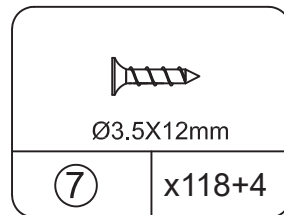

SCREW

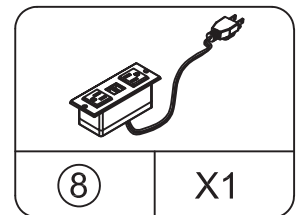

POWER STRIP

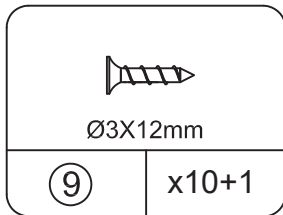

SCREW

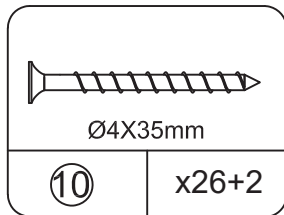

SCREW

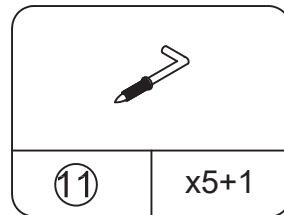

HOOKING

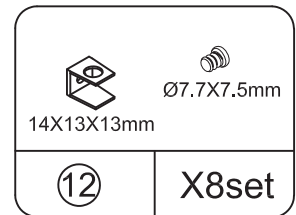

SHELF SUPPORT

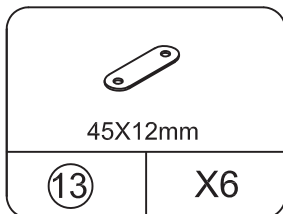

IRON SHEETS

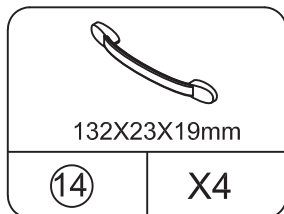

HANDLE

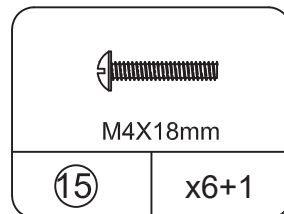

SCREW

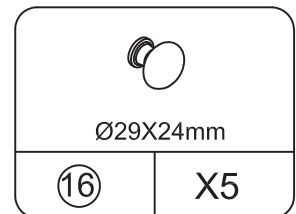

HANDLE

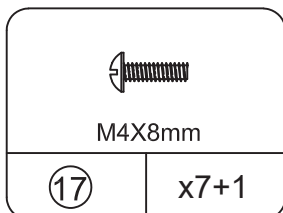

SCREW

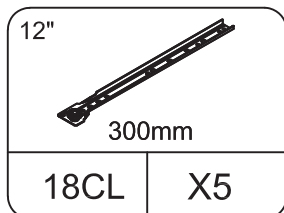

LEFT CABINET MEMBER

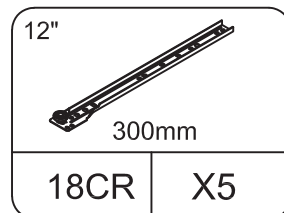

RIGHT CABINET MEMBER

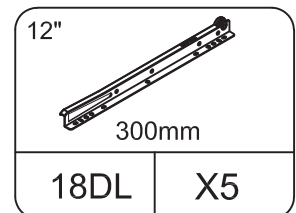

LEFT DRAWER RUNNER

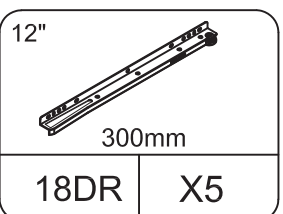

RIGHT DRAWER RUNNER

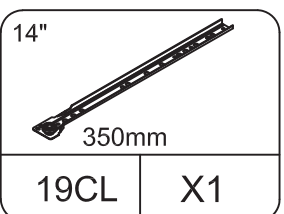

LEFT CABINET MEMBER

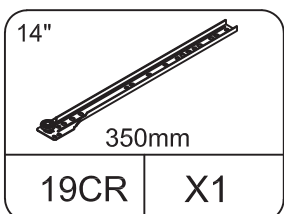

RIGHT CABINET MEMBER

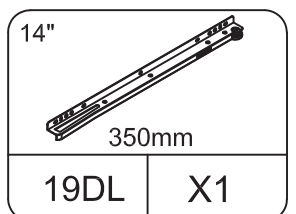

LEFT DRAWER RUNNER

Part List

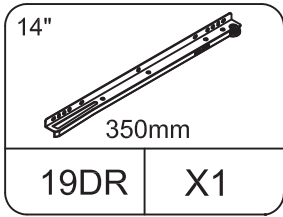

RIGHT DRAWER RUNNER

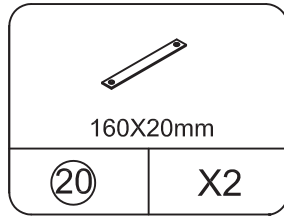

HIPPING RESTRAINT
HARDWARE KIT

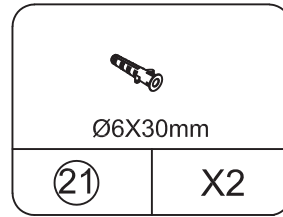

EXPANSION TUBE

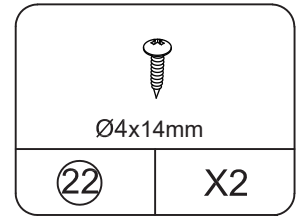

SCREW

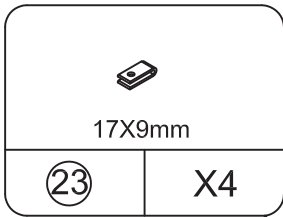

BUCKLES

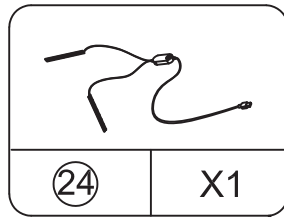

LIGHT BULB

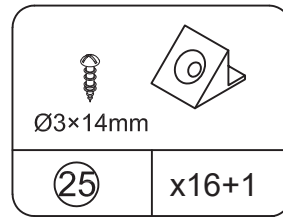

BACK PANEL BUCKLE

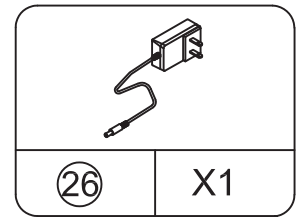

POWER PLUG

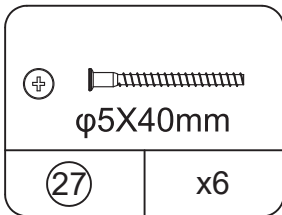

BUCKLES

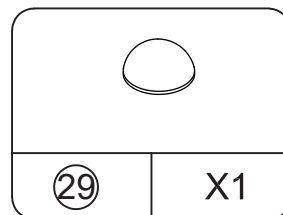
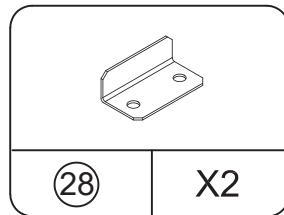

Cam Lock Fastening System

Insert the cam bolt into the hole first, then insert the cam lock and lock it.

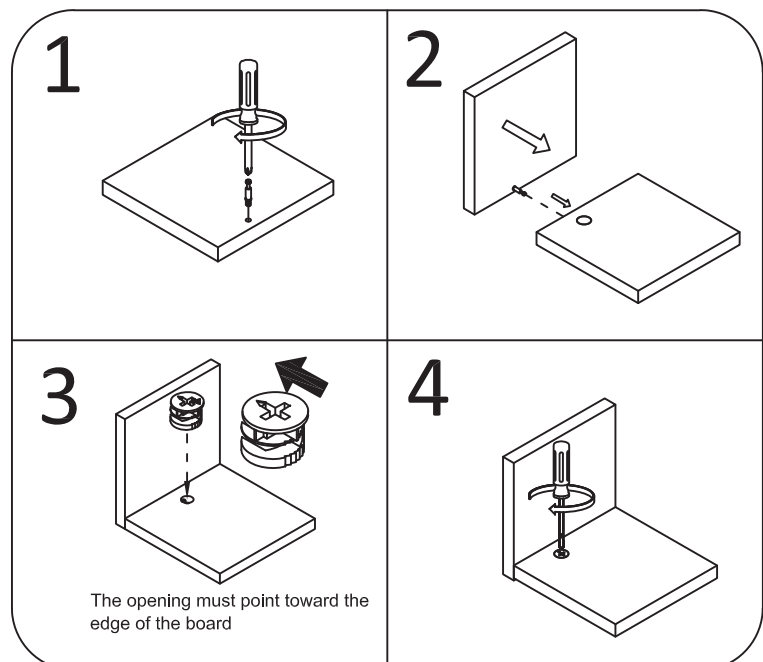

Board Identification

Not actual size

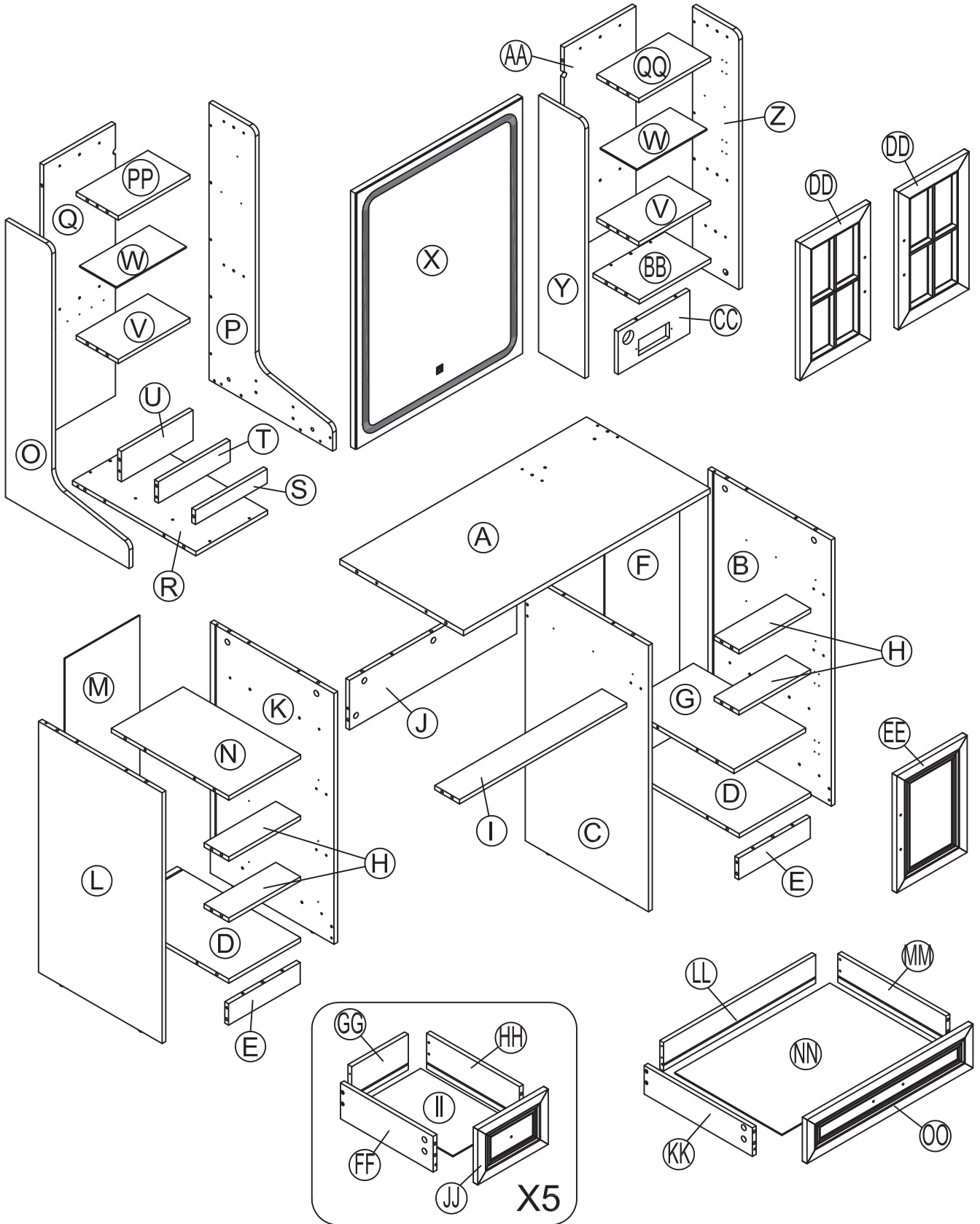

STEP1

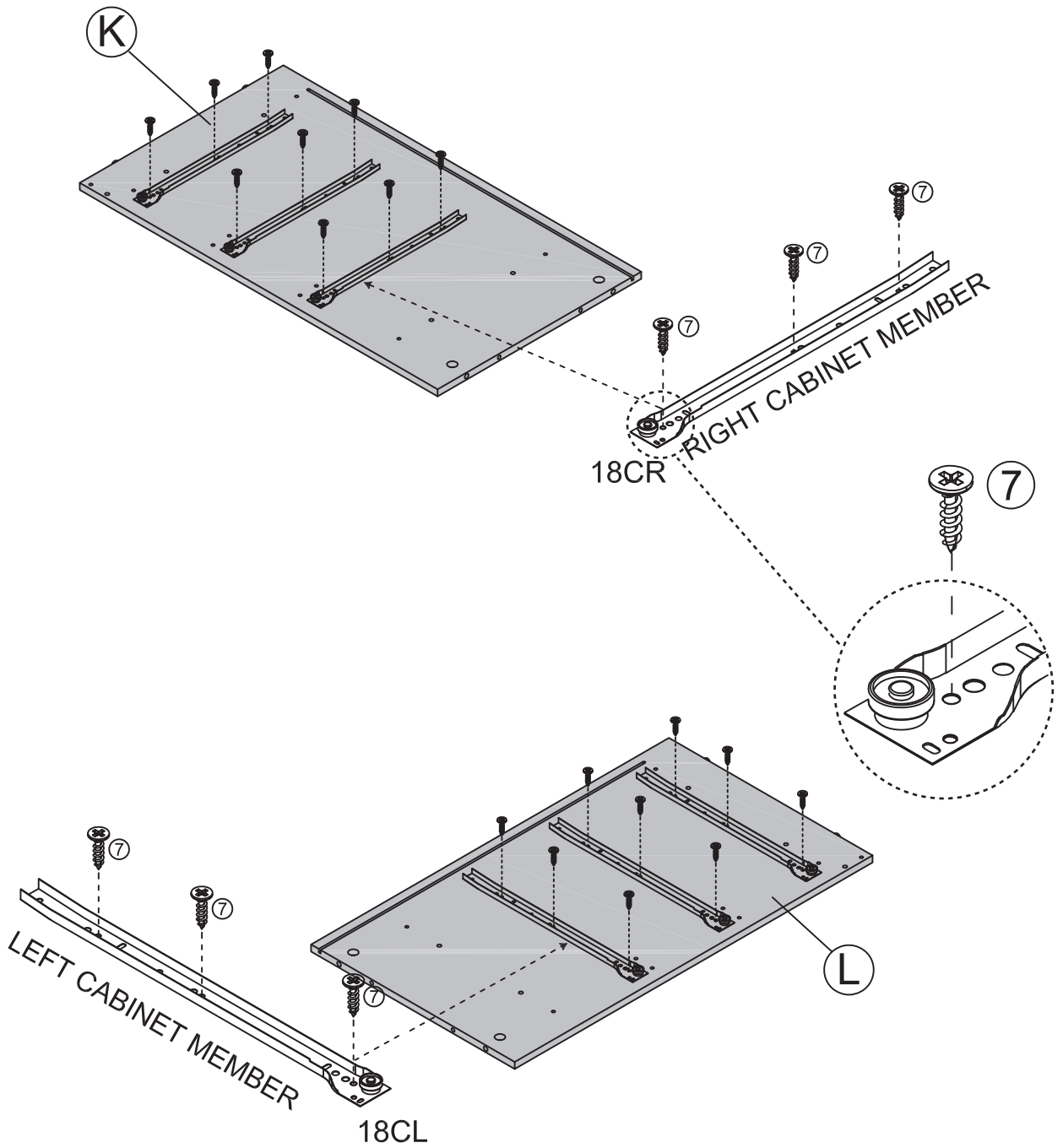
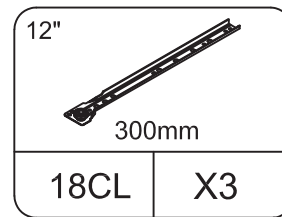
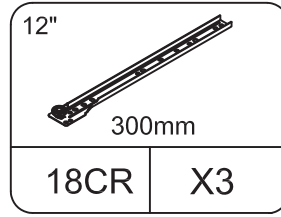
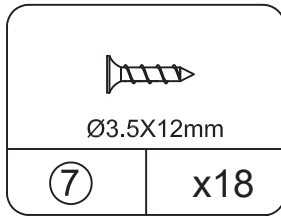

STEP3

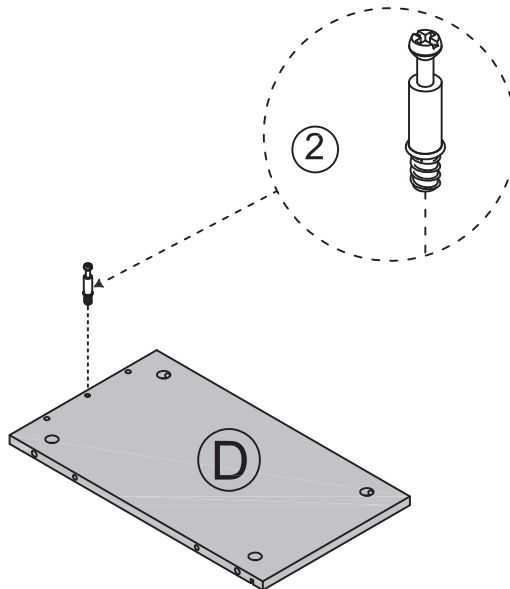
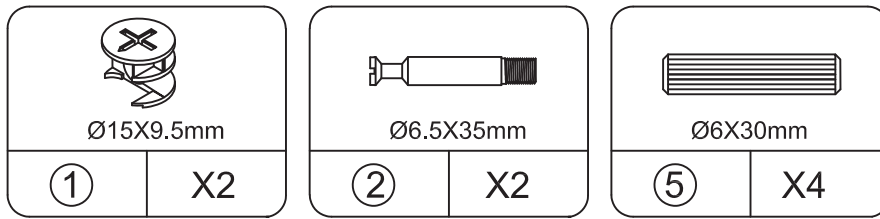

EDGE BANDING

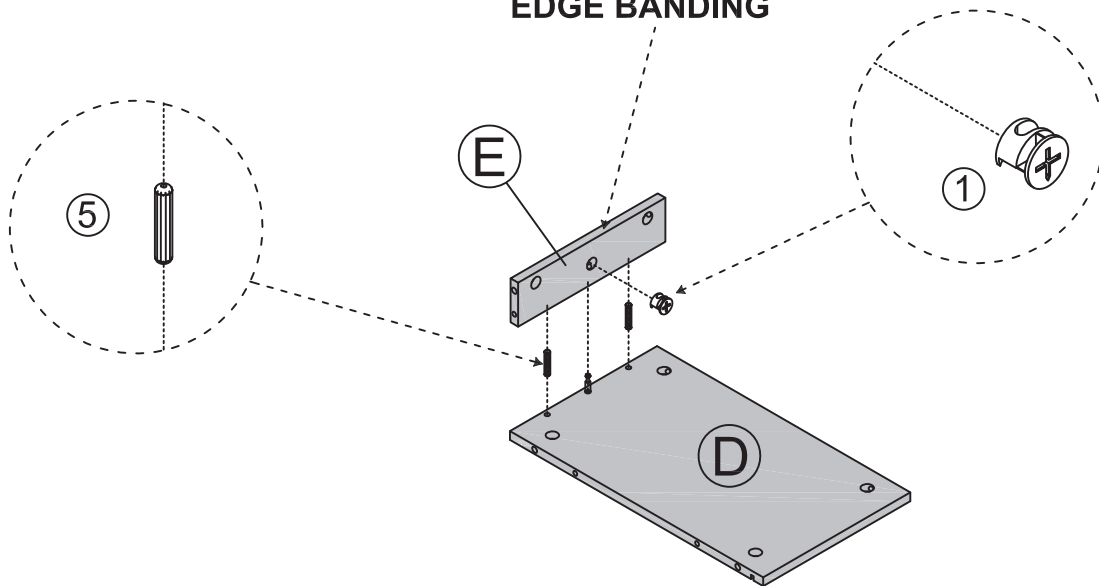

Insert the cam bolt into the hole first, then insert the cam lock and lock it.

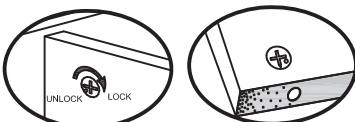

Proper orientation of CAM LOCK

X2

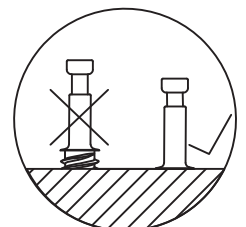

STEP4

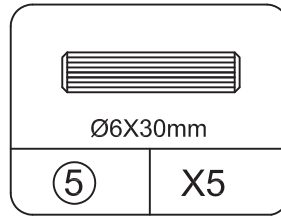
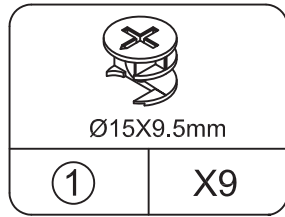

EDGE BANDING

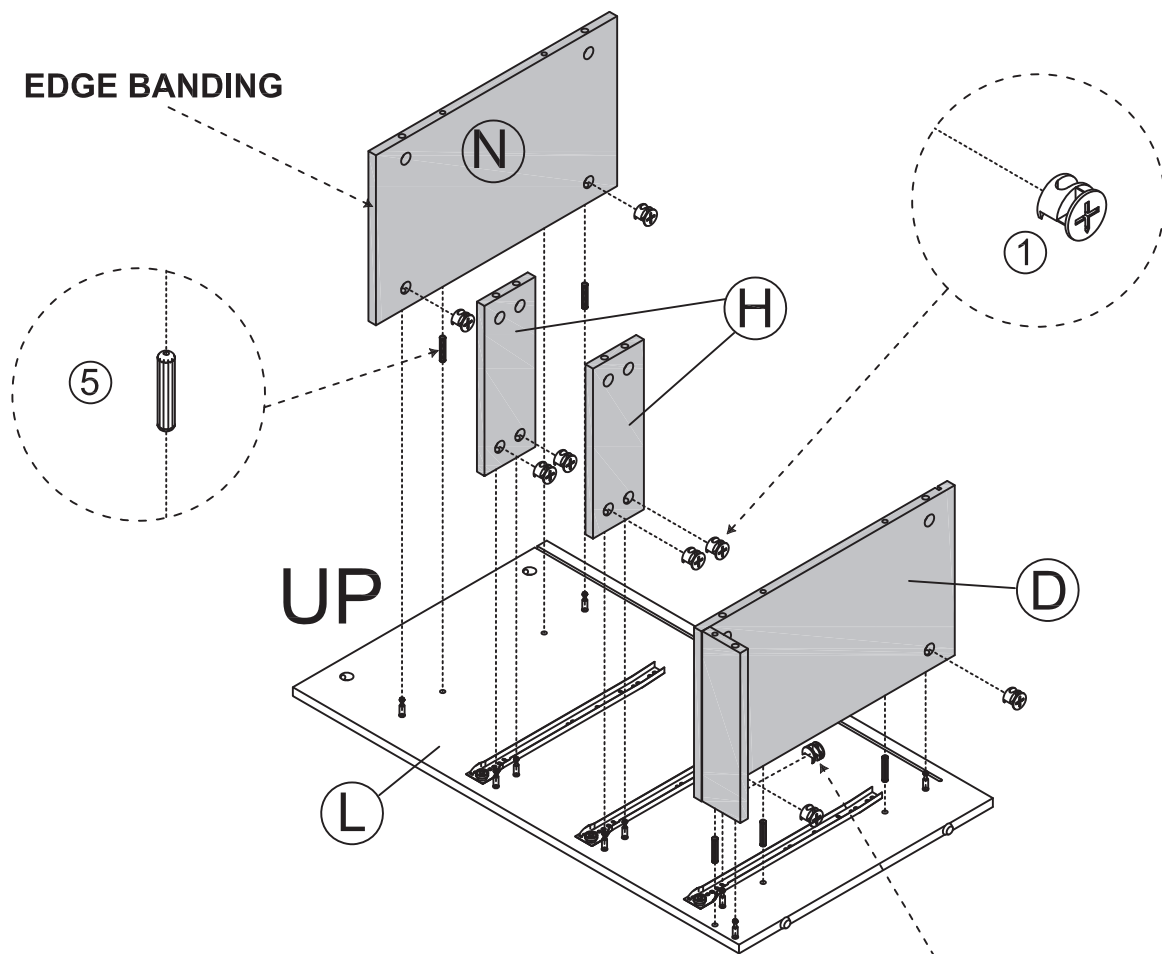

Insert the cam bolt into the hole first, then insert the cam lock and lock it.

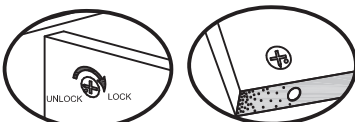

Proper orientation of CAM LOCK

STEP 5

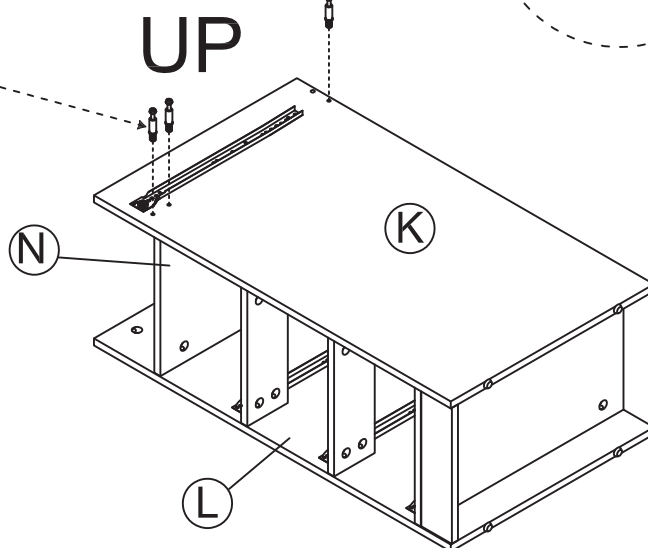
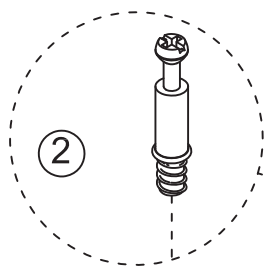
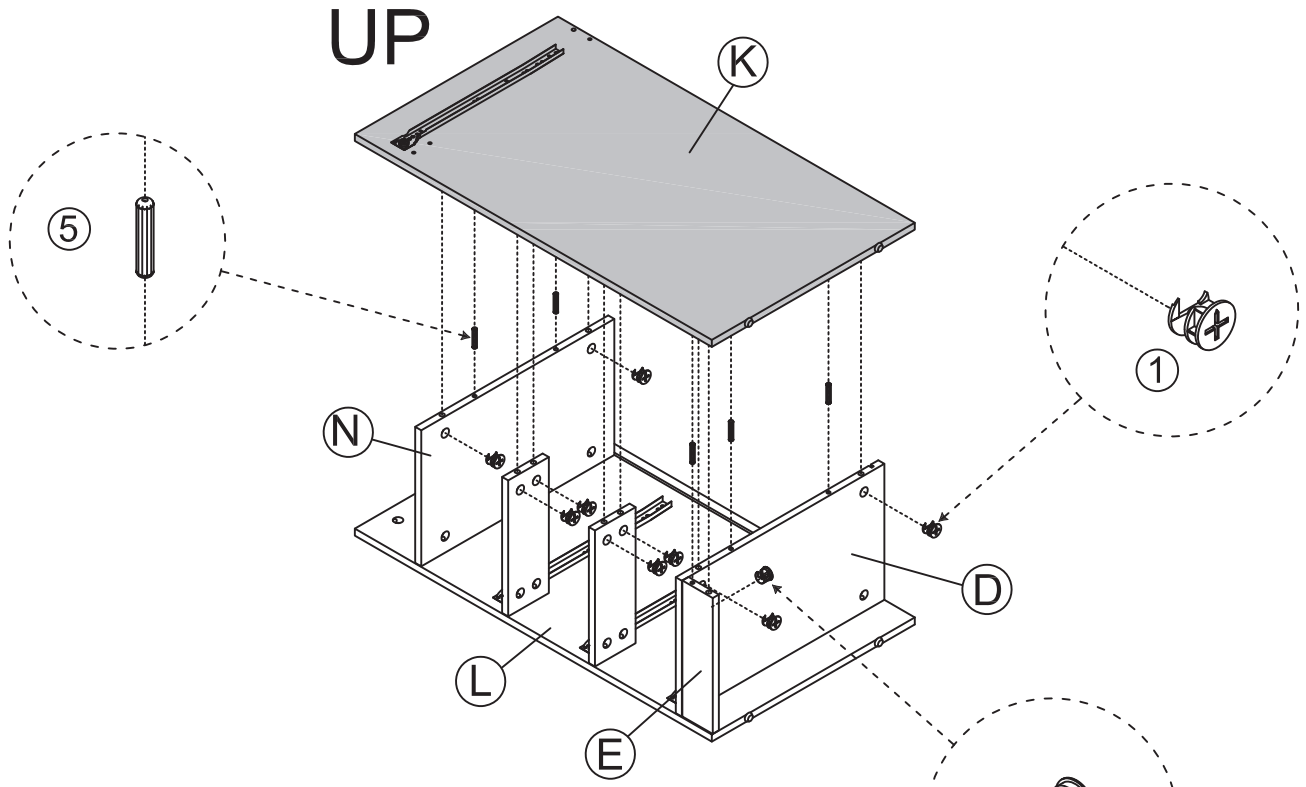
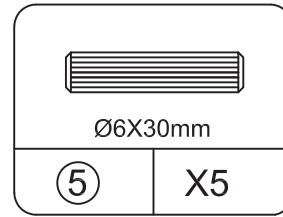
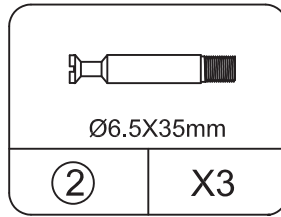
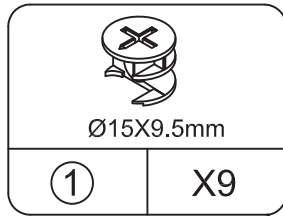

Insert the cam bolt into the hole first, then insert the cam lock and lock it.

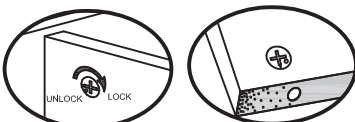

Proper orientation of CAM LOCK

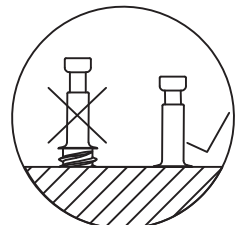

STEP 6

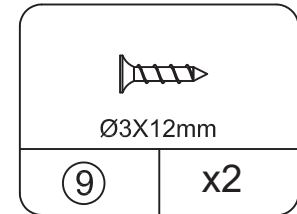
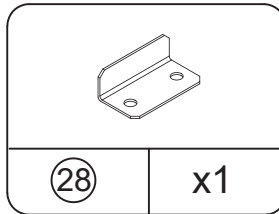
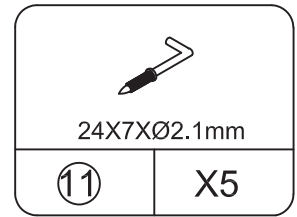
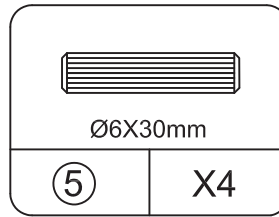
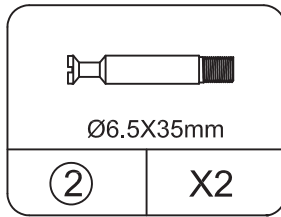
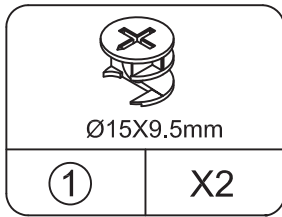

THE RIGHT DIRECTION

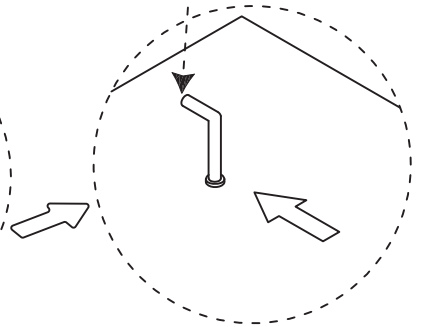
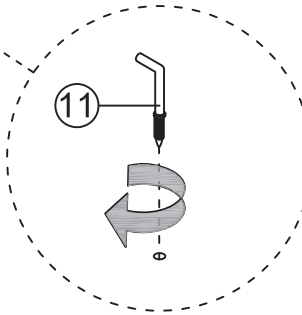
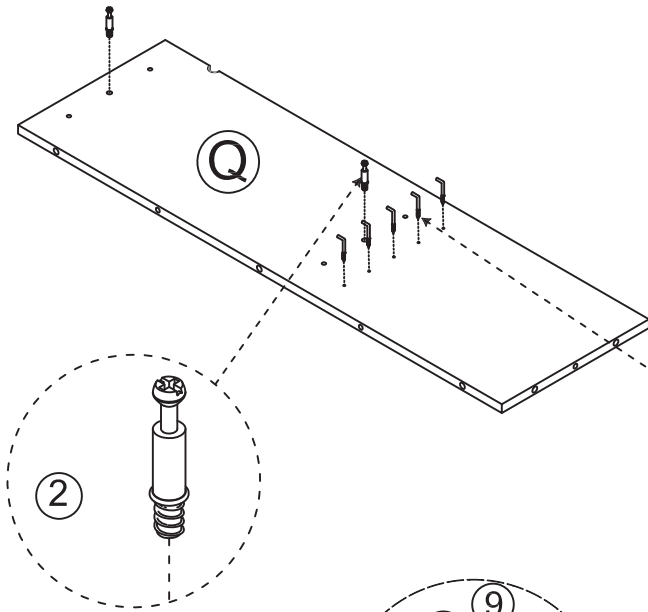

FINISH
No. 11 hardware
completion direction

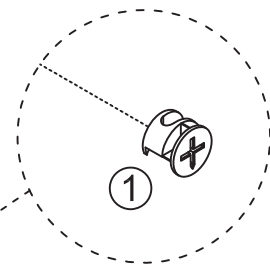
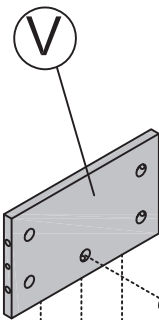
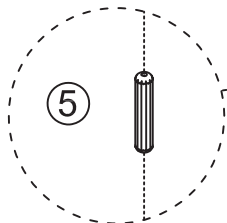
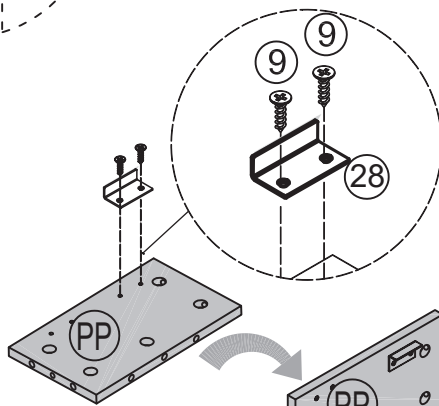

Insert the cam bolt into the hole first, then insert the cam lock and lock it.



Proper orientation of CAM LOCK

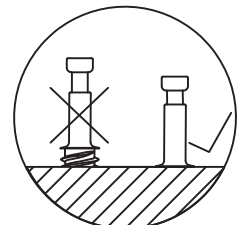

STEP 7

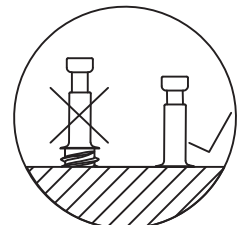
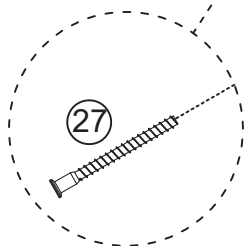
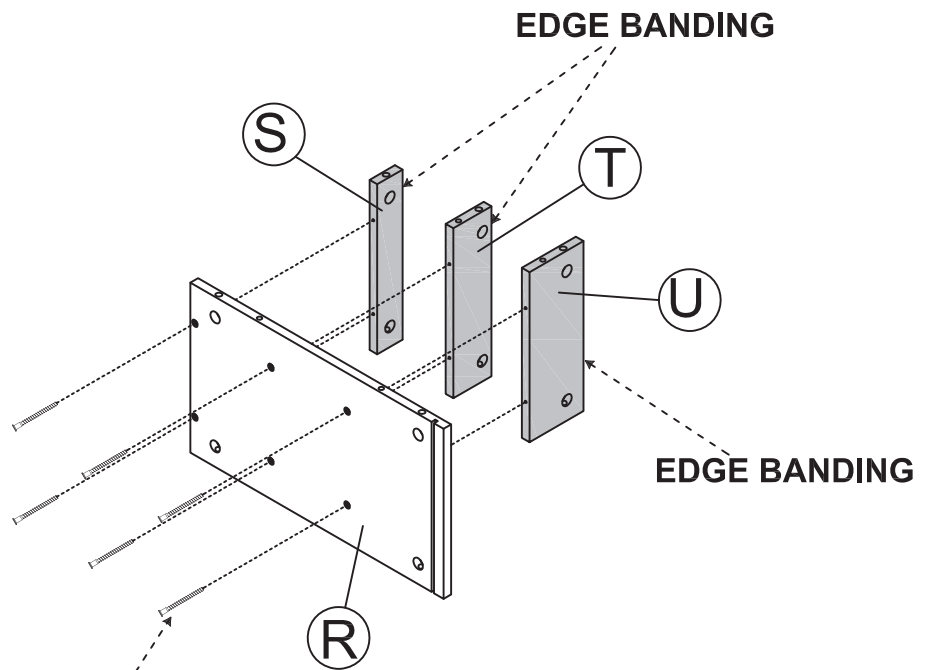
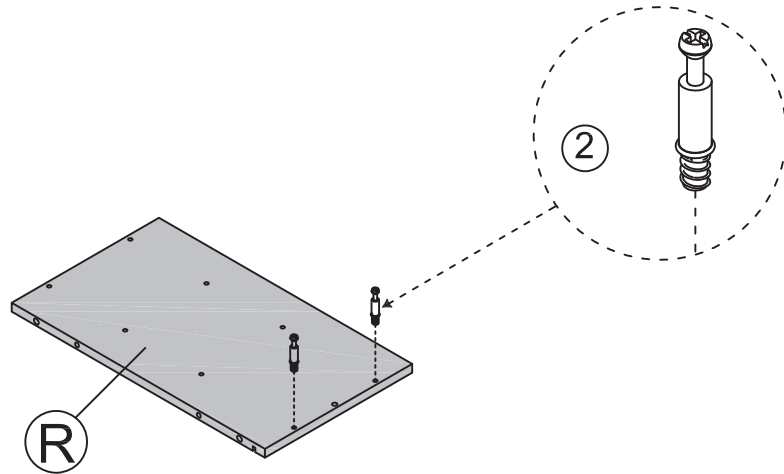
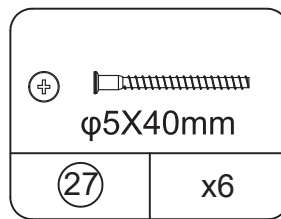
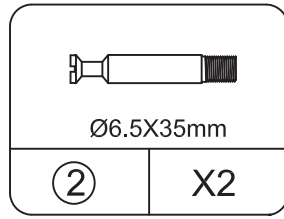

STEP 8

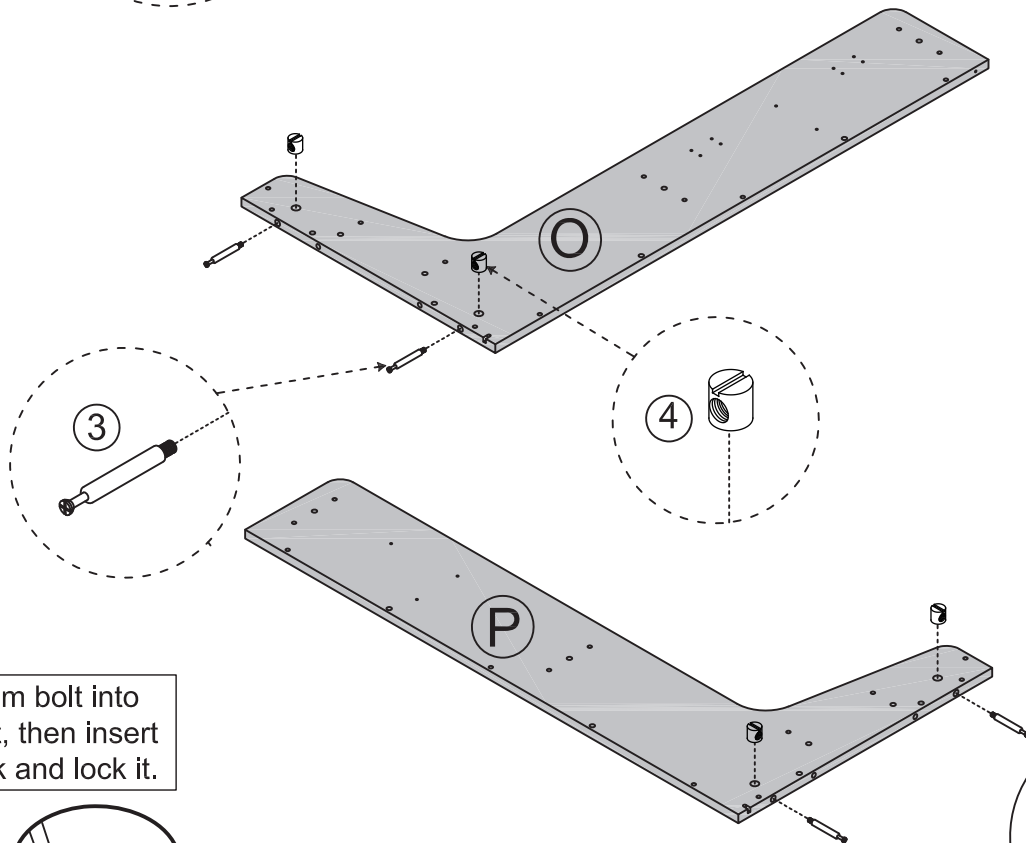
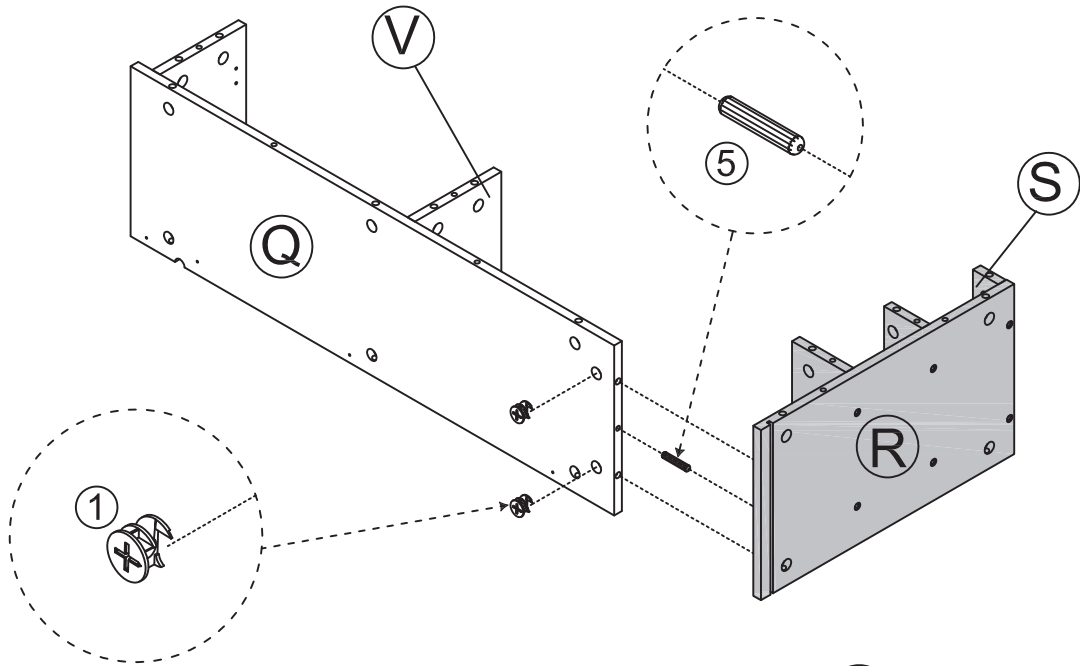
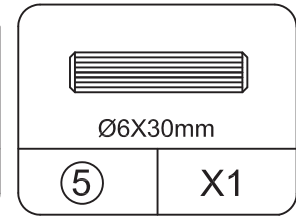
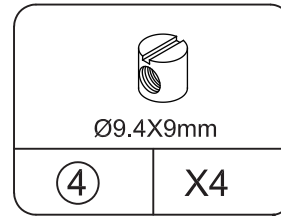
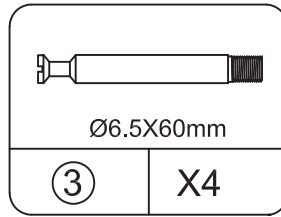
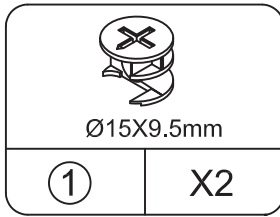

Insert the cam bolt into the hole first, then insert the cam lock and lock it.

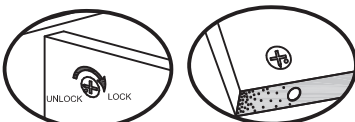

Proper orientation of CAM LOCK

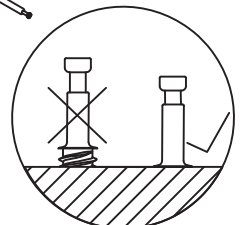

STEP 9

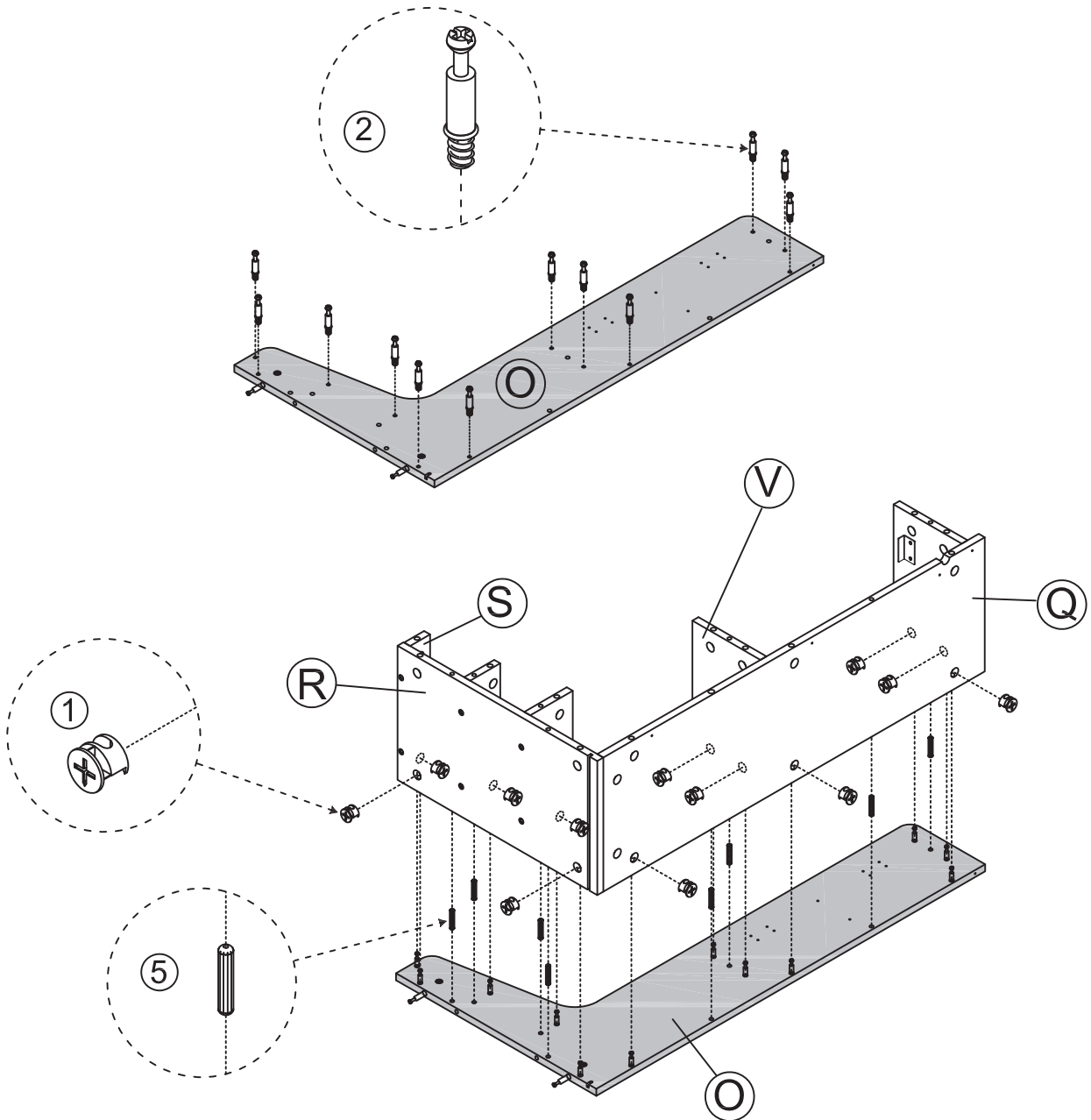
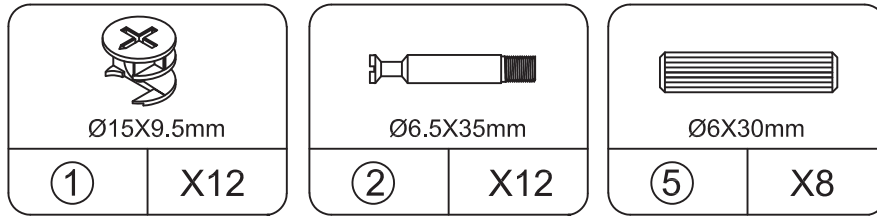

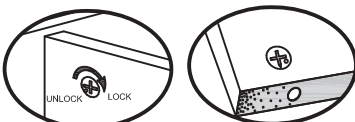

Insert the cam bolt into the hole first, then insert the cam lock and lock it.

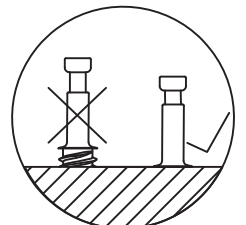

Proper orientation of CAM LOCK



STEP10

 Ø15X9.5mm	 Ø6.5X35mm	 Ø6X30mm
① X12	② X14	⑤ X8

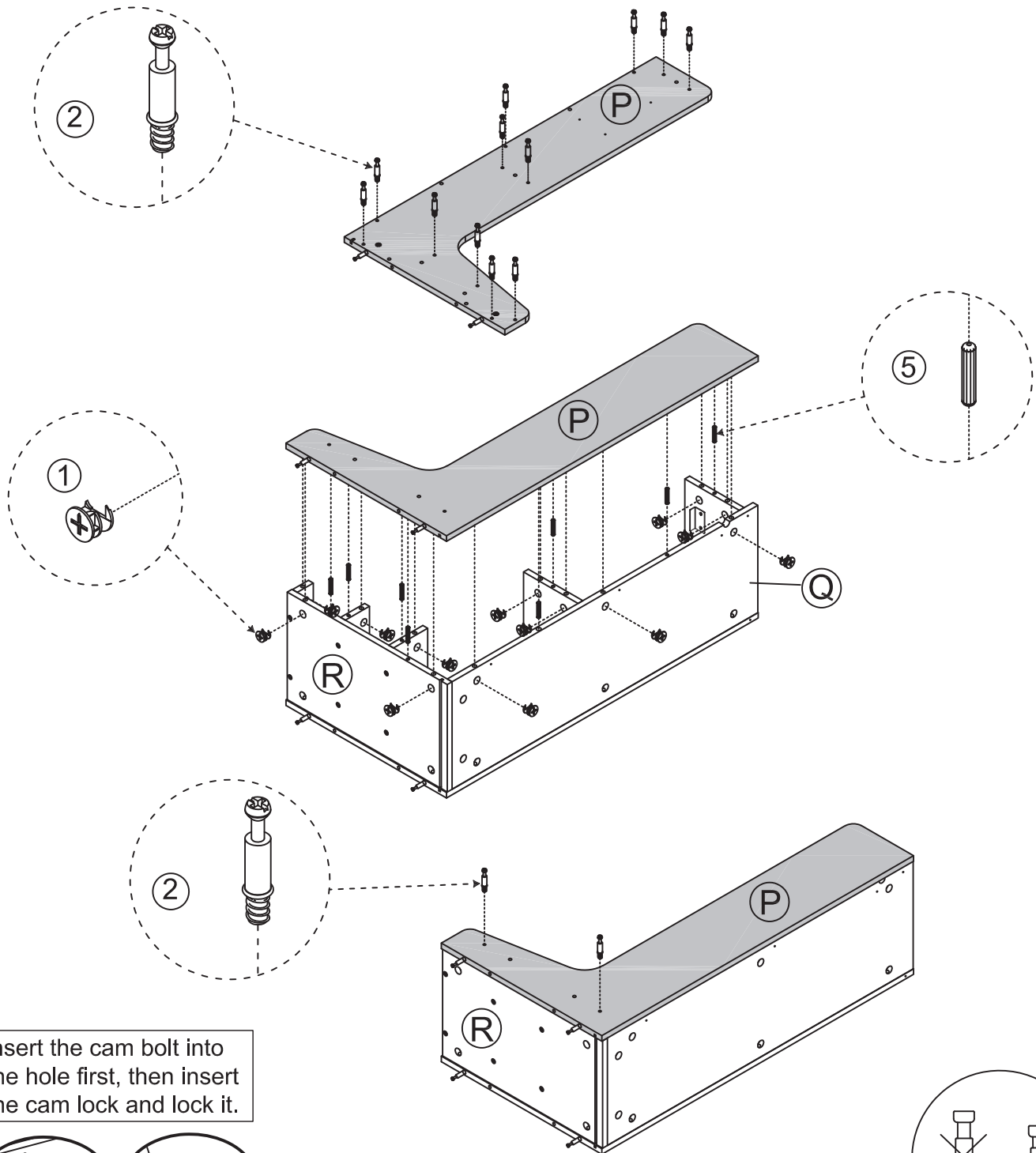

Insert the cam bolt into the hole first, then insert the cam lock and lock it.

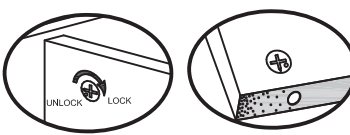

Proper orientation of CAM LOCK

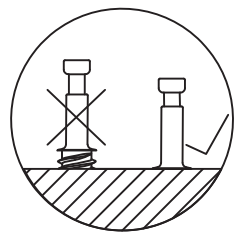

STEP11

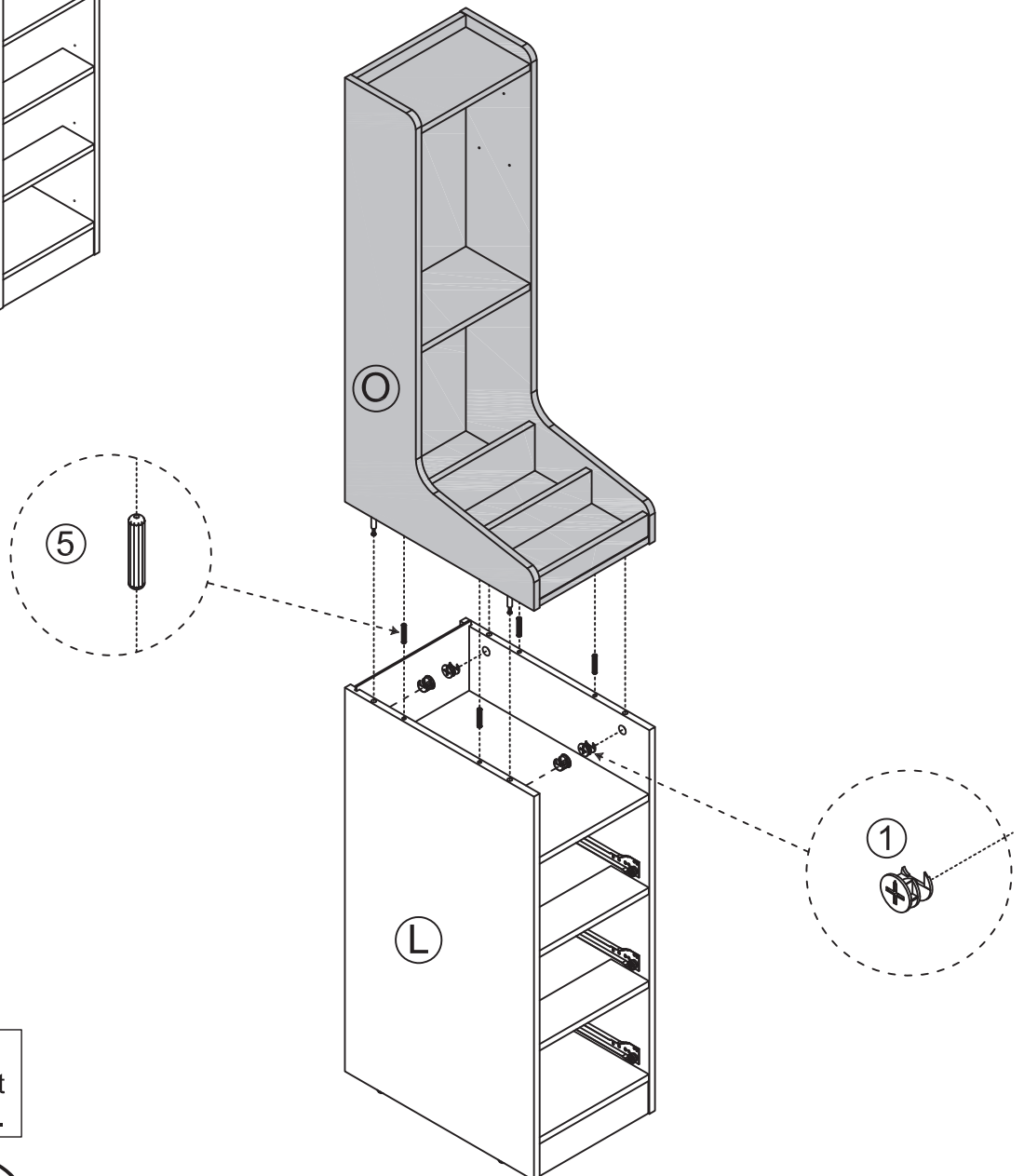
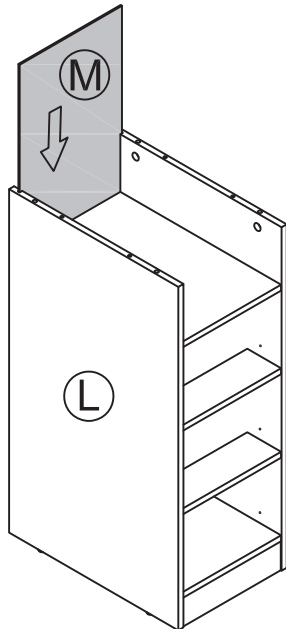
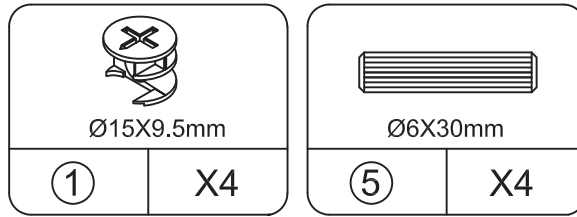

Insert the cam bolt into the hole first, then insert the cam lock and lock it.

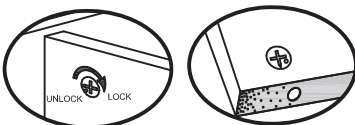

Proper orientation of CAM LOCK

STEP12

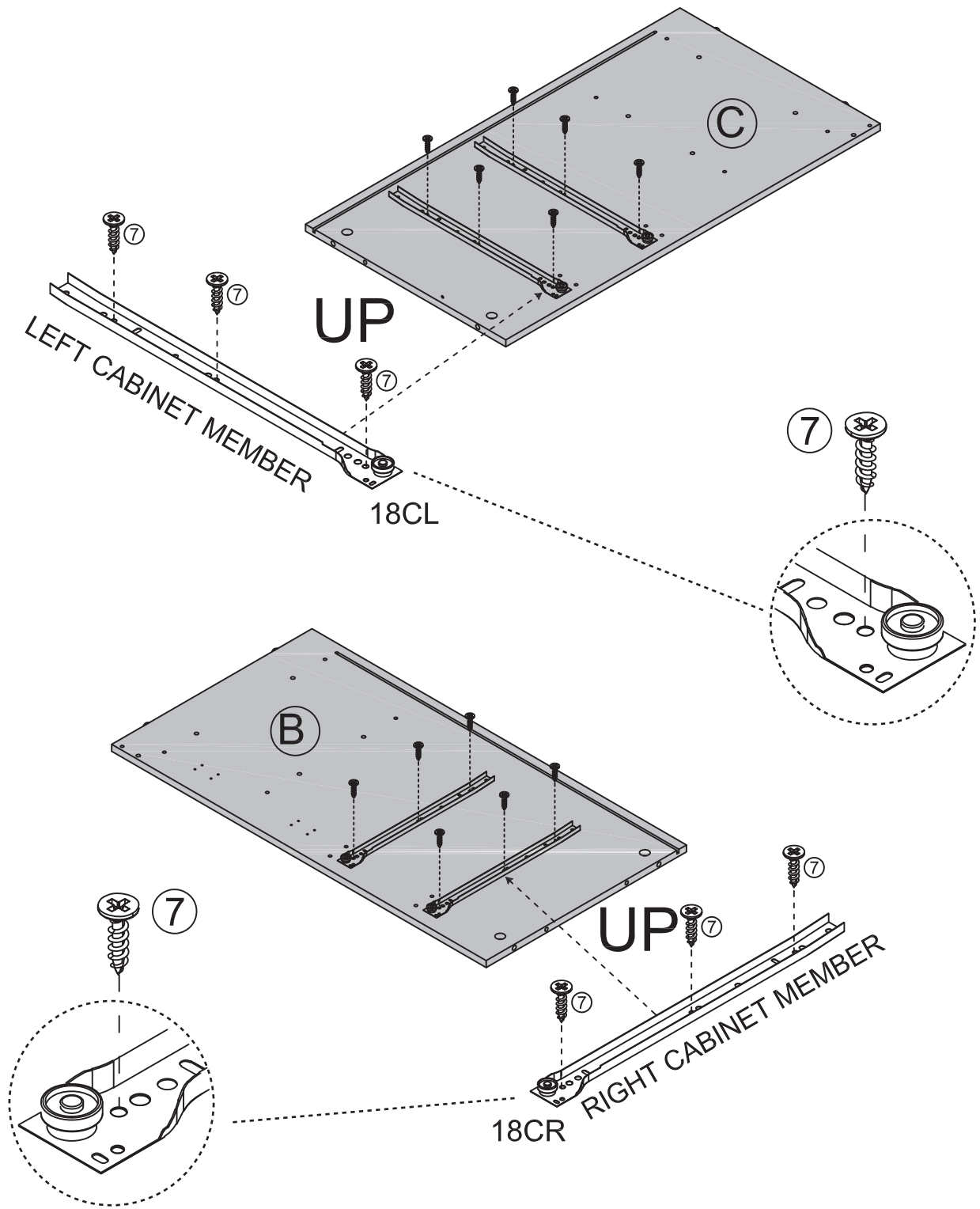
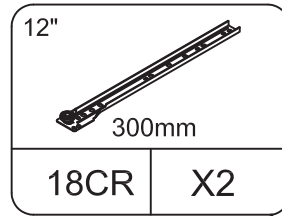
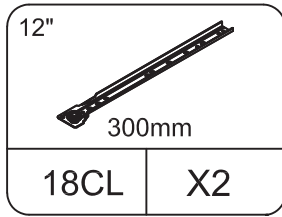
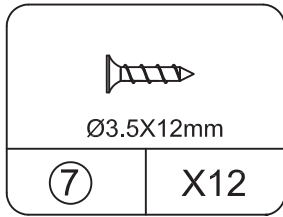

STEP13

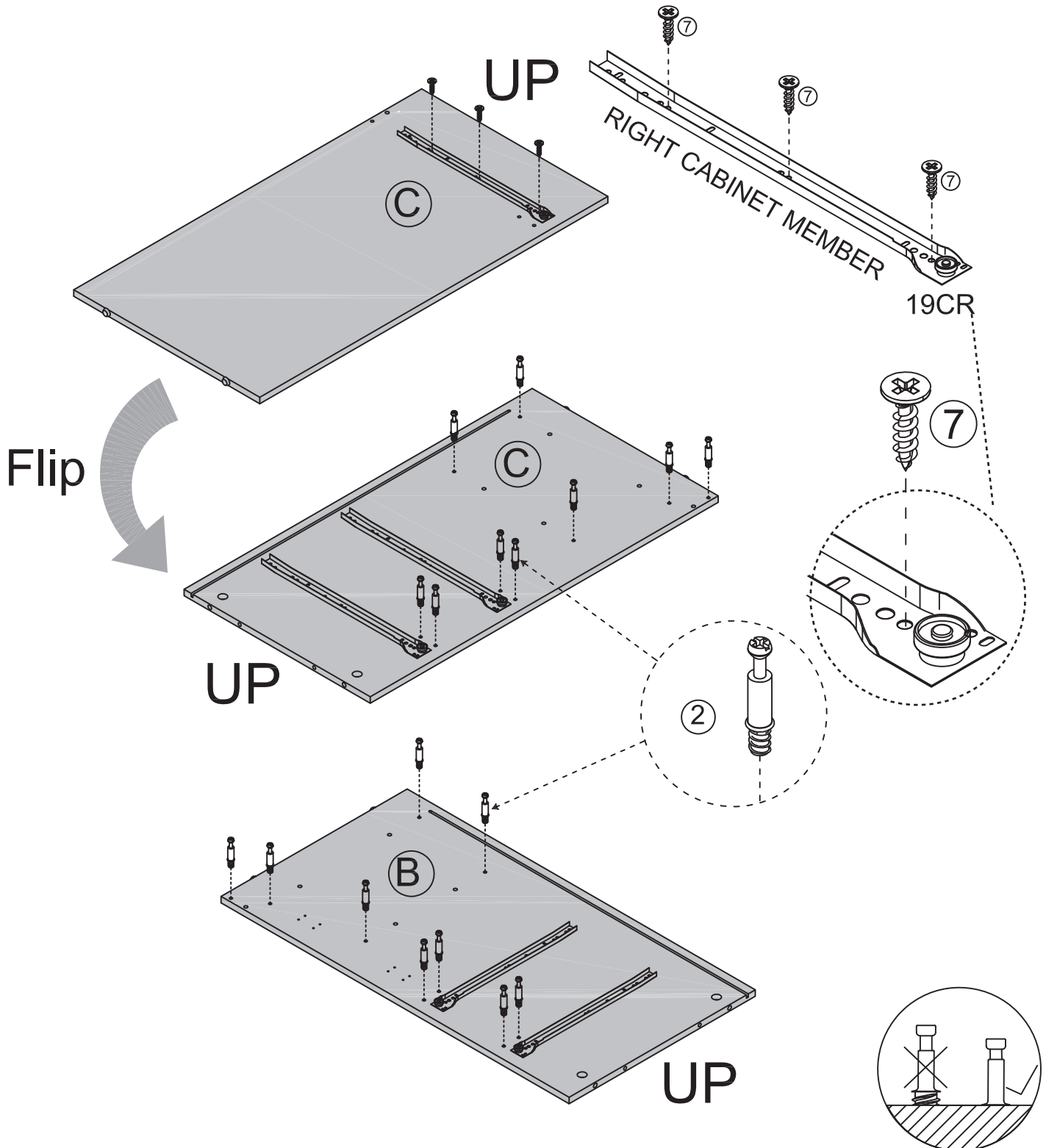
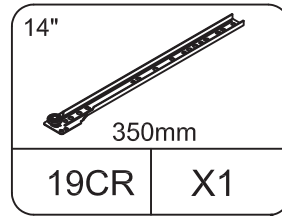
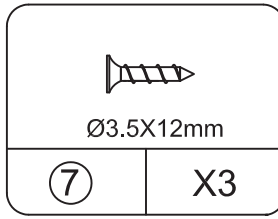
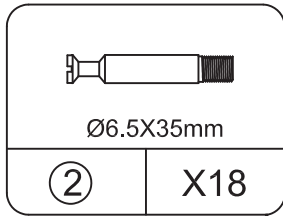

STEP14

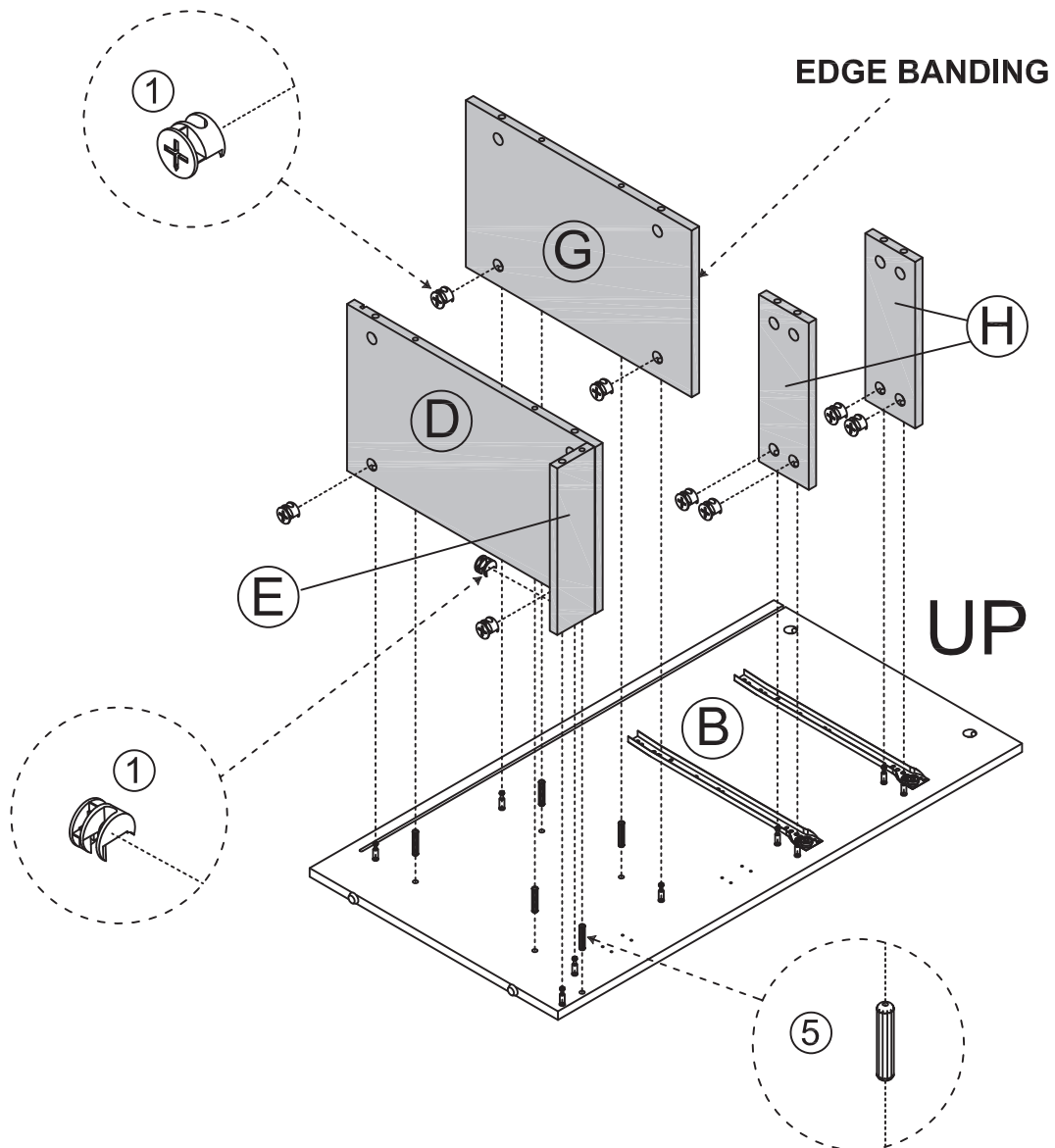
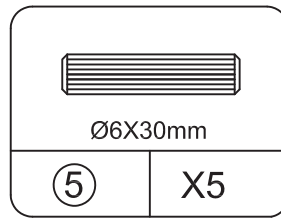
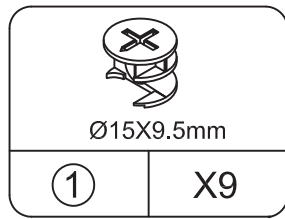

Insert the cam bolt into the hole first, then insert the cam lock and lock it.

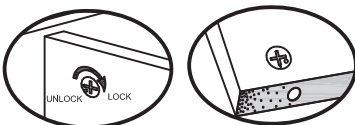

Proper orientation of CAM LOCK

STEP15

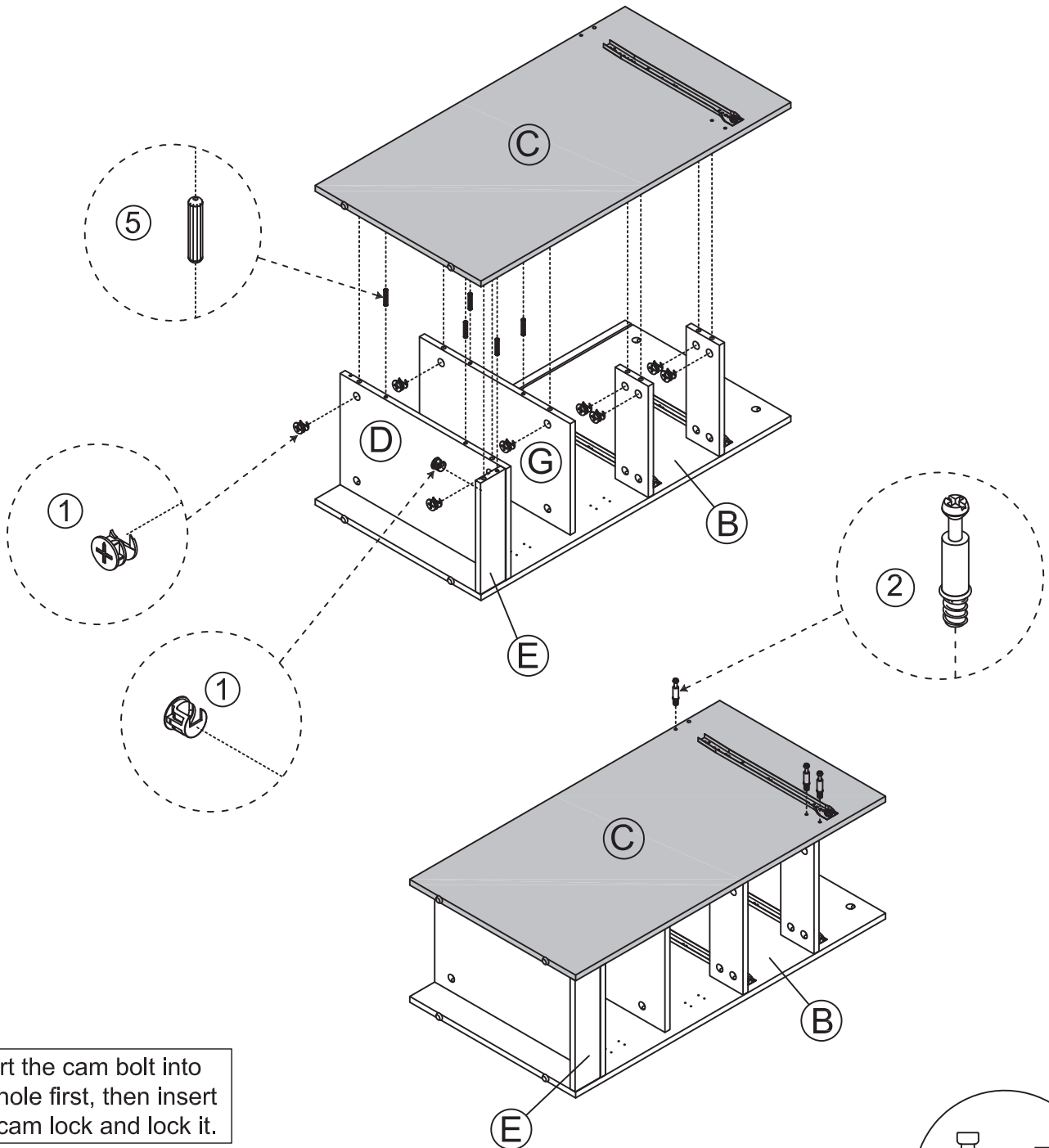
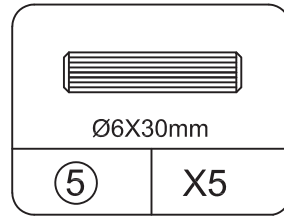
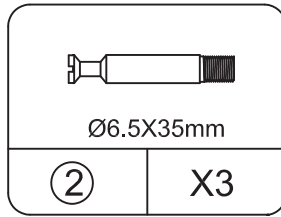
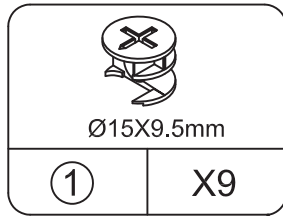

Insert the cam bolt into the hole first, then insert the cam lock and lock it.

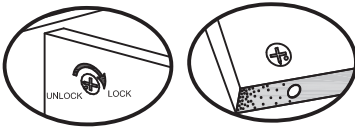

Proper orientation of CAM LOCK

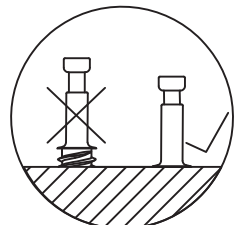

STEP16

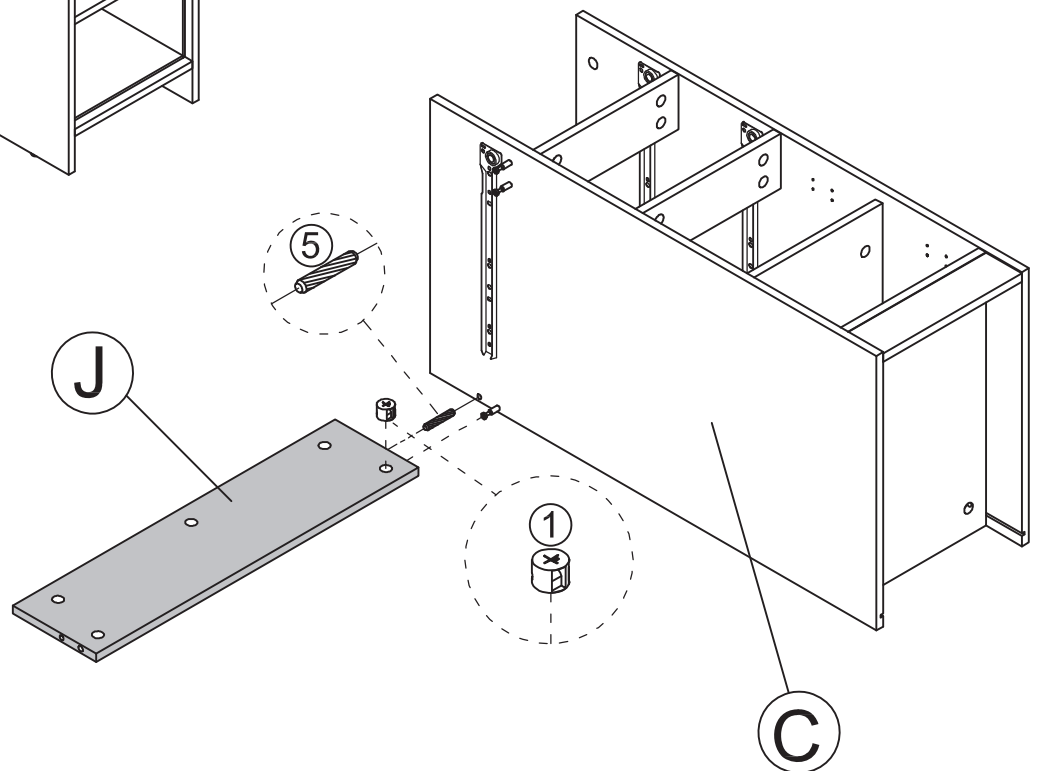
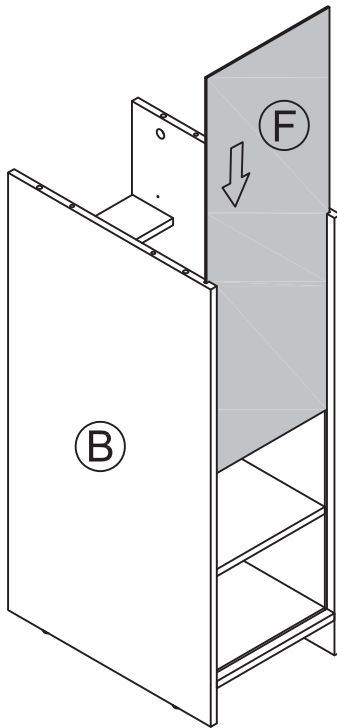
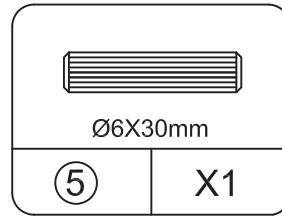
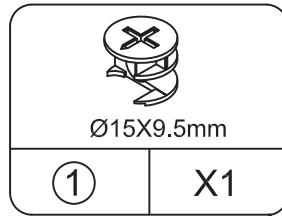

Insert the cam bolt into the hole first, then insert the cam lock and lock it.

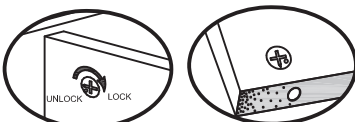

Proper orientation of CAM LOCK

STEP17

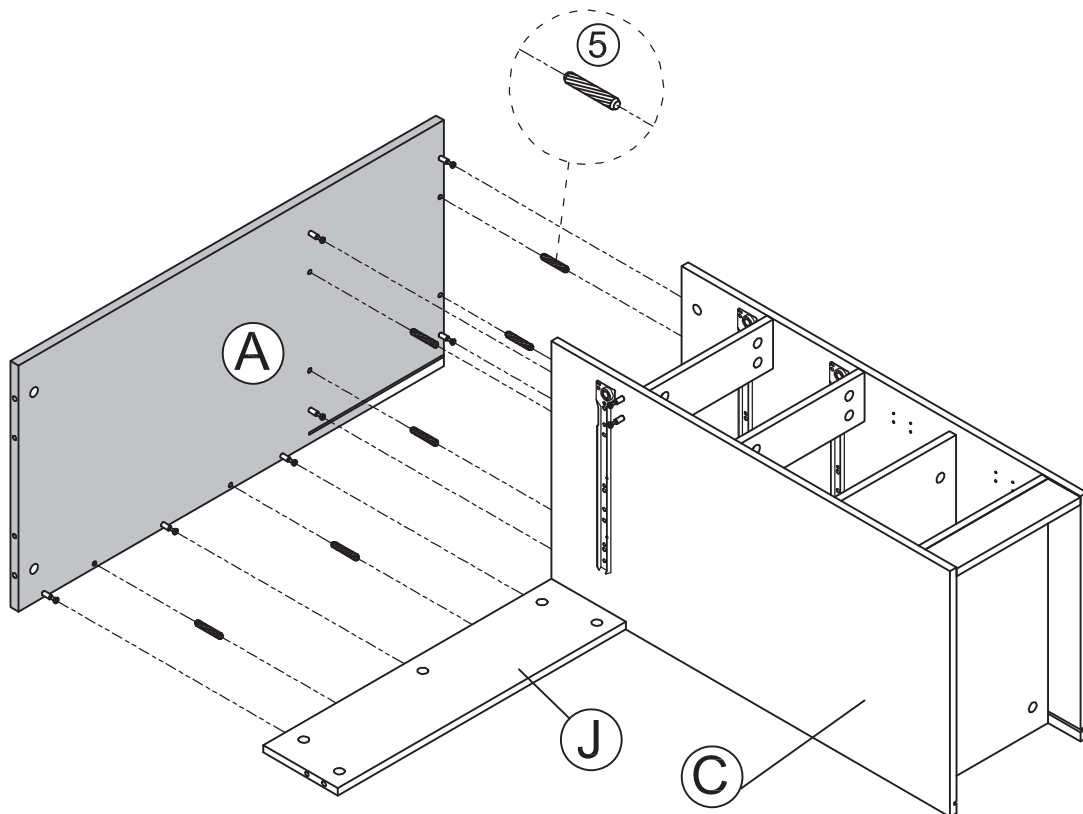
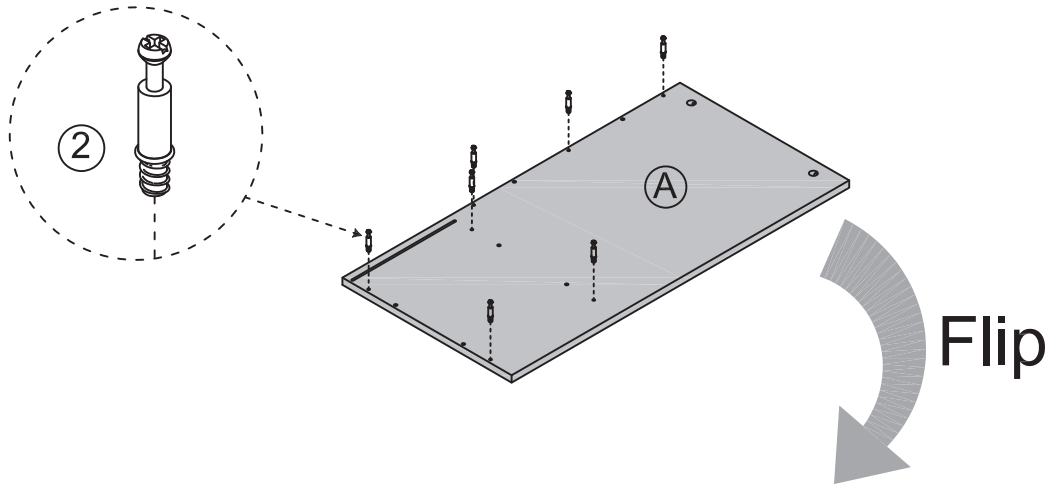
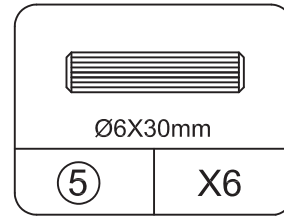
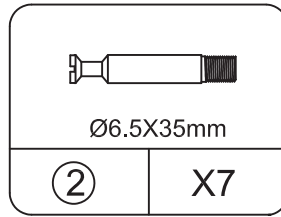

Insert the cam bolt into the hole first, then insert the cam lock and lock it.



Proper orientation of CAM LOCK

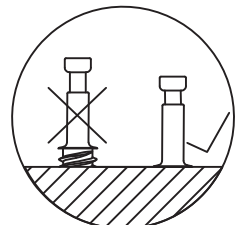

STEP18

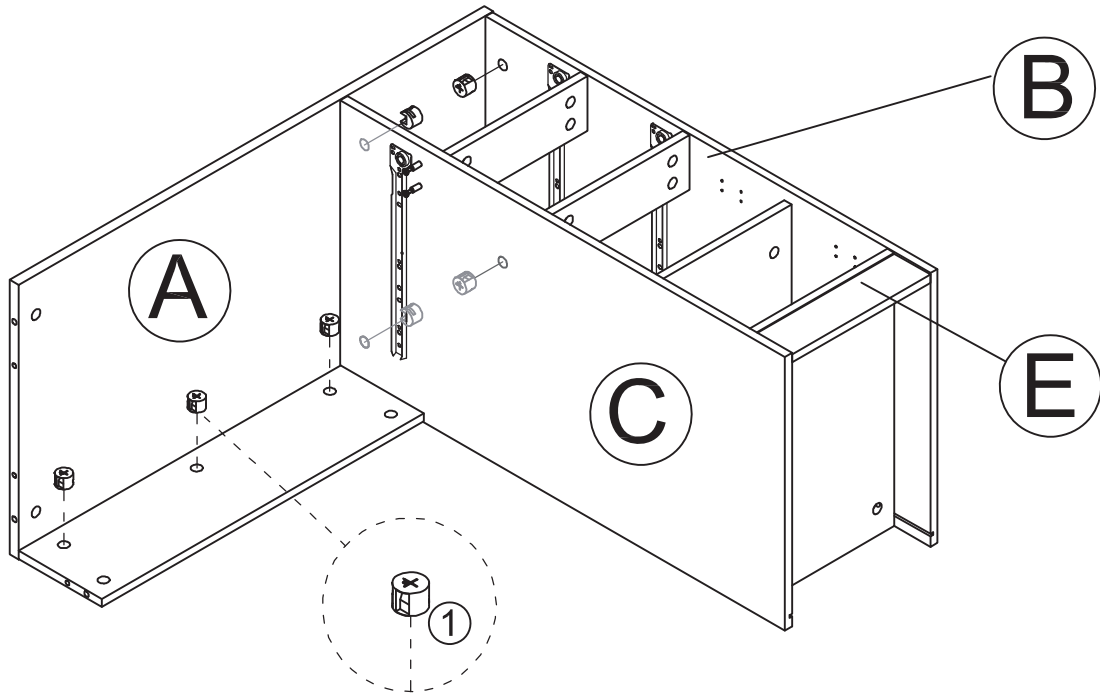
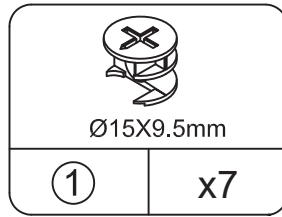

Insert the cam bolt into the hole first, then insert the cam lock and lock it.

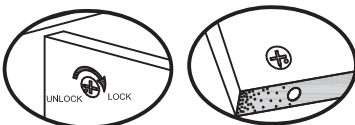

Proper orientation of CAM LOCK

STEP19

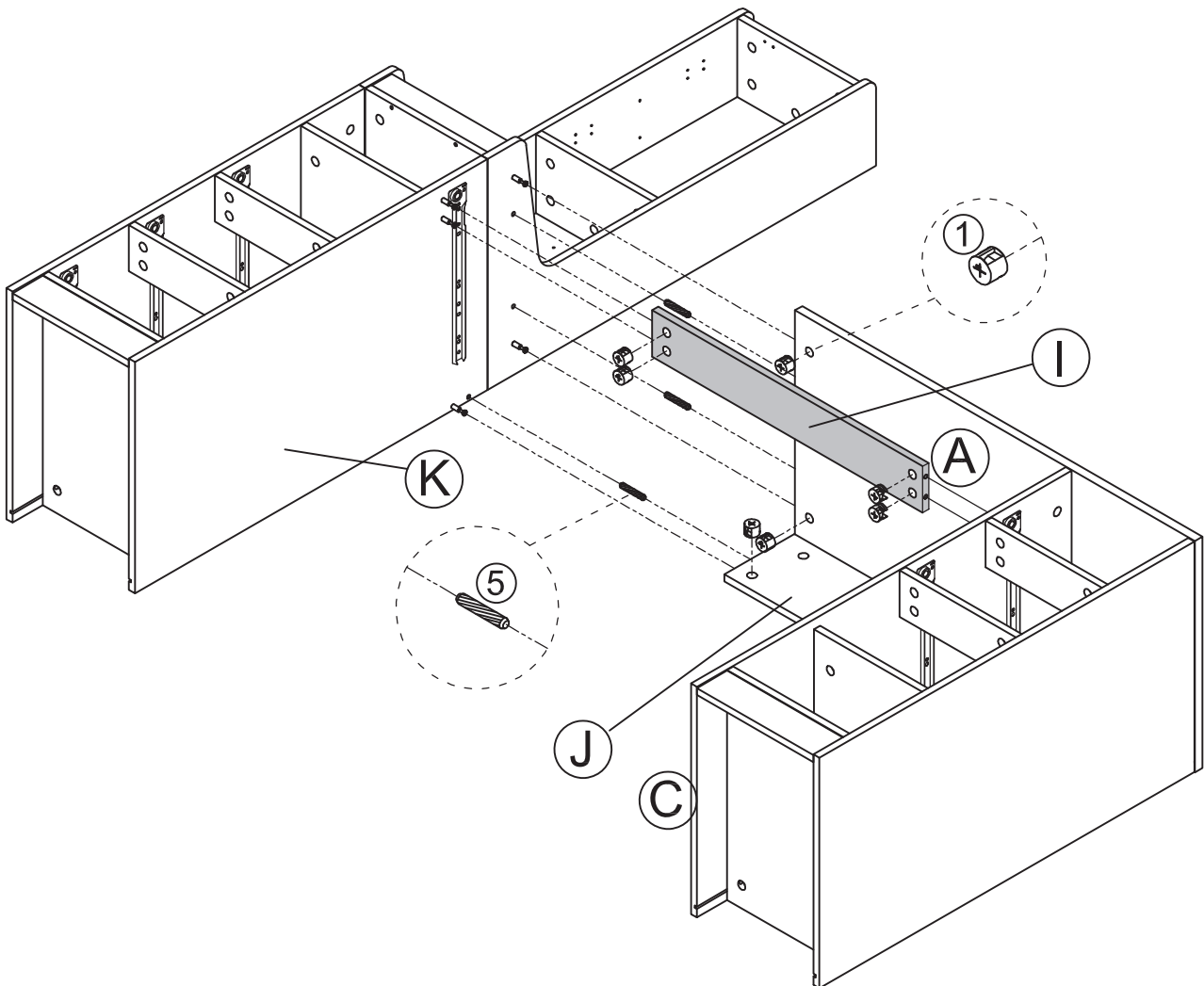
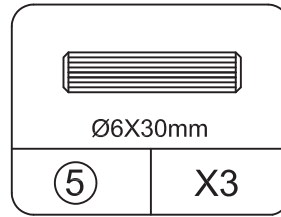
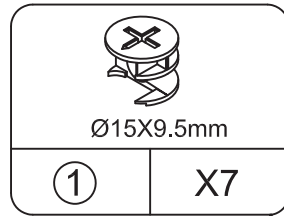

Insert the cam bolt into the hole first, then insert the cam lock and lock it.

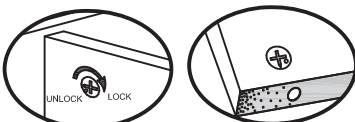

Proper orientation of CAM LOCK

STEP20



Ø15X9.5mm

①	X2
---	----

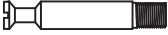

Ø6.5X35mm

②	X2
---	----



Ø6X30mm

⑤	X4
---	----

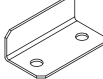

②⑧	x1
----	----



Ø3X12mm

⑨	x2
---	----

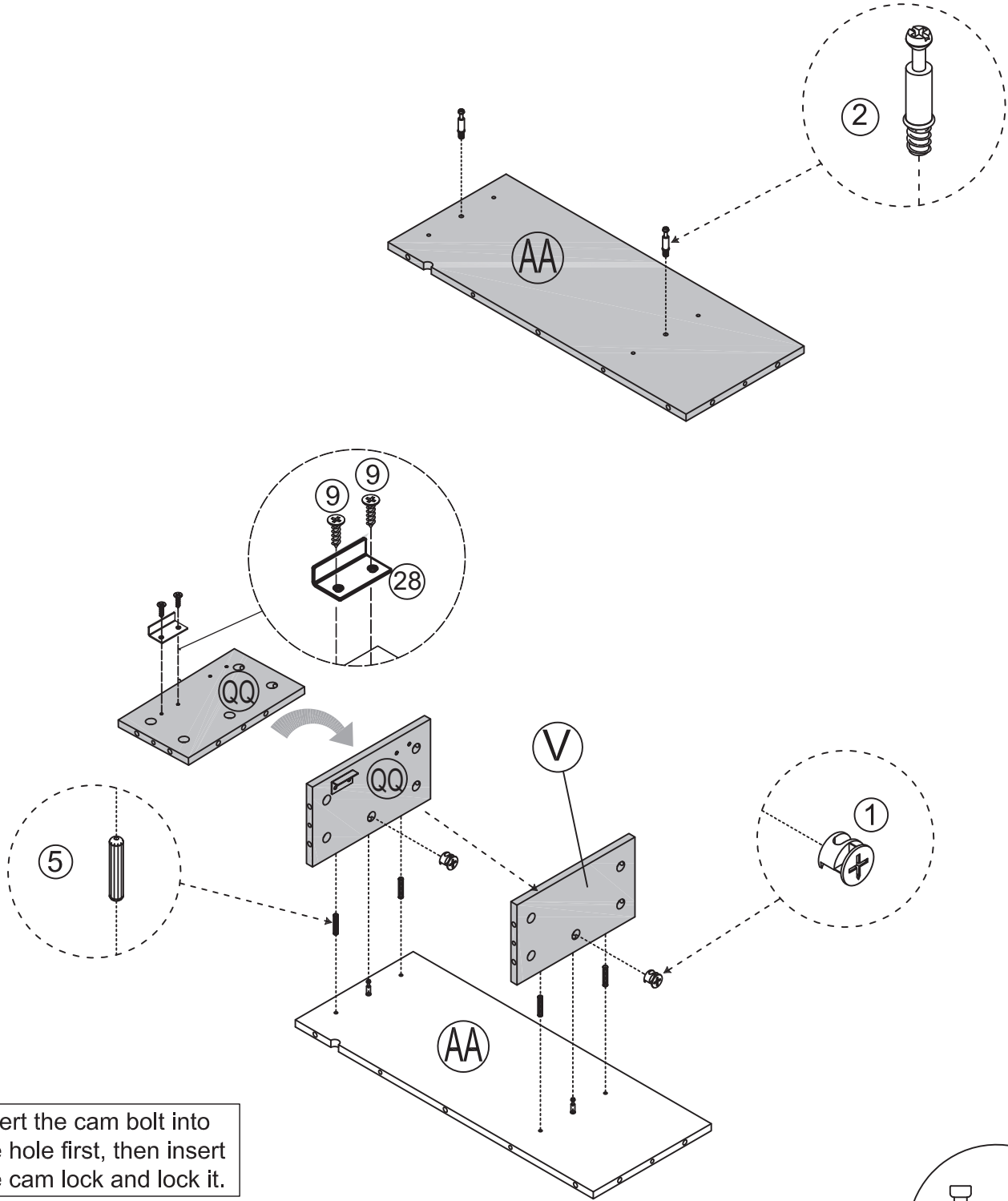

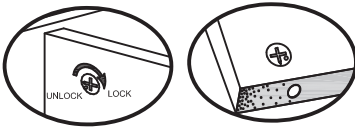

Insert the cam bolt into the hole first, then insert the cam lock and lock it.

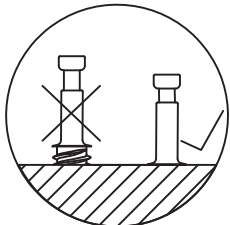

Proper orientation of CAM LOCK

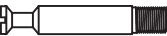

STEP21

 Ø15X9.5mm	 Ø6.5X35mm	 Ø6X30mm
① X2	② X2	⑤ X1

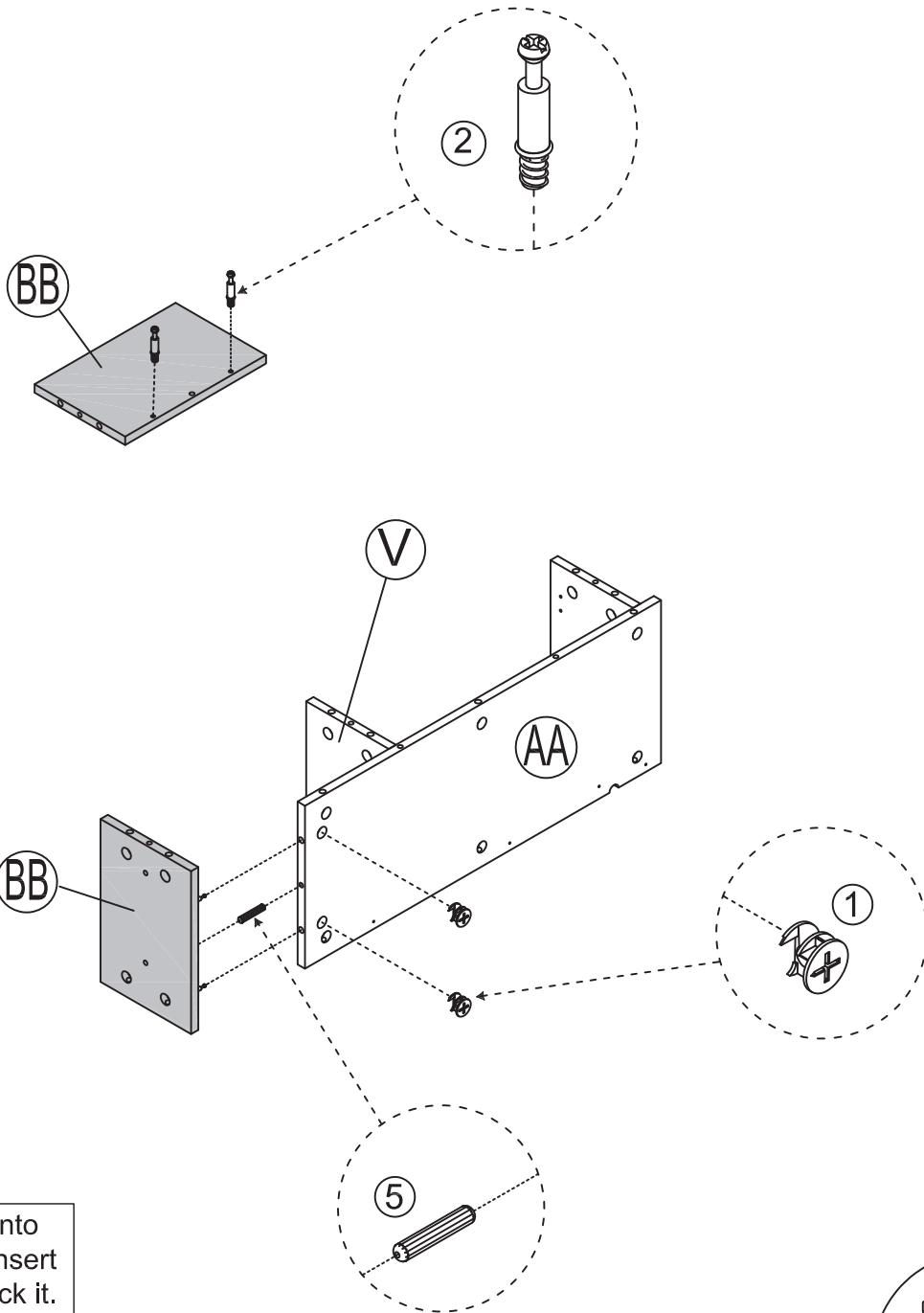

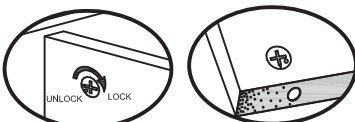

Insert the cam bolt into the hole first, then insert the cam lock and lock it.

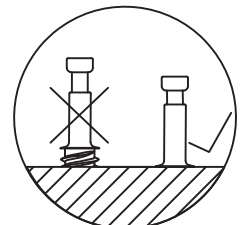

Proper orientation of CAM LOCK



STEP22

 Ø15X9.5mm		 Ø6.5X35mm		 Ø6X30mm	
①	X6	②	X9	⑤	X5

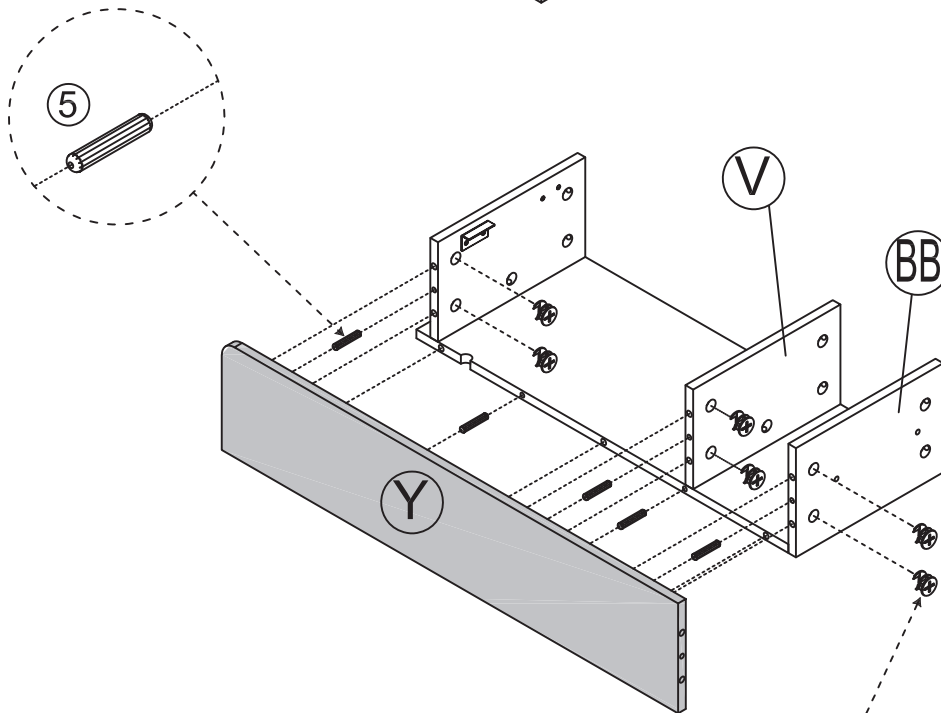
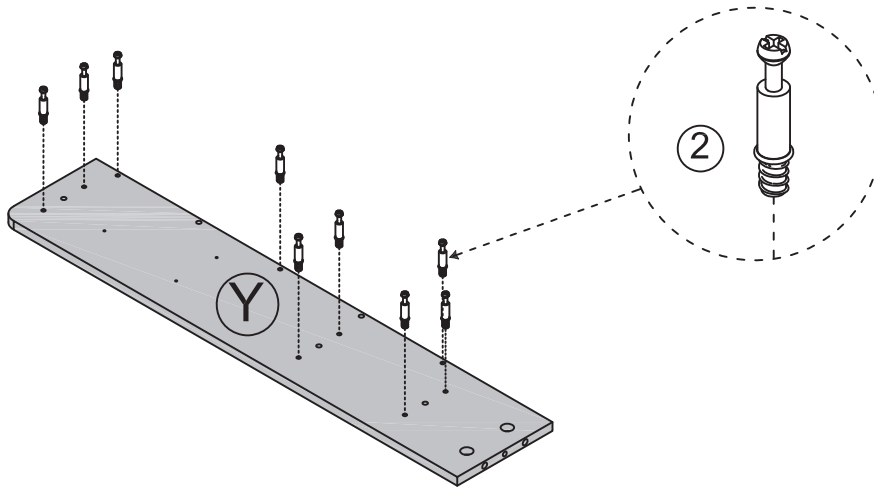

Insert the cam bolt into the hole first, then insert the cam lock and lock it.

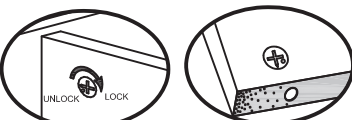

Proper orientation of CAM LOCK

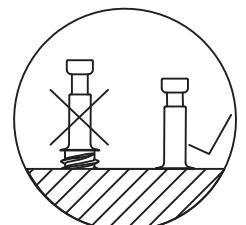
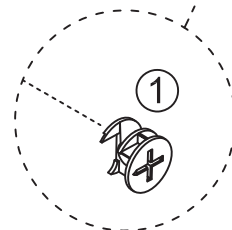

STEP23

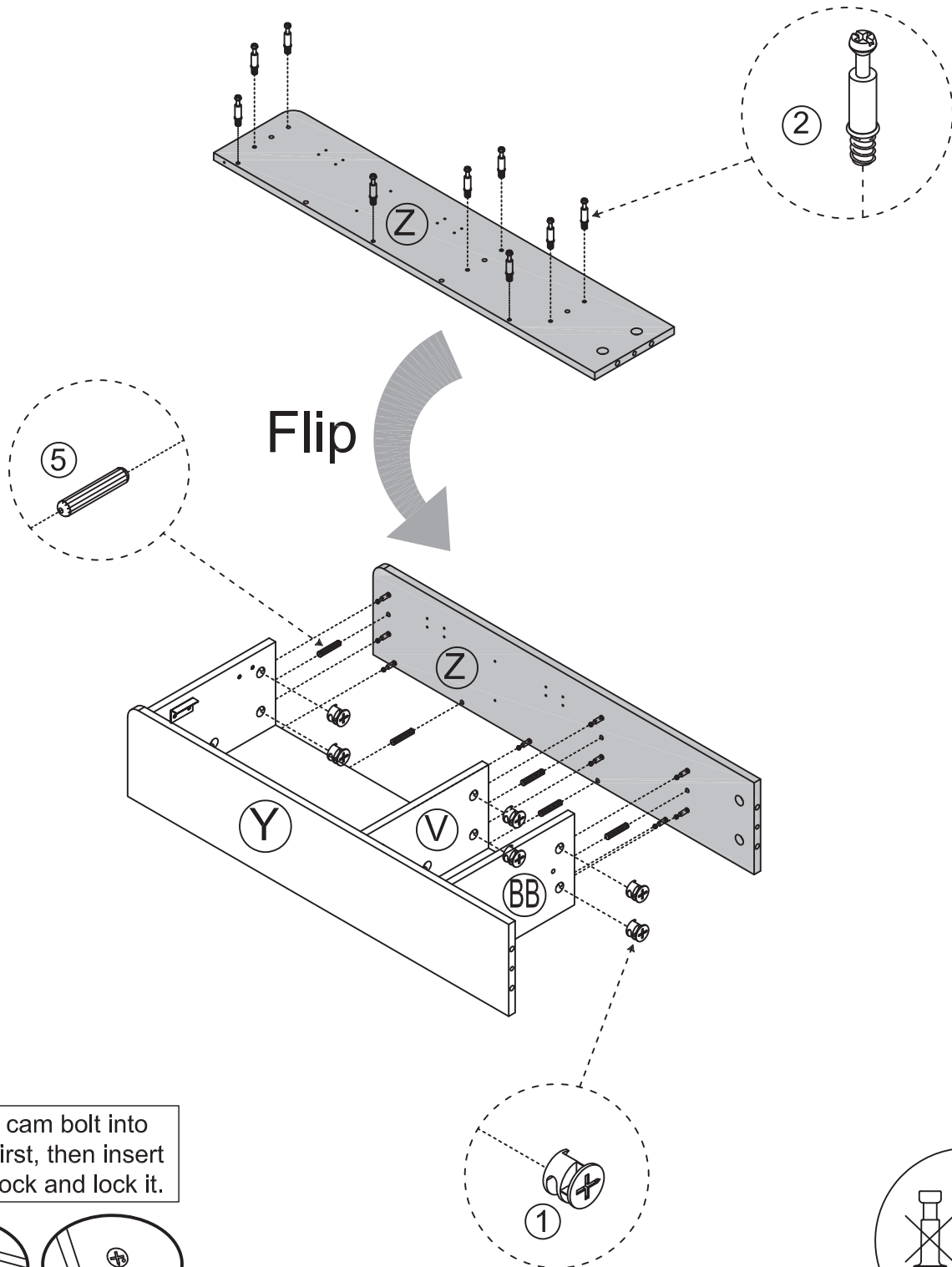
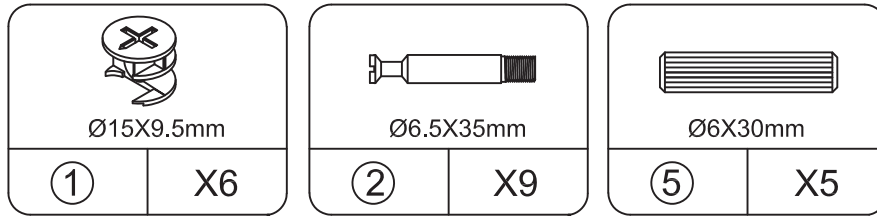

Insert the cam bolt into the hole first, then insert the cam lock and lock it.

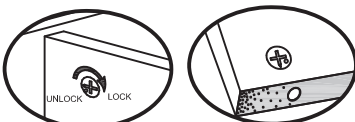

Proper orientation of CAM LOCK

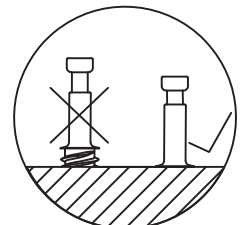
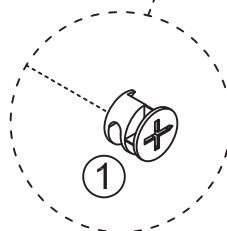

STEP24

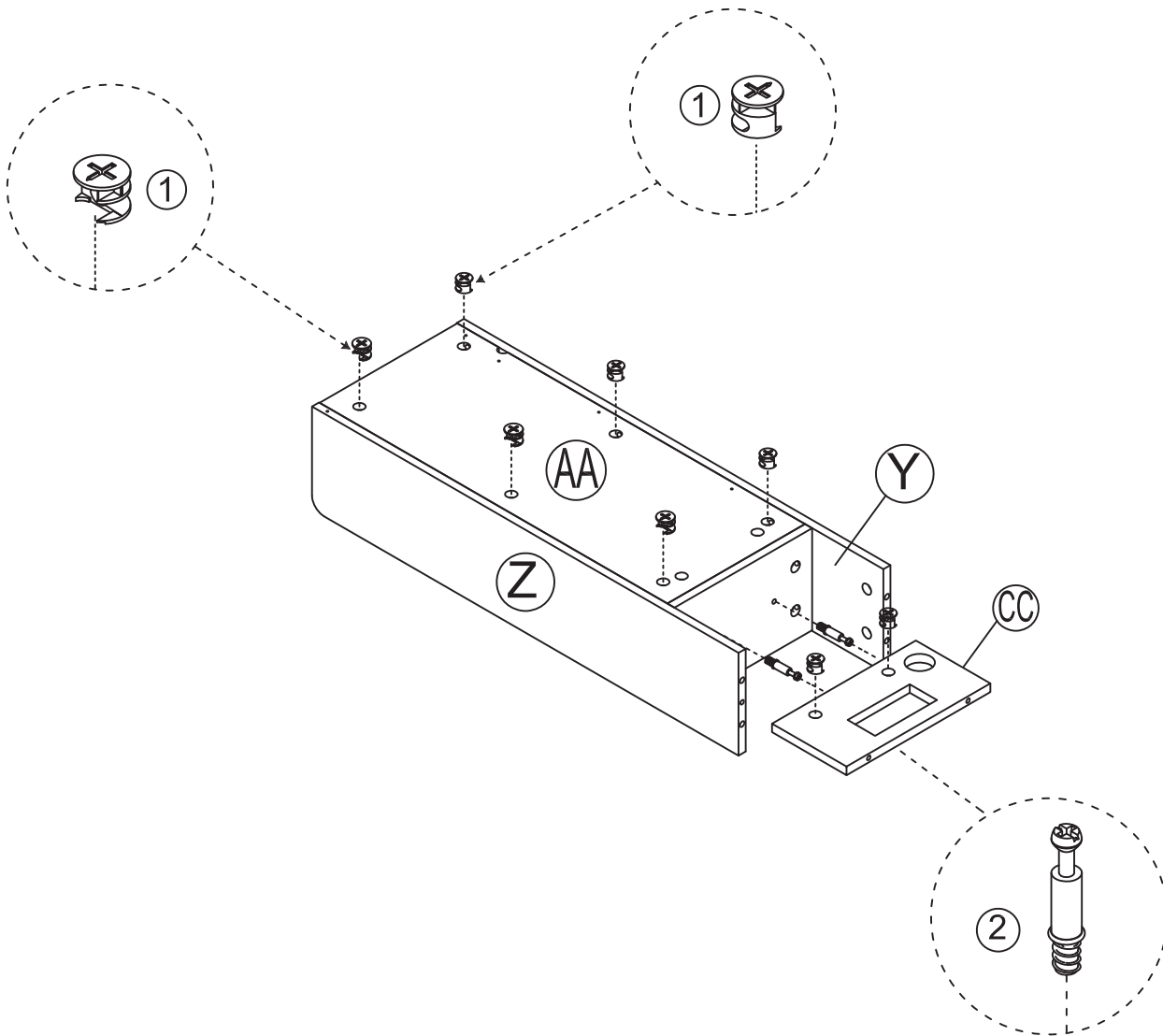
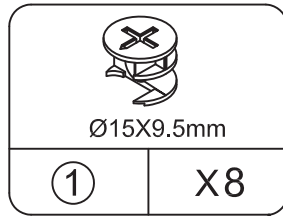
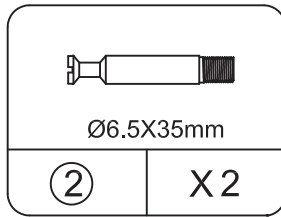

Insert the cam bolt into the hole first, then insert the cam lock and lock it.

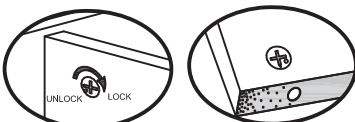

Proper orientation of CAM LOCK

STEP25

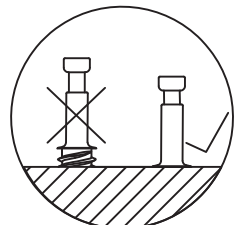
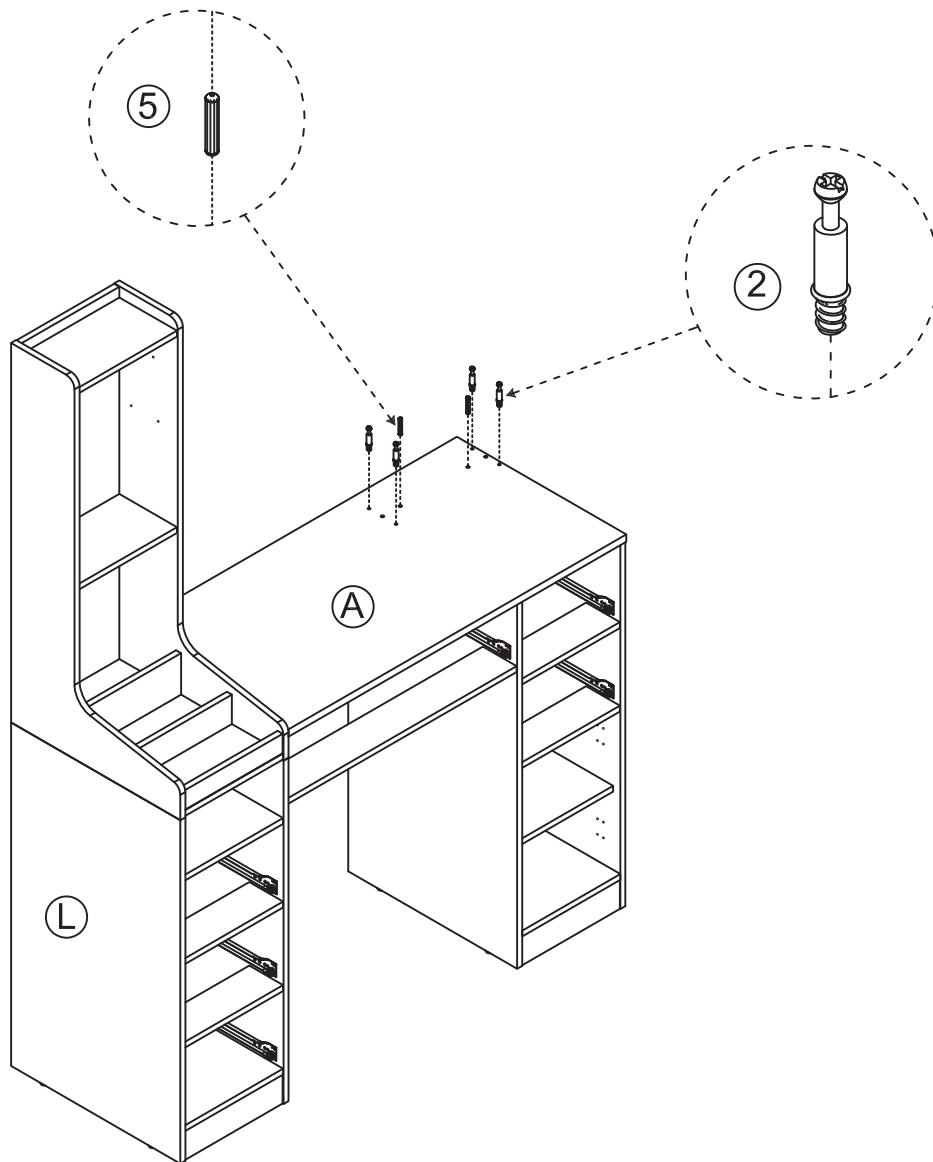
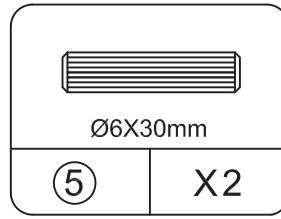
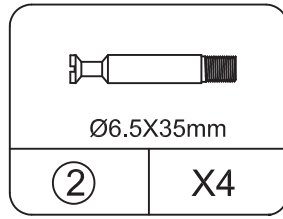

STEP26

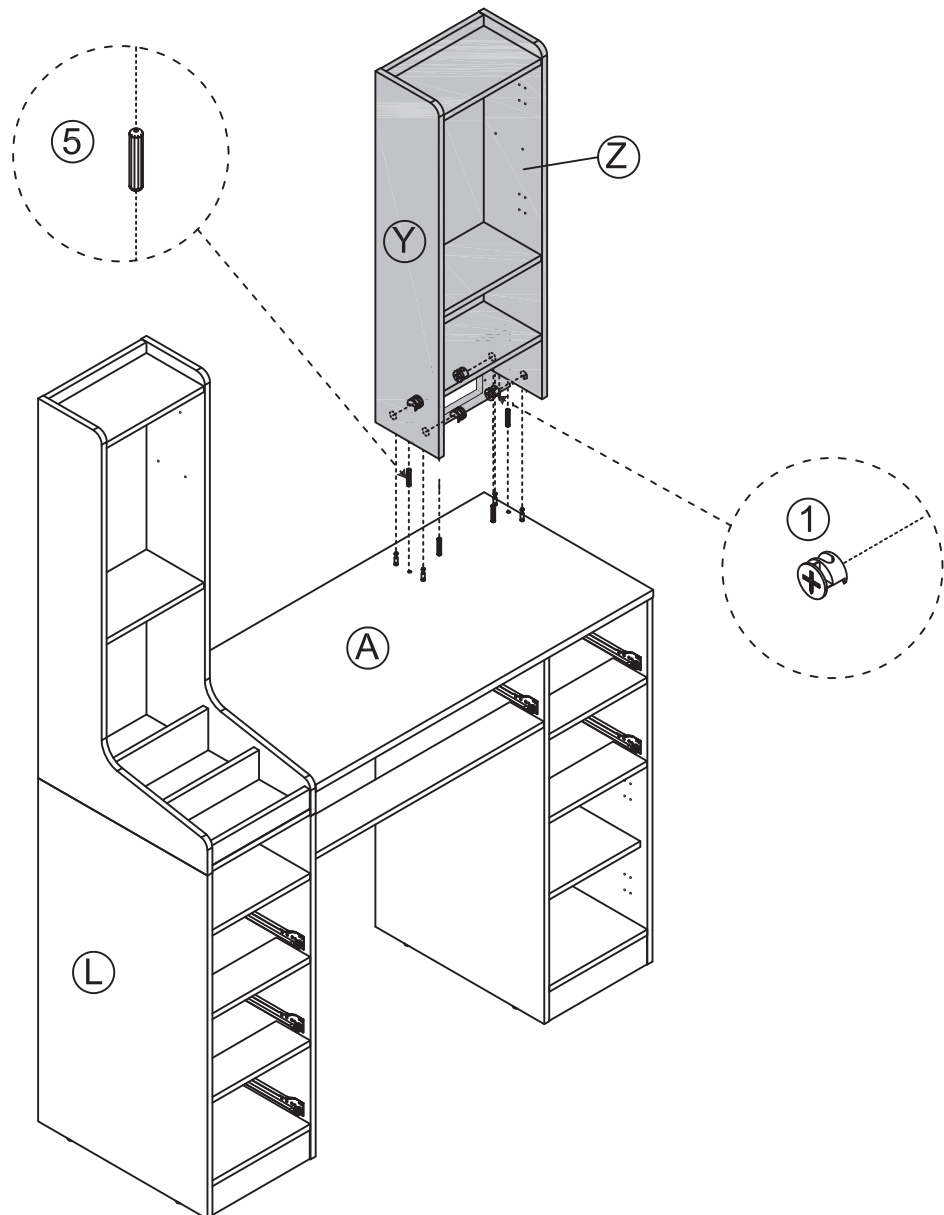
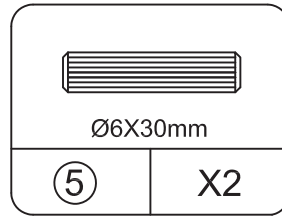
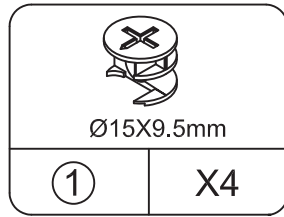

Insert the cam bolt into the hole first, then insert the cam lock and lock it.

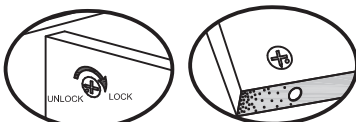

Proper orientation of CAM LOCK

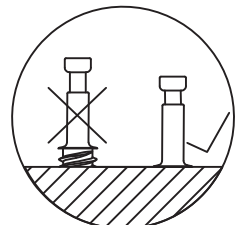

STEP27

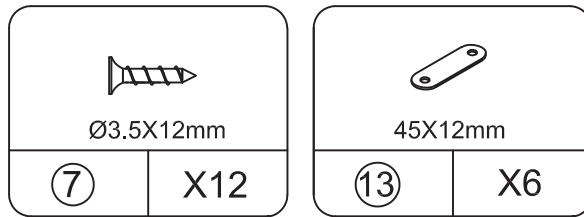

When installing accessories,
you need to move closer to the middle

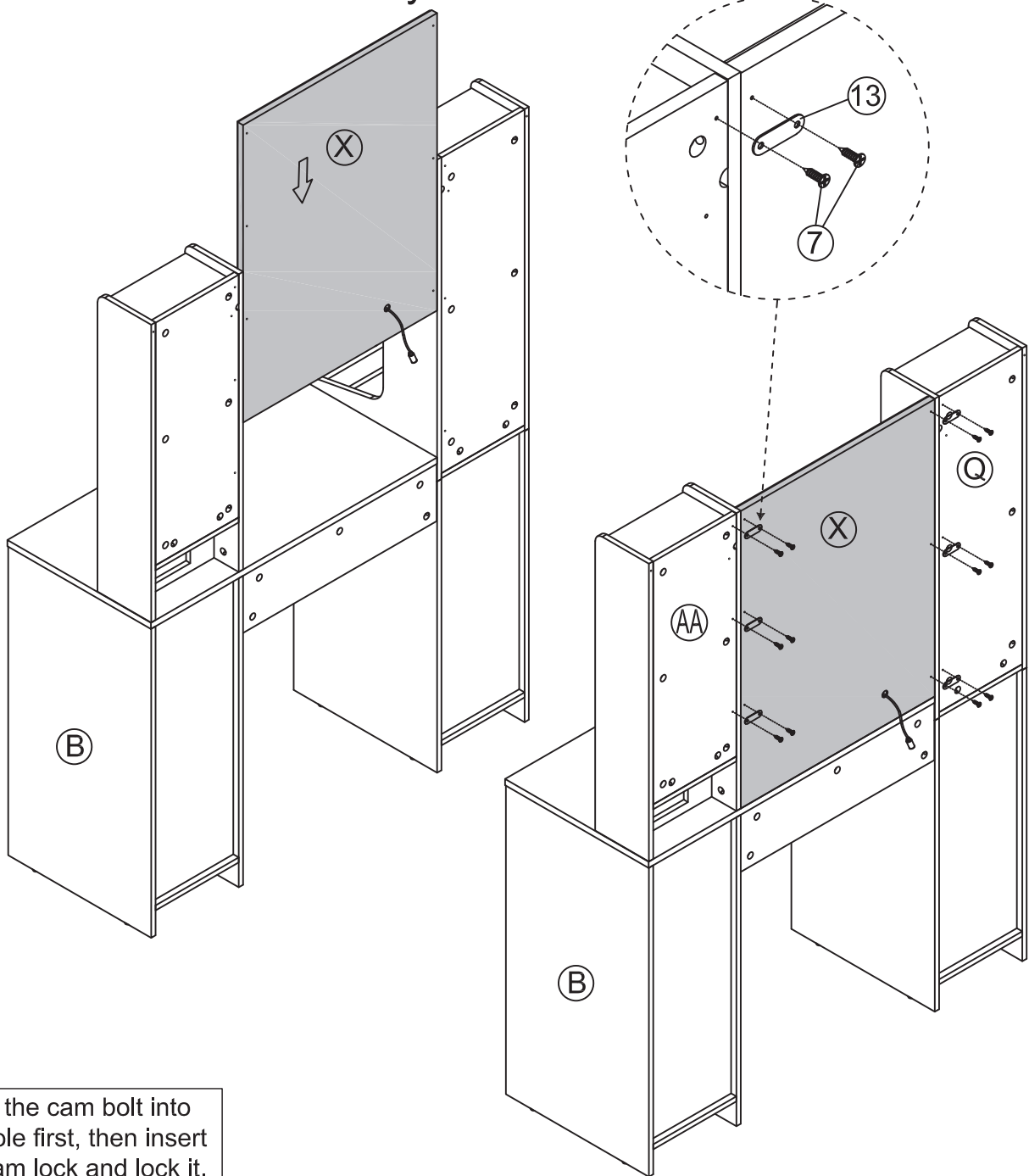

Insert the cam bolt into
the hole first, then insert
the cam lock and lock it.

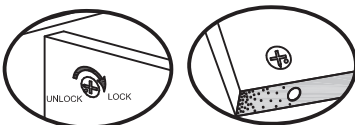

Proper orientation of CAM LOCK

STEP28

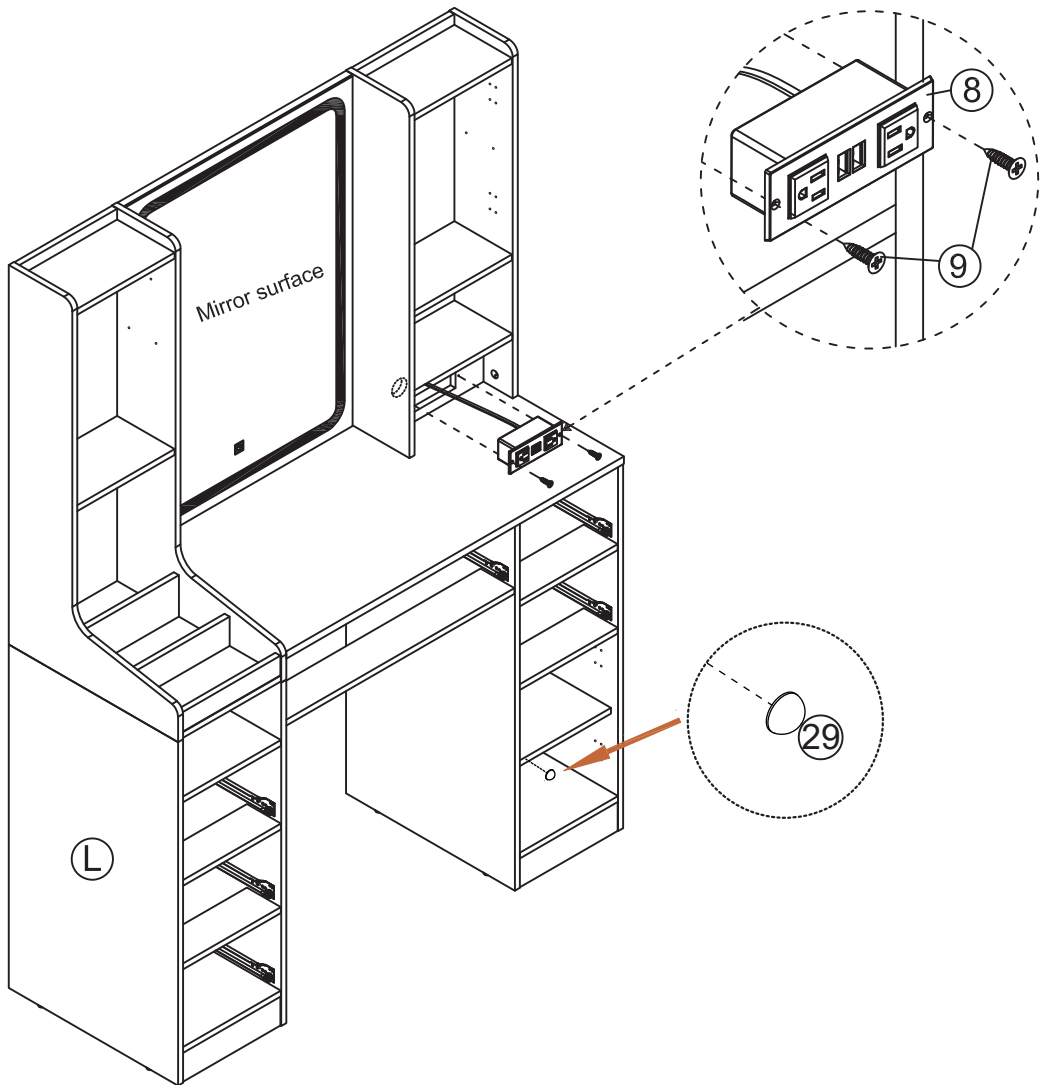
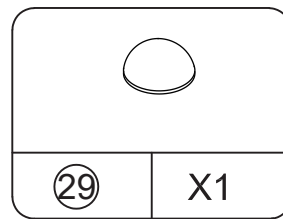
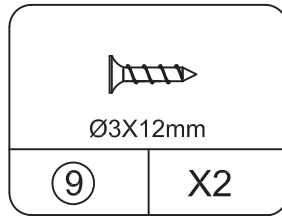
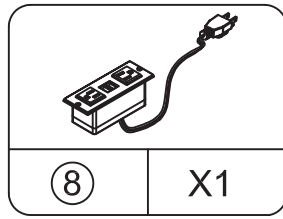

STEP29

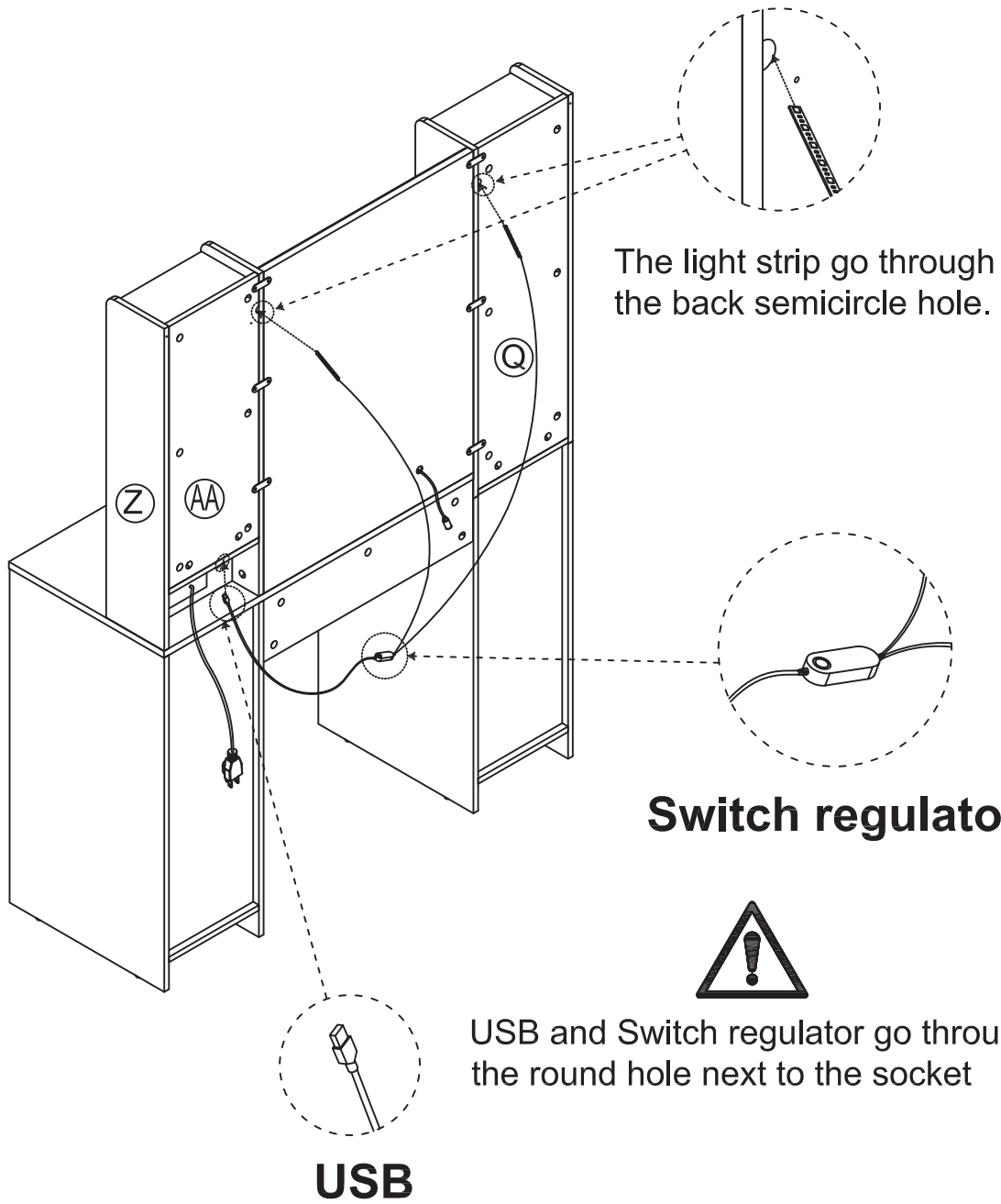
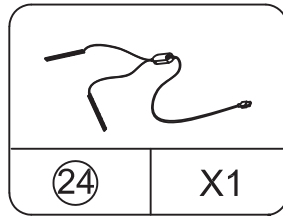

STEP30

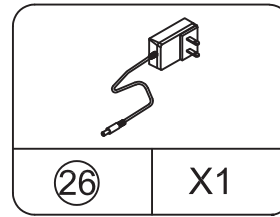
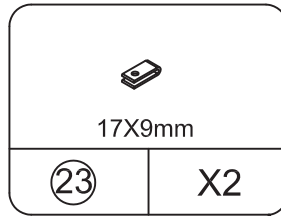
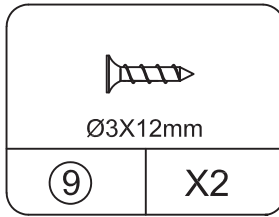

First of all, the lamp belt line is fixed on the P and Y board with the pressure buckle 23#, and then Tear off the back glue of the light strip and stick it on the PP and QQ board.



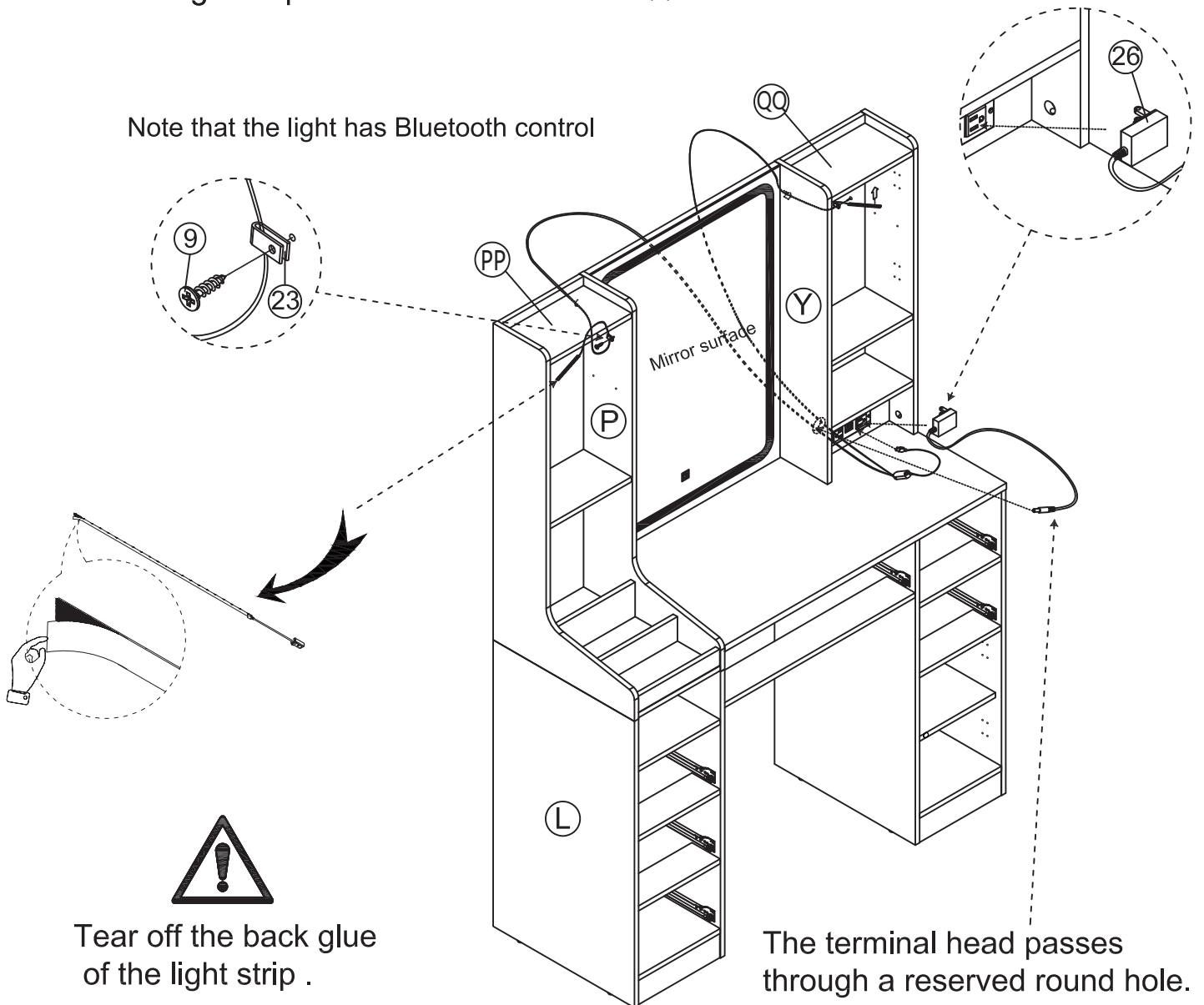

Note that the light has Bluetooth control



Tear off the back glue of the light strip .

The terminal head passes through a reserved round hole.

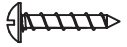
STEP31

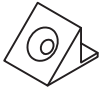
 Ø3X12mm	 17X9mm	 160X20mm	 Ø4X14 mm	  Ø3×14mm
⑨ X2	⑳ X2	㉑ X2	㉒ X2	㉓ X16set

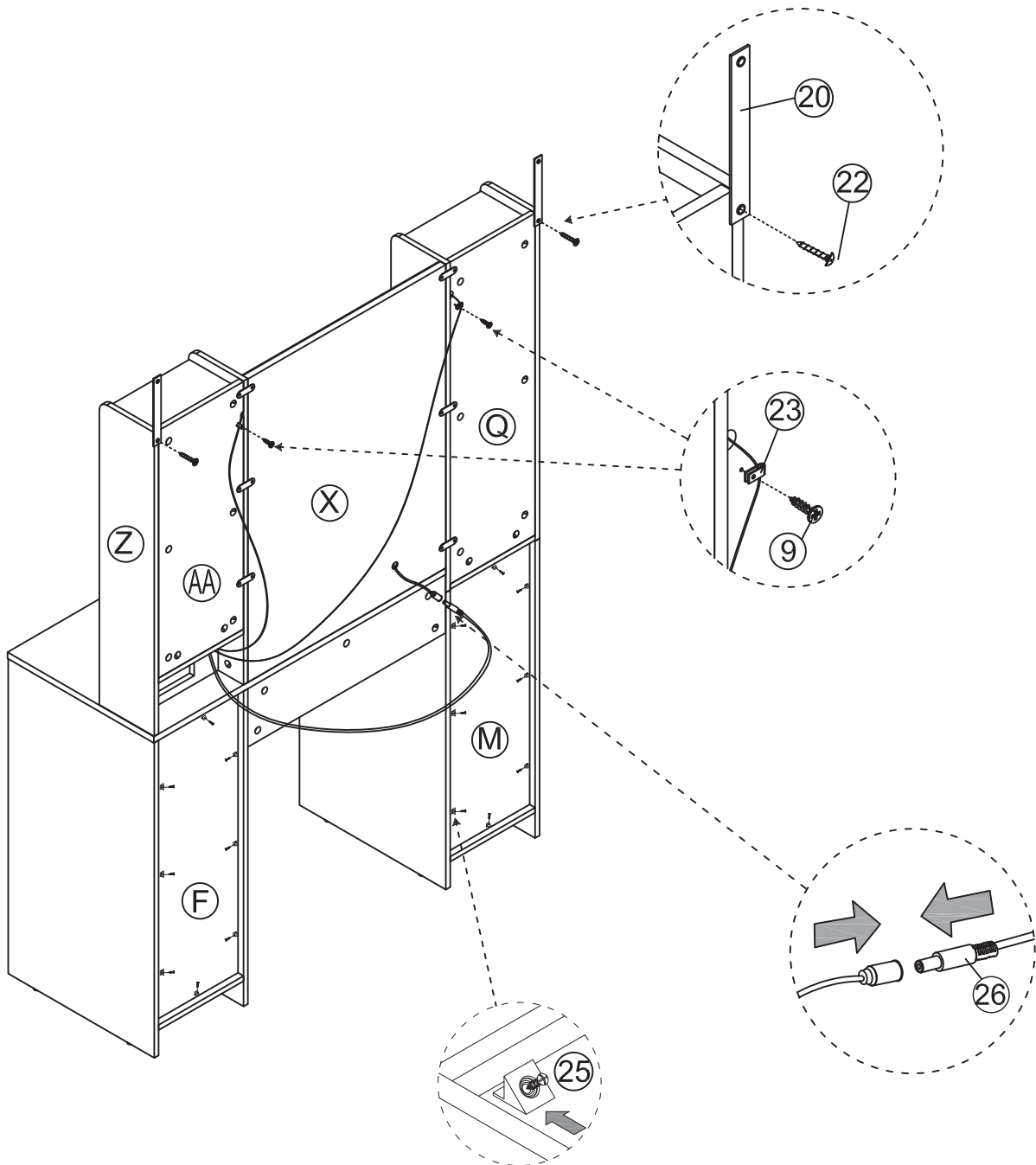

STEP32

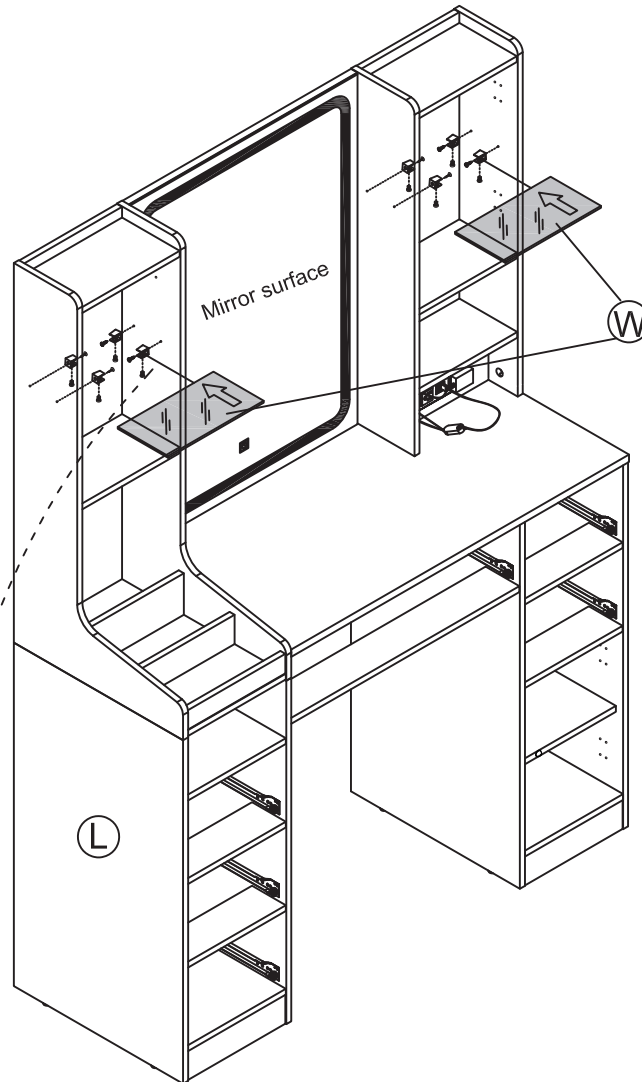
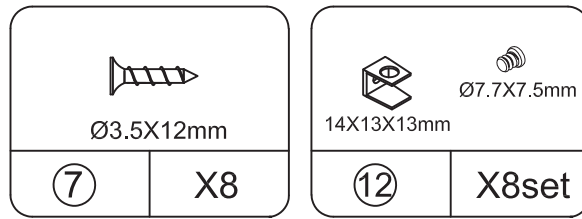

Step 1

Fix 12# with 7# Screw

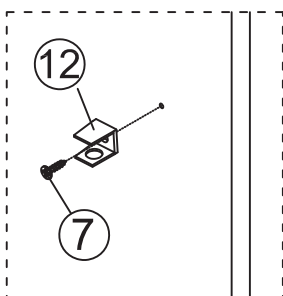

Step 2

Put the W part into 12# slot

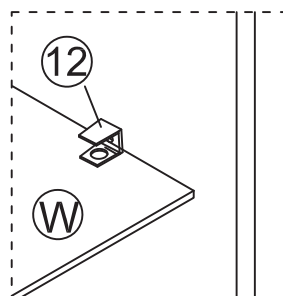

Step 3

Rotate 12# to secure the W part

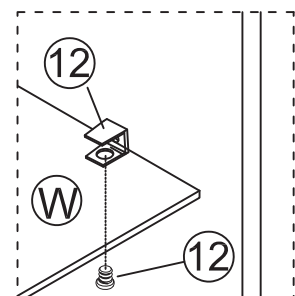

STEP33

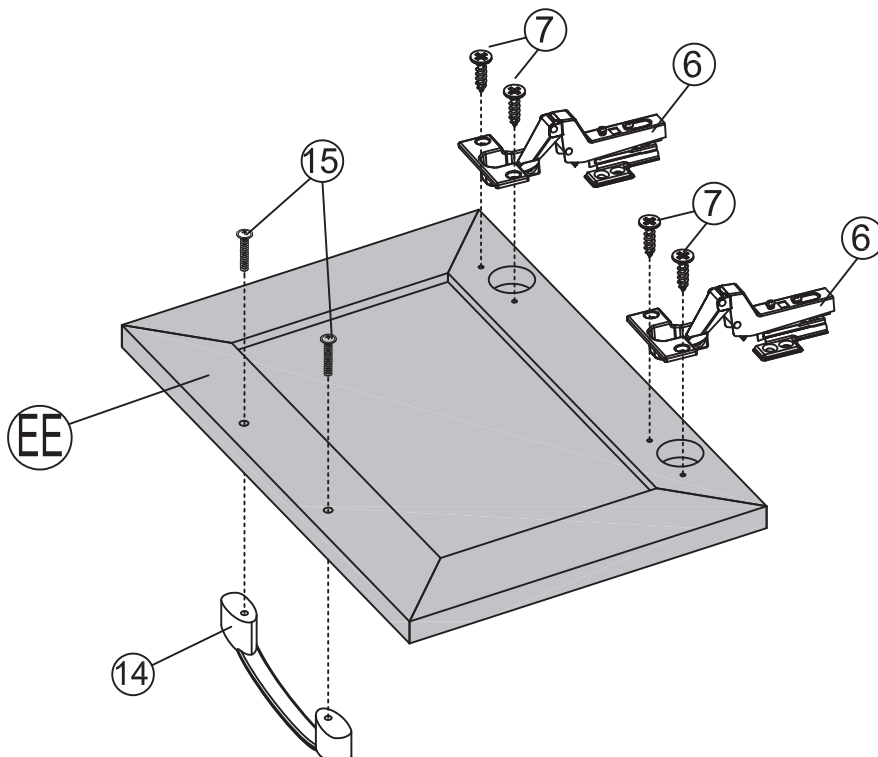
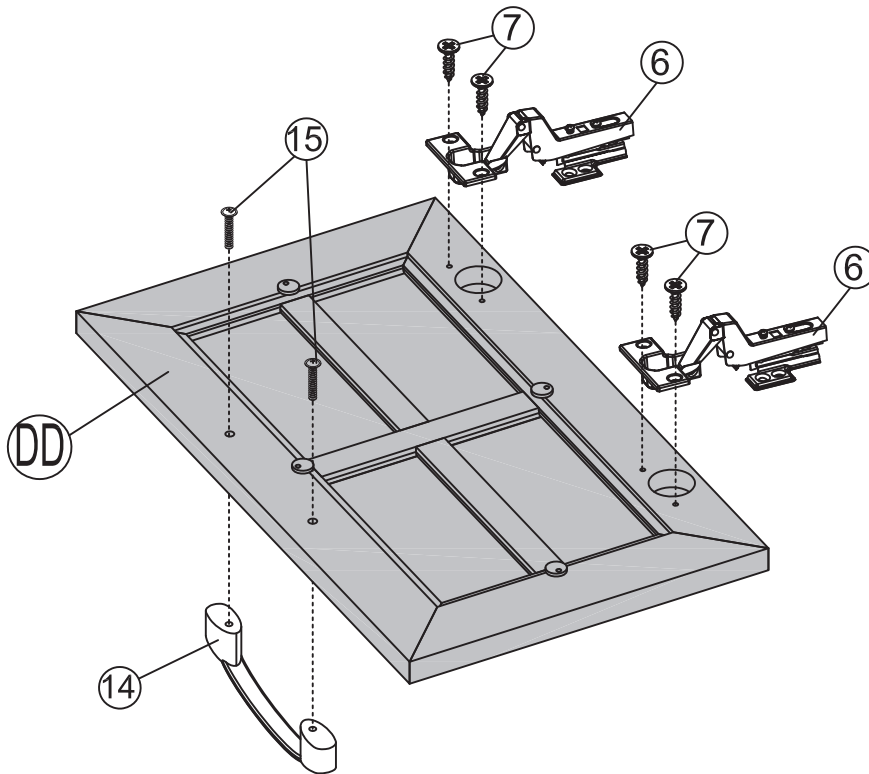
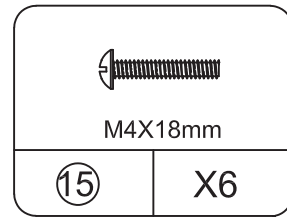
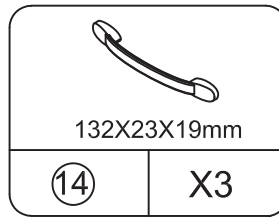
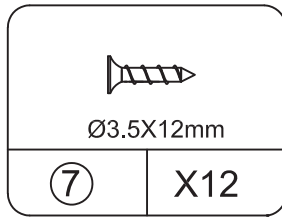
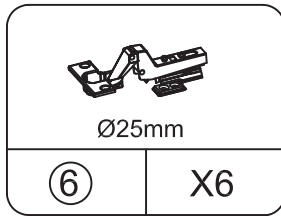

STEP34

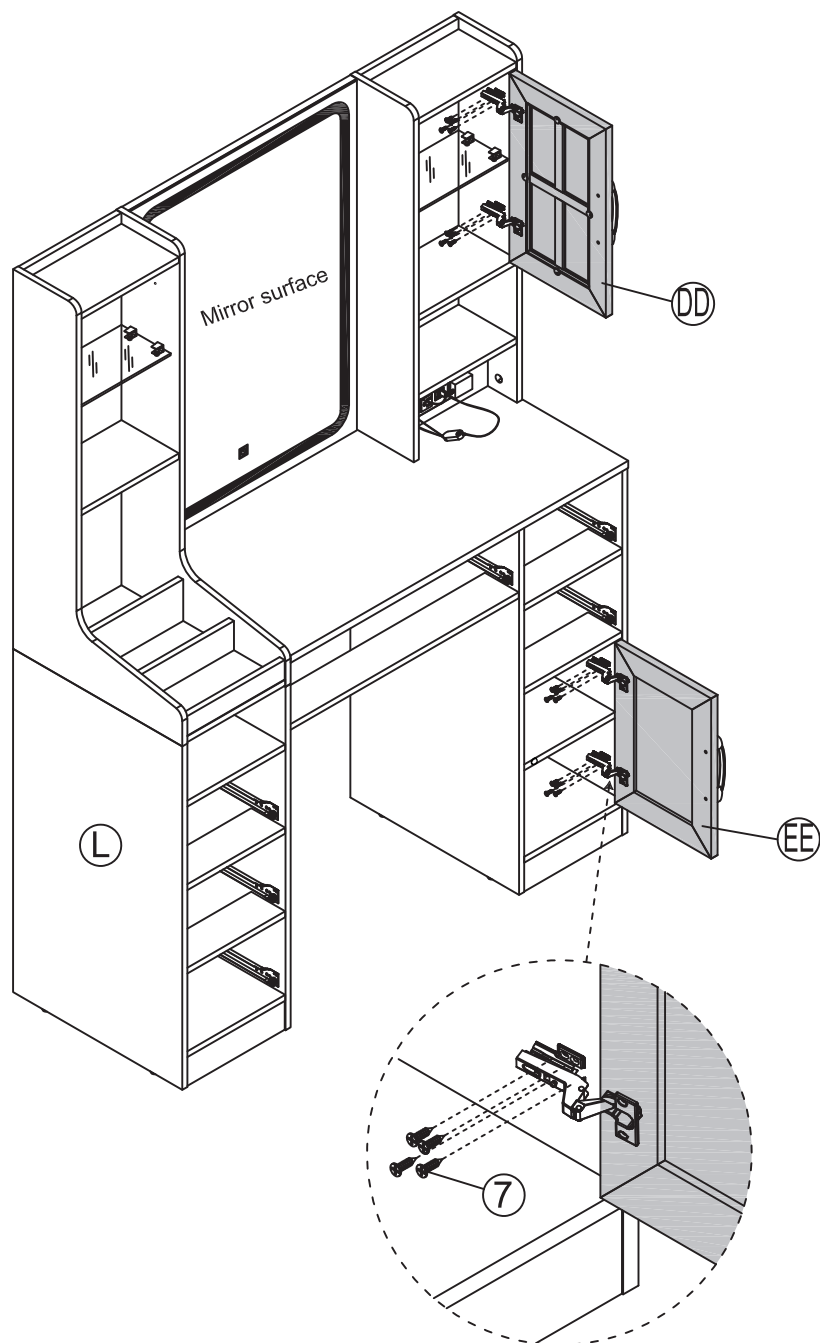
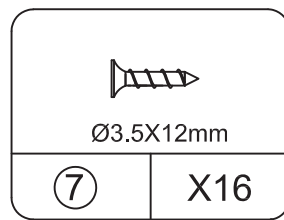

STEP35

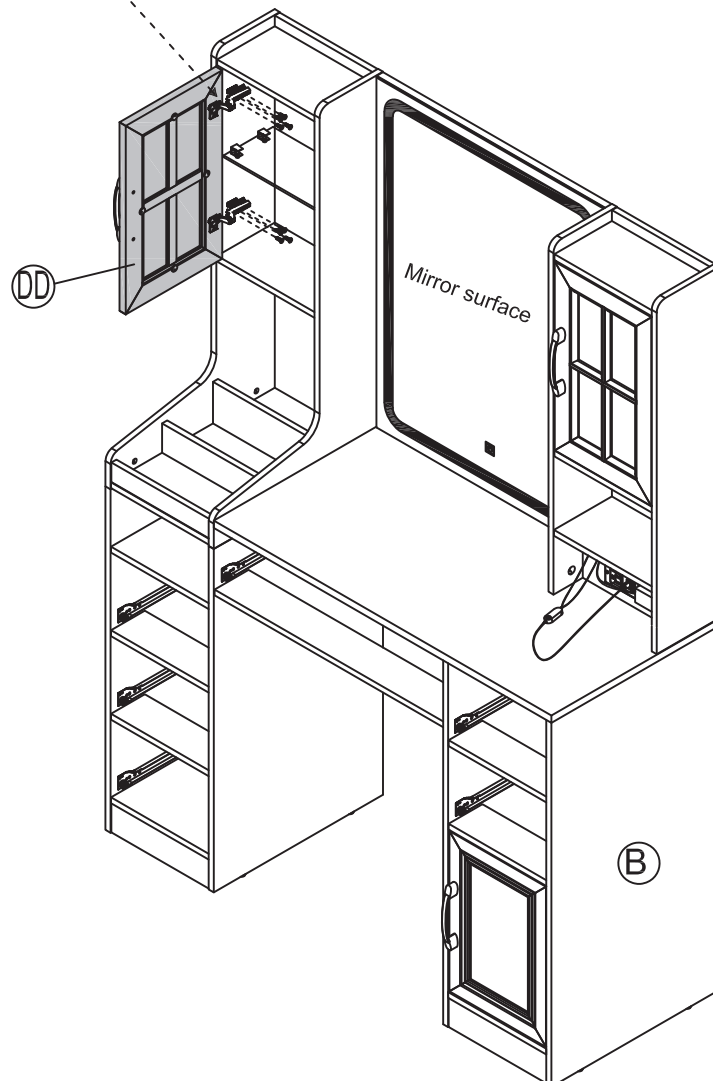
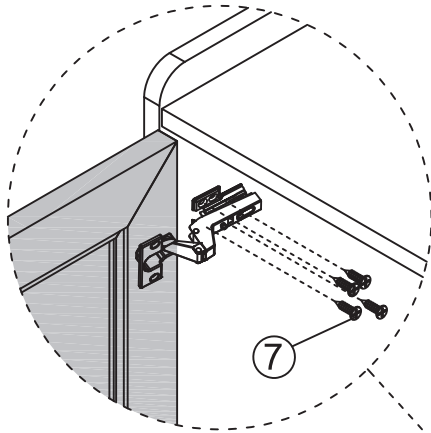
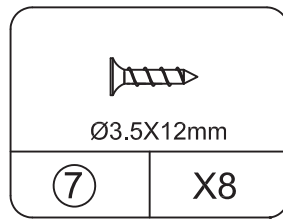

STEP36

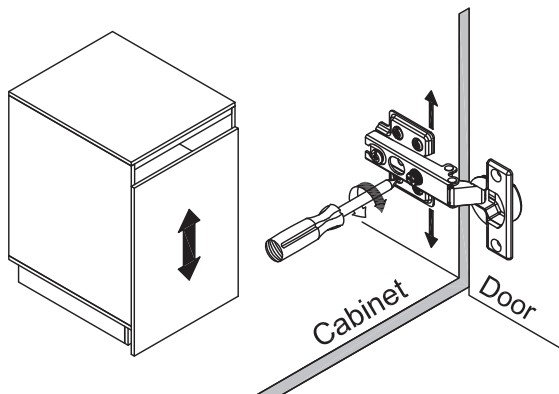
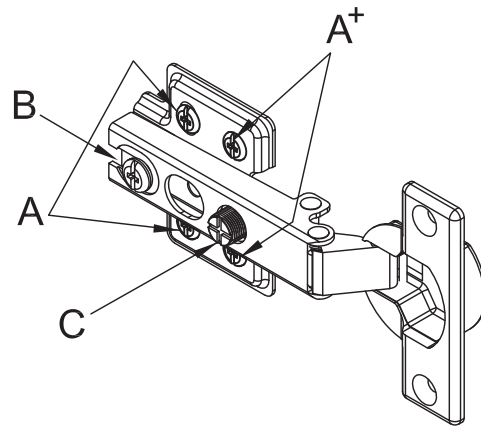

[How to adjust vertical height of the door]

- First remove the 2 screws "A+" on the hing .
- Then loosen the 2 screws "A" on the hinge so that it can be adjusted up or down a few millimeters.
- Then tighten "A" and reinstall "A+".

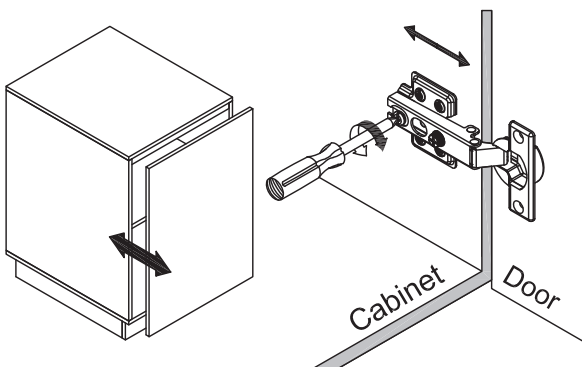

[How to adjust depth of the door]

- Loosen screw "B" and adjust the depth of th door.
- If screw "B" is loose, the depth of the door stil cannot be adjusted. Simply loosen the screw "C" slightly to adjust the position of the door forward and backward.
- After adjusting the position, tighten screw "B" last.

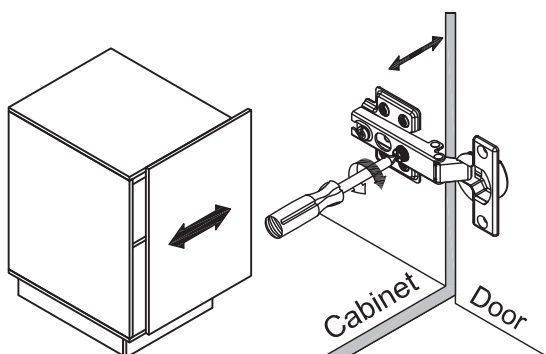

[How to adjust the level of the door]

- Turn screw "C" on hinge to adjust the level of

STEP37



Ø15X9.5mm

①	X20
---	-----

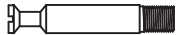

Ø6.5X35mm

②	X20
---	-----

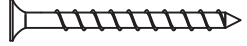

Ø4X35mm

⑩	X20
---	-----



Ø29X24mm

⑯	X5
---	----



M4X8mm

⑰	X5
---	----

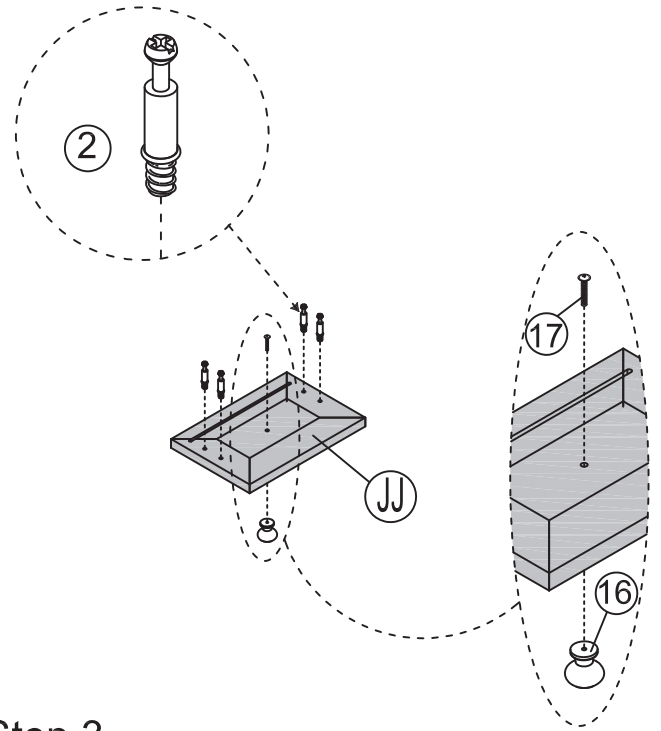
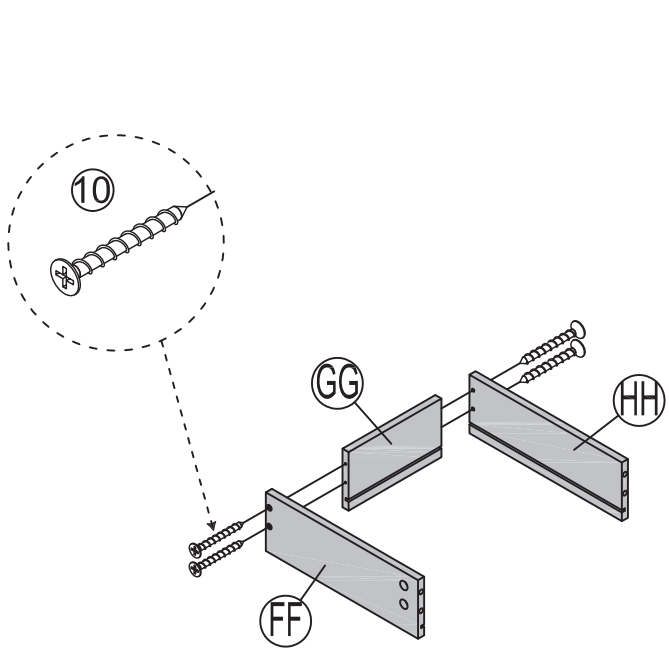

Step 1 Step 3
Step 2 Step 4

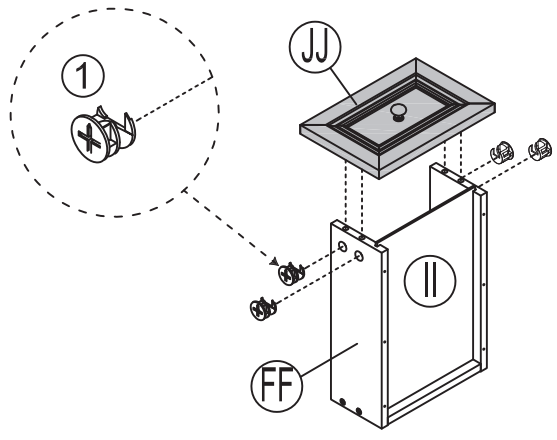
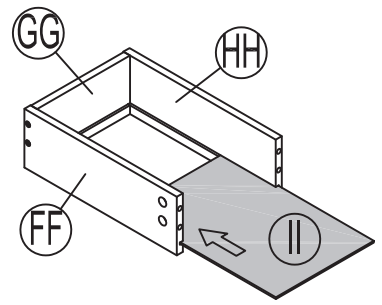

Insert the cam bolt into the hole first, then insert the cam lock and lock it.

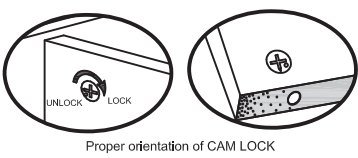

X5

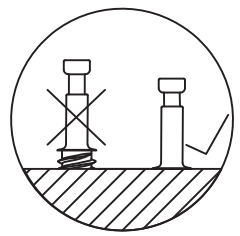

STEP38

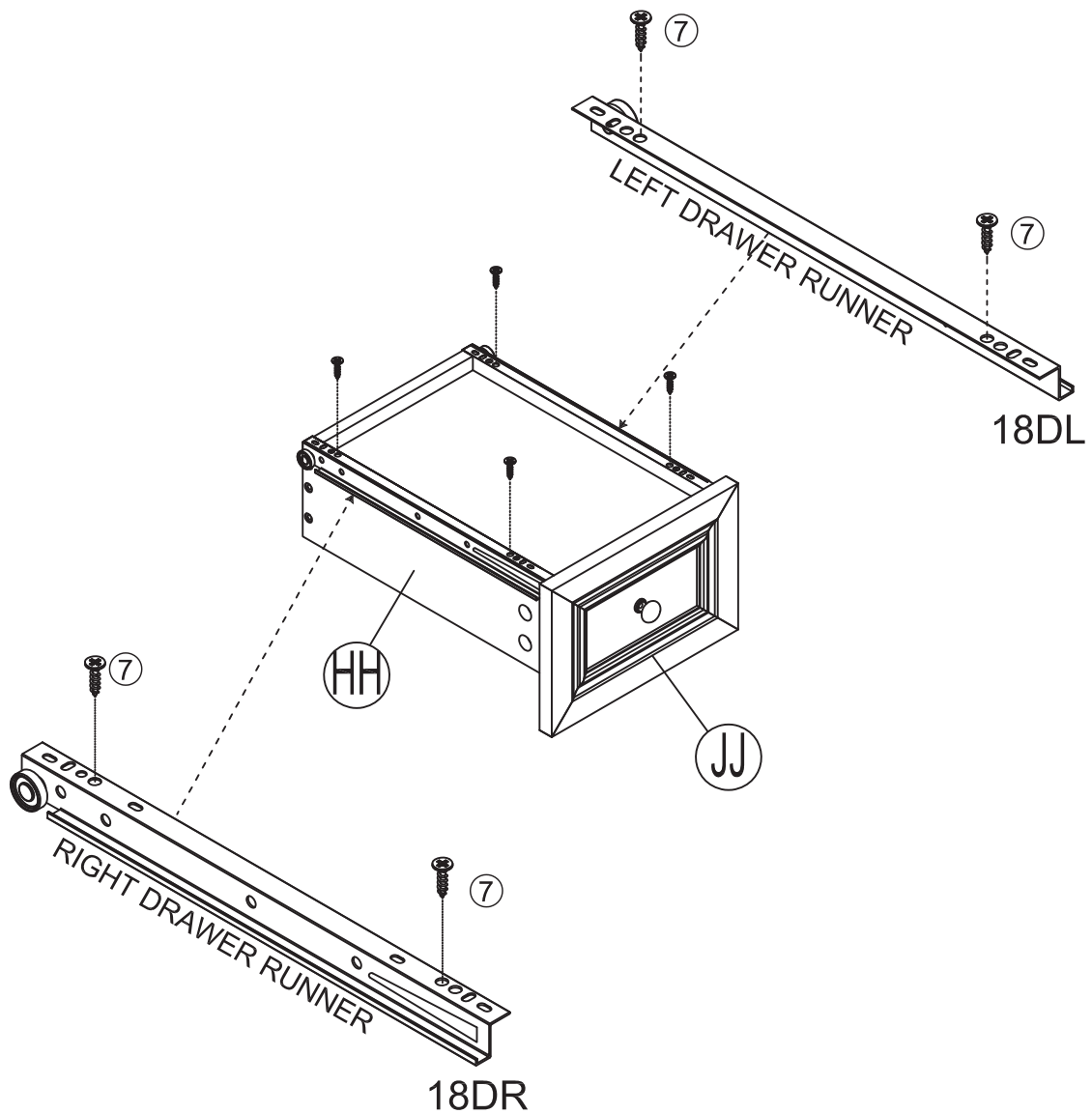
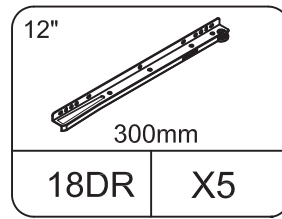
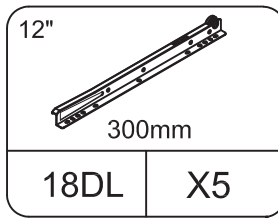
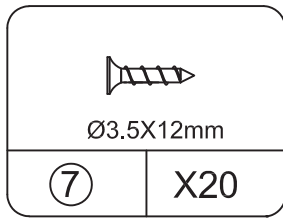

X5

STEP39



Ø15X9.5mm

①	X4
---	----

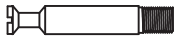

Ø6.5X35mm

②	X4
---	----

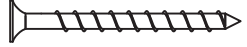

Ø4X35mm

⑩	X4
---	----



132X23X19mm

⑭	X1
---	----



M4X8mm

⑰	X2
---	----

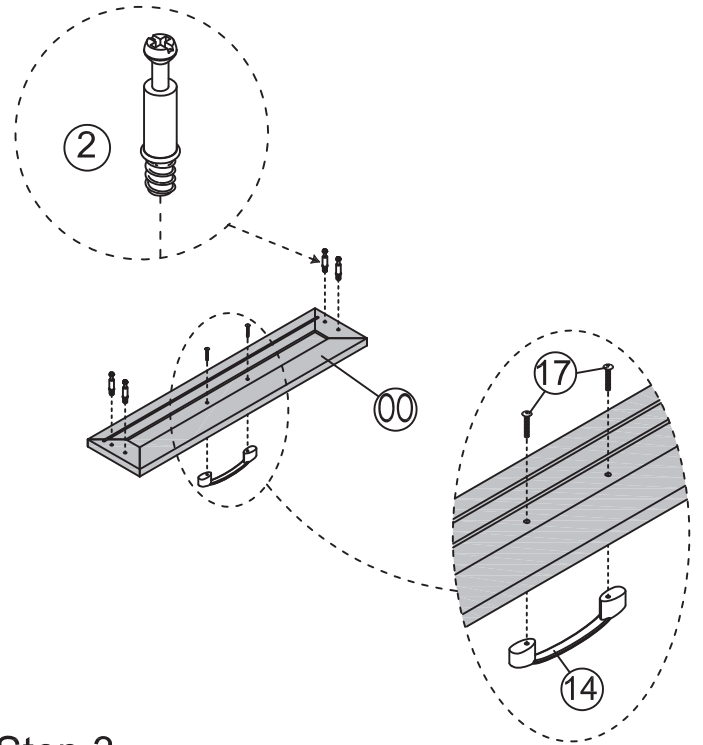
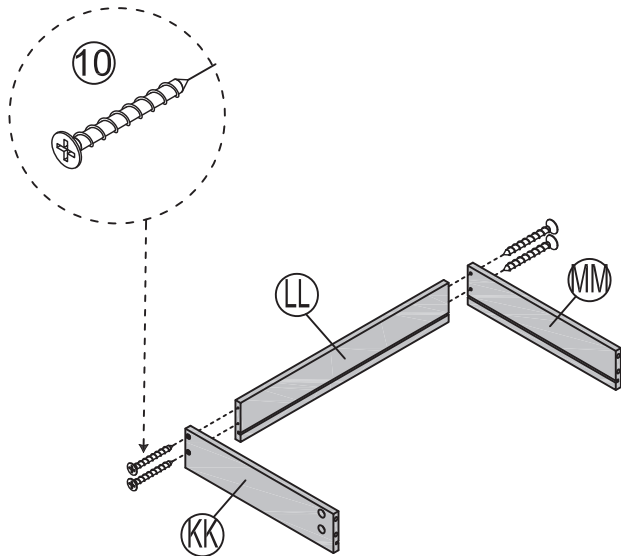

Step 1 Step 3

Step 2 Step 4

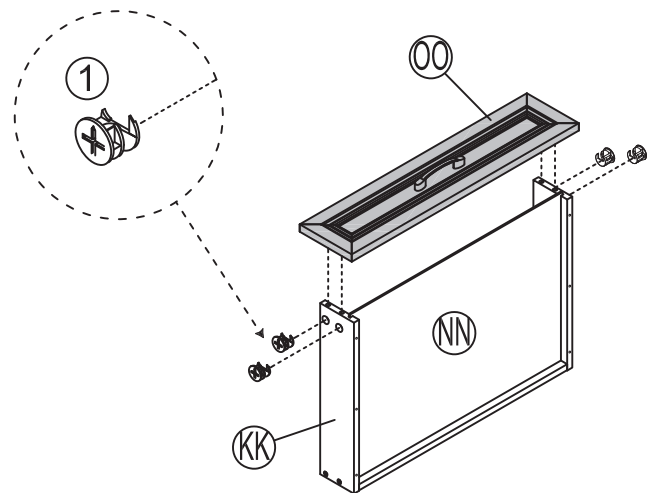
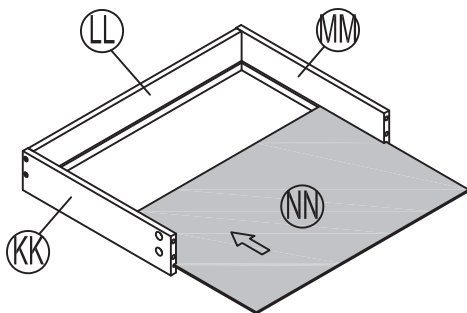

Insert the cam bolt into the hole first, then insert the cam lock and lock it.



Proper orientation of CAM LOCK

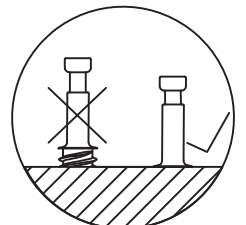

STEP40

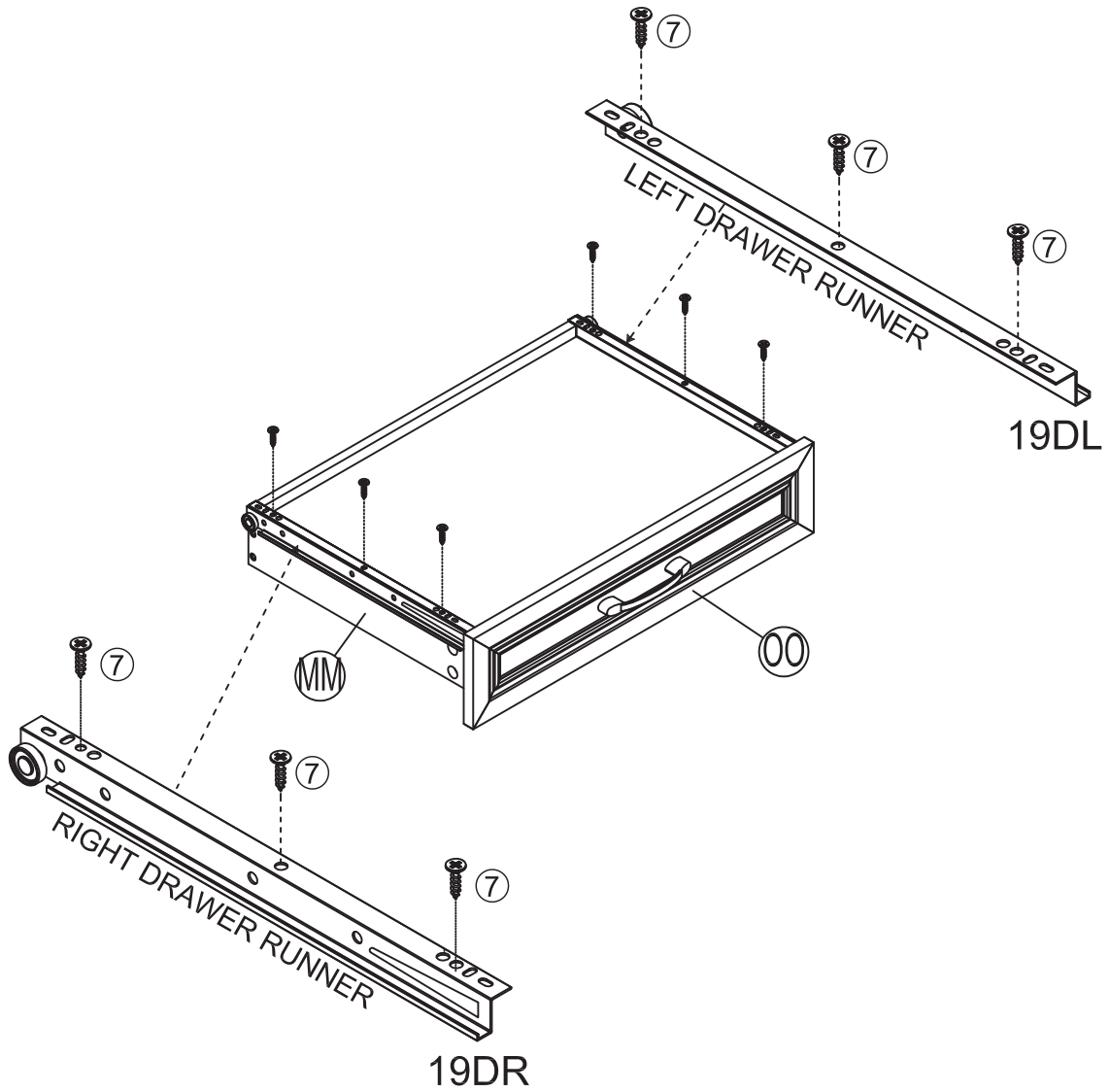
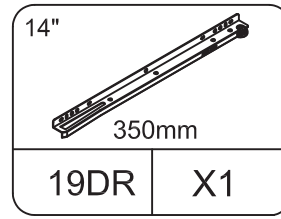
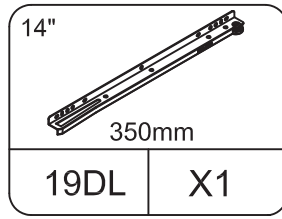
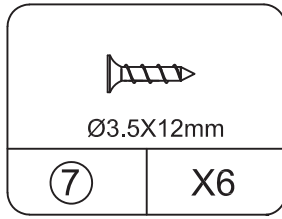

STEP41

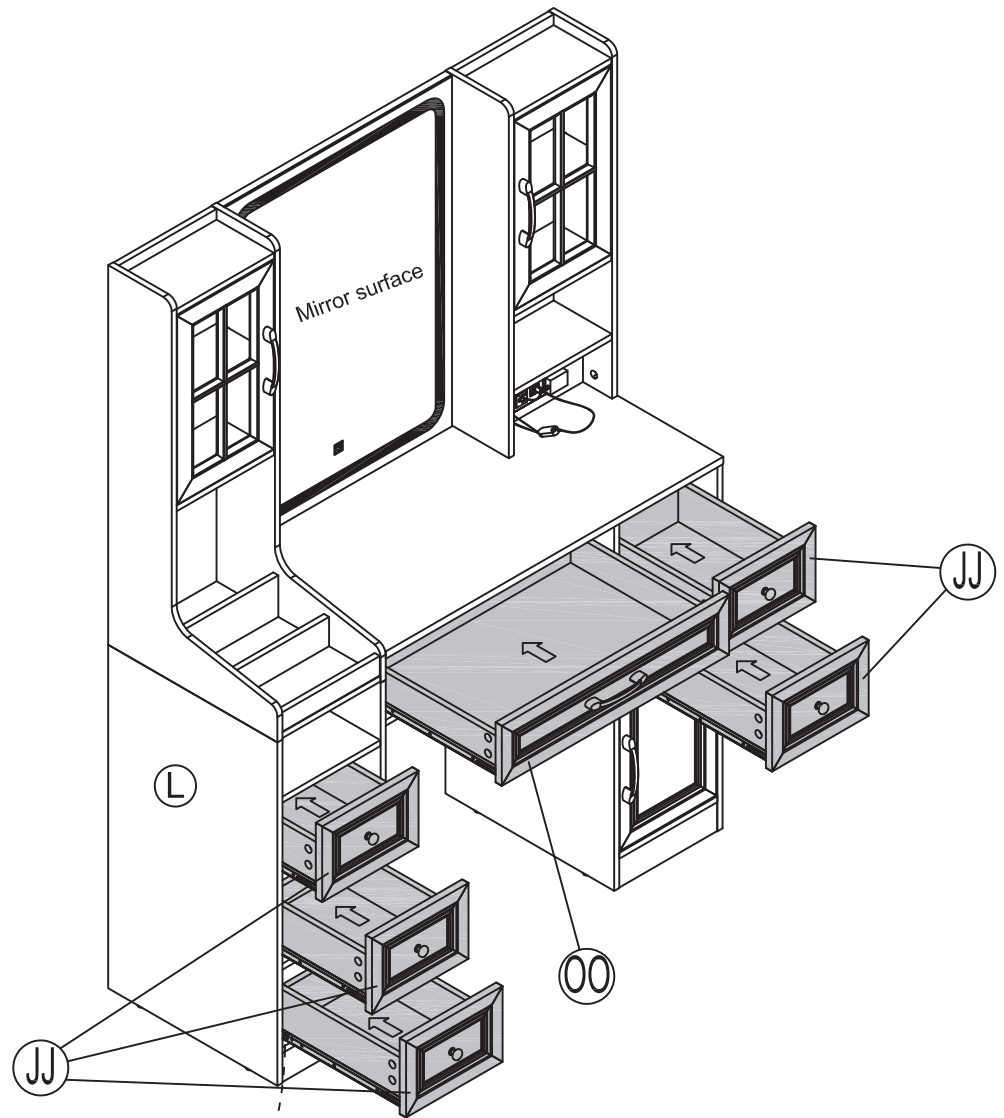

Cabinet Slide

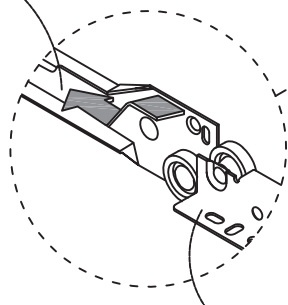

Drawer Slide

STEP42

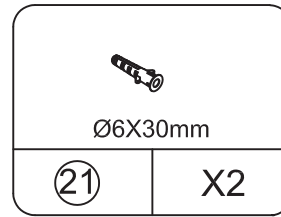
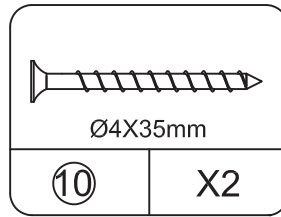

Install the tipping restraint hardware

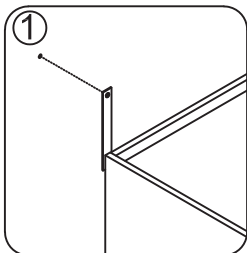

1. make mark on the wall

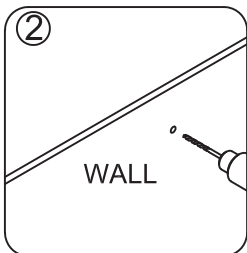

2. drill one Ø6 holes on the wall

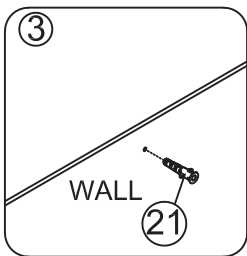

3. put one anchors in the holes

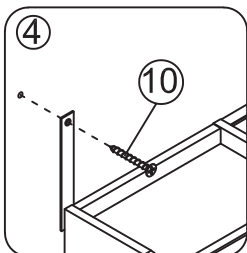

4. fix the device on the wall by the long screws

