

LTS416-S

Dresser

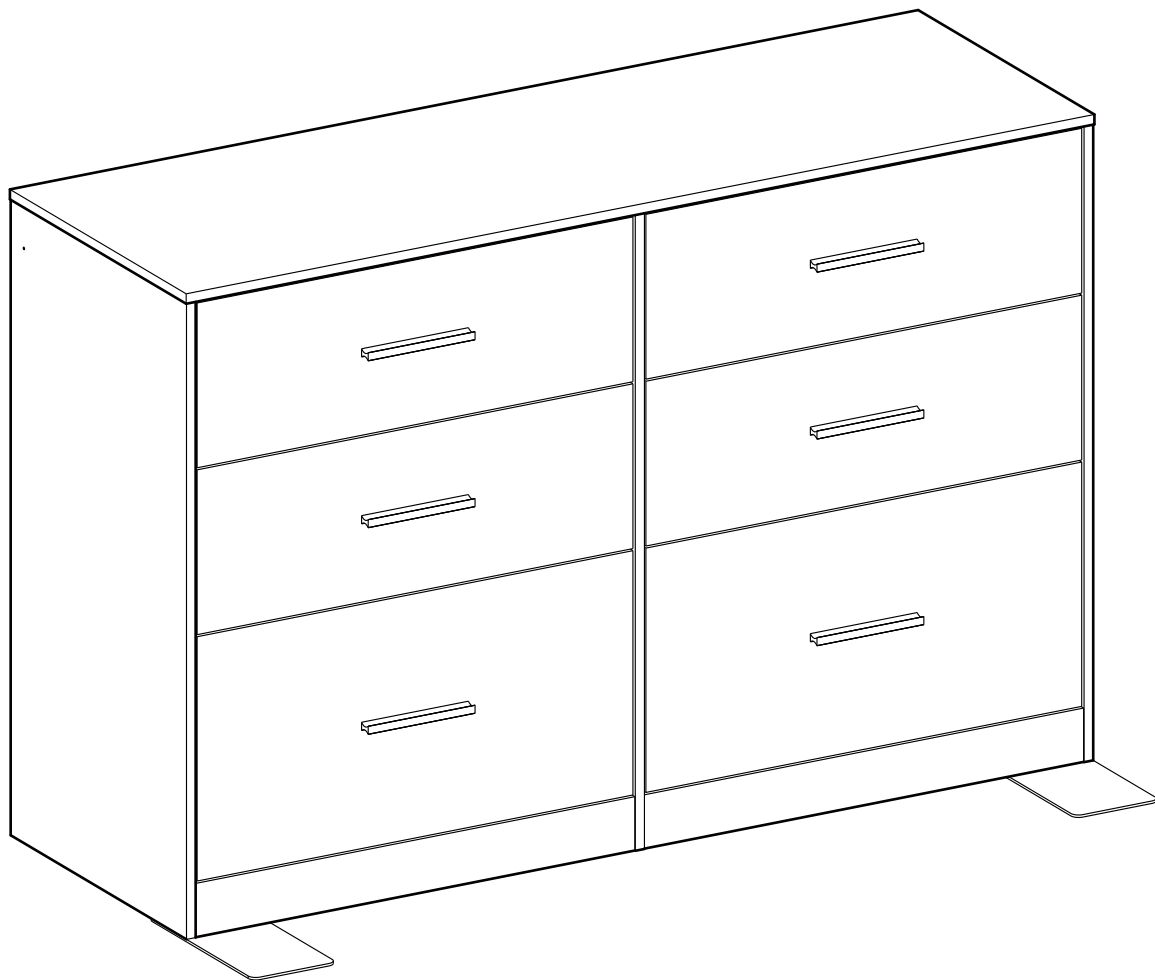

VASAGLE
by SONGMICS HOME

A × 1

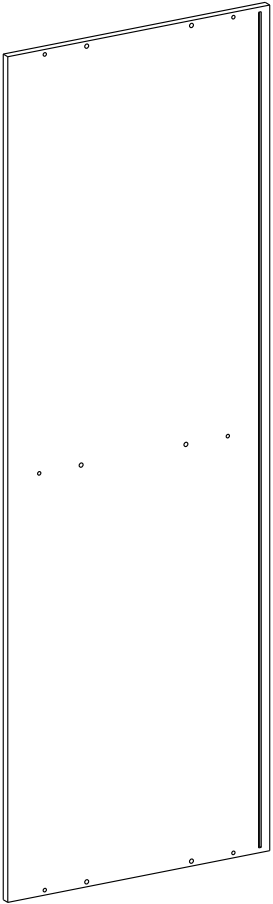

B × 2

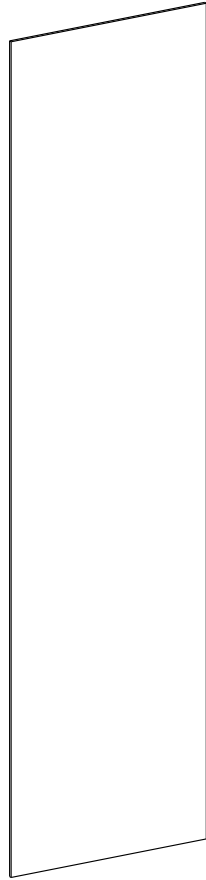

C × 1



E × 1



G × 1

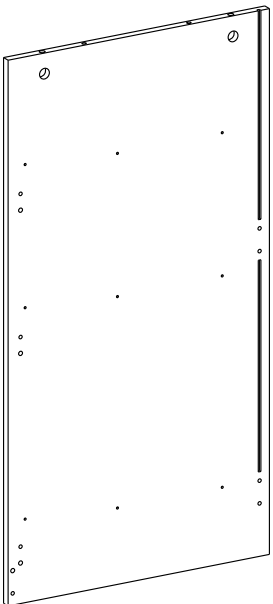

H × 1

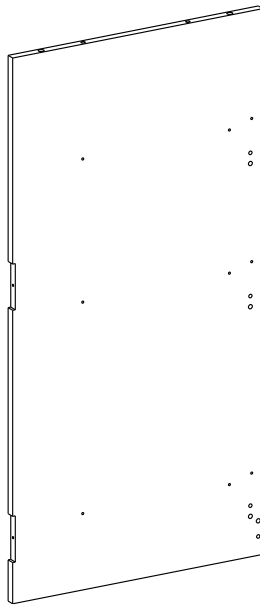

I × 1

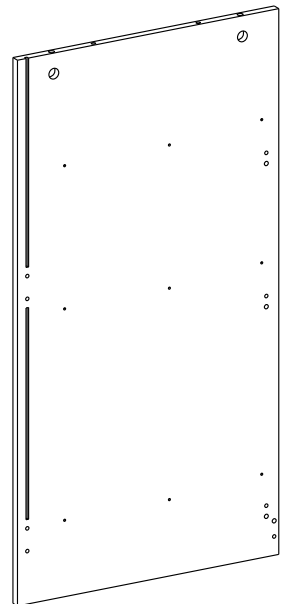

J × 6

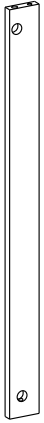

K × 2



L × 2

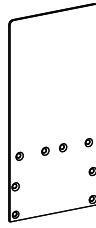

N × 4

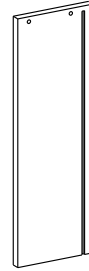

O × 4

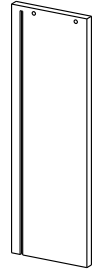

P × 4

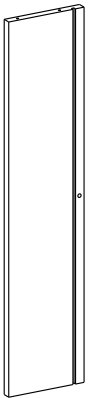

Q × 6

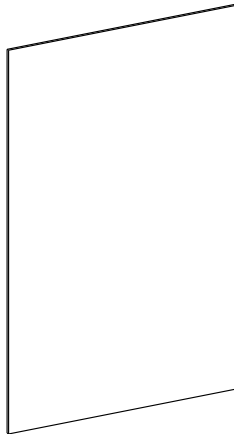

R × 6



S × 2

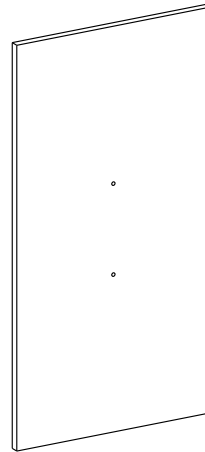

T × 4

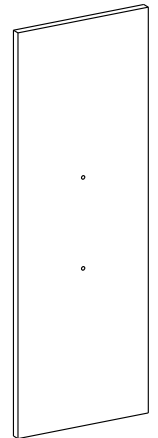

U × 2

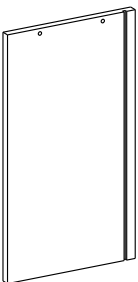

V × 2

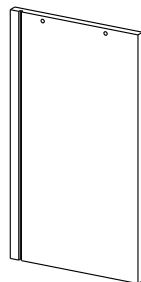

W × 2

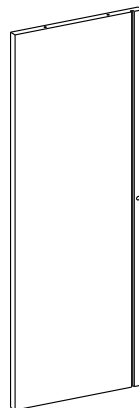

1 60+2

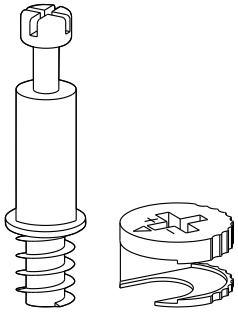

2 14+2

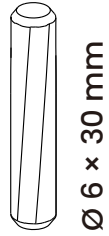

3 4+1

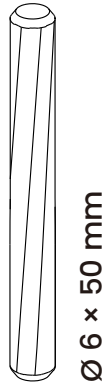

4 32+2



5 x 6

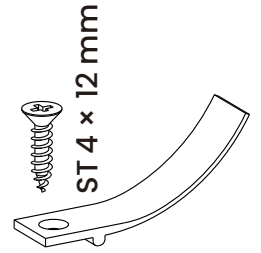

6 60+2



7 x 8

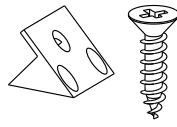

8 x 6



9 x 2

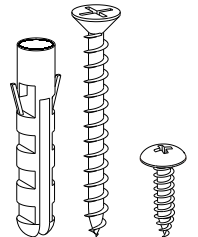
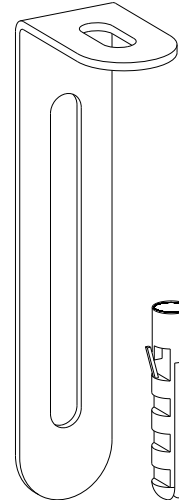

10 x 6

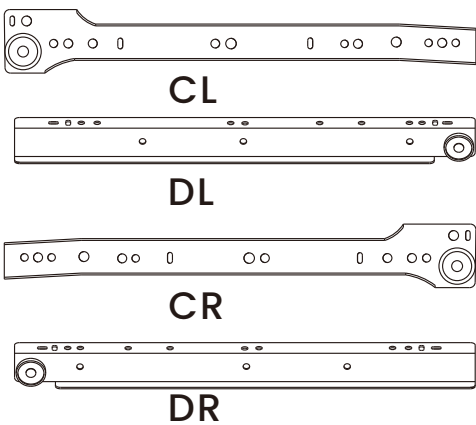

11 8+2



12 24+2



13 x 1

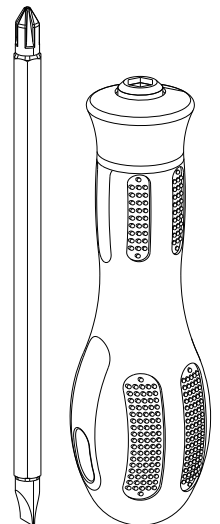

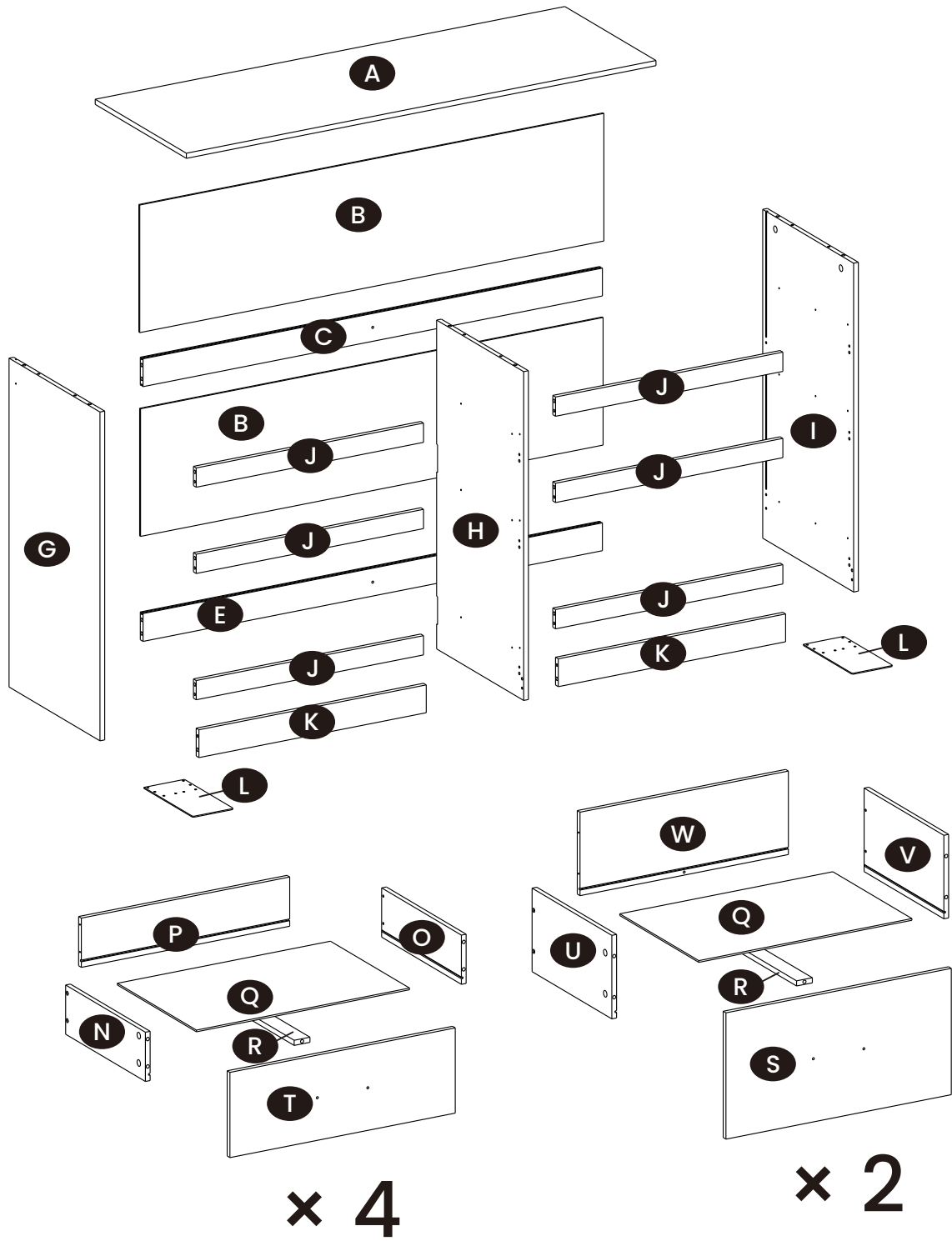

Tools Required:

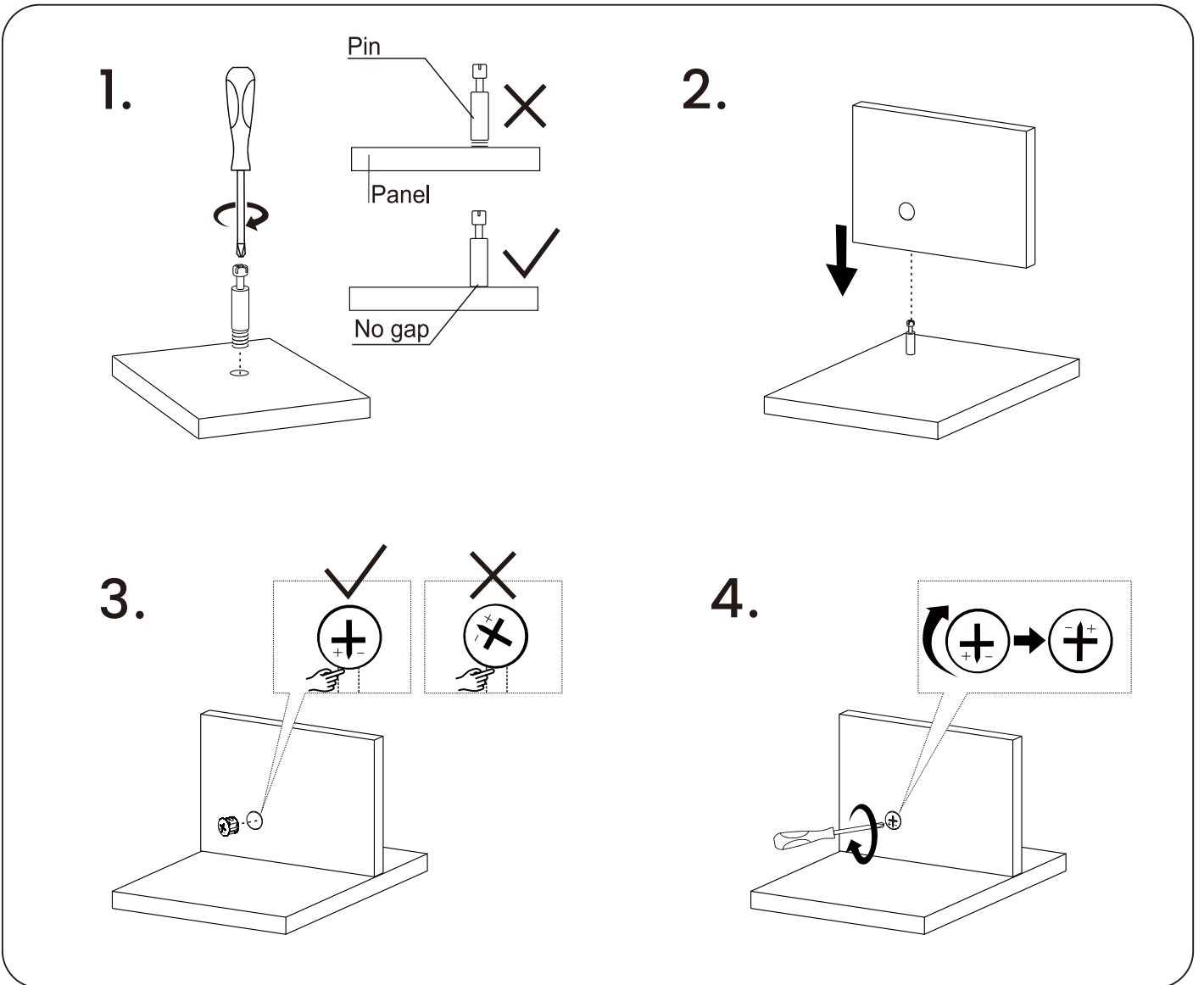
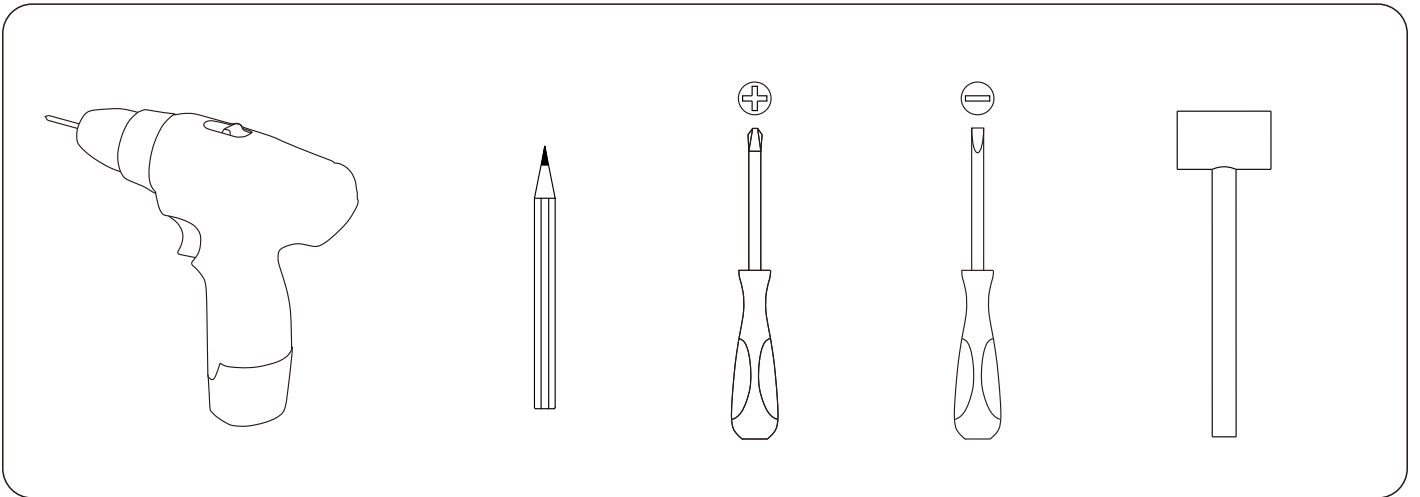

1

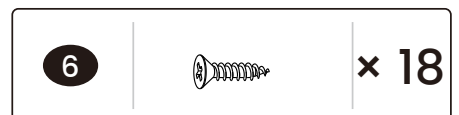
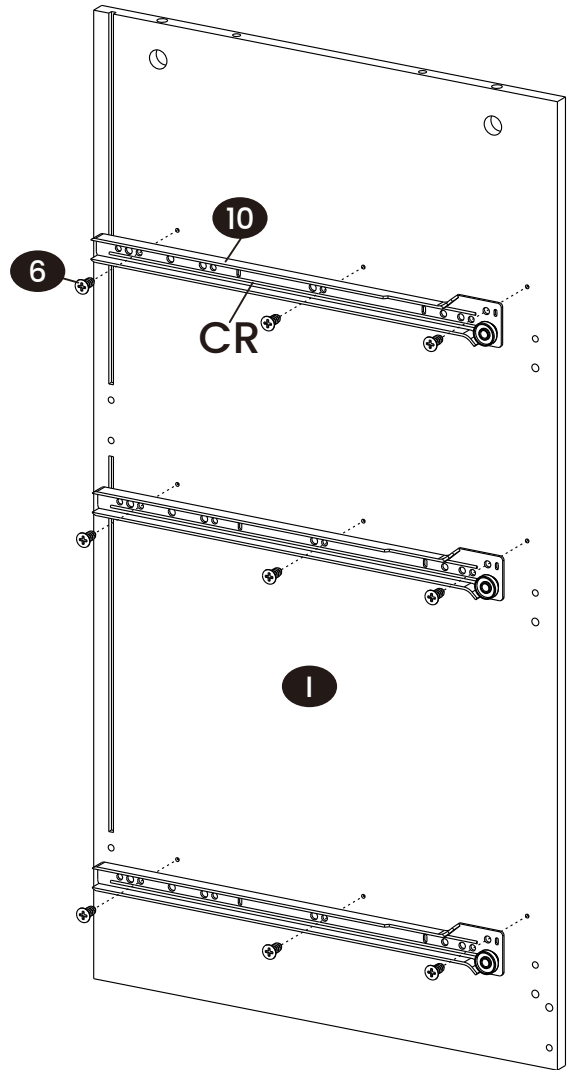
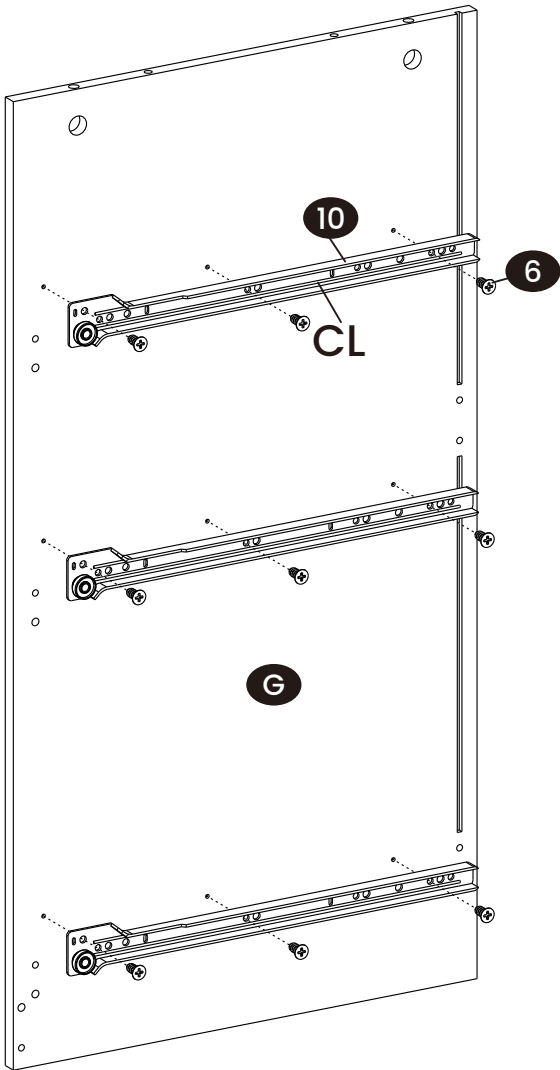
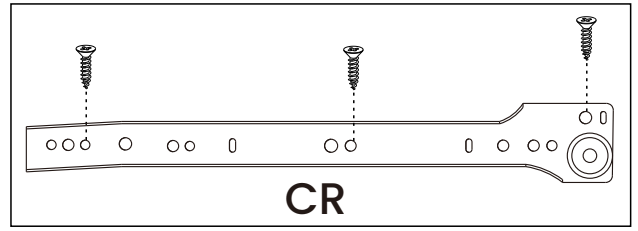
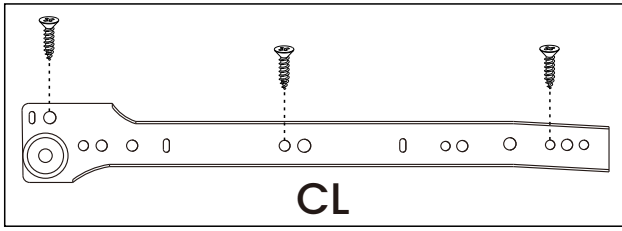

2

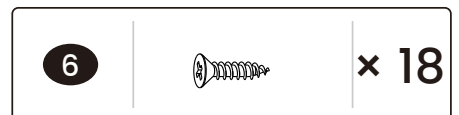
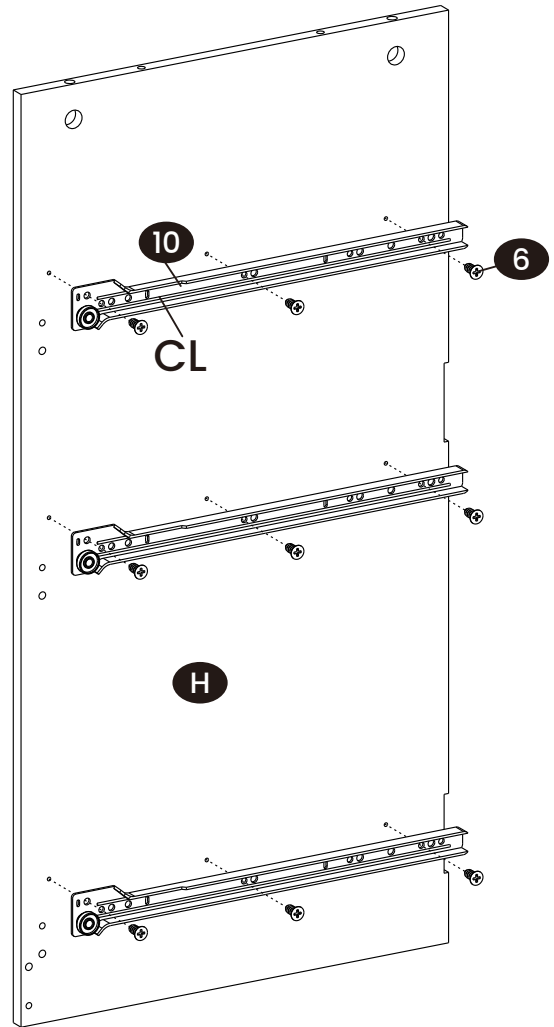
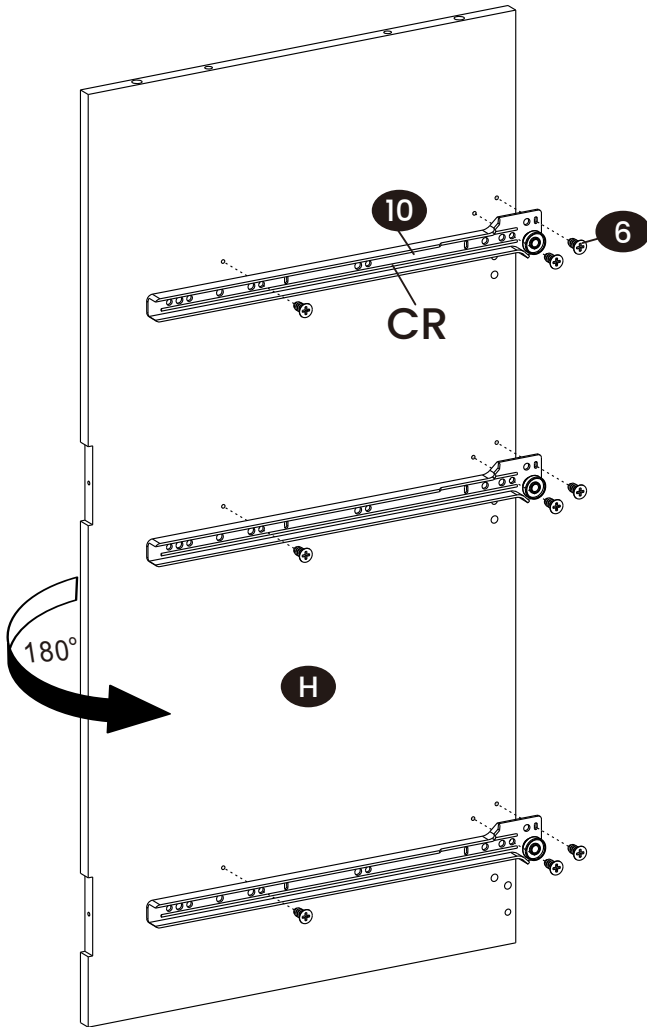
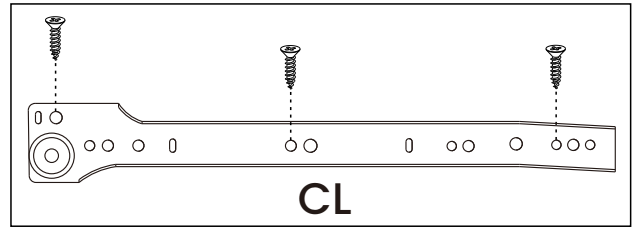
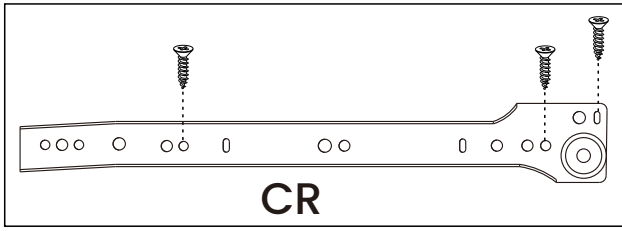

3

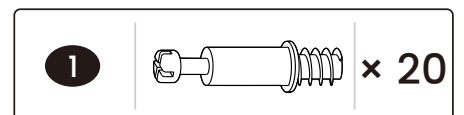
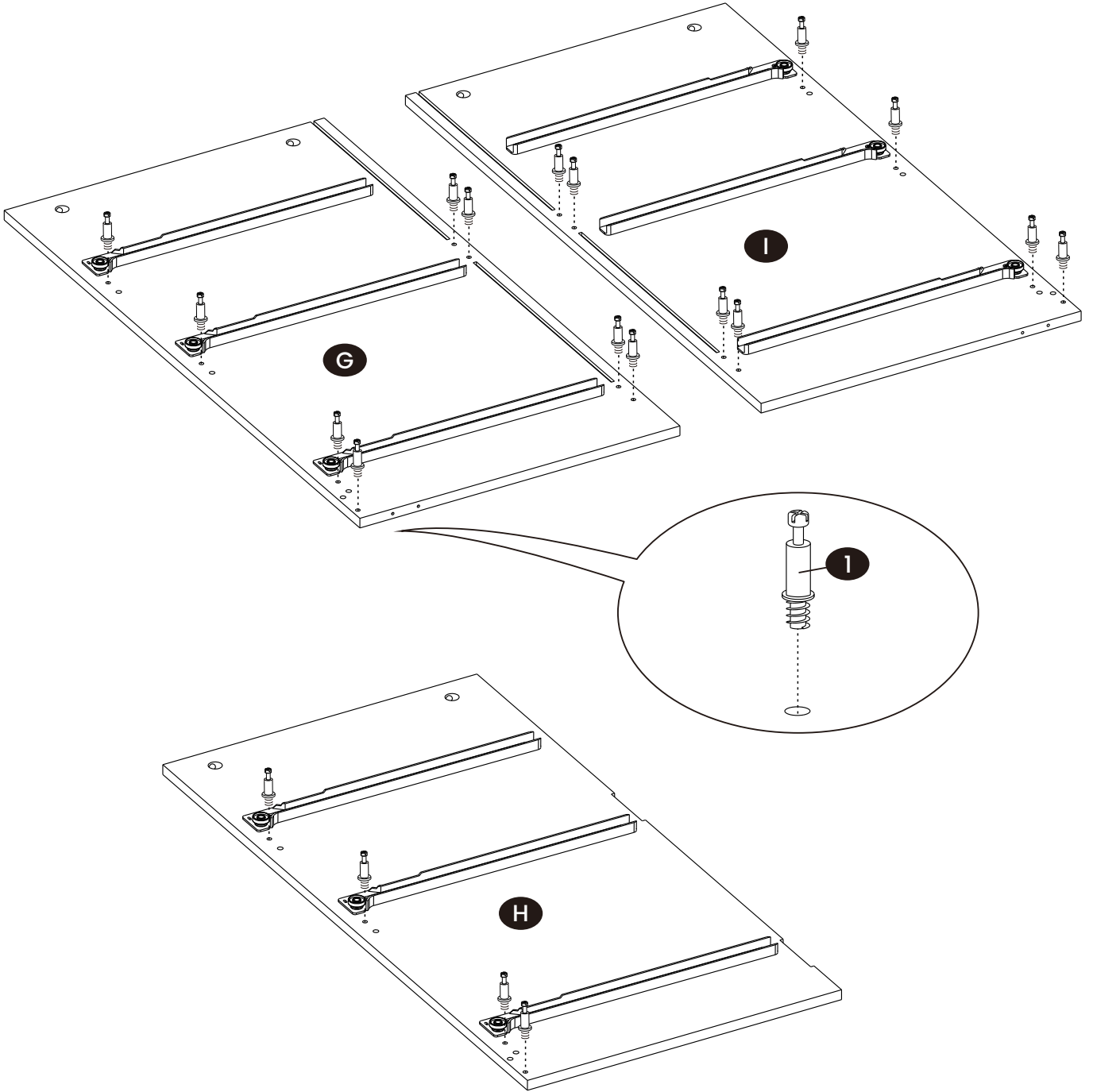

4

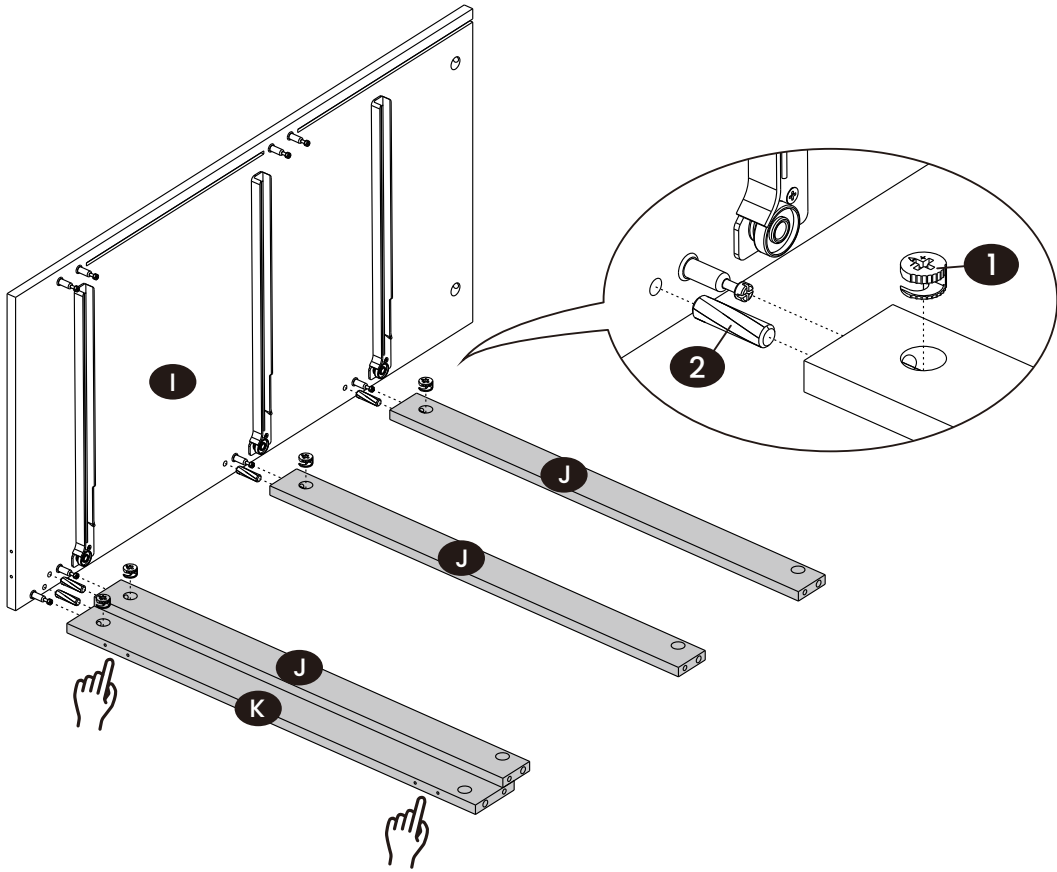

5

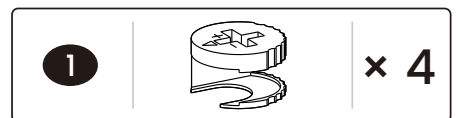
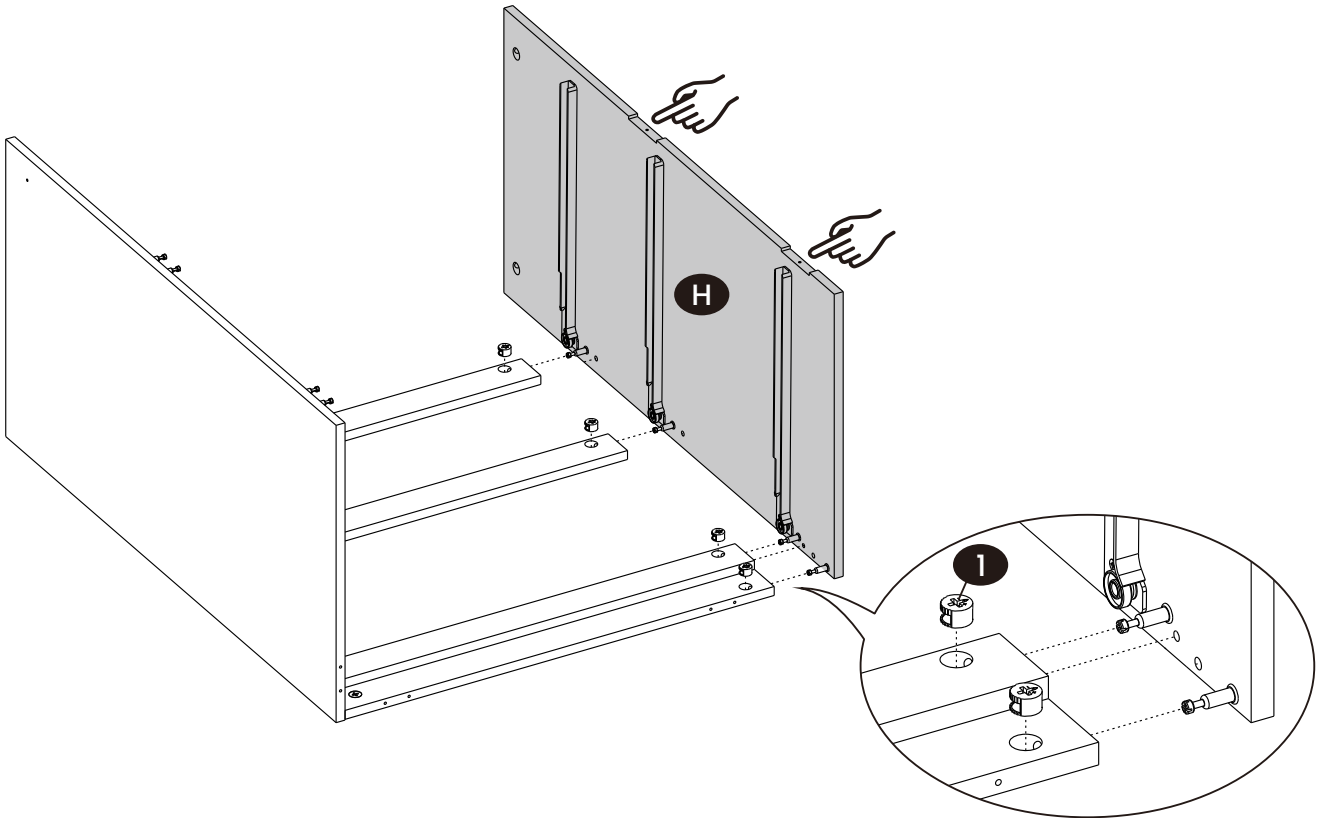

6

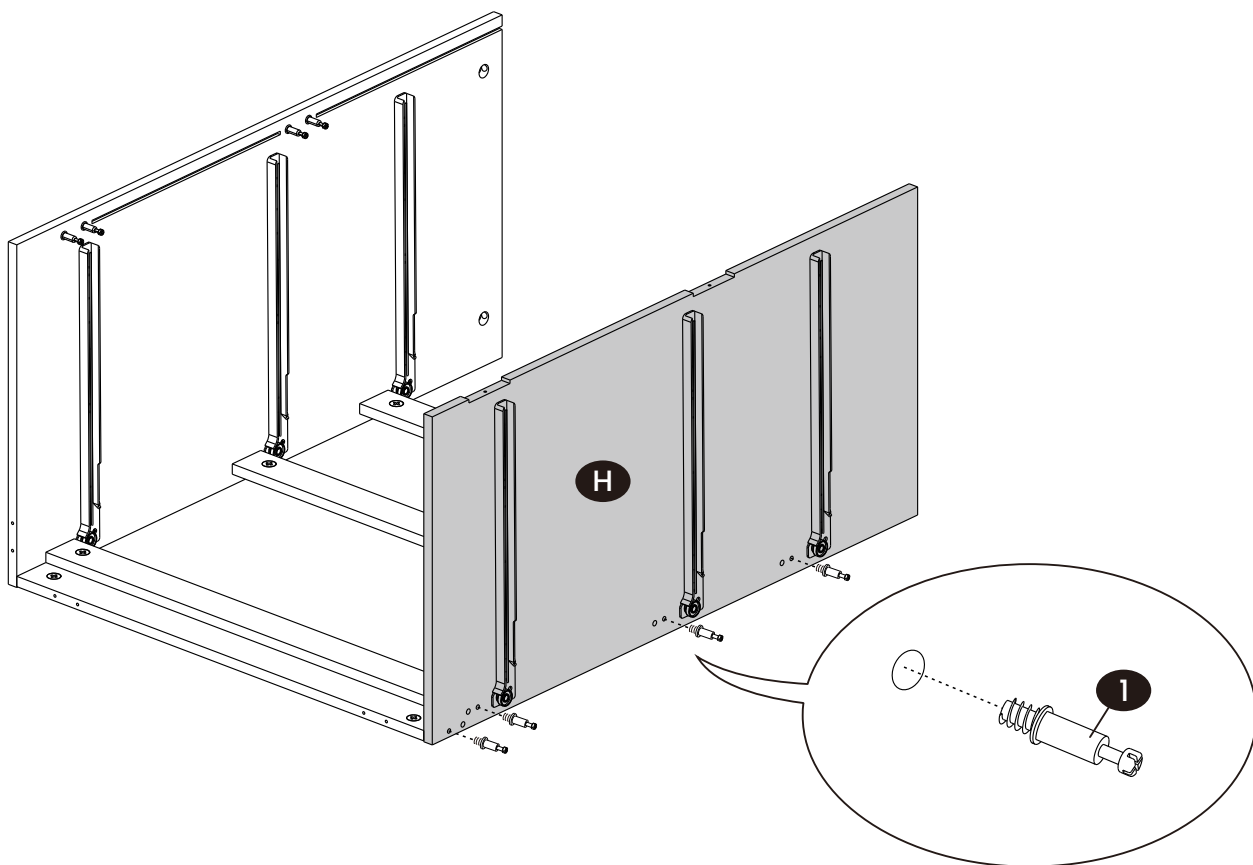

7

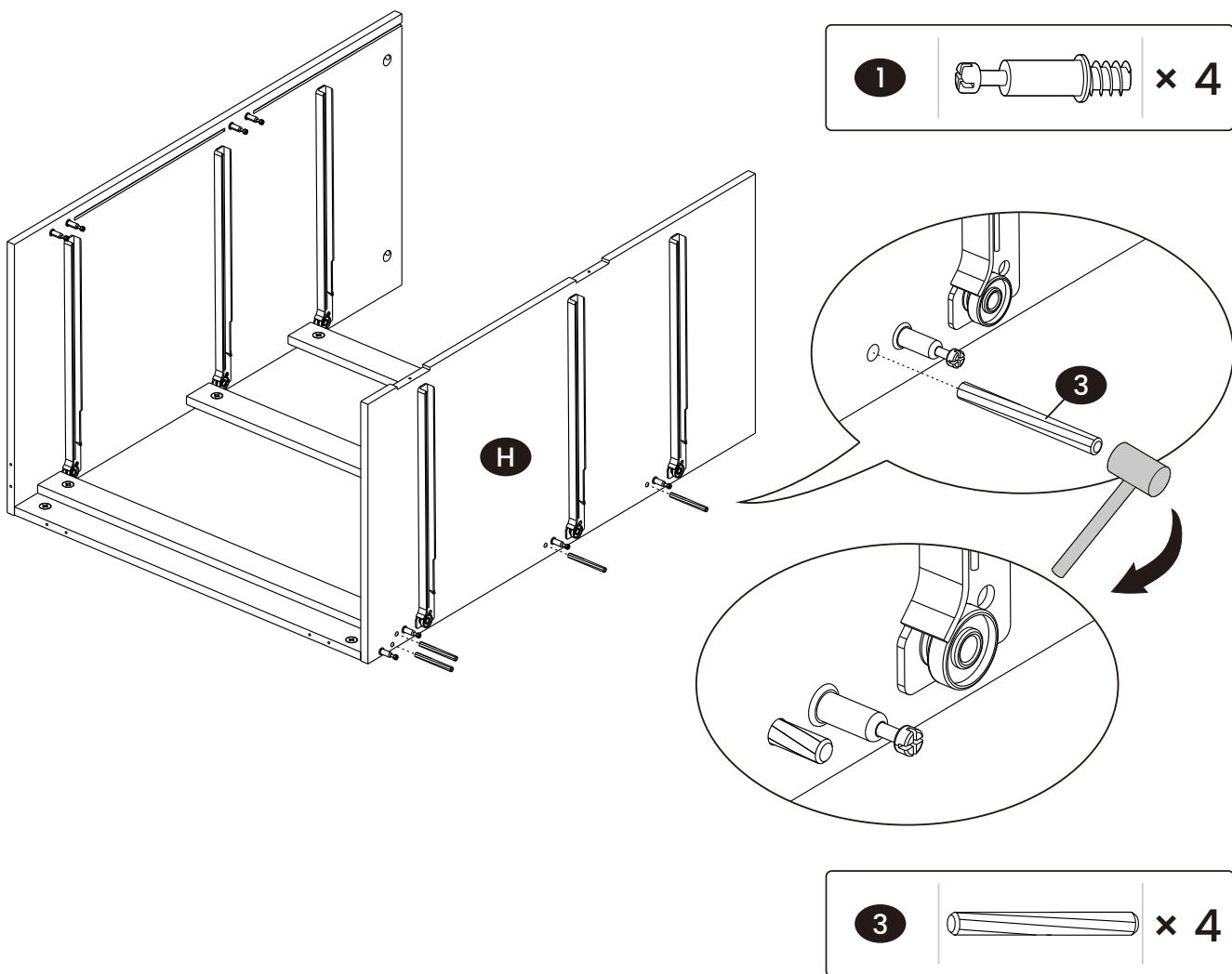

8

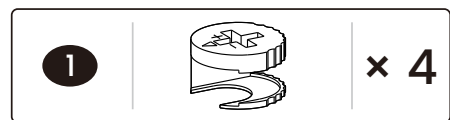
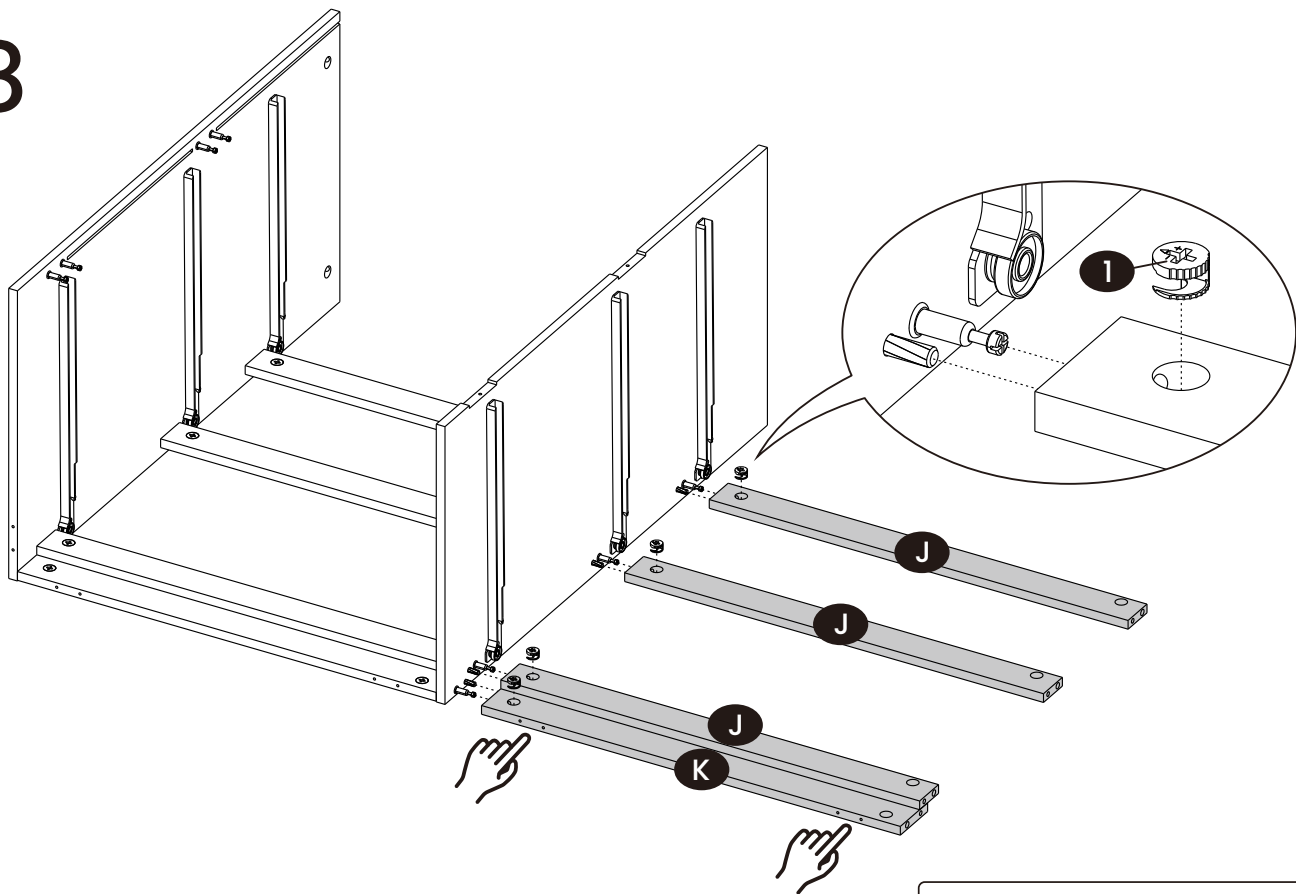

9

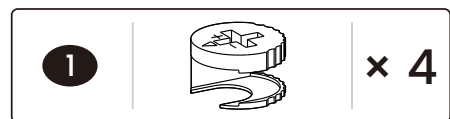
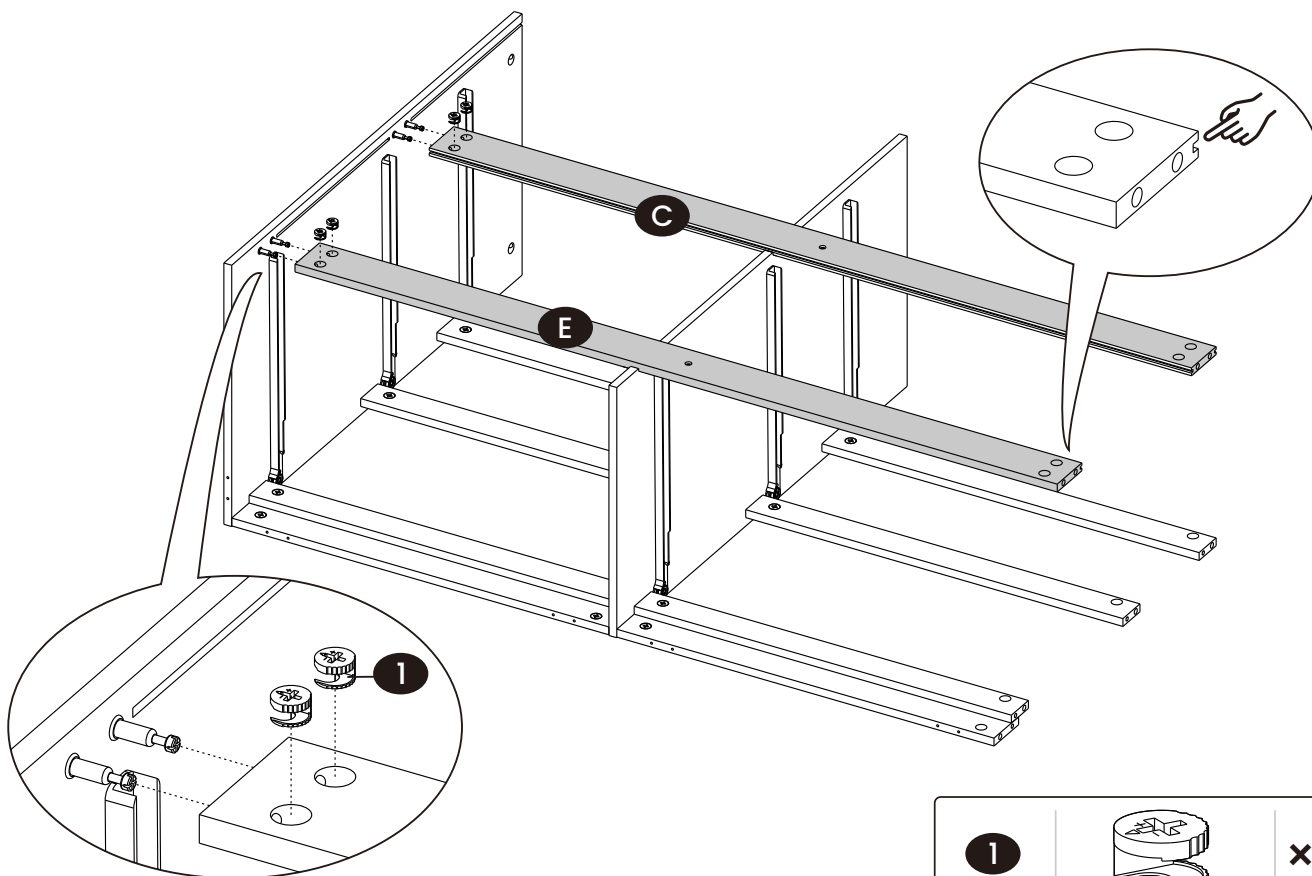

10

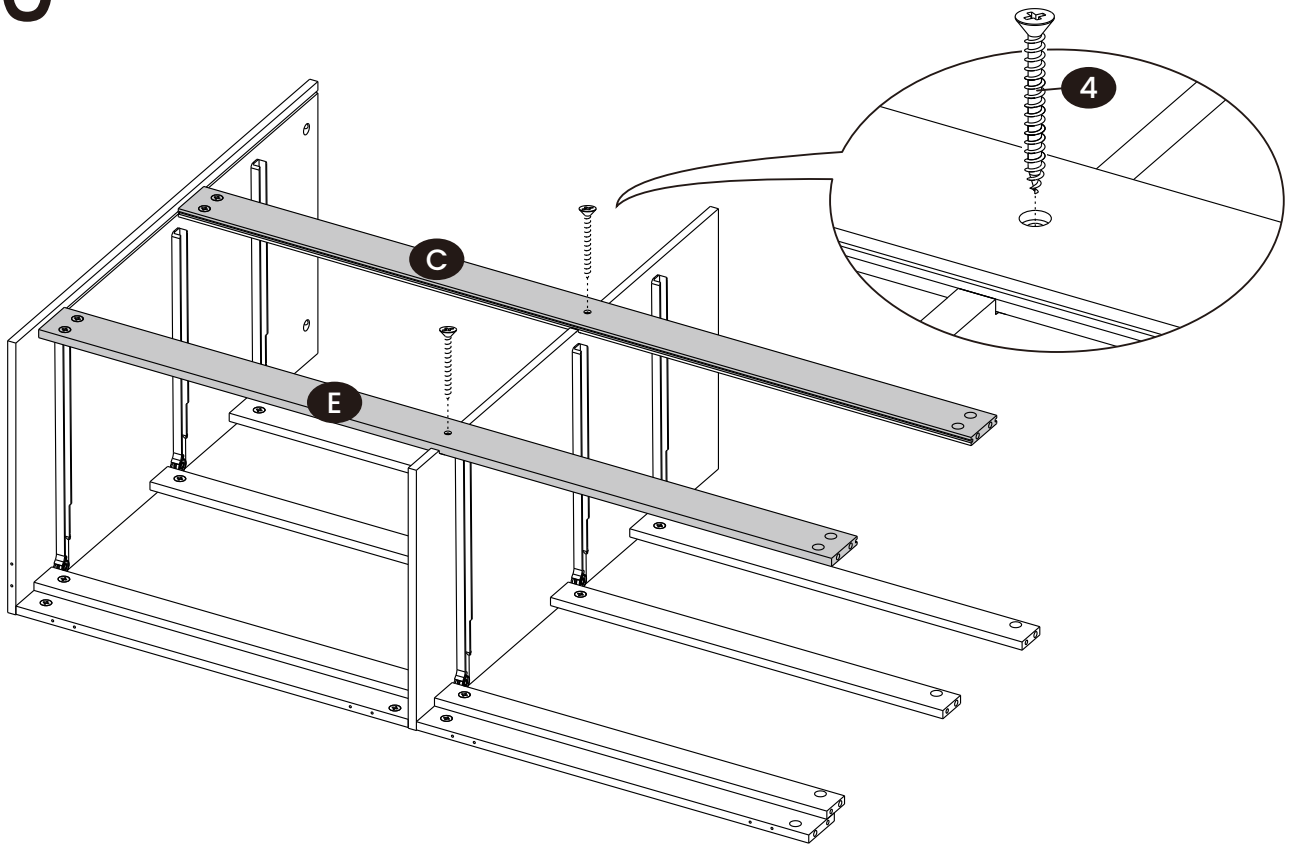

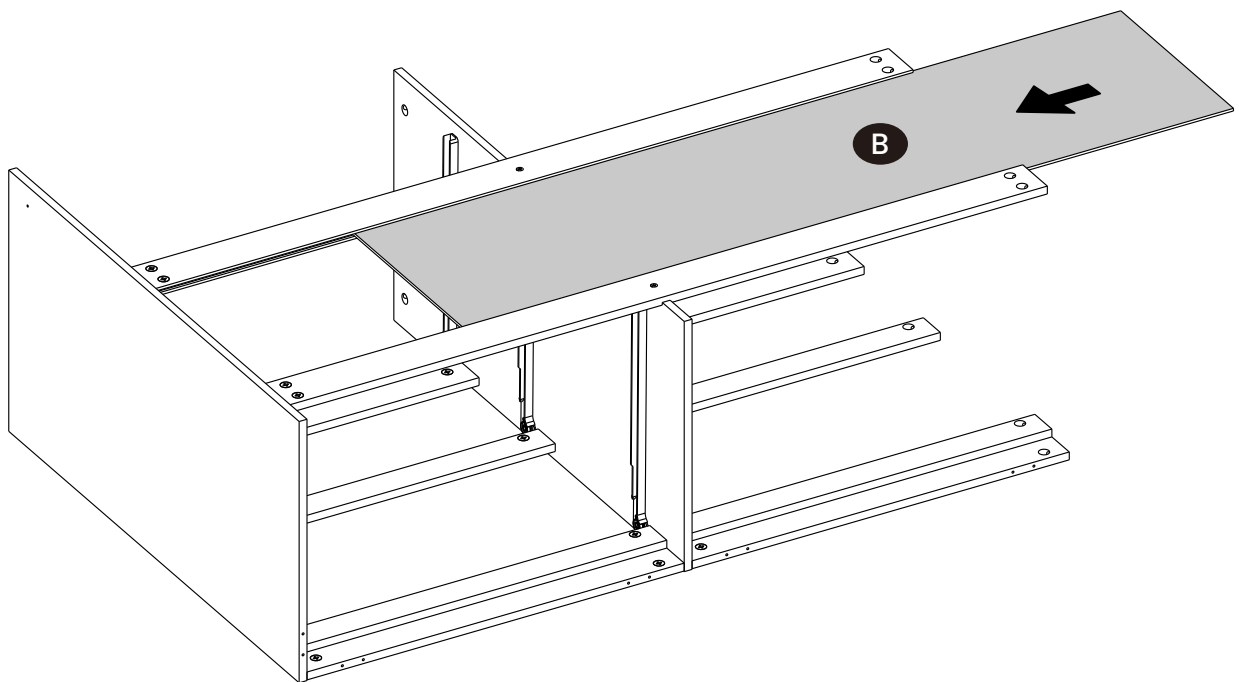
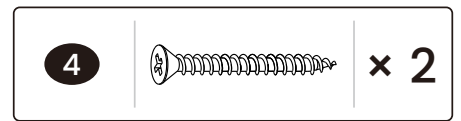

11

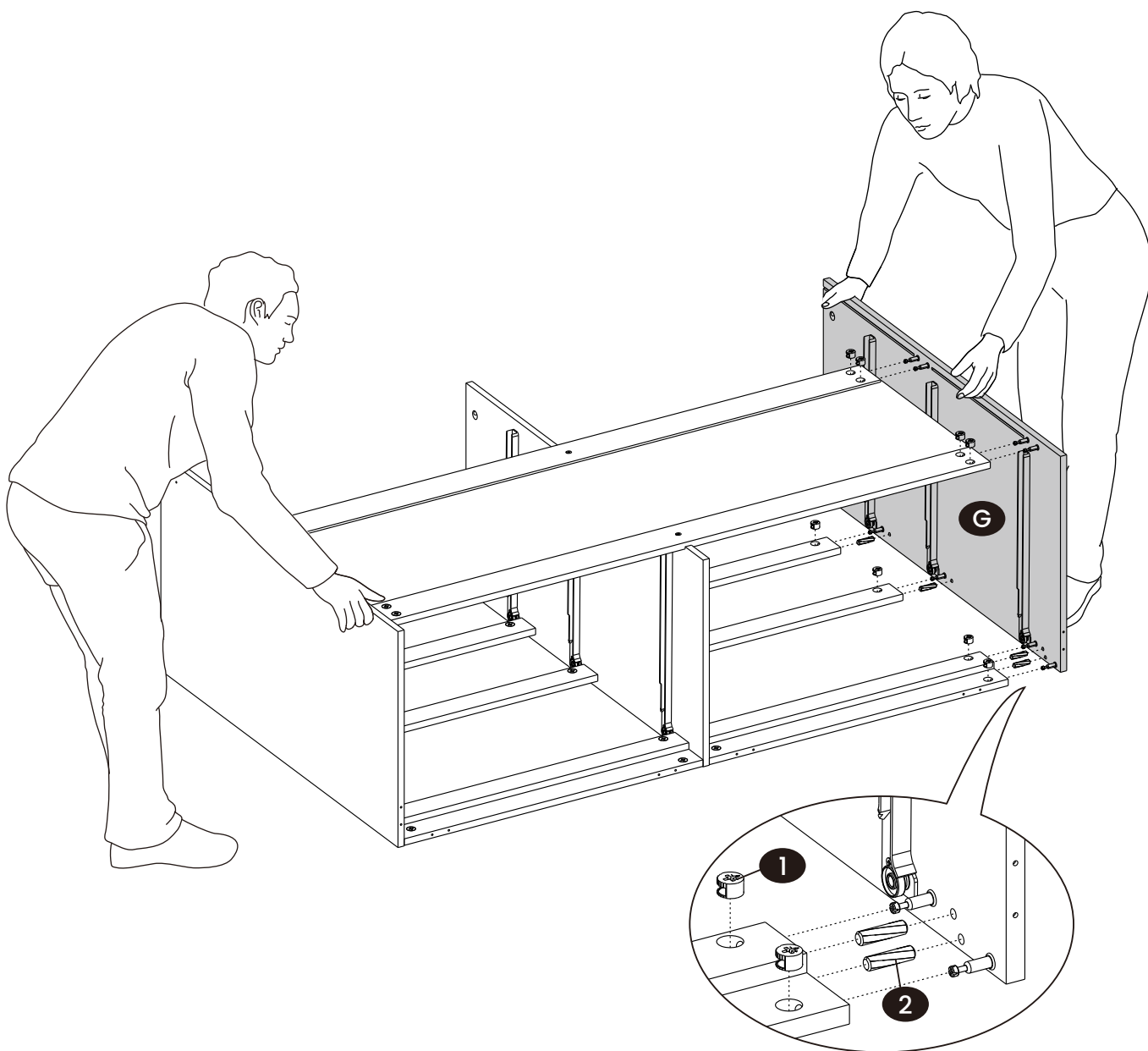

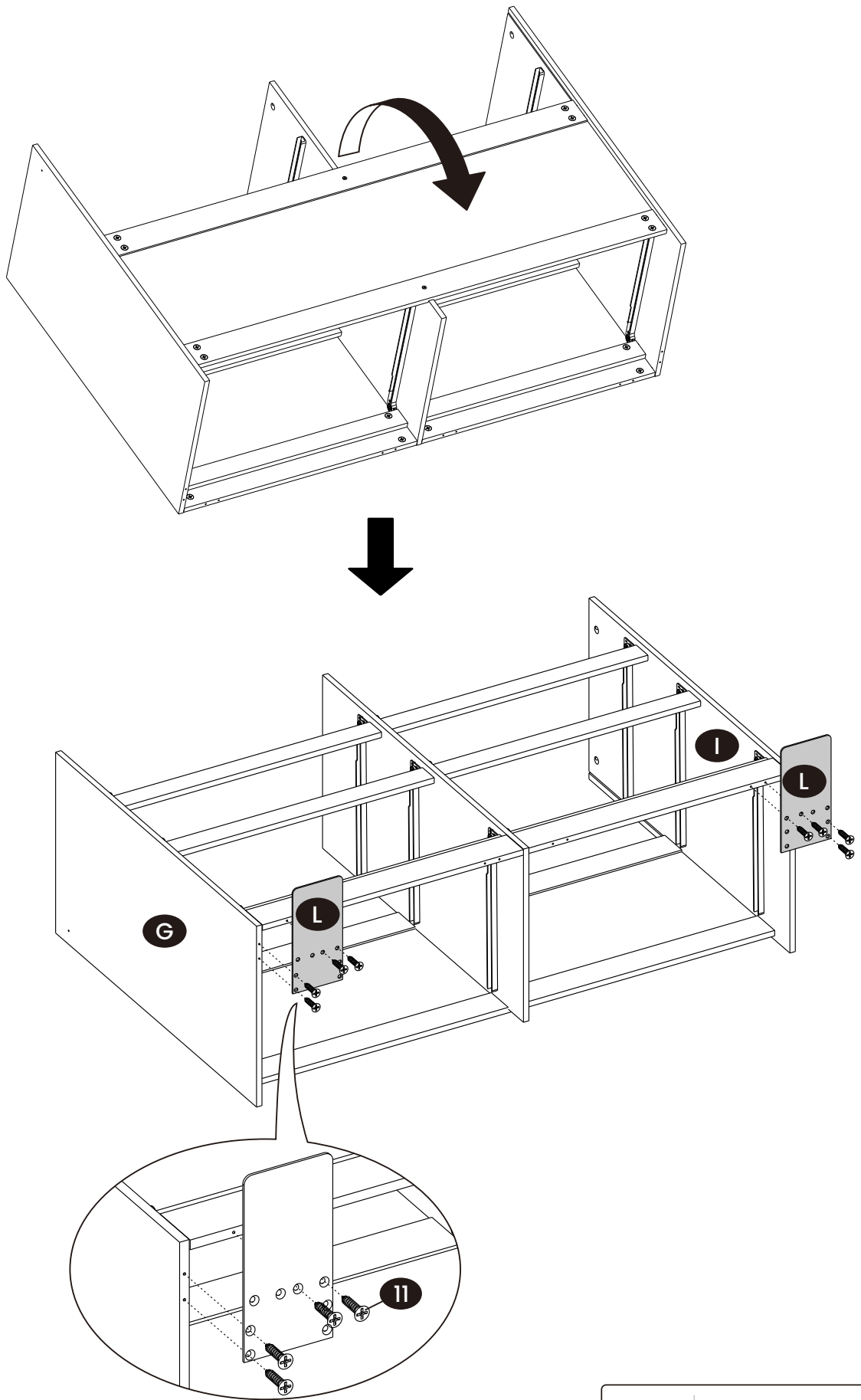

13



11		× 8
----	---	-----

14

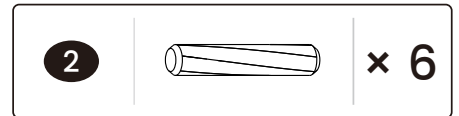
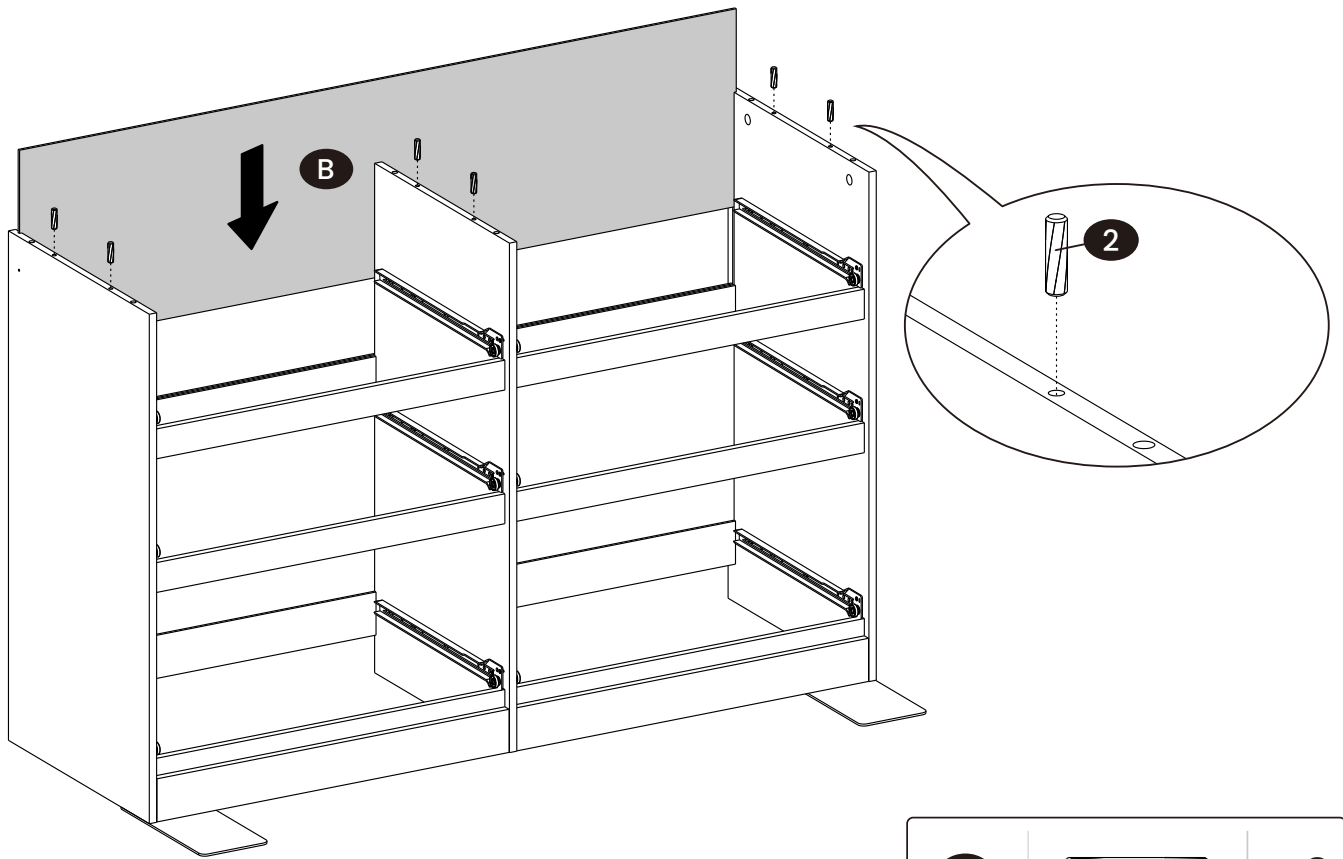

15

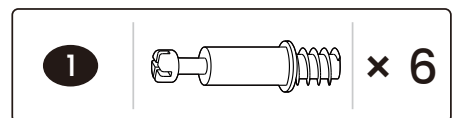
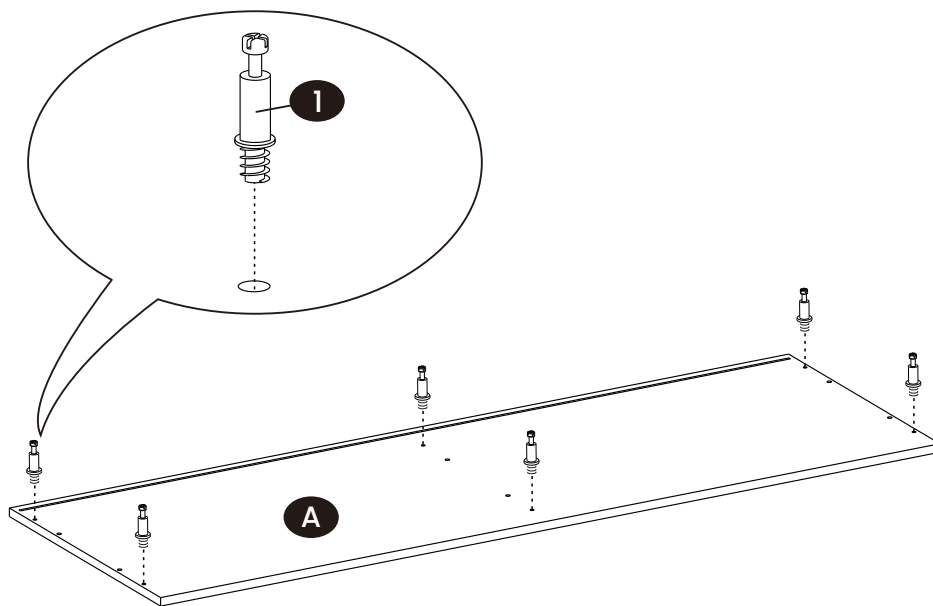

16

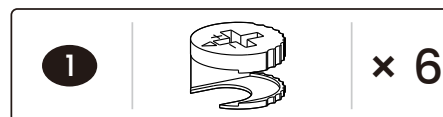
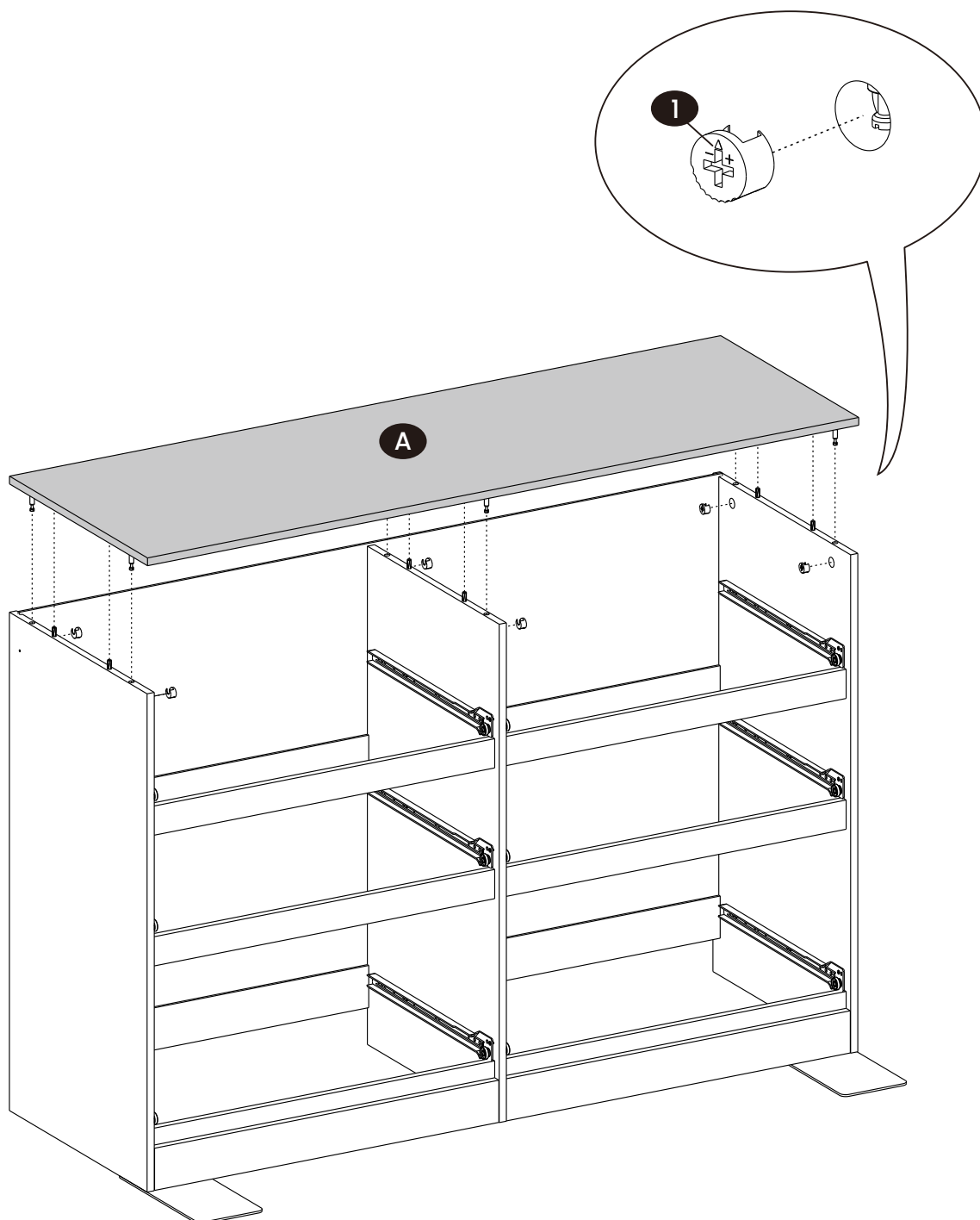

17

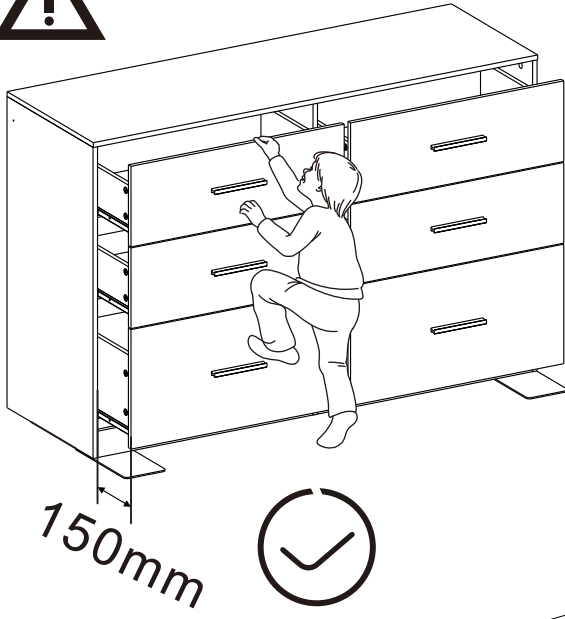

150mm

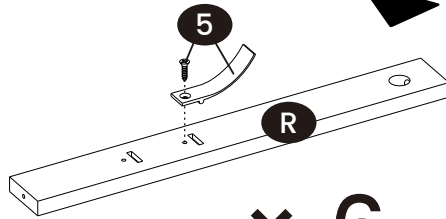
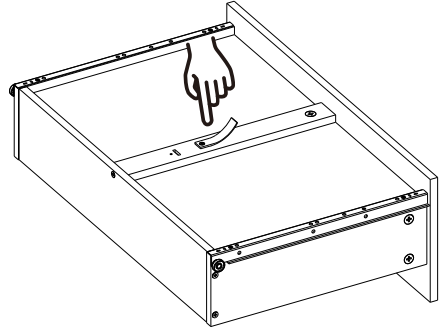
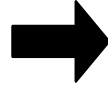

× 6

OR

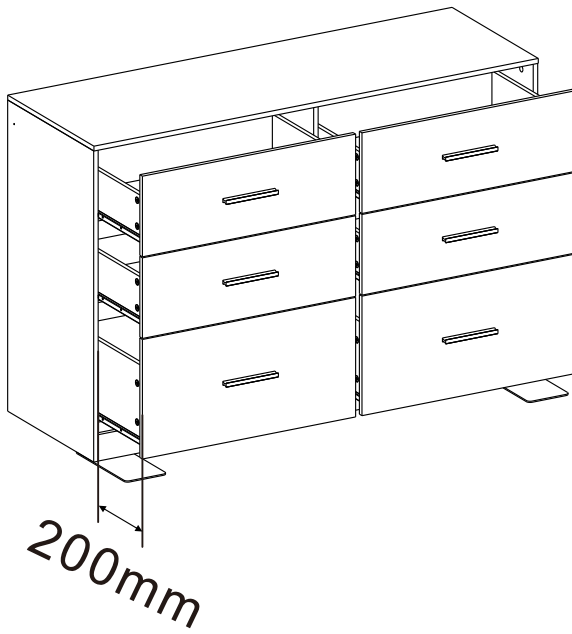

200mm

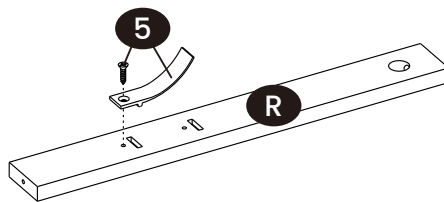
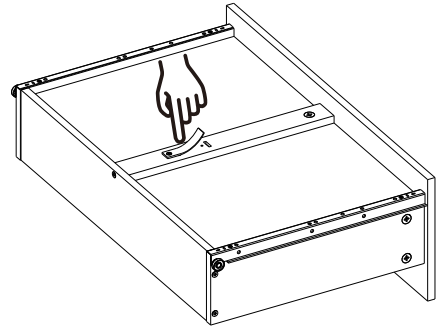
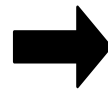

× 6

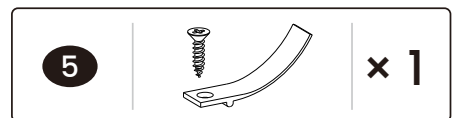

18

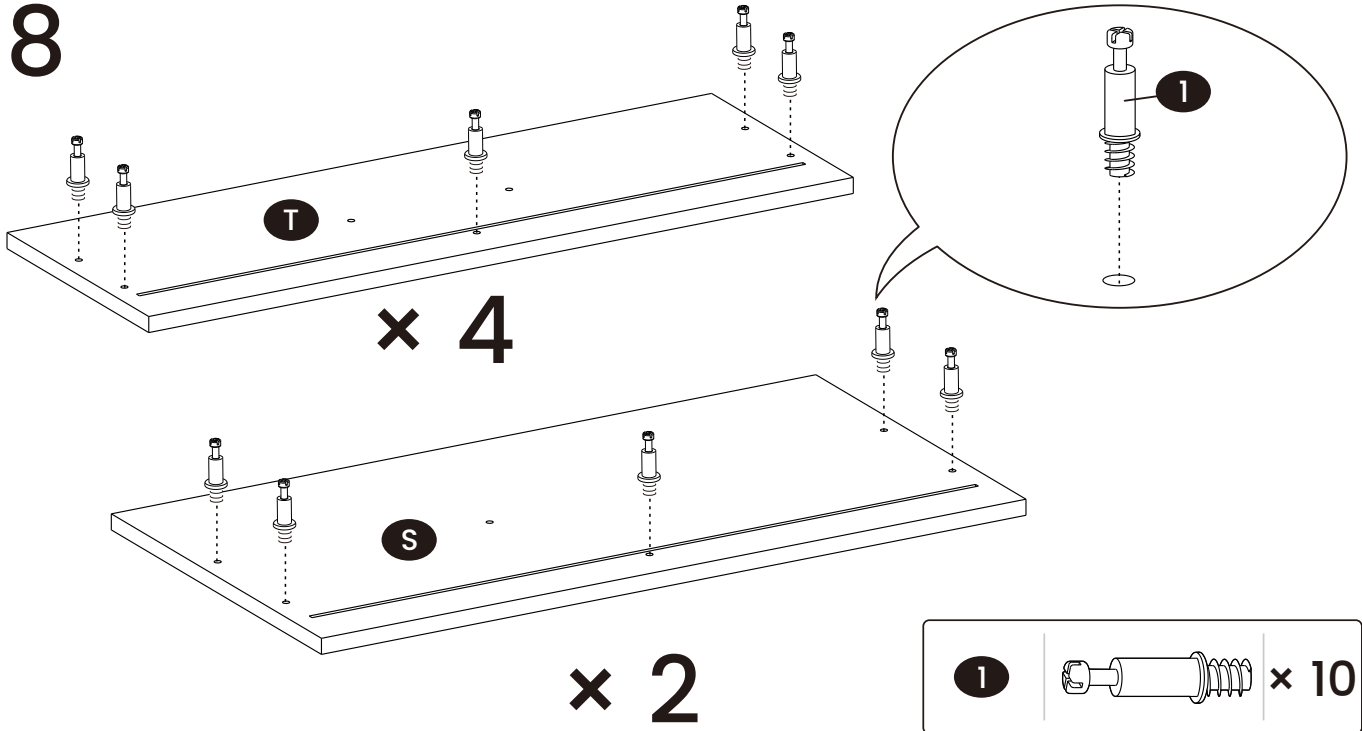

19

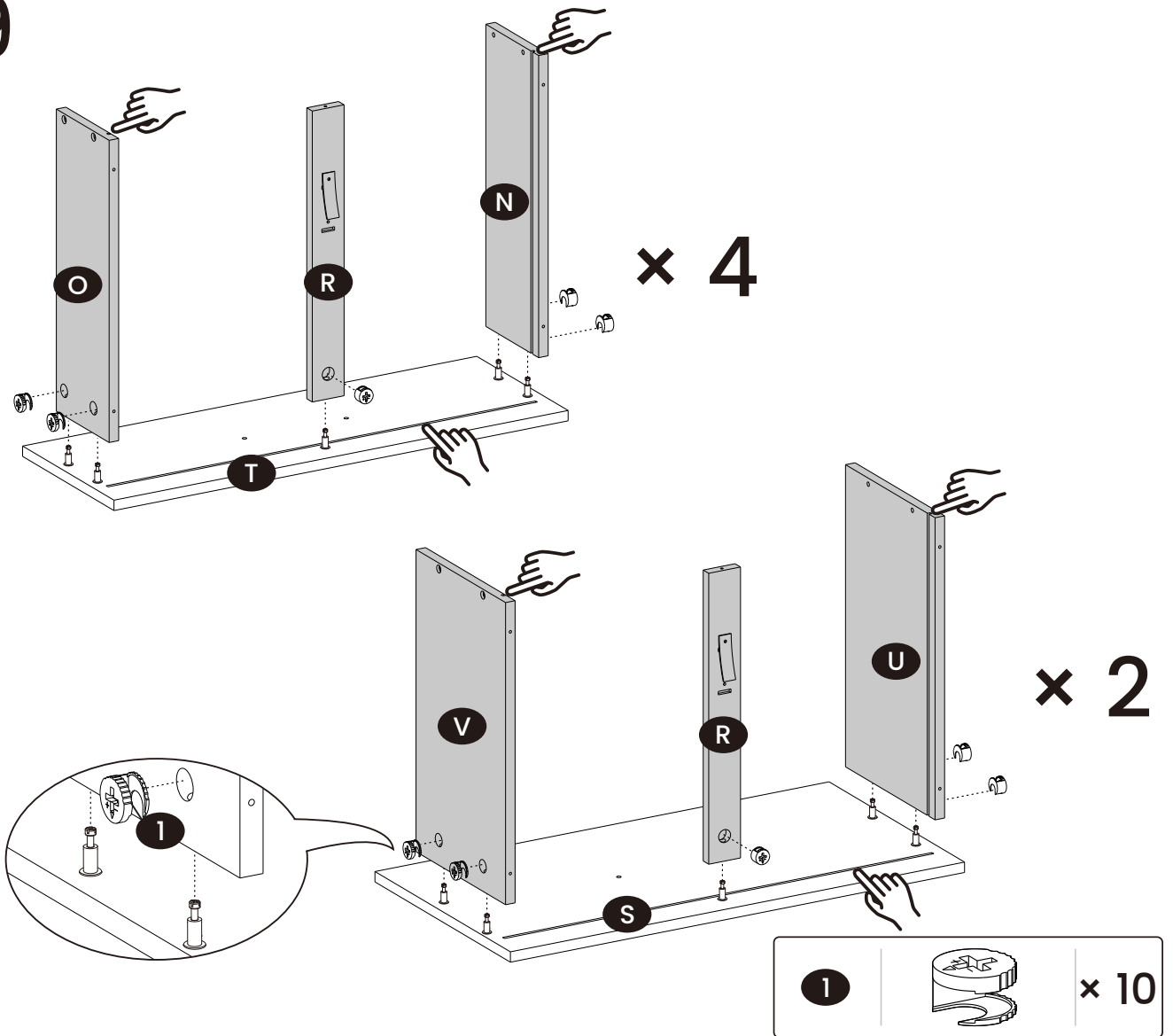

20

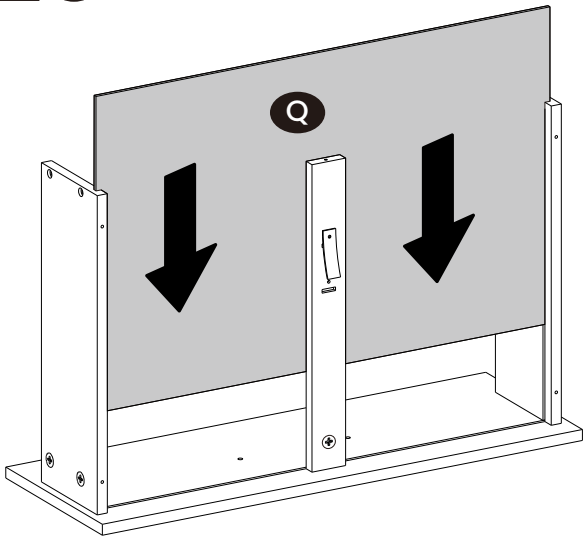

× 4

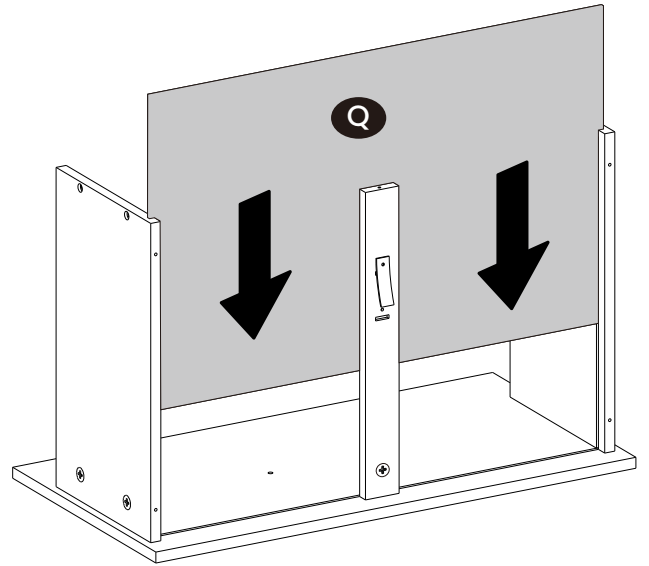

× 2

21

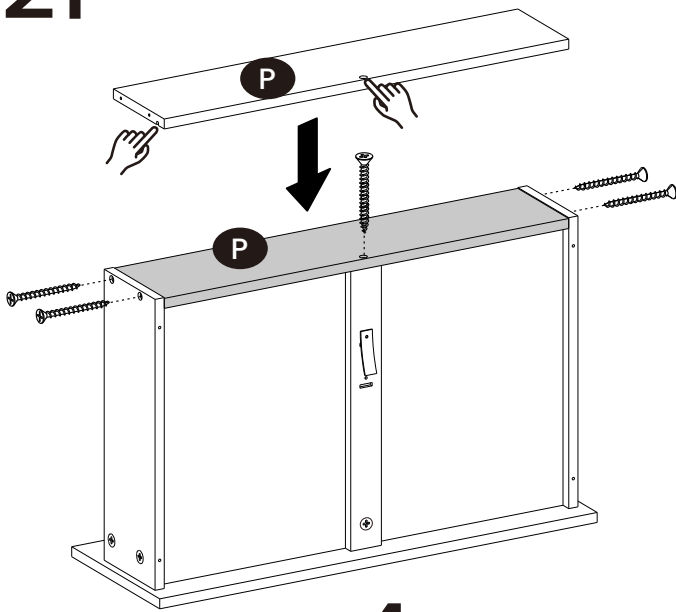

× 4

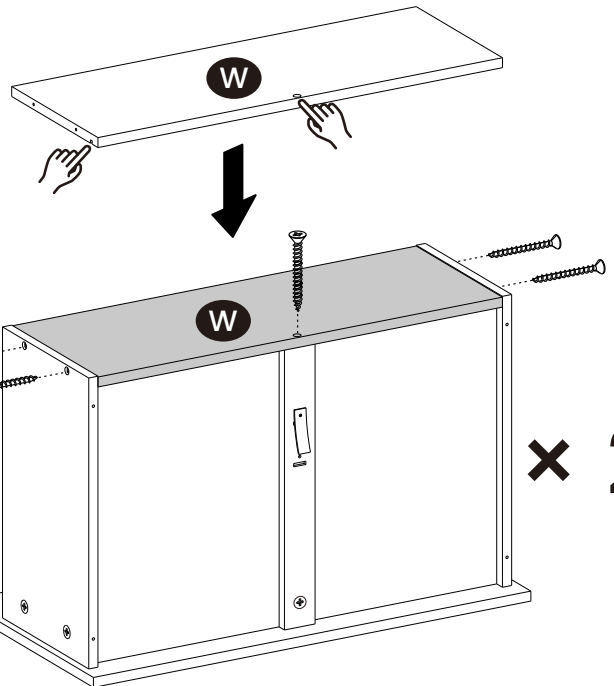

× 2

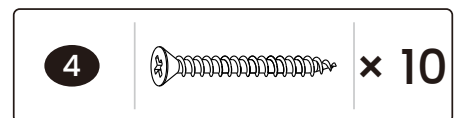
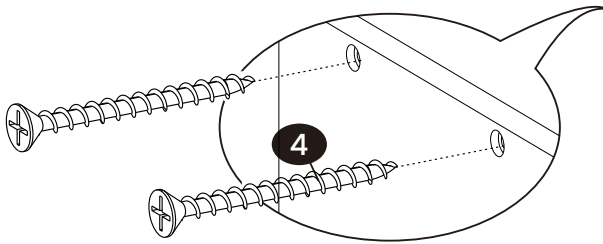

22

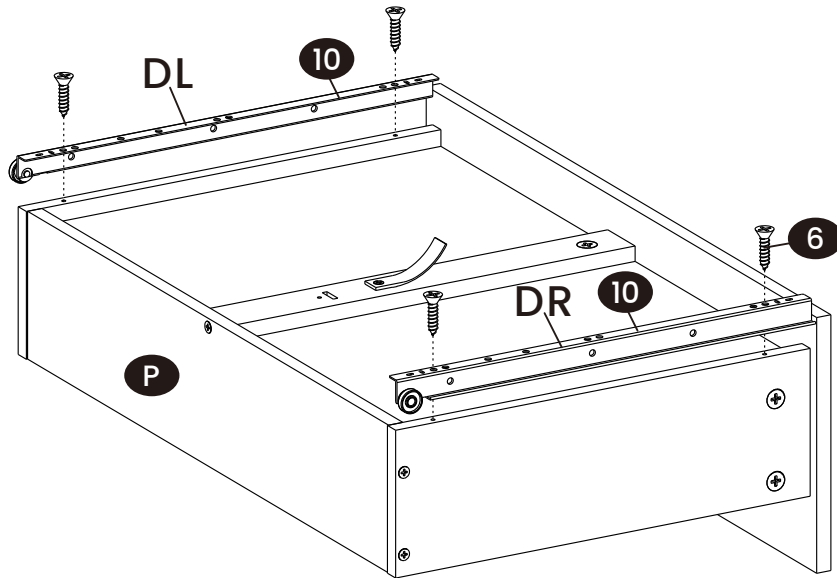
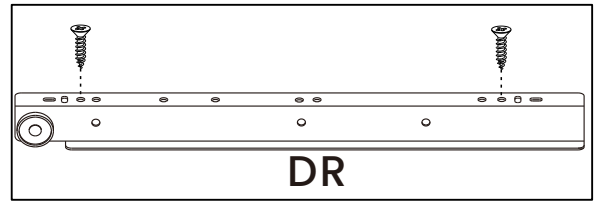
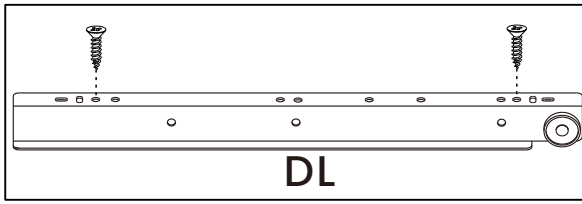

× 4

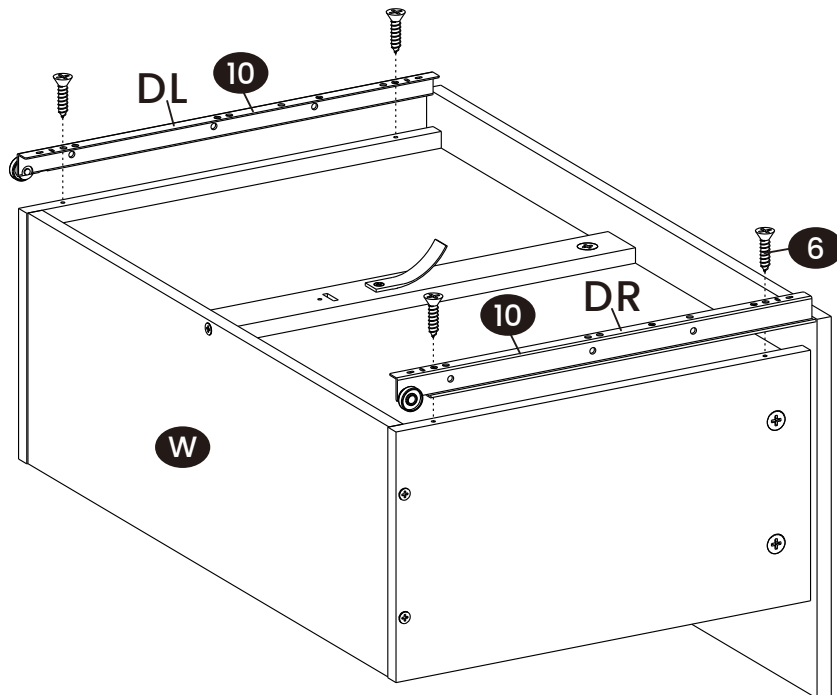

× 2

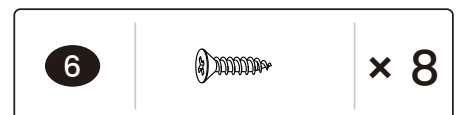

23

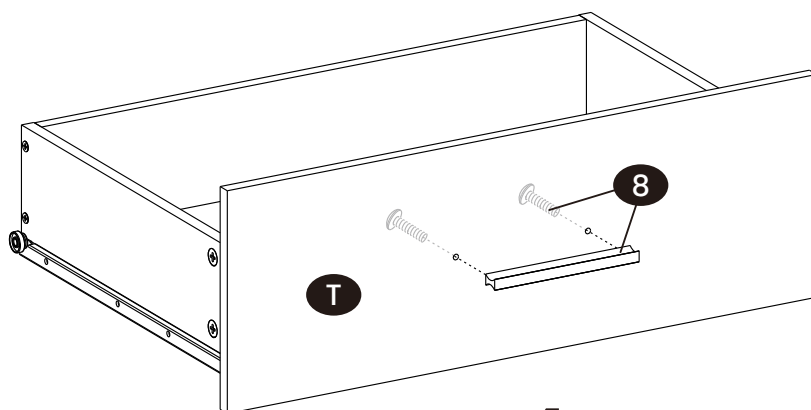

× 4

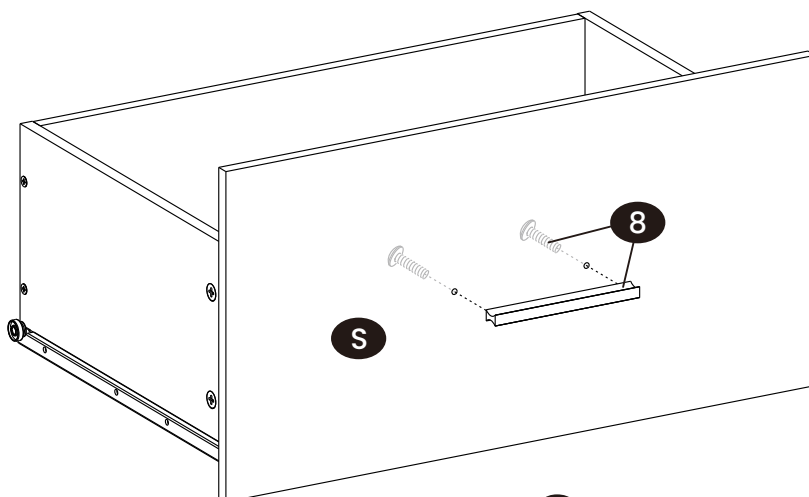

× 2

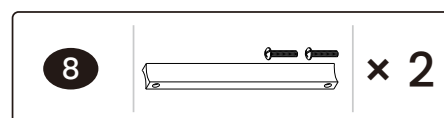

24

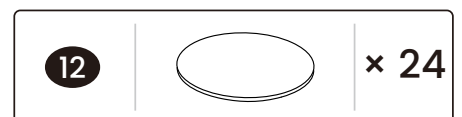
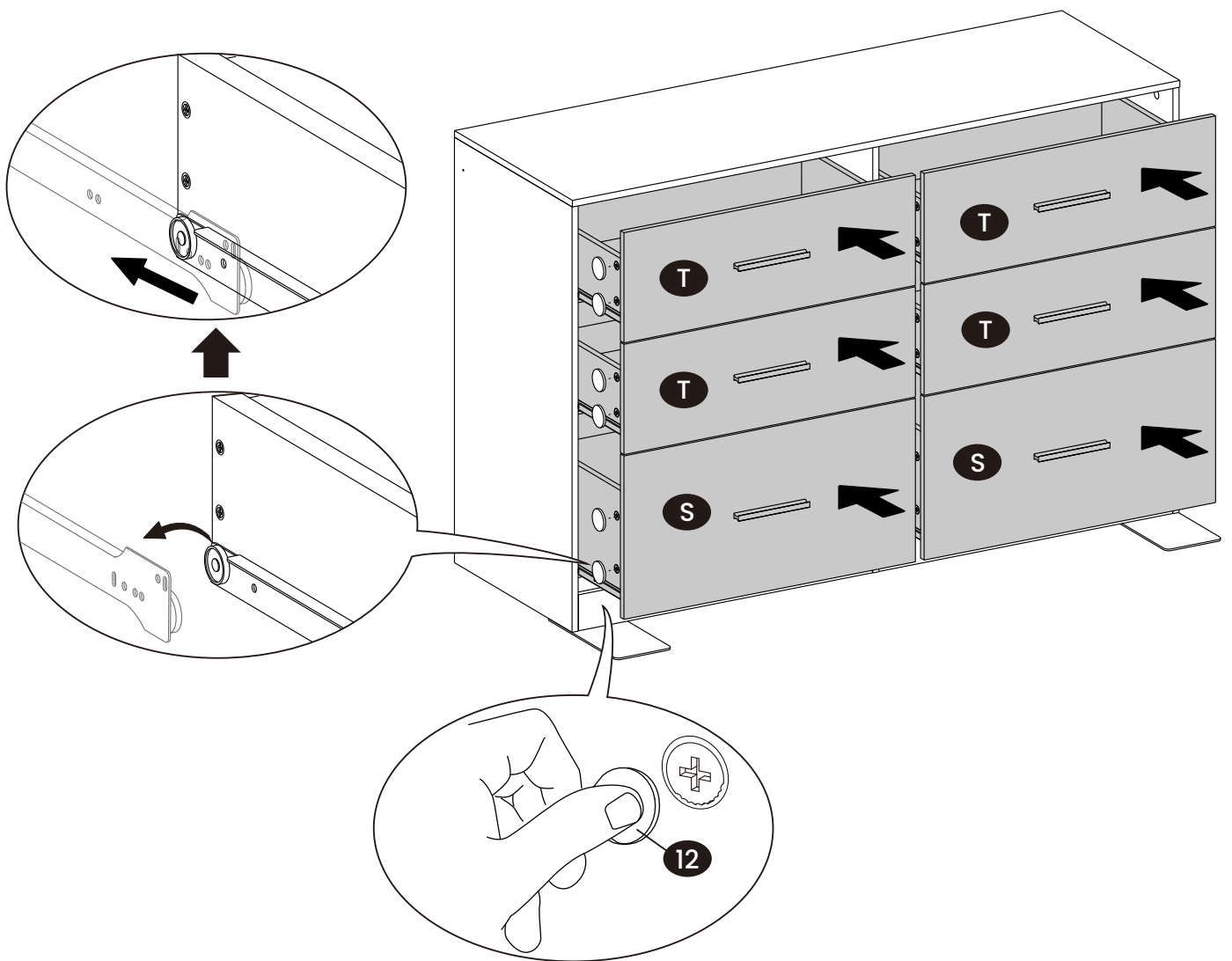

25

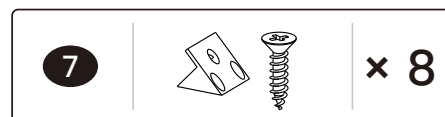
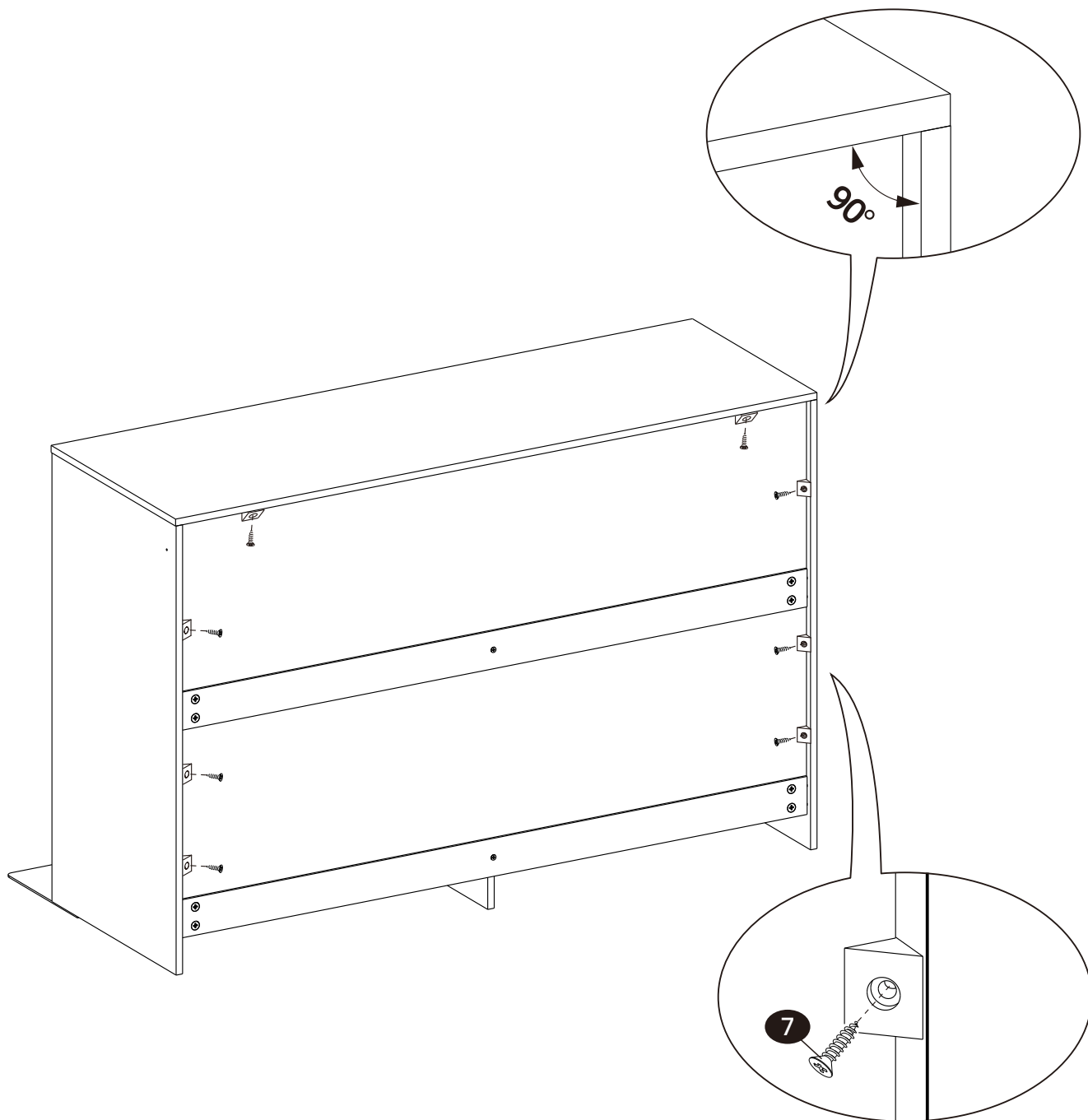

26

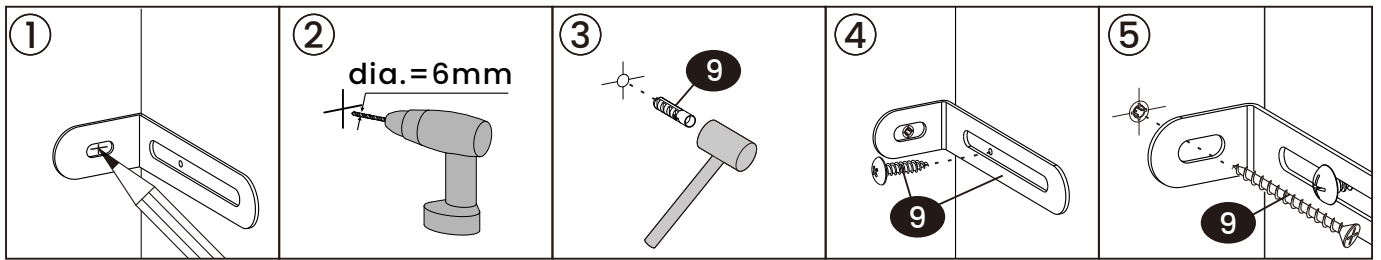

Move the dresser to the desired location. Use the pre-drilled holes for the anti-tip kit on the side panels as a guide to mark the positions on the wall.

Drill 2 holes in the wall, each approximately 6 mm (1/4 inch) in diameter and 40 mm (1.5") deep. Use a level to ensure the 2 holes are horizontally aligned.

Then, insert wall anchors and use screws to attach the anti-tip kit to the wall and dresser.

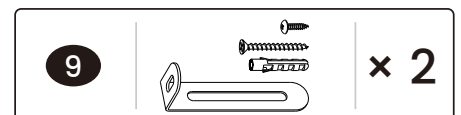
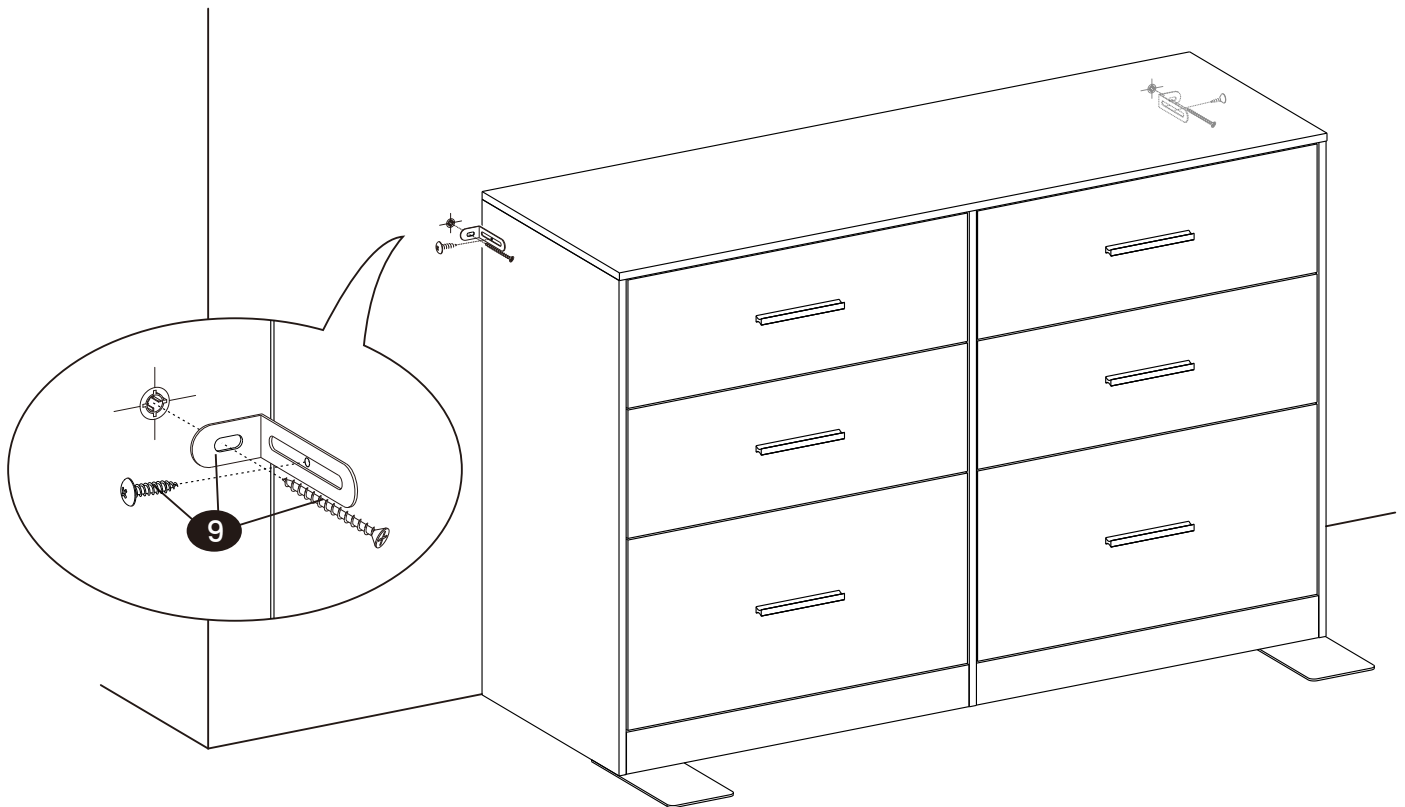

EN Warnings

Children are not allowed to assemble the product. During assembly, keep all small parts out of the reach of children as they may be fatal if swallowed or inhaled.

Children are forbidden to climb or play on the product to avoid serious bodily injury caused by the toppling.

Do not use the product unless the 2 metal plates at the bottom are assembled.

In order to prevent overturning, this product must be used with the wall attachment device provided.

Installation shall be carried out exactly according to the manufacturer's instructions; otherwise, a safety risk can occur if incorrectly installed.

If there are any defective or missing parts after unpacking, cease assembly immediately and contact us. Unauthorized change and modification may affect safety.

DE Warnhinweise

Kinder dürfen das Produkt nicht aufbauen. Bewahren Sie während der Montage alle Kleinteile außerhalb der Reichweite von Kindern auf. Verschlucken oder Einatmen kann tödlich sein.

Kinder dürfen nicht auf das Produkt klettern oder damit spielen, um schwere Verletzungen durch Umkippen zu vermeiden.

Verwenden Sie das Produkt nicht, wenn die beiden Metallplatten an der Unterseite nicht zusammengebaut sind.

Damit das Produkt nicht herunterfällt, muss es mit dem mitgelieferten Befestigungsset an der Wand gesichert werden.

Bauen Sie das Produkt exakt nach Anleitung auf, um Risiken aufgrund fehlerhafter Installation zu vermeiden.

Sollten nach dem Auspacken ein oder mehrere Teile beschädigt sein und/oder fehlen, brechen Sie bitte die Montage sofort ab und setzen Sie sich mit uns in Verbindung. Unbefugte Änderungen und Modifikationen können die Sicherheit beeinträchtigen.

FR Avertissements

Il est interdit aux enfants d'assembler le produit. Pendant l'assemblage, gardez toutes les petites pièces hors de la portée des enfants car elles peuvent être mortelles en cas d'ingestion ou d'inhalation.

Il est interdit aux enfants de grimper ou de jouer sur le produit pour éviter de graves blessures corporelles causées par le renversement.

Les supports métalliques des pieds sont des éléments indispensables et doivent impérativement être montés. L'utilisation du produit sans ces supports est strictement interdite.

Afin d'éviter tout risque de basculement, ce produit doit être utilisé avec le dispositif anti-basculement murale fourni.

Veillez installer le produit en suivant strictement les instructions du fabricant. Une installation incorrecte peut entraîner un risque pour la sécurité.

En cas de pièces défectueuses ou manquantes après le déballage, arrêtez immédiatement l'assemblage et contactez-nous. Tout changement ou modification non autorisé peut affecter la sécurité.

IT Avvertenze

I bambini non sono autorizzati a montare il prodotto. Durante il montaggio, tenere tutte le piccole parti fuori dalla portata dei bambini poiché potrebbero essere fatali se ingerite o inalate.

È vietato ai bambini arrampicarsi o giocare sul prodotto per evitare gravi lesioni corporee causate dal ribaltamento.

Le piastre metalliche dei piedini sono componenti obbligatori e devono essere installate. È vietato utilizzare il prodotto senza averle montate.

Per evitare il ribaltamento, questo prodotto deve essere utilizzato con il dispositivo di fissaggio a parete fornito.

L'installazione deve essere eseguita esattamente secondo le istruzioni del produttore, altrimenti può verificarsi un rischio per la sicurezza in caso di installazione errata.

Se dopo aver aperto la confezione ci sono parti difettose o mancanti, interrompere immediatamente il montaggio e contattarci. Modifiche non autorizzate possono compromettere la sicurezza.

ES Advertencias

No está permitido que los niños monten el producto. Durante el montaje, mantenga todas las piezas pequeñas fuera del alcance de los niños, ya que pueden ser mortales si se ingieren o inhalan.

Se prohíbe a los niños trepar o jugar sobre el producto para evitar lesiones corporales graves causadas por el vuelco.

Las placas metálicas de las patas son componentes obligatorios y deben ser instaladas. Está prohibido utilizar el producto sin haberlas montado.

Para evitar el vuelco, este producto debe utilizarse con el dispositivo de fijación a la pared suministrado.

La instalación debe realizarse siguiendo exactamente las instrucciones del fabricante; de lo contrario, puede producirse un riesgo para la seguridad si se instala incorrectamente.

Si hay alguna pieza defectuosa o falta alguna pieza después de desembalar, interrumpa el montaje inmediatamente y póngase en contacto con nosotros. Los cambios y modificaciones no autorizados pueden afectar a la seguridad.

NL Waarschuwingen

Kinderen mogen het product niet monteren. Houd tijdens de montage alle kleine onderdelen buiten het bereik van kinderen, omdat deze dodelijk kunnen zijn als ze worden ingeslikt of ingeademd.

Kinderen mogen niet op het product klimmen of ermee spelen om ernstig lichamelijk letsel door omvallen te voorkomen.

De metalen voetplaatonderdelen zijn verplichte componenten die moeten worden geïnstalleerd. Het product mag niet worden gebruikt als deze onderdelen niet zijn gemonteerd.

Om omvallen te voorkomen, moet dit product worden gebruikt met het meegeleverde wandbevestigingssysteem.

Installatie dient exact volgens de instructies van de fabrikant te worden uitgevoerd, anders kan er bij onjuiste installatie een veiligheidsrisico ontstaan.

Als er defecte of ontbrekende onderdelen zijn na het uitpakken, stop dan onmiddellijk met monteren en neem contact met ons op. Ongeautoriseerde wijzigingen kunnen de veiligheid beïnvloeden.

SE Varningar

Barn får inte montera produkten. Under montering ska alla små delar hållas utom räckhåll för barn, eftersom de kan vara dödliga om de sväljs eller inandas.

Barn får inte klättra eller leka på produkten för att undvika allvarliga kroppsskador orsakade av omkullvänting.

De metalliska fotplåtsdelarna är obligatoriska komponenter som måste installeras. Produkten får inte användas om dessa delar inte är monterade.

För att förhindra att produkten välter måste den användas med den medföljande väggfästes anordningen.

Installation ska utföras exakt enligt tillverkarens anvisningar, annars kan en säkerhetsrisk uppstå vid felaktig installation.

Om det finns defekta eller saknade delar efter uppackning, avbryt omedelbart monteringen och kontakta oss. Obehöriga ändringar kan påverka säkerheten.

PL Ostrzeżenia

Dzieciom nie wolno montować produktu. Podczas montażu należy trzymać wszystkie drobne elementy poza zasięgiem dzieci, ponieważ mogą być śmiertelne w przypadku połknięcia lub wdychania.

Dzieciom zabrania się wspinania się lub zabawy na produkcie, aby uniknąć poważnych obrażeń spowodowanych przewróceniem się.

Metalowe płytki na spodzie są obowiązkowymi elementami, które muszą być zamontowane. Produktu nie wolno używać bez ich instalacji.

Aby zapobiec przewróceniu, produkt musi być używany z dołączonym urządzeniem mocującym do ściany.

Montaż powinien być przeprowadzony dokładnie zgodnie z instrukcją producenta, w przeciwnym razie w przypadku nieprawidłowego montażu może wystąpić ryzyko dla bezpieczeństwa.

Jeśli po rozpakowaniu są jakiegokolwiek wadliwe lub brakujące części, natychmiast przerwij montaż i skontaktuj się z nami. Nieautoryzowane zmiany mogą wpłynąć na bezpieczeństwo.

TR Uyarılar

Çocukların ürünü monte etmesine izin verilmez. Montaj sırasında, tüm küçük parçaları çocukların erişemeyeceği bir yerde tutun; yutulması veya solunması halinde ölümcül olabilirler.

Çocukların ürüne tırmanması veya üzerine oynaması yasaktır; devrilme sonucu ciddi belensedel yaralanmaları önlemek için.

Metal taban plakası parçaları mutlaka monte edilmesi gereken zorunlu parçalardır. Bu parçalar takılmadan ürün kullanılmamalıdır.

Devrilmeyi önlemek için bu ürün, verilen duvar bağlantı aparatı ile kullanılmalıdır.

Kurulum, üretici talimatlarına tam olarak uygun şekilde yapılmalıdır; aksi takdirde yanlış montaj durumunda güvenlik riski oluşabilir.

Kutu açıldıktan sonra herhangi bir parça eksik veya kusurluysa, montaja hemen ara verin ve bizimle iletişime geçin. Yetkisiz değişiklikler güvenliği etkileyebilir.

JP 安全警告メッセージ

ボルトなどの小部品は、お子様が誤って飲み込む事により、窒息などの重大事故を引き起こす恐れがありますので、お子様がいない場所で組立を行ってください。

転倒による重傷を避けるため、製品に登ったり遊んだりすることは禁止されています。

底部の金属製プレートは必須部品です。必ず取り付けてご使用ください。本製品は、底部の金属製プレート部品を装着しない状態でのご使用は禁止いたします。

安全のため、転倒防止の安全紐を壁面に固定することをおすすめします。本品の転倒により、ケガや致命傷になる恐れがありますので、必ずご注意ください。

ご使用前に本書をよくお読みになり、内容を理解された上で、ご使用くださいますようお願い致します。

開封時に部品の欠品・不良があった場合は、直ちに組立を中止し当社までご連絡ください。無断改造は安全性低下の原因となります。

販売元：ZIELJP株式会社 〒531-0062 大阪市北区長柄中3丁目6番13号

TEL:06-7161-1020 メール:info_jp@songmics.jp

AR

تحذيرات

يُمنع الأطفال من تجميع المنتج. أثناء التجميع، يُرجى إبقاء جميع الأجزاء الصغيرة بعيدًا عن متناول الأطفال، فقد تكون مميتة إذا تم ابتلاعها أو استنشاقها.

يُحظر على الأطفال تسلق المنتج أو اللعب به، لتجنب الإصابة الجسدية الخطيرة الناتجة عن انقلابه.

ألواح الأرجل المعدنية مكوّنات أساسية ويجب تركيبها. يُمنع استخدام المنتج دون تركيبها.

لتفادي انقلاب المنتج، يجب استخدام جهاز التثبيت الجداري المرفق.

يجب تنفيذ التركيب بدقة تامة وفقًا لتعليمات الشركة المصنّعة، حيث إن أي خطأ في التركيب قد يؤدي إلى

مخاطر تتعلق بالسلامة.

إذا وُجدت أي أجزاء تالفة أو مفقودة بعد فتح العبوة، توقف عن التجميع فورًا واتصل بنا. قد تؤثر التعديلات أو

التغييرات غير المصرح بها على السلامة.

PT Avisos de Segurança

Crianças não devem montar este produto. Durante a montagem, mantenha todas as peças pequenas fora do alcance de crianças, pois podem ser fatais se ingeridas ou inaladas.

É proibido que crianças subam ou brinquem sobre o produto, a fim de evitar ferimentos graves causados por tombamento.

As placas de metal para os pés são componentes obrigatórios e devem ser instaladas. Não utilize o produto sem elas.

Para evitar tombamentos, o produto deve ser usado com o dispositivo de fixar na parede fornecido.

A instalação deve ser realizada estritamente conforme as instruções do fabricante, pois a montagem incorreta pode representar risco à segurança.

Caso identifique peças defeituosas ou ausentes após abrir a embalagem, interrompa a montagem imediatamente e entre em contato conosco. Modificações ou alterações não autorizadas podem comprometer a segurança do produto.

KR 경고사항

어린이는 제품을 조립할 수 없습니다. 조립 중에는 모든 작은 부품들을 어린이의 손이 닿지 않는 곳에 보관하십시오. 삼키거나 흡입할 경우 치명적일 수 있습니다.

어린이가 제품에 오르거나 놀지 못하도록 하십시오. 제품이 넘어질 경우 심각한 신체 상해를 입을 수 있습니다.

금속 발판은 필수 구성품이며 반드시 설치해야 합니다. 발판 없이 제품을 사용하지 마십시오.

제품이 넘어지는 것을 방지하기 위해 제공된 벽 고정 장치와 함께 사용해야 합니다.

설치는 제조업체의 지침에 따라 정확하게 수행되어야 합니다. 그렇지 않으면 잘못 설치될 경우 안전 위험이 발생할 수 있습니다.

개봉 후 결함이 있거나 누락된 부품이 있는 경우 즉시 조립을 중단하고 당사에 연락하십시오. 무단 변경 및 수정은 안전에 영향을 미칠 수 있습니다.

CS Varování

Dětem není dovoleno výrobek sestavovat. Při montáži mějte všechny malé součástky mimo dosah dětí, protože by mohly být nebezpečné při polknutí nebo vdechnutí.

Dětem je zakázáno ležet nebo si na výrobku hrát, aby se zabránilo vážnému poranění způsobenému převrácením.

Kovové podnožky jsou povinnou součástí a musí být nainstalovány. Nepoužívejte produkt bez nich.

Pro zabránění převrácení musí být tento výrobek použit s příloženým upevňovacím prvkem na stěnu.

Montáž musí být provedena přesně podle pokynů výrobce, jinak může při nesprávné instalaci dojít k bezpečnostnímu riziku.

Pokud po vybalení zjistíte chybějící nebo poškozené díly, okamžitě přestaňte s montáží a kontaktujte nás. Nepovolené úpravy a změny mohou ovlivnit bezpečnost.