

# ASSEMBLY INSTRUCTION

DESCRIPTION: CAL.KING/EASTERN KING HEADBOARD

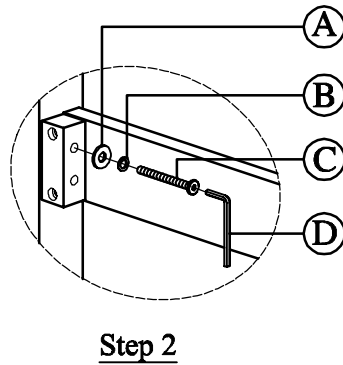
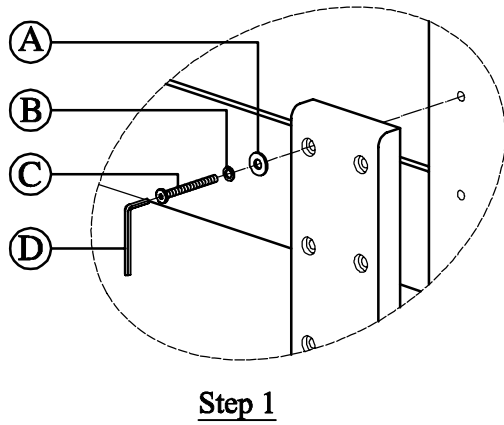
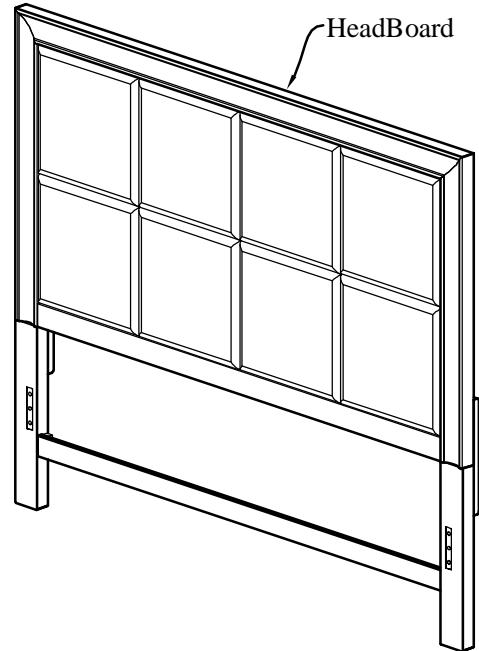
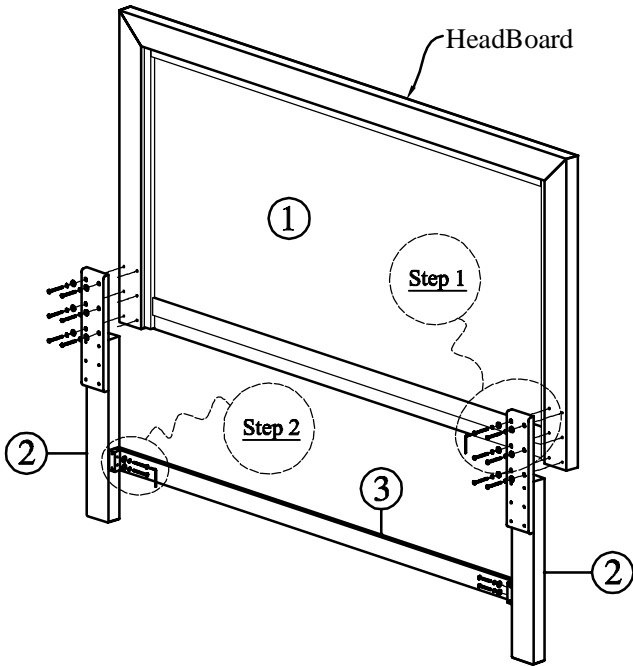

Step 1

Step 2

## PART LIST

No.	Part description	Q'ty
1	Headboard	1
2	Headboard Leg (1R & 1L)	2
3	King Headboard Bottom Rail	1

## HARDWARE LIST

No.	Hardware Description	Q'ty
A	Flat washer (Ø1/4" x 1/2")	16
B	Lock Washer (Ø1/4")	16
C	Bolt (Ø1/4" x 1 3/4")	16
D	Allen key (4 x 59mm)	1
Above Hardware Packed with HeadBoard		

# ASSEMBLY INSTRUCTION

DESCRIPTION: CAL.KING/EASTERN KING STORAGE FOOTBOARD

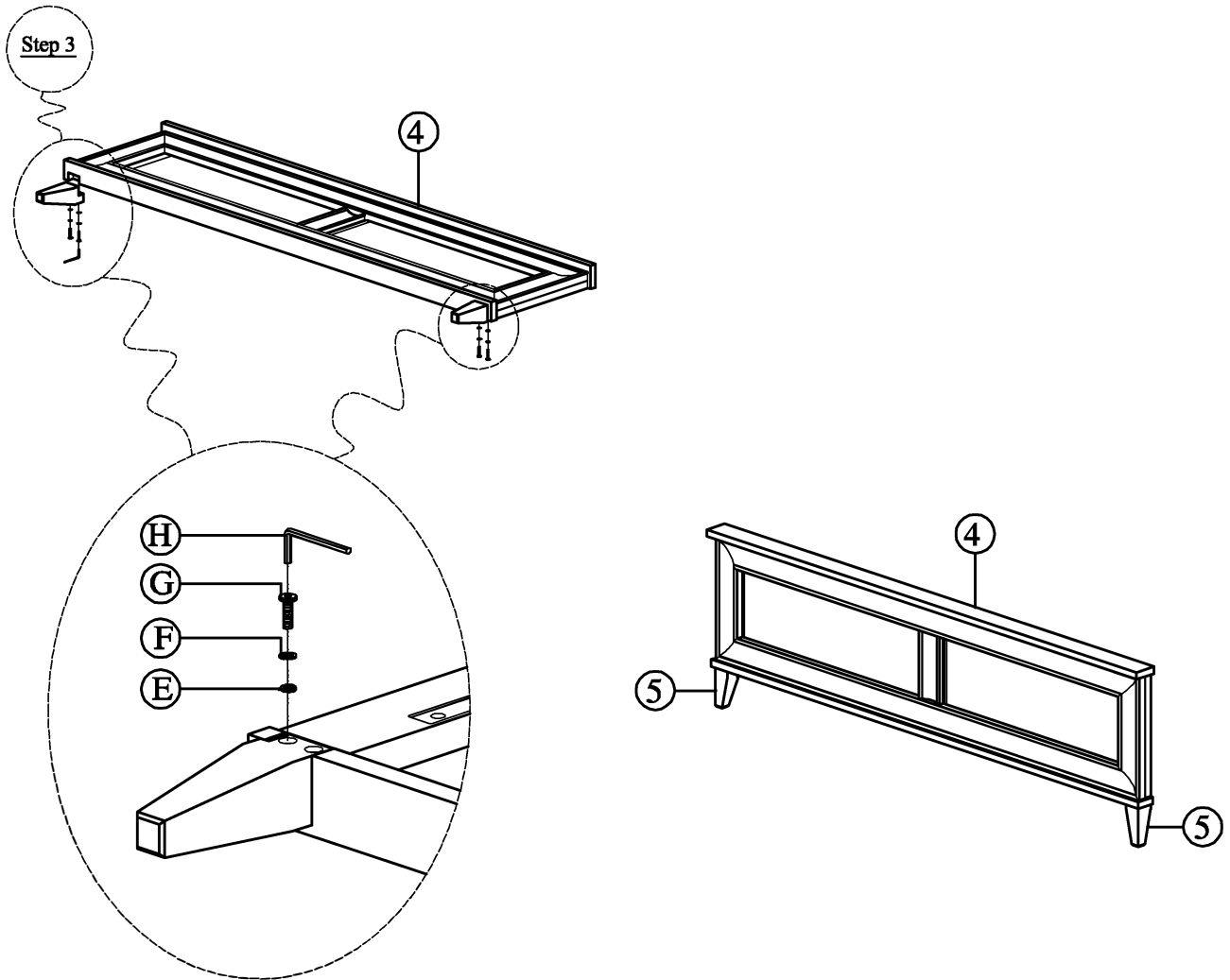

Step 3

PART LIST		
No.	Part description	Q'ty
4	King Storage Footboard	1
5	Footboard Leg ( 1R & 1L)	2

HARDWARE LIST		
No.	Hardware Description	Q'ty
E	Flat washer (Ø1/4" x 1/2")	4
F	Lock Washer (Ø1/4")	4
G	Bolt (Ø1/4" x 2")	4
H	Allen key (4 x 59mm)	1
Above Hardware Packed with Footboard		

# ASSEMBLY INSTRUCTION

DESCRIPTION: CAL.KING/EASTERN KING STORAGE FOOTBOARD

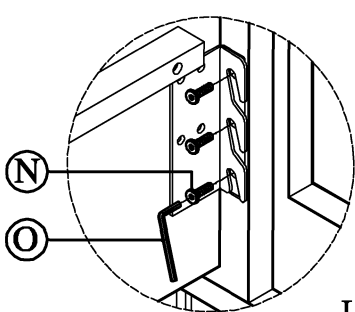

Step 4

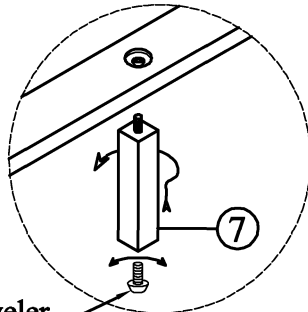

Leveler

Step 5

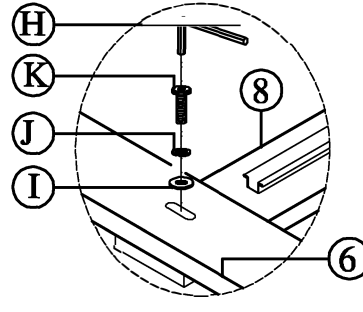

Step 6

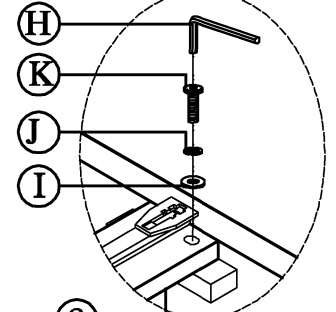

Step 7

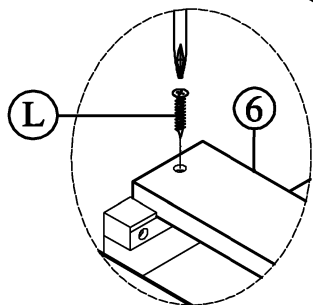
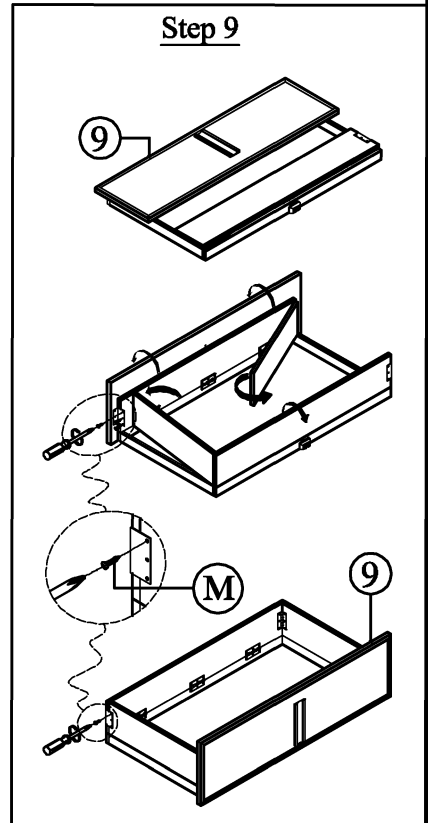
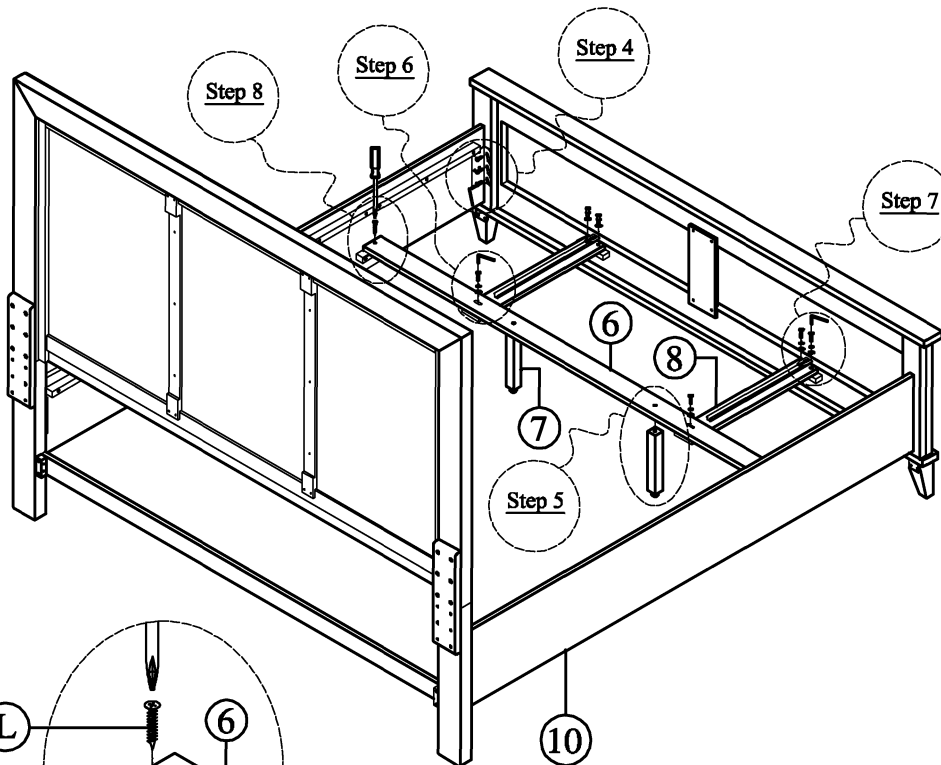

Step 8

## PART LIST

No.	Part description	Q'ty
6	King Bed Footboard Storage Drawer Slat	1
7	Storage Drawer Support leg With Leveler	2
8	Footboard Storage Rail With Drawer Slide	2
9	King Bed Storage Drawer	2

## HARDWARE LIST

No.	Hardware Description	Q'ty
I	Flat washer (Ø1/4" x 3/4")	6
J	Lock Washer (Ø1/4")	6
K	Bolt (Ø1/4" x 1 3/8")	6
L	Screw (Ø4 x 1 1/8")	28
M	Screw (Ø3.5 x 3/8")	12

Above Hardware Packed with Footboard

# ASSEMBLY INSTRUCTION

DESCRIPTION: CAL.KING STORAGE SIDE RAILS WITH CAPS

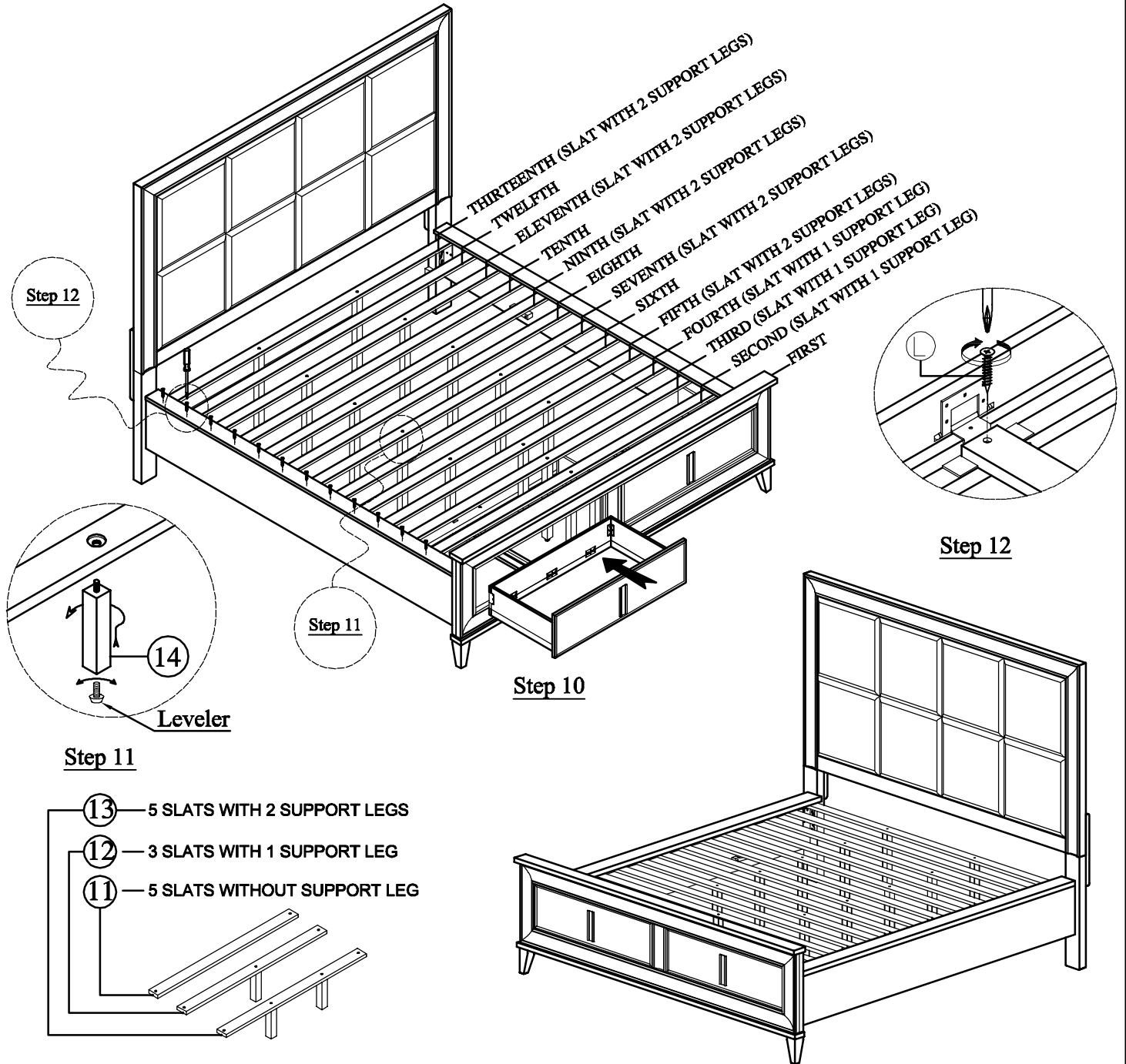

## PART LIST

No.	Part description	Q'ty
10	Storage Bed Side Rail	2
11	King Bed Slats (Without Support Leg)	5
12	King Bed Slats (With 1 Support Leg)	3
13	King Bed Slats (With 2 Support Leg)	5
14	Slat Support Leg With Leveler	13

## HARDWARE LIST

No.	Hardware Description	Q'ty
N	Bolt (Ø5/16" x 1")	12
O	Allen key (4 x 59mm)	1

Above Hardware Packed with Side Rail