

HausPRO

Dual Fuel Range

PRD Model User Manual

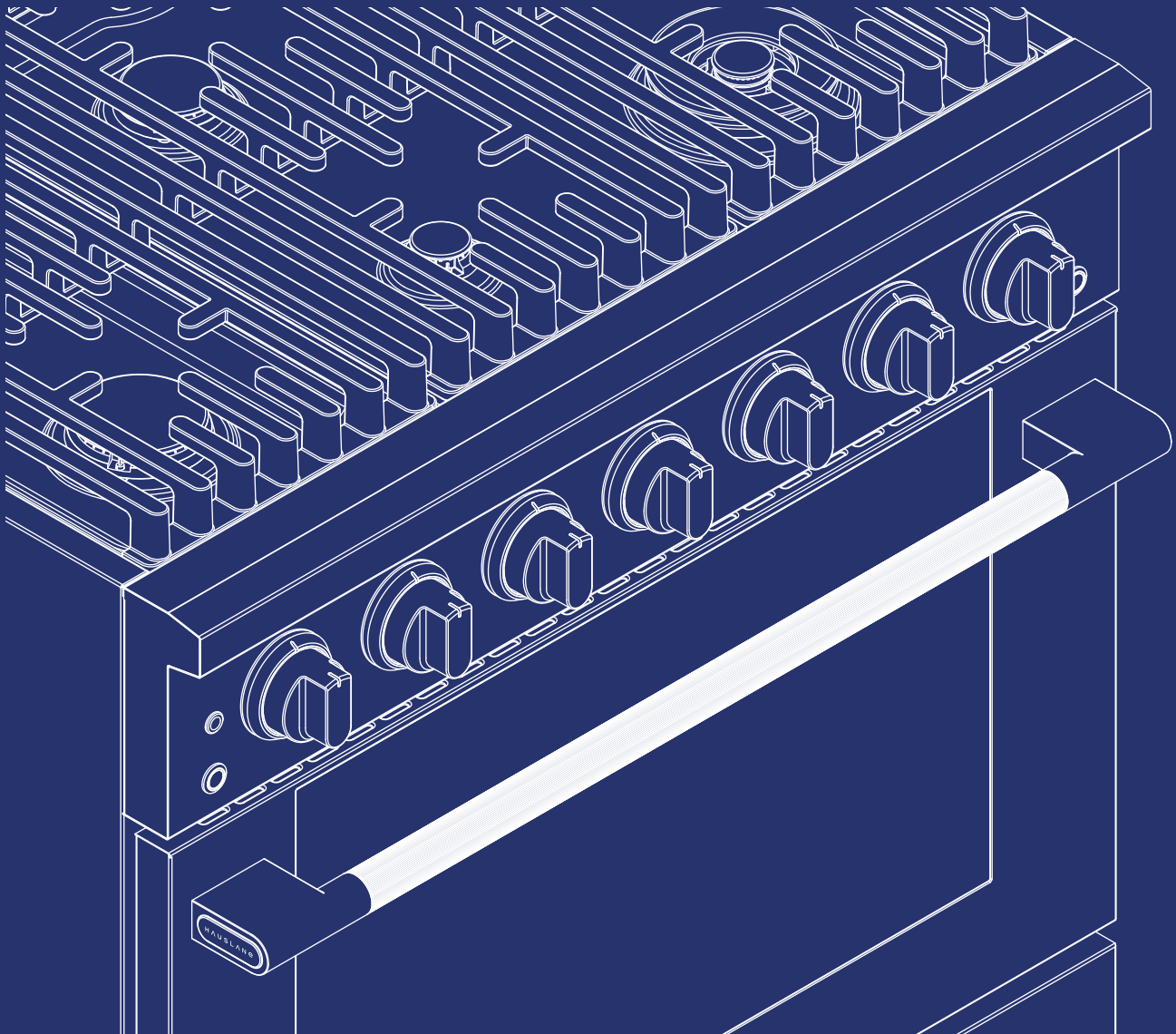

HAUSLANE

Table of Contents

Safety Information	1	Ensure There Is Proper Height Clearance	13
Gas Safety	1	Check Your Gas Supply and Electrical Connection	13
Electric and Gas Safety	2	Pre-Installation Specifications and Instructions	14
Installation Safety	3	Find a Helper	14
Cooktop Safety	3	How to Install Your Range	16
Ventilation Safety	4	Test the Unit	16
Storage and Fire Safety	4	Installing Parts	16
Surface Burner Safety	5	Gas Connection Requirement	17
Cooking Safety	5	Liquid Propane Gas Conversion Procedure (Optional).....	19
Tipping Safety	6	Installing the Anti-Tip Bracket	24
Warranty Information	7	How to Use Your Range	25
Specifications	9	Cooktop Safety	25
Package Contents	10	Guidelines for Using Surface Burners.....	25
Tools Needed	11	Manual Flame Adjustment	25
What's Included	11	Surface Burner Operation.....	25
Control Panel	12	Oven Operation.....	27
Preparation: What to Do Before Installation	13	Basic Maintenance Instructions	29
Read This Manual.....	13	Removing the Oven Door and Kick Plate.....	29
Gather Your Tools.....	13	Replacing the Oven Lights	30
Inspect the Unit.....	13	Cleaning Your Range.....	30
Range Placement.....	13	Troubleshooting Tips	32
		Contact Hauslane	34

Safety Information

Before installing your range, read the entire instruction manual. Installers, leave this manual with the homeowner.

⚠ WARNING: Suitable for use in household cooking area ONLY. To reduce the risk of fire, electrical shock, or injury, observe the following:

1. Use this range ONLY in the manner intended by the manufacturer. If you have the questions, contact Hauslane at **1-800-929-0168** or email at **info@hauslane.com**.
2. Before servicing or cleaning, switch power off at service panel and lock service panel to prevent power from being switched on accidentally. When the service disconnecting means cannot be locked, securely fasten a prominent warning device, such as a tag, to the service panel.
3. Installation work and electrical wiring MUST BE done by qualified personnel in accordance with all applicable codes and standards, including fire-rated construction codes and standards.
4. This unit MUST BE grounded.

GAS SAFETY WARNING

⚠ WARNING: Failure to follow these instructions exactly may result in a fire or explosion, leading to property damage, serious injury, or even death.

1. NEVER store or use gasoline or other flammable liquids near this appliance — or any other appliance.
2. If You Smell Gas:
 - DO NOT try to light the appliance.

- DO NOT touch any electrical switches.
- DO NOT use any phone inside your home.
- Go to a neighbor's house and call your gas supplier right away. Follow their instructions carefully.
- If you can't reach your gas supplier, call the fire department.

⚠ IMPORTANT: Installation and service MUST BE done by a qualified professional — either a licensed installer, a service technician, or your gas provider.

TO REDUCE THE RISK OF A RANGE TOP GREASE FIRE:

1. NEVER leave surface units unattended at high settings. Boil overs cause smoking and greasy spillovers that may ignite. Heat oils slowly on low or medium settings.
2. ALWAYS turn hood ON when cooking at high heat or when cooking flaming foods.
3. Clean ventilating fans frequently. Grease should not be allowed to accumulate on fan or filter.
4. Use proper pan size. ALWAYS use cookware appropriate for the size of the surface elem **TO REDUCE THE RISK OF INJURY TO PERSONS IN THE EVENT OF A RANGE TOP GREASE FIRE, OBSERVE THE FOLLOWING:**

- SMOTHER FLAMES with a close-fitting lid, cookie sheet or metal tray, then turn off the burner. BE CAREFUL TO PREVENT BURNS. IF THE FLAMES DO NOT GO OUT IMMEDIATELY, EVACUATE AND CALL THE FIRE DEPARTMENT.
- NEVER Pick up a flaming pan as you may be burned.

HAUSLANE

- DO NOT USE WATER, including wet dishcloths or towels. This could cause a violent steam explosion.
- Use an extinguisher ONLY if:
 - A. You own a Class ABC extinguisher and you know how to operate it.
 - B. The fire is small and contained.
 - C. The fire department has been called.
 - D. You can fight the fire with your back to an exit.

*Based on "Kitchen Fire Safety Tips" published by NFPA.

⚠ WARNING: This appliance is not a space heater. NEVER use it to heat or warm a room — doing so can lead to carbon monoxide poisoning and overheating. DO NOT use the stovetop or oven as storage. Items left inside or on top of the range can melt, catch fire, or cause serious injury.

⚠ WARNING: NEVER block oven vents or cover racks with foil. DO NOT cover any openings or slots inside the oven, and never line an entire oven rack with aluminum foil. Doing so restricts airflow, which can lead to carbon monoxide poisoning or fire from trapped heat.

- Block proper ventilation
- Cause carbon monoxide buildup
- Trap heat and start a fire

IMPORTANT SAFETY INFORMATION

Before you start installing your range, please read and follow these important safety instructions:

The manufacturer will not be responsible for any damage to property or to persons caused by incorrect installation, improper use of the appliance, or failure to heed the warnings listed.

The manufacturer is not responsible for any damage or injury caused by improper installation, incorrect use, or ignoring safety warnings.

The appliance is designed for non-commercial, residential use ONLY.

We may update or improve the product over time, but these changes will NEVER compromise safety or core functionality.

ALWAYS follow local, state, and national codes and ordinances. Ensure the range is properly grounded and the plug is accessible after installation.

This manual doesn't cover every possible situation you might encounter. If anything is unclear, contact a qualified service technician or the manufacturer directly.

The installer should leave these instructions with you. Keep them for future reference and inspections.

⚠ WARNING: Installation and servicing MUST be done by a qualified installer, service agency, or your gas supplier.

For mobile homes, the appliance MUST BE installed according to Title 24CFR, Part 3280 (Manufactured Home Construction and Safety Standard) or local codes where applicable. Any gas-fired appliance should be installed by a licensed plumber or gas fitter.

A manual shut-off valve must be added to the gas line for both safety and convenience.

If your home is at a higher altitude, gas pressure may be affected — which can impact how the appliance performs.

Check with your local gas provider before purchase or installation to make sure it's a good fit for your location.

IMPORTANT SAFETY ALERTS

⚠ DANGER: When you see this symbol, it means a serious hazard is present. Ignoring it could lead to death or serious injury.

⚠ WARNING: This symbol indicates a situation that could cause moderate or minor injury if not handled properly.

Use Care When Unpacking:

- Remove all tape, zip ties, and packaging before using the appliance.
- Safely discard all packing materials — boxes, bags, and plastic wrap — after unpacking.
- NEVER let children play with packaging. Boxes covered in fabric or plastic can become air-tight and dangerous.
- Remove all staples from the box to avoid cuts or damage to nearby surfaces.
- DO NOT remove the model or serial number plate from the appliance. This is needed for warranty and service support.

ELECTRIC AND GAS SAFETY

Make sure your appliance is installed and grounded by a qualified technician, following all local codes and national standards (ANSI Z223.1 / NFPA 70 in the U.S., or CAN/CGA B149.1/.2 and CSA standards in Canada).

Be aware that not all gas leaks can be detected by smell. It's strongly recommended to use a UL- or CSA-approved gas detector. Contact your gas supplier for recommendations.

If You Detect a Gas Leak Refer to the "If You Smell Gas" instructions on **page 1** immediately.

Installation and servicing MUST ONLY be performed by a qualified installer, technician, or gas supplier. Ask the manufacturer to recommend authorized professionals in your area.

In an emergency, know how to shut off the gas at the meter and cut power at the breaker or fuse box. The installer should also show you where the appliance's gas shut-off valve is located and how to use it.

DO NOT attempt repairs yourself unless they are clearly outlined in this manual. All other servicing should be done by a qualified professional to avoid injury or equipment damage.

⚠ DANGER: ALWAYS disconnect both gas and power before performing service — especially when working on critical systems. Failing to do so increases the risk of fire, explosion, injury, or death.

INSTALLATION SAFETY

NEVER modify or remove any panels, wire covers, or built-in components of the appliance.

DO NOT step on, lean on, or sit on the appliance doors — it can cause damage or injury.

If the appliance is near a window, DO NOT hang long curtains or paper blinds nearby. They can blow onto the burners and ignite.

Ensure the room has good ventilation. Keep air intakes open and working properly. A Hauslane range hood is strongly recommended — it should be installed 30" to 36" (762 mm to 914 mm) above the cooktop to support airflow and remove fumes. Do not exceed the maximum height of 36" (914 mm) while in operation.

⚠ WARNING: DO NOT install or use a ventilation system that blows air downward onto the cooktop (such as an air curtain hood). This can interfere with proper burner performance and create a safety hazard.

1. VENTILATION DURING HEAVY USE

If you're cooking for an extended period of time, make sure your kitchen is well-ventilated. Open a window or increase the power of your range hood to help clear out heat, smoke, and gas byproducts.

2. KEEP FLAMMABLE MATERIALS AWAY

NEVER store flammable items — like paper, plastic, cloth, towels, cookbooks, or plasticware — on or near the stovetop or oven.

DO NOT store aerosol cans, gasoline, or other flammable liquids anywhere near the appliance. These can explode or catch fire, leading to serious damage or injury.

3. KEEP THE AREA AROUND THE APPLIANCE CLEAR

Make sure there's nothing combustible around the range — including cleaning supplies, rags, and any other flammable materials.

4. DON'T STORE ANYTHING INSIDE THE OVEN

The oven should never be used for storage, especially for flammable items. Always check inside before turning it on.

⚠ FOR MASSACHUSETTS RESIDENTS ONLY

The following installation instructions apply in the State of Massachusetts:

- All installations and repairs must be performed by a licensed contractor, plumber, or gas fitter authorized by the State of Massachusetts.
- If using a ball valve, it must be the T-handle type.
- Any flexible gas connector used must be no longer than 3 feet (914 mm).



CALIFORNIA RESIDENTS ONLY WARNING:

Cancer and Reproductive Harm
www.P65Warnings.ca.gov

CALIFORNIA PROPOSITION 65 WARNING

Under California law, businesses MUST warn customers about exposure to chemicals known to cause cancer, birth defects, or other reproductive harm.

Gas appliances may expose users to small amounts of the following substances:

- Benzene
- Carbon monoxide
- Formaldehyde
- Soot

These substances are mainly the result of incomplete combustion of natural gas or propane. To reduce exposure:

- Ensure burners are properly adjusted — a blue flame (not yellow) means they're burning efficiently.
- ALWAYS cook in a well-ventilated space. Open a window, or use your ventilation fan or range hood during use.

COOKTOP SAFETY

⚠ DANGER:

KEEP CHILDREN SAFE AROUND THE COOKTOP:

DO NOT store anything attractive to children — like snacks, toys, or cookware — in cabinets above the appliance or on the backsplash.

NEVER leave children unattended near the range. DO NOT allow them to climb, sit, or play on or around it — serious burns or injuries can result.

HOT SURFACES CAN CAUSE BURNS:

DO NOT touch the burners, grates, cooktop, or any nearby surfaces while the appliance is in use or shortly after. Even if you don't see flames, surfaces can still be dangerously hot.

Be careful with clothing and flammable items:

Avoid wearing loose or hanging clothing while cooking. Keep all fabrics, oven mitts, and other flammable materials away from hot surfaces.

If a grease fire starts, DO NOT use water:

Smother small grease fires with a pan lid, baking soda, or a dry chemical or foam extinguisher.

ONLY USE A FIRE EXTINGUISHER IF:

- You have a Class A, B, or C extinguisher and know how to use it
- The fire is small and contained
- The fire department has been called or is on the way
- You can fight the fire with your back to an exit

WATCH GREASE CAREFULLY

Grease or oil can ignite if it gets too hot. Stay in the kitchen when heating fat or frying.

USE POTHOLDERS SAFELY

ONLY use dry potholders or oven mitts. Moist ones can cause steam burns. NEVER let potholders come in contact with burners, flames, or heating elements. DO NOT use towels or bulky cloths instead.

DON'T HEAT SEALED CONTAINERS

Unopened cans or jars can explode when heated, causing injury.

HAUSLANE

NEVER STEP OR SIT ON THE APPLIANCE

This can result in serious injury and may damage the range.

KNOW YOUR CONTROLS

Make sure you know which knob controls each burner. After lighting, always visually confirm the flame is on, and adjust it so it stays within the edge of your cookware.

CLEAN REGULARLY TO PREVENT GREASE FIRES

Keep the cooktop and hood filters clean. Grease buildup can ignite.

When cooking, always turn on the range hood fan. Follow the hood manufacturer's instructions for cleaning and operation.

TURN POT AND PAN HANDLES INWARD

To prevent burns, fires, or spills, always turn pot and pan handles inward so they don't extend over nearby burners. This helps avoid accidental contact and tipping.

DON'T LINE YOUR APPLIANCE WITH FOIL

NEVER use aluminum foil to line the oven, cooktop, or any part of the range. Foil should only be used to cover food during cooking. Misusing foil may lead to electric shock or fire, and could void your warranty.

USE COOKWARE THAT'S MADE FOR STOVETOP USE

ONLY use cookware that's rated safe for temperature changes — like glass, ceramic, or earthenware approved by the manufacturer. Sudden heat shifts can cause certain materials to crack or break.

⚠️ WARNING: NEVER leave burners unattended: A pot boiling over or a dry pan left on the burner can create smoke, greasy flames, or even melt the cookware.

AVOID DECORATIVE BURNER COVERS

DO NOT use burner covers. If a burner is accidentally turned on, the cover can melt, and you may not even realize it's hot. This poses a burn risk and can damage the appliance.

MATCH FLAME SIZE TO YOUR COOKWARE

ALWAYS adjust the flame so it stays under your pot or pan. Flames that extend beyond cookware edges waste energy and increase the risk of igniting clothing or nearby items.

USE COOKWARE THAT FITS YOUR BURNERS

Choose pots and pans with flat bottoms that match the size of the burner. Undersized cookware can expose part of the flame and reduce efficiency.

GRIDDLE SAFETY FOR PRD48 RANGE

This model includes a reversible cast iron griddle that can be placed front-to-back over any of the four grates. Make sure the griddle is completely cool before handling it, and use caution when placing or flipping it to avoid damaging the range or grates. A griddle is also available for purchase (GRD-01) for PRD30 and PRD36 models.

DO NOT USE STOVETOP GRILLS

NEVER use add-on stovetop grills with sealed gas burners. Doing so can cause incomplete combustion and dangerous carbon monoxide exposure, which is a serious health risk.

VENTILATION SAFETY

PROPER VENTILATION IS ESSENTIAL

DO NOT block airflow. Your appliance needs steady ventilation to operate safely and maintain the right temperature in your kitchen.

FOLLOW LOCAL BUILDING CODES

Installation MUST follow all national and local codes and ordinances. Requirements may vary depending on your area, so check before beginning.

ALLOW ROOM FOR AIR INTAKE

For gas appliances to work properly, fresh air must flow into the room — ideally through openings in the outside walls.

These vents should NEVER be near the floor and should remain clear and unobstructed from both inside and outside. It's best to place them on the opposite wall from the flue outlet.

INSTALL THE APPLIANCE SAFELY

Avoid putting cabinets directly over the cooking area. This minimizes the risk of burns from reaching over hot surfaces.

If overhead cabinets are necessary:

- Keep them no deeper than 13" (330 mm)
- Use a range hood that extends at least 5" (127 mm) past the cabinet bottom
- Maintain a 30" (762 mm) minimum clearance between the cooktop and the bottom of the hood

CHECK SURROUNDING MATERIALS

Ensure walls, cabinets, and countertops near the range can handle heat up to 200°F (93°C). Consult a qualified installer or technician to verify.

STORAGE AND FIRE SAFETY

KEEP ITEMS OUT OF REACH OF CHILDREN

DO NOT store anything that might attract children in cabinets above the range or on the steel backsplash vent. Kids climbing to reach these items could get seriously hurt.

NEVER LEAVE CHILDREN UNATTENDED

Even if the burners and oven have been turned off for several minutes, the range's door, knobs, and cooktop may still be hot enough to cause serious burns.

NO CLIMBING OR HANGING

DO NOT allow anyone to climb, stand, or hang on the range. This can damage the appliance or cause it to tip over, leading to serious injury.

⚠️ DANGER: NEVER use this appliance to heat or warm a room. Doing so risks carbon monoxide poisoning and overheating.

Avoid wearing loose or hanging clothing while using the range, and be cautious when reaching for items in cabinets above the appliance. Flammable materials can catch fire if they touch flames or hot surfaces.

DO NOT place flammable materials inside the oven or near the range.

Keep combustible liquids like gasoline and other flammable vapors well away from the appliance.

DO NOT store cooking grease or other flammable materials on or near the range.

NEVER leave burners unattended on high heat. Boilovers can create smoke and grease spills that may catch fire, and pans left dry on high heat can melt.

Do NOT use water to extinguish grease or oil fires.

IF A GREASE FIRE HAPPENS:

1. DO NOT touch the pan.
2. Turn off the burner controls immediately.
3. Smother the fire by covering the pan completely with a tight-fitting lid, cookie sheet, or flat tray.
4. Alternatively, sprinkle baking soda on the fire or use a multi-purpose dry chemical or foam fire extinguisher if available.

For flames inside the oven, close the oven door, turn controls off, or use a fire extinguisher to put out the fire.

ALWAYS wait for burner grates and surfaces to cool completely before touching them.

NEVER block the appliance vents. These air holes are essential for proper air flow and safe, efficient combustion.

Gas leak testing must always follow the manufacturer's instructions. ALWAYS have a qualified technician perform this test.

Ensure proper installation and grounding by a qualified installer according to the Installation Manual. Any repairs or adjustments should only be done by certified gas range technicians.

Place the appliance away from kitchen traffic and drafts to maintain good air circulation and safe operation.

⚠ DANGER: DO NOT step on, lean, or sit on the range.

This can cause injury or damage to the appliance. Keep children from climbing or playing around the range, as it may tip and cause serious burns or injuries.

ONLY perform repairs or part replacements specifically instructed in this manual. All other service should be handled by qualified technicians.

Remove all packaging materials, including plastic zip ties securing oven racks, before use. Failure to do so can cause fire or smoke damage.

When cooking, adjust burner flames so they heat only the bottom of pots or pans without extending beyond the edges.

For cookware that heats slowly (like glass pots), use low to medium flame settings.

Use the appliance solely for cooking as described in this manual.

DO NOT touch grates, burner caps, burner bases, or any parts near the flame during or shortly after use—they can cause burns.

Avoid touching the oven's interior surfaces until fully cooled.

DO NOT line any part of the appliance with aluminum foil. Use foil only to cover food during cooking. Improper foil use can cause electric shock, fire, and may void the warranty.

SURFACE BURNER SAFETY

⚠ WARNING: If a burner flame goes out, gas will keep flowing until you turn the knob off. ALWAYS turn knobs to OFF immediately if the flame extinguishes.

NEVER leave surface burners unattended, especially when on high heat.

Use ONLY stable cookware with flat bottoms that fully cover the burner grates. This prevents spills and reduces fire risk.

Turn pot and pan handles inward, away from adjacent burners, to avoid burns, fires, or spills.

ALWAYS turn burner knobs to HI to ignite burners, then adjust the flame size once lit.

Use ONLY dry pot holders or oven mitts. Wet holders can cause burns from steam. Keep holders away from open flames. NEVER substitute towels or bulky cloths for pot holders.

DO NOT use decorative burner covers. If a burner turns on accidentally with a cover, it may overheat and melt, causing burns and damage.

Avoid using stove top grills or griddles on sealed gas burners. They can cause incomplete combustion and unsafe carbon monoxide levels.

ONLY use glass or ceramic cookware made specifically for stovetop use to prevent cracking or breaking.

⚠ WARNING: NEVER place any items on the cooktop or backsplash. Hot air vents can ignite flammable objects and cause sealed containers to burst, posing a serious injury risk.

COOKING SAFETY

Before using your new range for the first time, we recommend heating the oven to 400 °F (200 °C) for 1 hour, then switching to the broil setting for another hour. For the PRD48 model, do this for both the large and small ovens. You may notice some smoke or odors during this process. This is normal, as manufacturing oils are burning off. Make sure the room is well ventilated by keeping air intakes open or by using a range hood.

After the oven cools, clean it with hot water and a kitchen-safe cleaner. It's also a good idea to clean the oven racks and shelves before use.

When frying, watch foods carefully and heat fats slowly. Stir combinations of oils and fats before heating, and use a deep-fry thermometer if possible to avoid overheating beyond the smoke point.

Use ONLY the minimum amount of fat necessary for frying. Overfilling pans can cause dangerous spillovers when food is added.

NEVER cook food directly on the flame. Always use appropriate pots or pans.

DO NOT use a wok with a round metal ring that sits on the burner grate to support it. This ring traps heat, which can damage the burner and cause unsafe carbon monoxide levels.

Foods for frying should be as dry as possible. Moisture or frost can cause hot fat to bubble and spill over.

NEVER try to move a pan of hot fat or oil. Wait until it has fully cooled.

DO NOT place plastic items on or near the cooktop; they may melt from heat.

HAUSLANE

Keep all plastic materials away from the burners.

To avoid burns, always ensure burner knobs are turned off and grates are cool before removing them.

⚠ DANGER: If you smell gas, immediately turn off the gas supply and contact a qualified service technician. NEVER use an open flame to check for gas leaks.

TIPPING SAFETY

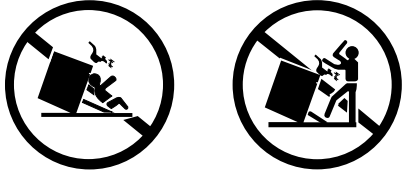

Tipping ranges can cause serious injury or death. To reduce the risk of the range tipping over, it must be secured with a properly installed anti-tip device. Failure to properly install the anti-tip device into the wall could result in death or serious injury to a child or adult.

HOW TO ENSURE PROPER INSTALLATION:

Install the anti-tip device securely to the structure and / or the range.

Verify the anti-tip device is properly installed and engaged by sliding the range back toward the wall where the anti-tip brackets are secured (see “**INSTALLING THE ANTI-TIP BRACKET**” instructions on **page 24** of the installation manual).

Engage the range with the anti-tip device by carefully tilting the front of the range upward slightly and sliding it back so the mounting pins slide under the brackets.

If the range is moved, always re-engage the anti-tip brackets before use.

DO NOT operate the range without the anti-tip device installed and engaged.

⚠ WARNING: Failure to follow these instructions can result in death or serious burns to children or adults.

ALWAYS re-engage the anti-tip device whenever the range is moved by following the steps outlined above and on **page 24** of the installation instructions.

To check the installation, carefully pull the range from the rear. If the anti-tip brackets are installed correctly, the range should not tip more than 4” (102 mm) away from the wall.

If the range tips forward more than 4” (102 mm), the anti-tip device is not installed properly.

⚠ DANGER: DO NOT tip the range more than 4” (102 mm) from the wall, as it could tip over and cause injury.

NEVER completely remove the leveling legs, or the range may not be properly secured to the anti-tip brackets.

NEVER step or sit on the oven door.

Although the range will not tip during normal use, it can tip if too much force or weight is applied to the open oven door without a properly fastened anti-tip brackets.

Warranty Information

COVERAGE

Hauslane dual fuel ranges come with:

A FIVE-YEAR PARTS AND SERVICE WARRANTY

A limited lifetime warranty on burners and spark tips.

The warranty period begins on the original product delivery date and applies ONLY to the original purchaser of a new product delivered in its original packaging. The limited warranty covers all parts to repair defects in materials or workmanship.

Warranty service applies ONLY to products deemed serviceable through troubleshooting with the Hauslane support team.

All warranty service MUST BE authorized and performed by Hauslane-approved, certified service providers unless otherwise specified. Service is available during normal business hours, and the product must be accessible and unobstructed at the time of service.

Hauslane's liability is limited to the original purchase price of the product. Any additional damages, losses, injuries, or inconveniences caused by product defects or malfunctions are not covered under this warranty.

TERMS

This warranty applies ONLY to products installed for normal residential use, defined as a single-family residential dwelling in a non-commercial setting.

Warranty claims arising from installation, use, or operation in commercial or non-residential settings are excluded from coverage. Commercial settings include, but are not limited to: schools, churches, hotels, restaurants, vacation rentals (e.g., Airbnb), daycare centers, private clubs, fire stations, common areas in multi-family dwellings, nursing homes, food service establishments, hospitals, and correctional facilities.

This warranty is non-transferable and is valid only from the original product delivery date, regardless of the installation date. It applies ONLY to the original purchaser of a new product installed within the contiguous United States and the District of Columbia.

To maintain coverage, all warranty procedures MUST BE strictly followed. Failure to obtain certified warranty service in accordance with these terms will void the remaining warranty.

Out-of-pocket expenses for repairs will not be reimbursed without prior approval from Hauslane or its authorized service partners. Unauthorized service costs will not be refunded.

If the product qualifies within the warranty period and Hauslane cannot repair the product or a defective part after a reasonable number of attempts, Hauslane may, at its discretion, either replace the defective part or the entire product, or provide a full refund of the original purchase price (excluding installation, removal, or other non-product charges).

When filing a warranty claim, the original purchaser must provide proof of purchase showing the purchase date, along with the product's serial number. The warranty does not apply if the factory serial number is missing, altered, or unreadable.

Hauslane is not responsible for damages resulting from, but not limited to: shipment, delivery, or improper installation; negligence, improper maintenance, misuse, or abuse; unauthorized alteration, modification, or tampering; accidents, fire, floods, pest infestations, pandemics, natural disasters, or other "acts of God"; flare-up fires or damages caused by improper electrical supply, voltage, or power surges; and service required to correct improper installation not in accordance with Hauslane manuals or local codes.

WARRANTY EXCLUSIONS AND IMPORTANT INFORMATION

This warranty does not cover the following:

- Cosmetic damage, scratches, or natural wear from regular use.
- Second-hand items, open-box products, or products purchased from unauthorized sellers.
- Damage caused by incorrect liquid propane gas conversion or related issues.
- Complaints or adjustments related to burner flame behavior.
- Corrections related to normal settings or local gas supply problems such as low pressure.
- Damage caused by any modifications, such as painting parts of the product or cutting the power cord to hardwire the unit.
- Service needed due to gas pressure issues in high-altitude installations. Customers are responsible for providing the correct high-altitude pressure regulator.

If a service visit determines that the issue is not covered under warranty, the customer must pay all associated service fees. Failure to pay will result in cancellation of any remaining warranty coverage.

The information provided in Hauslane installation and user manuals, as well as product listings on the Hauslane website and affiliated platforms, does not cover every potential situation that may arise during installation or use. Hauslane reserves the right to make changes to its products at any time if deemed necessary and safe.

⚠ IMPORTANT: DO NOT install or use any Hauslane product that is missing parts or arrives damaged. If your product arrives with damage, contact Hauslane customer service team at **1-800-929-0168** (8 a.m.–5 p.m., PST, Monday –Friday). or email us at **info@hauslane.com** before installation. Failure to report shipping damage before installation may void your warranty.

Warranty Information

Hauslane is not responsible for damage or injury resulting from improper installation or usage. After the warranty period ends, Hauslane is not obligated to provide repairs, refunds, prorated coverage, discounts, or replacements under any circumstances.

SERIAL NUMBER LOCATION

Please note your appliance's model number (also called the "Model NO.") and serial number for future reference. Both can be found on the rating tag located on the right front edge of your range.

⚠ IMPORTANT: DO NOT remove any permanently affixed labels, warnings, or plates from the product, as doing so will void your warranty.

We recommend attaching your purchase receipt or proof of purchase to this manual for safekeeping.

WARRANTY CLAIM PROCEDURE

If a claimable defect occurs, please contact our customer service team at **1-800-929-0168** (8 a.m.-5 p.m., PST, Monday –Friday). or email us at **info@hauslane.com**.

Before you make your claim call, please ensure that you have:

- Description of the range
- Proof of sale
- Details regarding the defect
- Name(s) and address(es) of the owner and installer

Claims **MUST BE** filled out in writing and returned within six (6) months of the appearance of a defect. Failure to comply with this stipulation will make this warranty null and void. We reserve the right to a thirty-day (30) delay following the receipt of a claim in which to inspect the product. We assume no responsibility for labor costs, removing or replacing a previously installed product, transportation, or the return of a product.

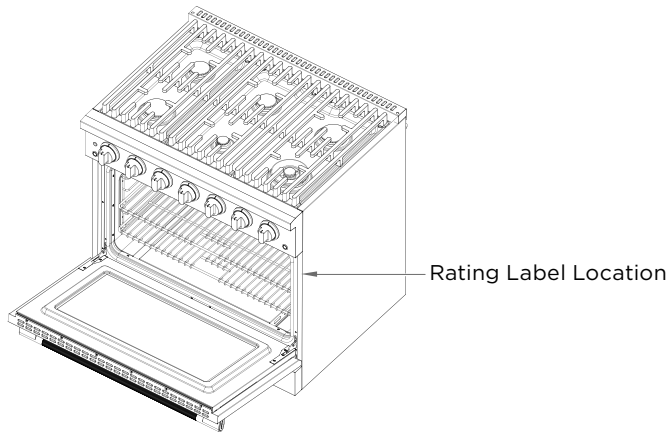
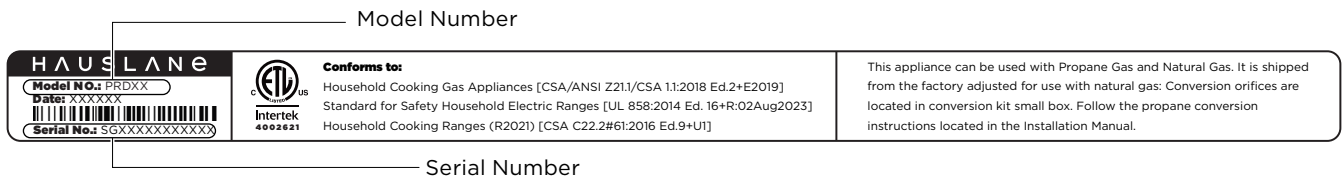

Specifications

PRD30 Model (Front View and Side View Dimensions)

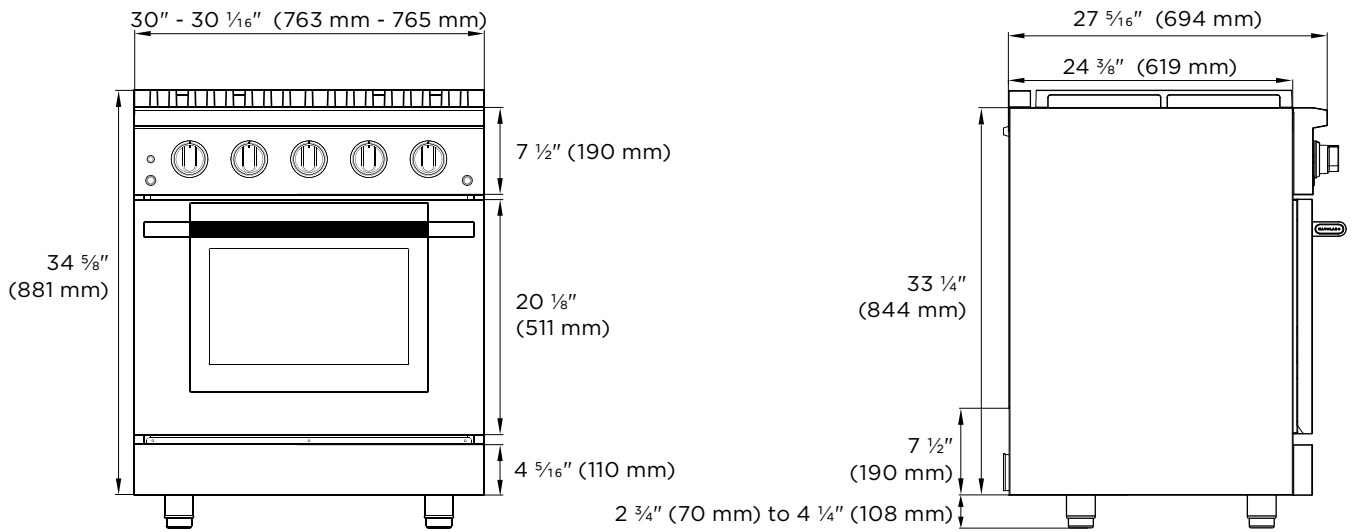

PRD36 Model (Front View and Side View Dimensions)

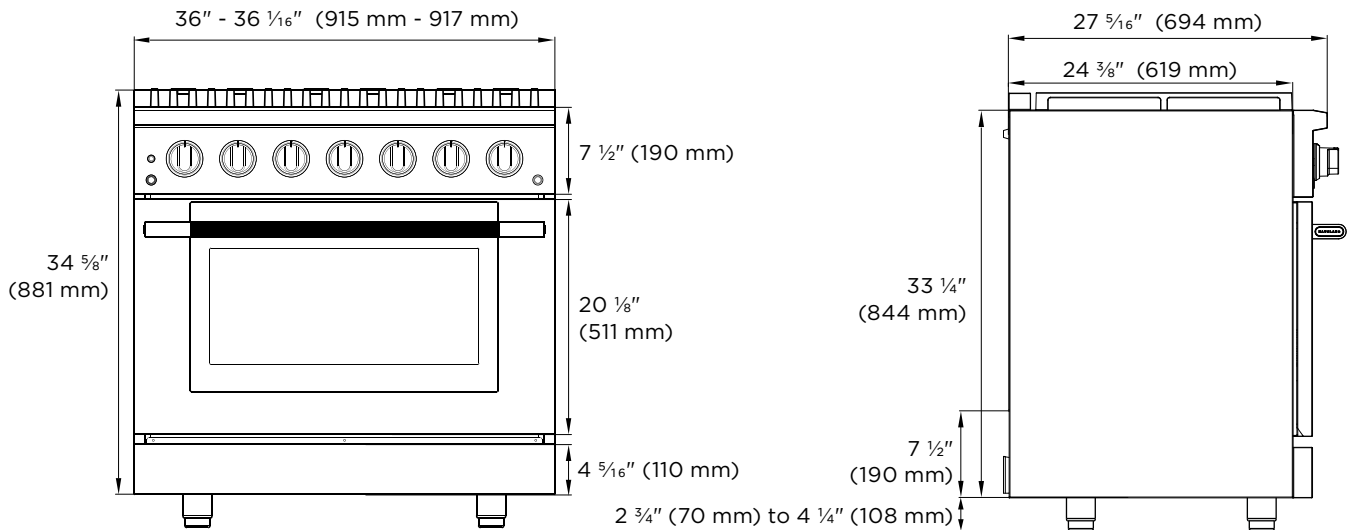

PRD48 Model (Front View and Side View Dimensions)

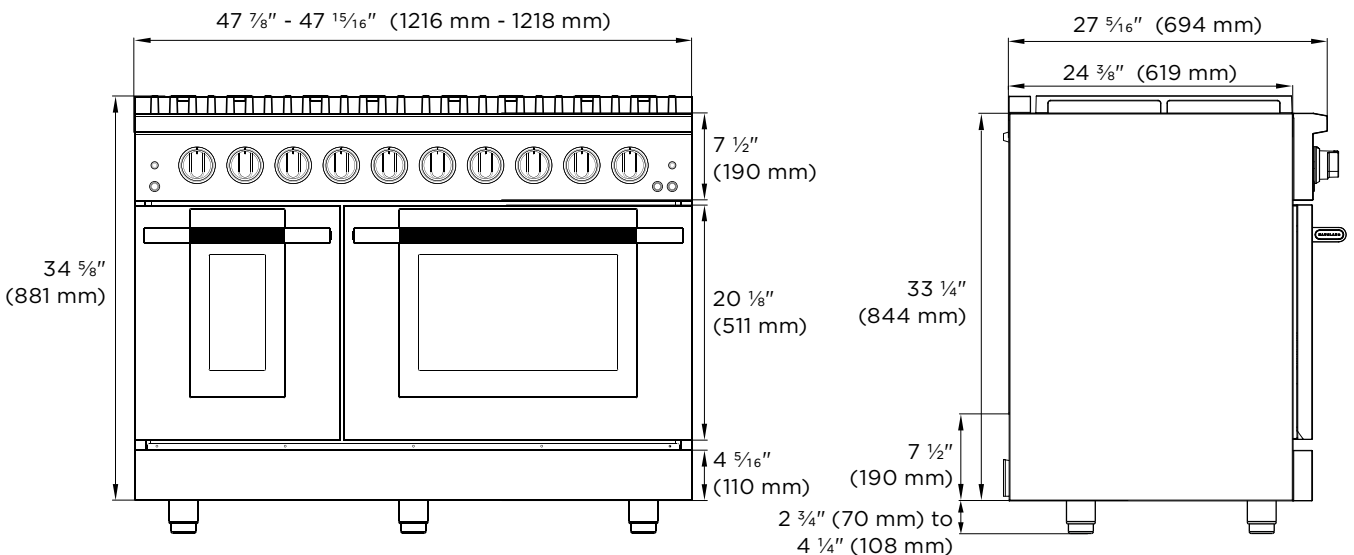

Package Contents

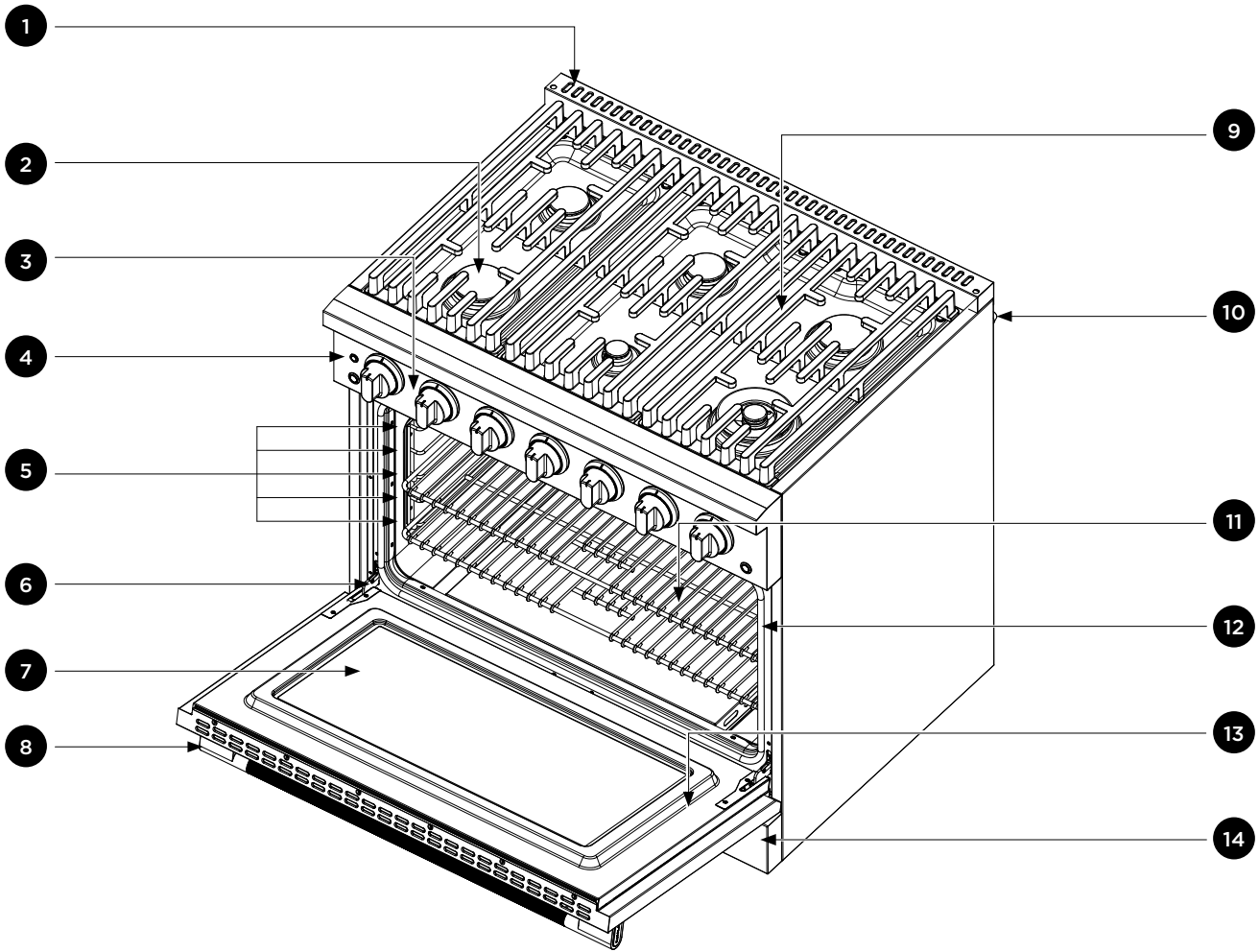

- | | | |
|------------------------|--------------------|----------------|
| 1 Oven Vent | 6 Door Hinge | 11 Rack x 2 |
| 2 Burner | 7 Oven Door Window | 12 Door Gasket |
| 3 Control Panel | 8 Oven Door Handle | 13 Oven Door |
| 4 Oven Indicator Light | 9 Grate | 14 Kick Plate |
| 5 Rack Positions | 10 Rear Rubber Pad | |

Tools Needed

Before you begin the installation process, gather the following tools:

- 1 Measuring Tape
- 2 Utility Knife
- 3 Philips Screwdriver
- 4 Hex Screwdriver
- 5 Safety Gloves
- 5 Wrench or Pliers
- 7 7mm Socket Wrench or Nut Driver
- 8 10mm Socket Wrench or Nut Driver
- 9 Male 1/2" or 3/4" flare Union Adapter
- 10 Aluminum Foil Tape
- 11 Pencil or Marker
- 12 1/8" (3mm) Flathead Screwdriver
- 13 Electric Drill & Extended Length Head Driver Bit
- 14 1/8" (3mm) Drill Bit (for Wood)
- 14 Pipe Wrench
- 15 15/16" (24mm) Combination Wrench
- 16 1/2" or 3/4" MPT Internal Thread Elbow
- 17 Allen Wrench / Hex Key (for Handle Installation) (Included)
- 18 Level
- 19 Adjustable Wrench
- 20 Needle Nose Pliers
- 21 Safety Goggles
- 22 Pipe-Joint Compound Resistant to LP Gas
- 23 Noncorrosive Leak-Detection Solution
- 24 Manual Gas Line Shut-Off Valve

ADDITIONAL PARTS

Check local codes, consult your gas supplier, and check the existing gas / electrical supply prior to beginning the installation process.

sections of this manual for further information and guidance on the additional parts a qualified installer will need to perform this installation.

See the "Electrical Connection" and "Gas Connection"

What's Included

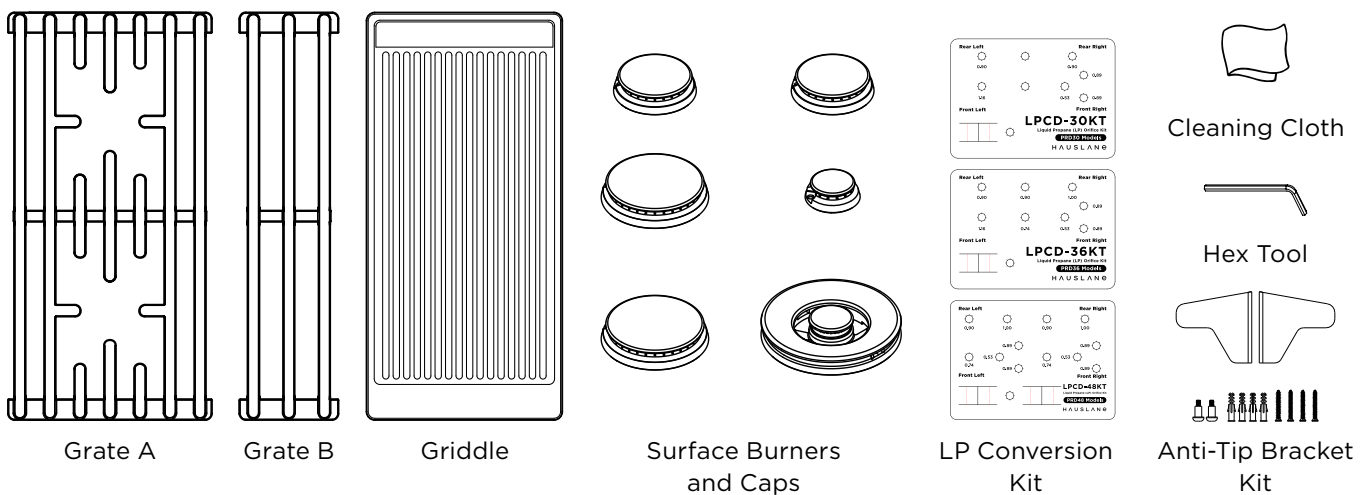

Surface Grates

- 30" Model: PRD30 (2A + 1B)
- 36" Model: PRD36 (3A)
- 48" Model: PRD48 (4A)

Griddle (GRD-01)

- 30" Model: PRD30 (Sold Separately)
- 36" Model: PRD36 (Sold Separately)
- 48" Model: PRD48 (1)

Surface Burners and Caps

- 30" Model: PRD30 (4)
- 36" Model: PRD36 (6)
- 48" Model: PRD48 (8)

LP Conversion Kit

- 30" Model: LPCD-30KT (1)
- 36" Model: LPCD-36KT (1)
- 48" Model: LPCD-48KT (1)

Cleaning Cloth

- 30" Model: PRD30 (1)
- 36" Model: PRD36 (1)
- 48" Model: PRD48 (1)

Hex Tool

- 30" Model: PRD30 (1)
- 36" Model: PRD36 (1)
- 48" Model: PRD48 (1)

Anti-Tip Bracket Kit

- 30" Model: PRD30 (1)
- 36" Model: PRD36 (1)
- 48" Model: PRD48 (1)

Control Panel

Before you begin the installation process, gather the following tools:

PRD30 (30")

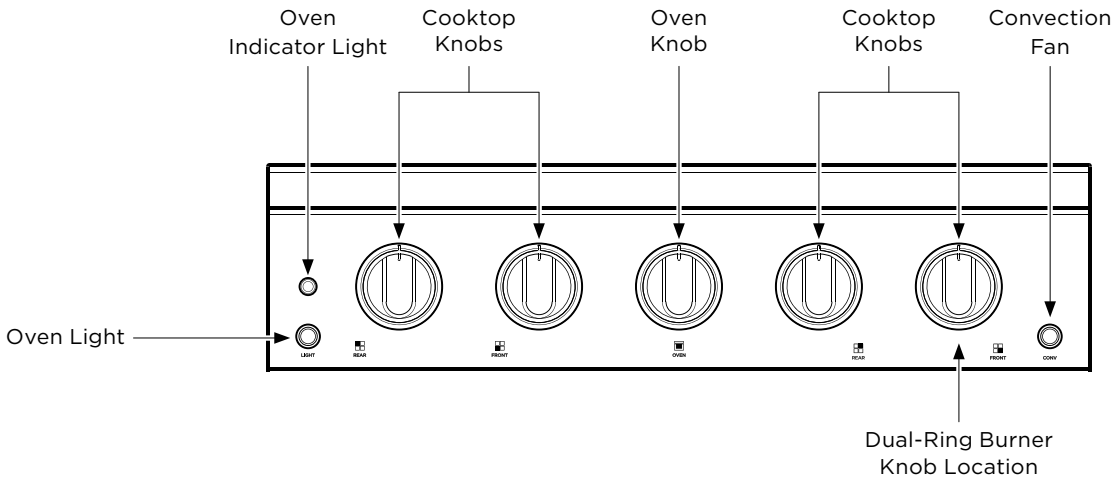

PRD36 (36")

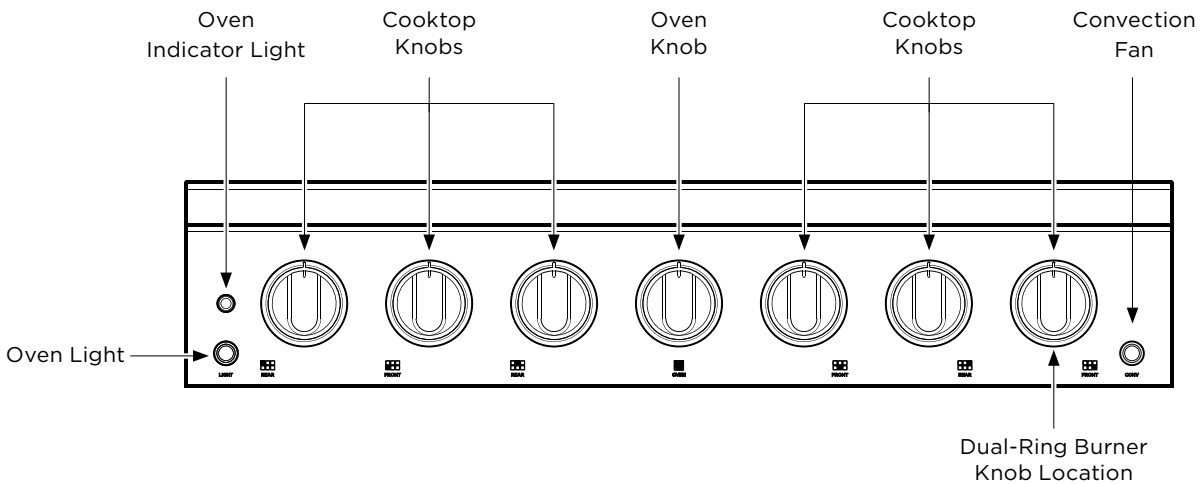

PRD48 (48")

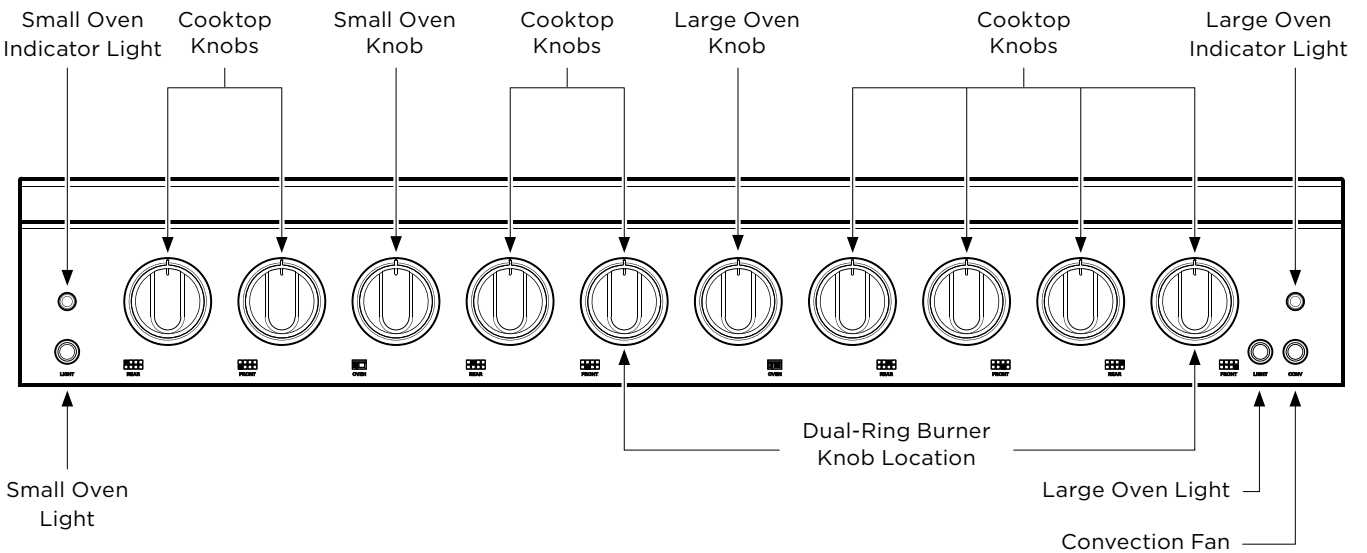

Preparation: What to Do Before Installation

Before installing your range, carefully follow these steps:

1. READ THIS MANUAL

Review all safety precautions on **pages 1 – 6** of this manual.

Read through all the steps. If you fail to read the instructions carefully, we will not be responsible for damages incurred on your part. We recommend hiring a certified technician to complete the installation.

2. GATHER YOUR TOOLS

Ensure you have all the necessary tools according to the previous page.

3. INSPECT THE UNIT

Unpack the unit and check your range for damage or missing parts. Plug it in to an outlet to ensure the fan and lights work. If anything is damaged or missing, contact the seller to get the issues solved. **DO NOT** throw away packaging until you're sure you are fully satisfied with the product.

4. RANGE PLACEMENT

Use the measurements provided on **page 13**. These represent minimum clearances from combustible surfaces. For cabinet cut-out dimensions, refer to **page 14**.

Ensure that on both sides of the range, the space between the countertop and the bottom of any upper cabinets is at least 18" (457 mm). See diagram on **page 13**.

All wall or floor openings behind the appliance **MUST BE** properly sealed.

The floor-mounted anti-tip bracket **MUST BE** installed. For installation instructions, see "**INSTALLING THE ANTI-TIP BRACKET**" on **page 24**.

A grounded electrical connection is required. See the "**ELECTRICAL SUPPLY**" section on **page 15** for specifications and safety precautions.

Confirm that proper gas supply connections are available. Refer to the "**GAS CONNECTION REQUIREMENTS**" section on **pages 17 – 19** and additional gas supply guidelines on **page 14**.

Refer to the diagram on **page 13** for required gas and electrical connection locations. The electrical cord length for all PRD models is 3 feet (914 mm).

Install the range **ONLY** under a ducted ventilation hood. **DO NOT** install under a downdraft ventilation system.

⚠ WARNING: The back of the range may not sit flush against the wall if gas or electrical connections are installed outside the recommended placement dimensions.

⚠ WARNING: It is the installer's responsibility to make sure the appliance is properly adjusted at the time of installation. Improper installation or adjustment is not covered under warranty.

⚠ WARNING: **DO NOT** store anything appealing to children in cabinets above the range. Children may try to climb on the appliance, leading to serious injury or burns.

5. ENSURE THERE IS PROPER HEIGHT CLEARANCE

To ensure safe and proper installation, follow these spacing requirements for your range and ventilation system. Refer to the visual guide below for reference.

SIDE VIEW & FRONT VIEW DIMENSIONS

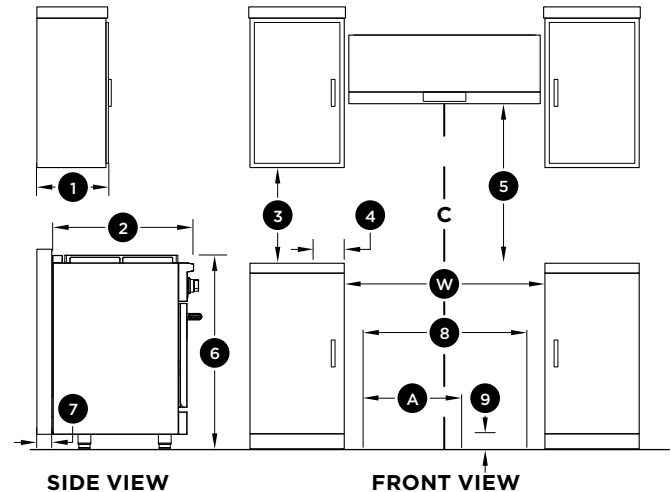

1. Standard depth of cabinet above cooktop:	13" (330 mm)
2. Depth from rear of chassis to front of control panel	27 5/16" (694 mm)
3. Minimum Clearance (Countertop to Cabinet, Both Sides of Range)	18" (457 mm)
4. Cooktop Side to Cabinet Clearance (Adjacent Working Areas)	6" (152 mm)
5. Minimum Clearance from Cooktop to Ventilation Hood	30" – 36" (762 – 914 mm) Depending on Your Hood Model
6. Cooktop Height from Floor (to Surface)	37 1/2" to 39" (953 – 991 mm) Depending on Leveling and Installation Height
7. Gas and Electrical Connection Area (Maximum Depth)	Max Depth of Gas / Electric Rough-in Area: 2 1/16" (71 mm) from the Rear Wall
8. Gas & Electrical Zone (Width)	PRD30: 22" (Approx.) PRD36: 28" (Approx.) PRD48: 39 7/8" (Approx.)
9. Gas and Electrical Connection Area (Maximum Height)	Vertical Space from Floor to Gas / Electric Rough-in Area: 4 1/2" (114 mm) from the Floor

OPENING WIDTH AND HOOKUP SPACING

Model	W (Opening Width)	A (Available Space - Gas and Electrical Hookup Zone)
PRD30	30 1/4" (768mm)	15" (381mm)
PRD36	36 1/4" (921mm)	21" (533mm)
PRD48	48 1/8" (1222mm)	31" (787mm)

NOTE: If you are not installing a ventilation hood above the range, you MUST allow for a minimum clearance of 42" (1067 mm) between the cooktop and any combustible surface above it.

RECOMMENDED CABINET CUT-OUT DIMENSIONS:

Model	Width	Depth	Height
PRD30	30 1/4" (768mm)	24 3/4" (629mm)	36" (914mm)
PRD36	36 1/4" (921mm)	24 3/4" (629mm)	36" (914mm)
PRD48	48 1/8" (1222mm)	24 3/4" (629mm)	36" (914mm)

PLANNING NOTE:

WIDTH: These dimensions allow 1/8" (3 mm) clearance on each side. Adjust based on your kitchen's exact layout.

DEPTH: Slightly deeper than standard 24" (610 mm) to allow the oven door to open fully and safely. The extra 3/4" (19 mm) also accommodates back bumpers so the unit can sit flush against the wall.

HEIGHT: Based on a standard cabinet height of 36" (914 mm) with the appliance legs at their lowest setting. Legs are adjustable by up to 1 1/2" (38 mm) to fit your preferred working height.

WARNING: OVERHEAD CABINET STORAGE

Avoid placing cabinets directly above the range. Combustible materials stored above may ignite, and metal objects may become dangerously hot. If you MUST install cabinets above the range, reduce fire risk by using a range hood that extends at least 5" (127 mm) beyond the cabinet front.

6.CHECK YOUR GAS SUPPLY AND ELECTRICAL CONNECTION

GAS SAFETY

DANGER: Serious risk of death, explosion, or fire exists unless all of the following safety steps are followed during gas hookup:

- Use a new gas supply line that is CSA International approved.
- Install a manual gas shut-off valve near the appliance.
- Securely tighten all gas connections using the proper tools and materials.
- ONLY a qualified professional should perform the installation. Examples include:
Licensed heating technicians
Authorized gas company representatives
Authorized appliance service personnel
Observe all governing codes and ordinances

IMPORTANT: FOLLOW ALL CODES AND REGULATIONS

This installation MUST comply with all local codes and ordinances

- If local codes do not apply, follow the National Fuel Gas Code ANSI Z223.1 / NFPA 54 (latest edition)
- In Canada, follow CAN/CGA B149 or CAN 1-1.1-M81, as applicable
- This appliance is design-certified according to ANSI Z21.1b-201 (latest edition)
- The appliance comes with information about the maximum inlet gas pressure, which must be adhered to for safety
- Gas Leak Testing You MUST test all connections for leaks following the manufacturer's instructions before use.
- Gas Line Requirements: Use either: A 1/2" metal gas line, or A certified flexible stove connector To seal threaded connections, use an approved compound resistant to liquefied petroleum gases to help prevent leaks.

NOTE: We recommend to use a NEW gas line or NEW flexible gas stove connector. These are available at your local hardware.

GAS SUPPLY

NATURAL GAS:

This appliance is designed to operate with natural gas but can be converted for use with liquid propane by a qualified technician.

The appliance is factory set for natural gas. Refer to the model / serial rating plate for approved gas types.

LIQUID PROPANE GAS:

A qualified service technician must perform any gas conversion. See page 19 for liquid propane conversion instructions.

DO NOT attempt to convert the appliance to a different gas type than listed on the model / serial rating plate without first consulting your local gas provider.

GAS REQUIREMENTS - ALL MODELS	
Natural Gas	WC
Supply Pressure	5" (12.5 mb)
Minimum Line Pressure	7" (17.5 mb)
Maximum Regulator Pressure	14" (34.9 mb), 0.5 psi (3.5 kPa)
Liquid Propane Gas	WC
Supply Pressure	10" (25 mb)
Minimum Line Pressure	11" (27.4 mb)
Maximum Regulator Pressure	14" (34.9 mb), 0.5 psi (3.5 kPa)

GAS CONNECTIONS

⚠ IMPORTANT: NEVER apply pressure directly to the appliance’s manifold pipe when tightening supply connections. Always support the pressure regulator with a wrench to prevent twisting. Twisting the manifold pipe can cause it to split and result in a dangerous gas leak.

⚠ NOTE: Check all piping connections for leaks using a soap solution (75% water, 25% dish soap). Factory connections can loosen during shipping due to vibration. Inspect all connections carefully and repair any that leak.

⚠ DANGER: NEVER use an open flame to check for gas leaks.

The appliance and its individual shut-off valve must be disconnected from the gas supply system during any pressure testing at pressures above ½ psig (3.5 kPa).

For pressure testing at or below ½ psig (3.5 kPa), the appliance must be isolated by closing its manual shut-off valve.

GAS LINE SHUT-OFF VALVE

To help prevent gas leaks, apply Teflon tape or an approved thread compound for natural gas or liquid propane to all threaded fittings.

Install a properly sized, agency-approved manual gas shut-off valve in an accessible location outside the range. This valve **MUST BE** located in the gas line leading to the appliance and allow for quick gas shutoff when needed.

This valve is not included with the appliance and **MUST BE** supplied by the installer.

For PRD30 and PRD36 ranges, install a ½" male flare union adapter. For PRD48 ranges, install a ¾" male flare union adapter. Connect to the ½" or ¾" MPT internal thread elbow at the regulator inlet. Use a wrench on the regulator fitting to avoid damage.

Install a ½" or ¾" male flare union adapter into the MPT thread of the manual shut-off valve. Make sure the valve is held securely to prevent it from turning during installation.

ELECTRICAL SUPPLY

⚠ DANGER: ELECTRIC SHOCK HAZARD

Failure to follow these electrical instructions can result in death, fire, serious injury, or electrical shock.

Any additions, changes, or conversions required for this appliance **MUST BE** performed by a qualified service technician. All work **MUST** follow the manufacturer’s instructions as well as local codes and regulations. The technician performing any gas or electrical conversion is responsible for ensuring proper and safe operation of the appliance.

DO NOT operate this appliance using a two-prong or three-prong wall adapter, and DO NOT use an extension cord under any circumstances. If your wall outlet is not a properly grounded four-prong receptacle, it must be replaced by a licensed electrician.

To avoid electrical shock or damage to the appliance, installation must be completed by a qualified installer or certified electrician. The appliance **MUST BE** properly grounded. The power supply **MUST** also have correct polarity. Reverse polarity can cause continuous sparking of the electrodes, even after ignition. If you are unsure about grounding or polarity, have the power supply inspected by a licensed electrician.

ELECTRICAL REQUIREMENTS PRD30 and PRD36 RANGES	
Electrical Supply	240 / 208 VAC, 60Hz
Service	25-Amp Dedicated Circuit
Total Amps	18
ELECTRICAL REQUIREMENTS PRD48 RANGES	
Electrical Supply	240 / 208 VAC, 60Hz
Service	35-Amp Dedicated Circuit
Total Amps	27

⚠ WARNING: This range is equipped with a 4-prong NEMA 14-50P plug to protect against electrical shock. **DO NOT** cut or remove the plug — it **MUST BE** plugged directly into a properly grounded wall receptacle.

⚠ CAUTION: WHEN SERVICING THE APPLIANCE:

- ALWAYS label wires before disconnecting
- Incorrect wiring can cause improper or dangerous operation
- After service is complete, verify all functions are working correctly

7.PRE - INSTALLATION SPECIFICATIONS AND INSTRUCTIONS

Before starting installation, carefully read and follow the safety precautions outlined on **pages 1 – 6**.

Each installation step includes specific safety instructions; however, it’s important to read all safety guidelines in full.

It is the installer’s responsibility to follow all clearance requirements outlined in this manual.

⚠ WARNING: RANGES ARE EXTREMELY HEAVY (OVER 200 LB / 91 KG).

TO AVOID INJURY OR DAMAGE:

- Use proper lifting equipment and adequate manpower when moving the appliance.
- Use caution with the adjustable steel legs — they can be damaged if the unit is dragged or dropped.
- Damage caused by improper handling may not be covered under warranty.

INSTALLATION PREP TIPS:

Choose a location that meets all safety and installation requirements specified in the manual.

Carefully unpack the appliance and all parts (including burners, burner caps, and cooking grates). Check that all parts listed on **page 11** are included and set them aside.

Gather all necessary tools as listed in the “**TOOLS NEEDED**” section on **page 11**.

DO NOT remove the protective film from the appliance until installation is complete—this helps prevent damage or scratches to the stainless steel, glass, or porcelain surfaces.

⚠ WARNING: NEVER lift the range by the oven door handle. Doing so may lead to personal injury or damage to the door and handle, which may void the warranty.

How to Install Your Range

When you’ve completed all the preparation steps, you’re ready to install your range.

1. TEST THE UNIT

Plug the unit into an outlet and press the touch panel to make sure that the unit is working.

⚠ IMPORTANT: If the range hood is not working properly, please contact us immediately (**1-800-929-0168** / **info@hauslane.com**).

⚠ DANGER: TIPPING RANGES CAN CAUSE SERIOUS INJURY OR DEATH.



TO PREVENT THIS:

The range **MUST BE** secured with a properly installed anti-tip bracket.

Failing to attach the anti-tip bracket to the wall correctly can result in fatal injury to a child or adult.

HOW TO CHECK ANTI-TIP INSTALLATION

To prevent tipping, the anti-tip device **MUST BE** properly installed. Secure it to the wall or the range as instructed in the installation manual. Then, tilt the front of the range slightly upward and slide it back into its final position, ensuring that the mounting pins slide under the brackets.

⚠ IMPORTANT: DO NOT operate the range without the anti-tip device engaged. Failure to follow this instruction can result in serious injury or death.

After moving or repositioning the range, **ALWAYS** re-engage the anti-tip device by following the steps outlined on **page 24** of the installation manual.

To test the anti-tip installation, gently pull the range from the back. If installed correctly, the range should not tip forward more than 4” (102 mm) from the wall. If it tips more than that, the anti-tip bracket is not properly secured and must be corrected before using the appliance.

⚠ DANGER: DO NOT allow the range to tip more than 4” (102 mm) from the wall — it may fall forward and cause injury.

IMPORTANT INSTALLATION TIPS:

NEVER remove the leveling legs — the anti-tip device relies on them to secure the unit.

NEVER stand or sit on the oven door.

The range is designed not to tip under normal use.

However, if the anti-tip bracket is missing or loose, applying weight to an open door can cause the entire unit to tip forward.

2. INSTALLING PARTS

BURNER SPREADS AND CAPS

After unpacking the range, set the cast iron grates aside and remove the burner spreads and caps from the storage area beneath the grates.

Place each burner spread on the correct burner, ensuring the hole fits securely over the white metal electrode spark tip. Then place the burner cap on top until it sits snugly.

If burner spreads (B) or caps (A) are not correctly positioned, burners may fail to ignite or **ONLY** ignite partially, as shown below:

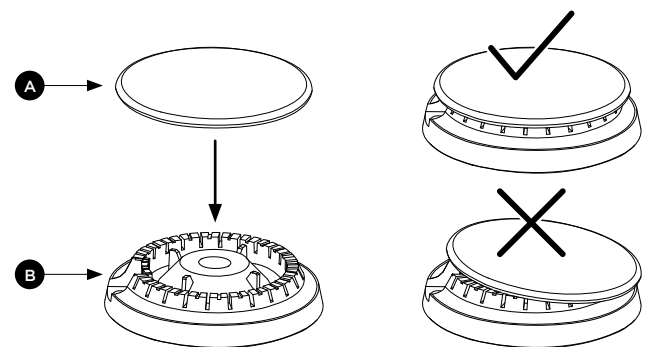

CAST IRON GRATES

Place the cast iron grates on the cooktop, being careful not to scratch the porcelain surface. Each grate has rubber feet and aligns with slots on the cooktop.

The PRD48 model includes a reversible enameled cast iron griddle. It should be placed vertically (front to back) over any of the four grates. **DO NOT** place it horizontally (side to side) across multiple grates.

KNOBS

1. PRD30 RANGE KNOBS (5 TOTAL)

To install the knobs, align each in the “OFF” position and press it straight onto the valve stems extending from the front of the cooktop, as shown at right.

The oven knob installs on the center valve, with burner knobs placed on either side. The dual function knob goes on the far right.

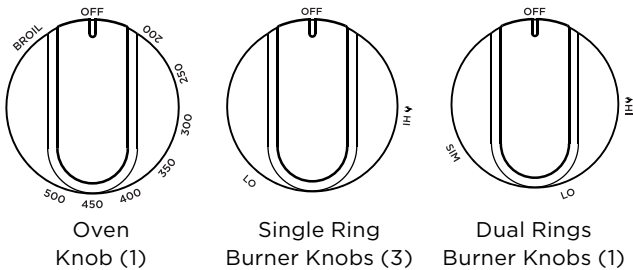

⚠ WARNING: The PRD30 and PRD36 ranges come with 1 brass dual function burner, and the PRD48 range includes 2 brass dual function burners. The burner knobs for those include a “SIM” setting, as outlined in the images below.

2. PRD36 RANGE KNOBS (7 TOTAL)

The oven knob installs on the center valve, with burner knobs placed on either side.

The dual function knob installs on the far right side of the range.

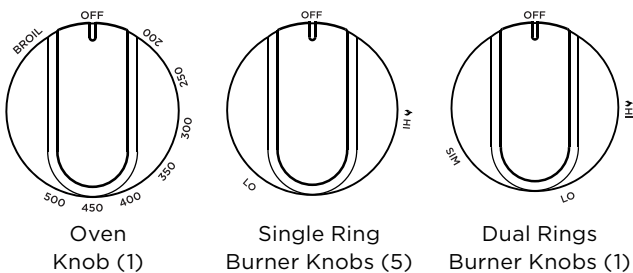

3. PRD48 RANGE KNOBS (10 TOTAL)

The oven knobs are installed on the two center valves, with the smaller oven knob on the left.

Burner knobs are placed on each side. One dual function knob goes directly to the left of the small oven knob, and the other installs on the far right side of the range.

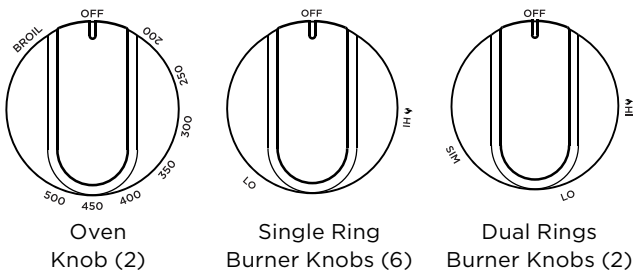

INSTALLING THE HANDLE



To install the oven door handle, align each bracket with the pre-installed mounting studs on both sides of the oven door, as shown in Figure 1 below.

Once aligned, locate the screw holes on the underside of each bracket base. Using the provided 3/64" (3 mm) Allen wrench or hex key, tighten both screws until the handle is securely in place, as shown in Figure 2 below.

If installed properly, the handle should sit perfectly level.

⚠ NOTE: While the diagram shows the PRD36 model, the handle installation process is the same for PRD30 and PRD48 ranges.

⚠ WARNING: Use care to not overtighten, or you risk stripping the screws and then your handle may be unstable or fall off, increasing the risk of injury or burns.

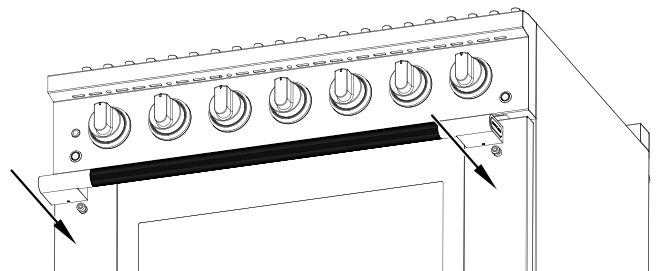

Figure 1

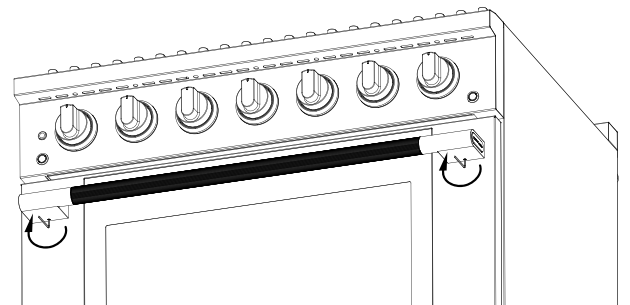

Figure 2

3. GAS CONNECTION REQUIREMENTS

This range is factory set to operate on natural gas (NG). If you intend to use liquid propane gas (LPG), the conversion MUST BE completed by a qualified installer before operating the appliance.

All gas connections must comply with national and local building codes. When using a flexible gas line connector, make sure the range is positioned so that it can connect easily to the manual shut-off valve.

⚠ DANGER: MANUAL GAS SHUT-OFF VALVE REQUIRED

The gas supply line must include an approved manual shut-off valve.

The shut-off valve must be easily accessible, located in the same room as the appliance.

DO NOT block access to the shut-off valve.

Be sure you know how and where to turn off the gas in case of emergency.

⚠ IMPORTANT: The pressure regulator, located at the gas inlet of the appliance, MUST remain in the supply line regardless of whether you are using natural gas or liquid propane.

The regulator is shipped with a clear plastic shield covering the inlet to prevent debris. This shield must be removed before connecting the gas line or coupler.

A flexible metal appliance connector should not exceed 3 feet (36 inches or 914 mm) in length for proper installation. In Canada, flexible connectors must be single-wall metal and less than 6 feet (1829 mm) in length.

⚠ WARNING: EXPLOSION HAZARDS

Read all safety precautions on **pages 1 to 6** before beginning installation.

ONLY use a CSA-approved gas supply line.

Install an approved manual shut-off valve.

Securely tighten all gas connections.

For liquid propane (LPG) installations, a qualified person must verify that the gas pressure does not exceed 3.5 kPa (14 inches W.C.P.). Qualified persons may include licensed heating professionals, gas company personnel, or authorized service technicians.

Failure to follow these instructions may result in fire, explosion, or death.

GAS INSTALLATION STEPS

1. Shut off the main gas supply before removing an existing appliance (if applicable). Leave it off until the new range is fully installed. DO NOT forget to relight pilot lights on any other gas appliances after restoring gas service.
2. Use a flexible metal connector (CSA-certified) to allow for movement, unless your local codes require hard piping.
 - NEVER reuse an old gas connector.
 - If using hard piping, carefully align all fittings.
 - Use pipe-joint compound rated for natural gas on all male pipe threads.
3. Connect the flexible gas line to the ½" regulator fitting located on the bottom left corner of the range (rear view).
4. Once connected:
 - Make sure all range controls are in the **OFF** position.
 - Turn on the main gas supply valve.
 - Check for leaks using a 75% water / 25% dish soap solution.
 - If bubbles appear, shut off the gas, tighten all connections, and retest.

⚠ WARNING: ALWAYS connect the gas line through the ½" fitting on the side of the pressure regulator, as shown in the diagram on the next page.

DO NOT remove the regulator access cap to connect gas. This cap is used only for:

- Liquid propane (LP) conversions
- Pressure adjustments

The regulator access cap MUST stay on at all times and should only be hand-tightened. Removing or tampering with this cap outside of its intended use may result in unsafe operation.

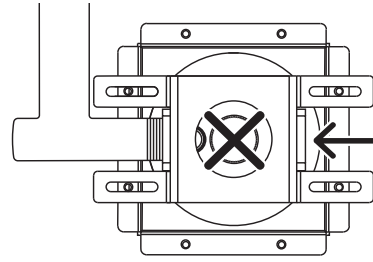

Regulator Location and Connection Notes

On all PRD series ranges, the pressure regulator is located at the bottom right corner when facing the front of the unit.

- From the rear view, the regulator appears on the bottom left.
- The diagram on the next page shows:
 - Proper gas hookup flow
 - Fitting locations
 - Required parts for connection

⚠ NOTE: The regulator and access cap are factory-installed. Other connection components, such as flare unions, shut-off valves, and flexible connectors, MUST BE supplied by the installer or customer.

⚠ IMPORTANT: The regulator access cap is used ONLY for liquid propane (LP) conversion or pressure adjustment. It is not for gas hookup. The cap should always be hand-tightened and remain in place during installation and operation.

SAFETY AND EXPLOSION HAZARDS

Read all safety precautions on **pages 1 to 6** before proceeding.

NEVER use an open flame to check for gas leaks. Doing so may result in a fire or explosion.

Tighten all connections securely to prevent leaks in the appliance or the gas supply line.

After connecting the gas line:

- Check that the control knobs align properly with their valve stems. Misalignment could mean the manifold pipe has shifted, which may cause the valve stems to rub against the control panel and create a gas leak.

During pressure testing:

- During any test pressure equal to or less than ½ psig (3.5 kPa), the appliance and its shut off valve must be disconnected from the main gas line.

Refer to the gas hookup diagram on the next page for proper connection flow and fitting locations. The pressure regulator and its access cap are pre-installed. All other gas connection components MUST BE supplied by the customer and installed by a qualified technician to ensure a safe and compliant installation.

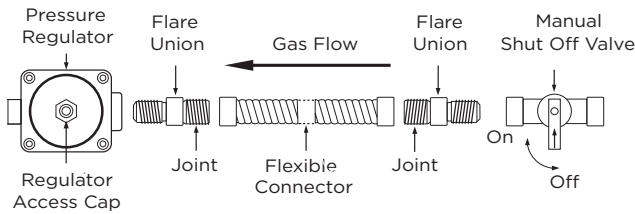

4. LIQUID PROPANE CONVERSION PROCEDURE (OPTIONAL)

⚠ CAUTION: SHUT OFF GAS AND POWER FIRST

Before beginning the conversion:

- Turn off the gas supply to the appliance
- Then disconnect the electrical power
- DO NOT attempt the conversion while the appliance is connected to either gas or electricity.

⚠ IMPORTANT NOTES

If you plan to use liquid propane (LPG), the conversion MUST BE completed before installing the anti-tip device.

If you're using factory-installed natural gas and DO NOT need to convert to propane, you can skip ahead to **page 24**.

Your appliance comes with a conversion kit. Be sure to use the correct one based on your model:

PRD30: LPCD-30KT

PRD36: LPCD-36KT

PRD48: LPCD-48KT

⚠ WARNING: SAFETY MEASURES

Read all safety precautions on **pages 1-6** before proceeding.

The conversion MUST BE completed by a qualified service technician, following both the kit instructions and local codes.

Skipping this conversion when using LPG may result in serious injury or property damage.

The service agency performing the conversion is responsible for its accuracy and safety.

Once converted, the LPG gas supply MUST provide:

Minimum: 2.5 kPa (10" W.C.P.)

Maximum: 3.5 kPa (14" W.C.P.)

⚠ WARNING: QUALIFIED INSTALLATION REQUIRED

This conversion kit MUST BE installed by a qualified service agency in full accordance with:

- The manufacturer's instructions
- All applicable building codes and regulations

If these instructions are not followed exactly, the result may be:

- Fire
- Explosion

- Carbon monoxide production
- Serious injury or loss of life

The installation is not complete until the converted appliance has been tested and verified for proper operation as described in the conversion kit instructions.

CHECKING MANIFOLD PRESSURE

A licensed technician should check manifold pressure using:

- Their own manometer
- A Hauslane-supplied test point adapter
- ¼" (6 mm) tubing

The figure references the PRD36 range, but the procedure is the same for all PRD models.

To perform the test:

1. By hand, remove the burner spread and burner cap from either the rear left or front left burner on the cooktop.
2. Using a ⅝" (7 mm) nut driver or wrench, remove the gas orifice from the bottom of that burner.
3. Insert the test point adapter into the orifice hole.
4. Turn the burner control knob to the "HI" position.
5. While pressing and holding the knob, use the manometer to check the pressure.

TARGET MANIFOLD PRESSURES:

Natural Gas: 1.2 kPa (5 inches W.C.P.)

Liquid Propane Gas: 2.7 kPa (11 inches W.C.P.)

The upstream line pressure must be at least 0.25 kPa (1 inch W.C.P.) higher than the manifold pressure for an accurate reading.

The pressure regulator on this appliance can safely accept up to 3.5 kPa (½ PSI or 14 inches W.C.P.) of input pressure. If the line pressure exceeds this value, a step-down regulator MUST BE used.

⚠ CAUTION: TEST ONLY SIDE BURNERS

DO NOT perform pressure testing on dual function burners. ONLY use one of the far-left burners on the range for accurate pressure readings.

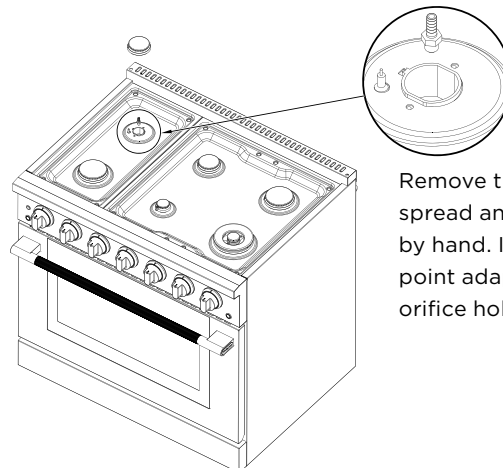

Remove the burner spread and burner cap by hand. Insert the test point adapter into the orifice hole.

⚠ If your LP conversion kit did not include the test point adapter or ¼" tubing, contact Hauslane Customer Experience at **1-800-929-0168** for assistance.

⚠ DANGER: ALWAYS disconnect electrical power to the appliance before performing any service. Failure to do so may result in shock, fire, or death.

STEPS TO ADJUST THE REGULATOR FOR PROPANE USE:

Shut off the gas supply by closing the manual shut-off valve. Purge the gas line by pressing the range knobs several times — this ensures no gas remains in the system.

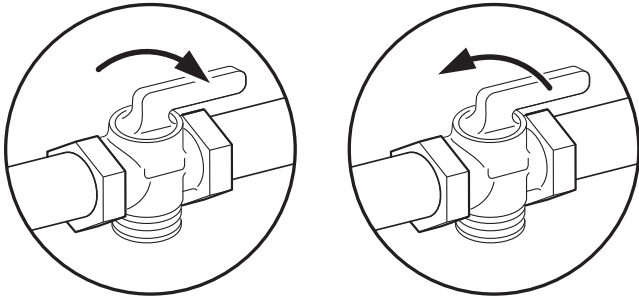

Unscrew the regulator access cap by hand or with a suitable pipe wrench (refer to diagram).

Remove the regulator pin (See diagram below):

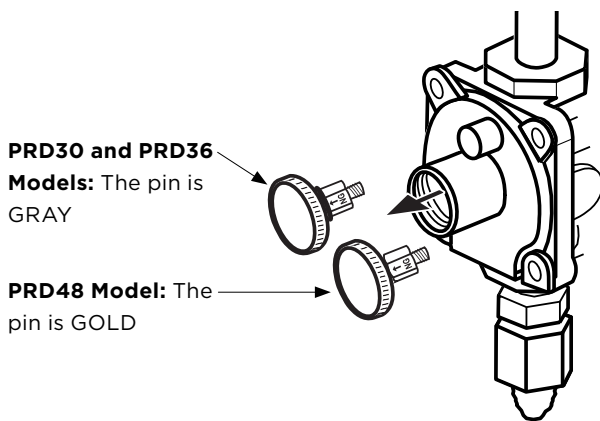

You'll reinstall this pin in the correct position based on your gas type — the next section will guide you through it.

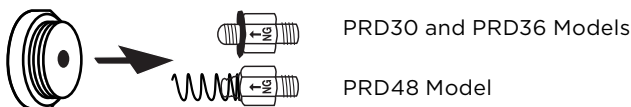

For PRD30 and PRD36 models, locate the gray regulator pin. It is not attached to a spring. Unscrew the pin, flip it over, and screw it back into the regulator cap as shown in the diagrams. For PRD48 model, the gold regulator pin is attached to a spring. Unscrew the pin, reverse it, and screw it back into the regulator cap. Make sure the spring fits snugly when tightening to ensure proper pressure regulation.

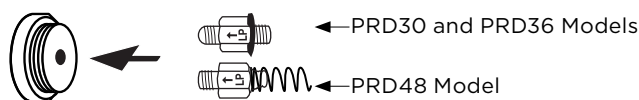

Once the pin is reversed, screw the regulator access cap back into the regulator body. Then reconnect the regulator to the nipple and flare union as illustrated. DO NOT overtighten.

⚠ NOTE: The pressure regulator and cap come pre-installed on your unit. All other gas connection parts shown in the diagram (flare unions, shut-off valve, etc.) MUST be supplied by the customer for a qualified installer to complete the hook-up safely.

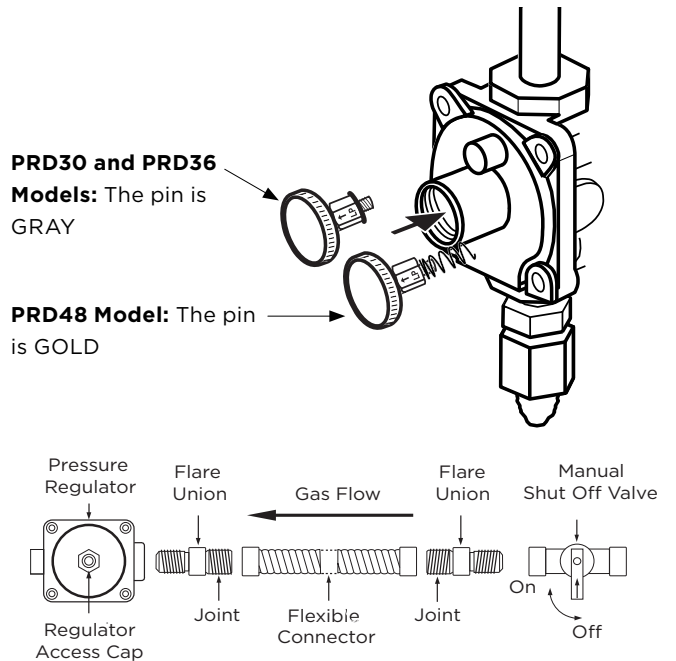

CHANGING BURNER ORIFICES

First, remove the burner grates, burner caps, and burner spreads. Then use a 3/32" (7 mm) nut driver or wrench to unscrew the existing natural gas orifices. Each orifice is labeled for its correct location, so read the labels carefully before replacing.

Replace each with the matching liquid propane orifice. DO NOT force or overtighten the orifices, as this can damage the burner base and affect flame performance.

For dual burners, there are three orifices per burner. One is in the center and two are located on the sides. Use a 3/32" (7 mm) wrench to remove and replace the side orifices as well.

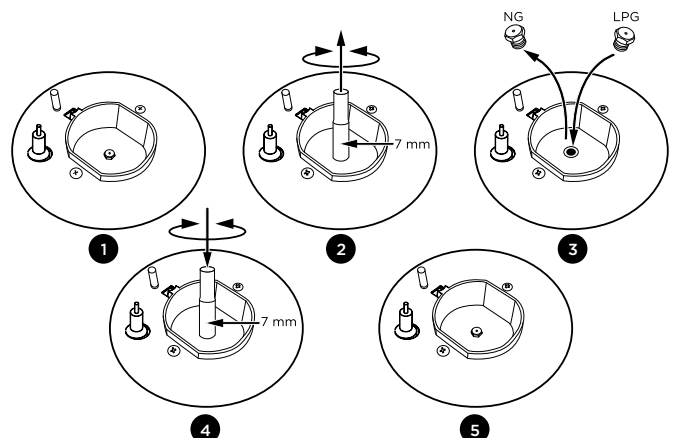

⚠ WARNING: HANDLE GAS COMPONENTS WITH CARE

Save all removed natural gas orifices — you will need them if converting back to NG in the future.

Be careful when handling metal components, especially sharp or threaded parts.



Use proper tools and support to avoid damaging the appliance during conversion.

LIQUID PROPANE CONVERSION (CONTINUED) ORIFICE NUMBERS

⚠️ INSTALLATION TIP: To help prevent any mix-ups during installation, it's best to remove all existing natural gas (NG) orifices first, and then install the liquid propane (LPG) orifices.

⚠️ IMPORTANT: Each orifice has a number indicating its flow diameter printed on the body. You **MUST** install the correct orifice in the exact location as noted in the illustrations and the orifice table below for the **PRD30 MODEL**.

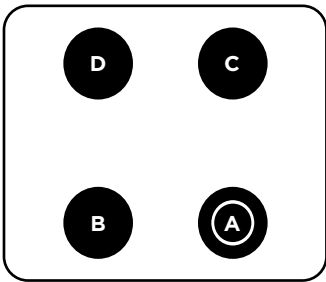
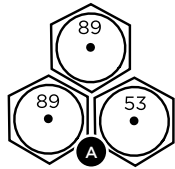
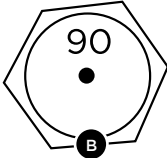
⚠️ NOTE: For dual burners (**A**), make sure to replace all three orifices: one in the center and two on the sides.

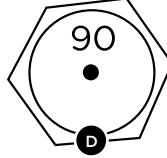

PRD30 ORIFICES				
Burner Layout	Burner	LPG (Orifices)	NG	LPG
 <p style="text-align: center;">FRONT</p>	A		1.36 (2) +0.73	0.89 (2) + 0.53
	B		1.36	0.90
	C		1.79	1.16
	D		1.36	0.90

LIQUID PROPANE CONVERSION (CONTINUED) ORIFICE NUMBERS

⚠️ INSTALLATION TIP: To help prevent any mix-ups during installation, it's best to remove all existing natural gas (NG) orifices first, and then install the liquid propane (LPG) orifices.

⚠️ IMPORTANT: Each orifice has a number indicating its flow diameter printed on the body. You **MUST** install the correct orifice in the exact location as noted in the illustrations and the orifice table below for the **PRD36 MODEL**.

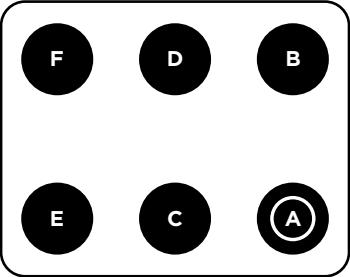
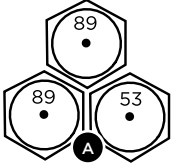
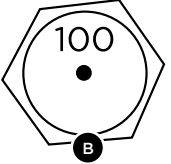
⚠️ NOTE: For dual burners **(A)**, make sure to replace all three orifices: one in the center and two on the sides.

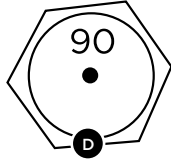
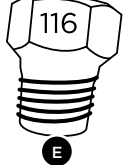
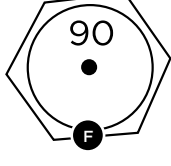



PRD36 ORIFICES				
Burner Layout	Burner	LPG (Orifices)	NG	LPG
 <p style="text-align: center;">FRONT</p>	A		1.36 (2) + 0.73	0.89 (2) + 0.53
	B		1.57	1.00
	C		1.07	0.74
	D		1.36	0.90
	E		1.79	1.16
	F		1.36	0.90

LIQUID PROPANE CONVERSION (CONTINUED) ORIFICE NUMBERS

⚠️ INSTALLATION TIP: To help prevent any mix-ups during installation, it's best to remove all existing natural gas (NG) orifices first, and then install the liquid propane (LPG) orifices.

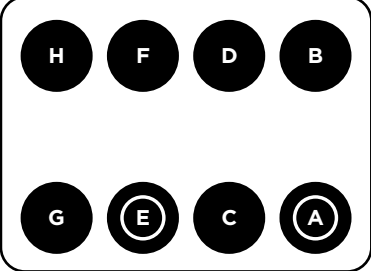
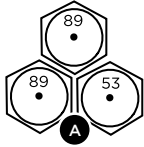
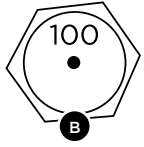
⚠️ IMPORTANT: Each orifice has a number indicating its flow diameter printed on the body. You **MUST** install the correct orifice in the exact location as noted in the illustrations and the orifice table below for the **PRD48 MODEL**.

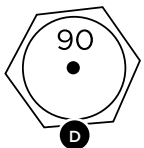
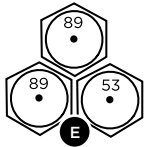
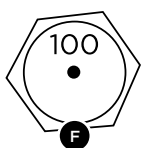
⚠️ NOTE: For dual burners (**A and E**), make sure to replace all three orifices: one in the center and two on the sides.

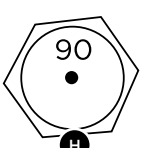
PRD48 ORIFICES				
Burner Layout	Burner	LPG (Orifices)	NG	LPG
 <p style="text-align: center;">FRONT</p>	A		1.36 (2) + 0.73	0.89 (2) + 0.53
	B		1.57	1.00
	C		1.07	0.74
	D		1.36	0.90
	E		1.36 (2) + 0.73	0.89 (2) + 0.53
	F		1.57	1.00
	G		1.07	0.74
	H		1.36	0.90

INSTALLING THE ANTI-TIP BRACKET

⚠ DANGER: A child or adult can be seriously injured or killed if the range tips forward. DO NOT operate the appliance without the anti-tip device in place. Failure to install it properly can result in death or serious burns.

STEP-BY-STEP INSTALLATION INSTRUCTIONS

1. Position the range in its cabinet space. Adjust the leveling feet to the desired height. Slide the range forward slightly to access the back wall.
2. Attach the anti-tip brackets to the wall:
 - Drill two holes per bracket
 - Secure with the 4 included screws
 - The mounting side of the bracket must face the cabinet
 - For concrete or tile walls, use the included anchors – tap them in first with a hammer, then install screws
3. Set bracket height by measuring from the floor to the bottom of each side panel (see manual diagrams).
 - Use a level to ensure both brackets are installed evenly.
4. Install the mounting pins:
 - These are included in your anti-tip kit
 - Screw one pin into each side of the oven base recess, left and right
5. Recess width reference by model:
 - **PRD30:** 28 1/4" (718 mm)
 - **PRD36:** 34 1/4" (870 mm)
 - **PRD48:** 46 1/8" (1172 mm) **NOTE:** Cabinet dimensions may vary, so measure carefully before securing the brackets.
6. Slide the range back into place:
 - Slightly tilt the front of the range upward, then push it gently toward the wall
 - Make sure each mounting pin slides under its bracket

⚠ WARNING: Gently pull the range from the rear. If the anti-tip device is correctly installed, the mounting pins will catch on the brackets, and the range will not tip more than 4" (102 mm) from the wall.

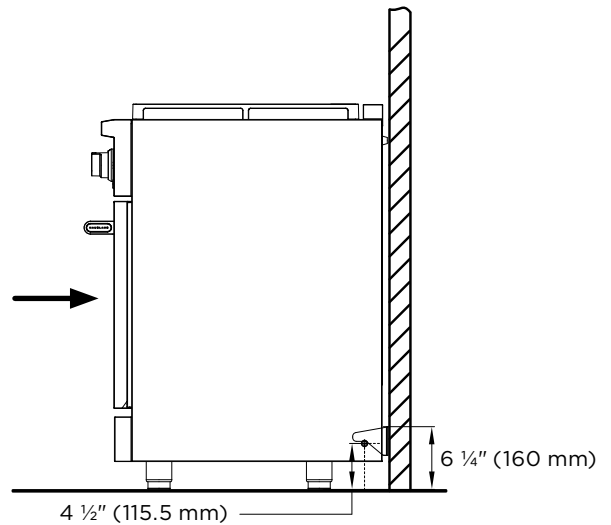

FINISH INSTALLATION

1. Once the gas connection and anti-tip brackets are securely installed, plug the range's NEMA 14-50 electrical cord into a properly grounded 4-prong outlet.

⚠ WARNING: The outlet must remain easily accessible after installation. The power supply cord MUST NOT exceed 122°F (50°C) above room temperature at any point.

2. Slide the range into its final position.
3. Check the anti-tip installation by gently pulling on the back of the range. It should not tip more than 4" (102 mm).
4. Install the burner spreads by aligning each one so the white spark tip fits into the hole in the spread.
5. Place the burner caps snugly and level on top of each spread.
6. Carefully place the grates on the cooktop. Avoid scratching the burner caps, burner spreads, or porcelain surface.
7. Use a level to adjust the front and / or rear feet until the range is flush with your countertop and fully level. A level appliance helps prevent uneven cooking or baking.
8. After completing all connections:
 - Make sure all burner and oven controls are in the "OFF" position
 - Turn on the main gas supply valve

⚠ WARNING: It may take a few minutes for gas to flow freely after connection. You may need to try lighting the burners or oven a few times. Refer to the User Manual for flame adjustment and lighting instructions.

⚠ NOTE TO INSTALLER: Leave this installation manual with the homeowner. It should be kept for local inspections, future reference, and troubleshooting. Refer to the User Manual for full operation, maintenance, and safety information.

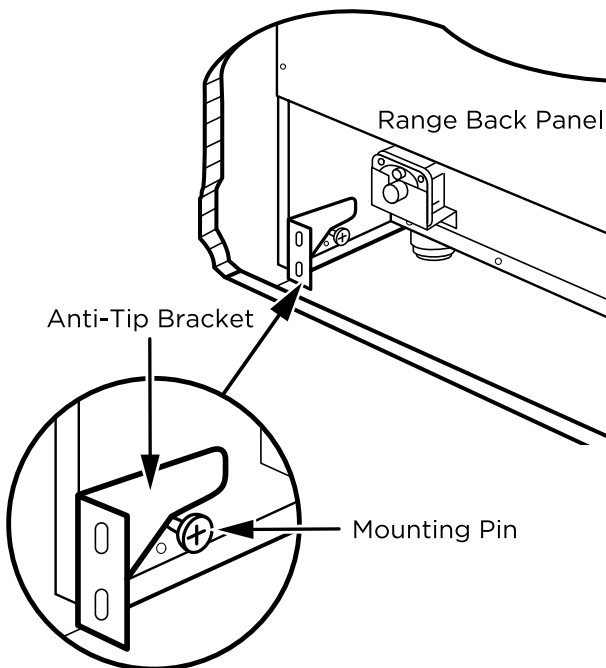

How to Use Your Range

1. COOKTOP SAFETY

- ALWAYS turn burner knobs to the "OFF" position before removing cookware.
- DO NOT lift the cooktop. Doing so may cause damage or affect the appliance's performance.
- If the appliance is near a window, DO NOT hang long curtains that could blow over the burners and catch fire.
- DO NOT operate burners without cookware on the grate. The heat can damage the grate's finish without a pan to absorb it.

2. GUIDELINES FOR USING SURFACE BURNERS

PRD model ranges use electric ignition and include an auto re-ignition feature. If a flame goes out unexpectedly—such as from a breeze—the system will detect it and automatically reignite the burner if gas is still flowing.

When you press one burner knob, you may see sparking at all burners. This is normal. ONLY the selected burner will release gas.

Keep burners clean—especially after spills or boil-overs. Residue can clog the igniter or burner notches and prevent the burner from lighting or working properly.

Burner flames should be steady and blue. Occasional yellow tipping is normal, but avoid flames that flicker or spread unevenly around the burner cap.

3. MANUAL FLAME ADJUSTMENT

Each range includes a manual flame adjustment feature if burner flames are uneven or appear too yellow or orange. The range is designed to keep flames at the proper level, but adjustments can be made if needed.

⚠ NOTE: ALL BURNER FLAMES ARE FACTORY-SET AND TESTED BEFORE SHIPPING. WE RECOMMEND CONTACTING HAUSLANE CUSTOMER EXPERIENCE BEFORE ATTEMPTING ANY ADJUSTMENTS.

Follow these steps:

1. Light one burner and set it to the lowest setting. Then, carefully pull the knob straight off.
2. Inside each burner is an adjustment screw. Using a 2 mm x 50 mm flathead screwdriver, locate the screw and turn it left or right until the flame reaches the desired minimum. Use a flashlight if the screw is hard to see. Make sure the flame stays lit when switching from **HI** to **LO**.

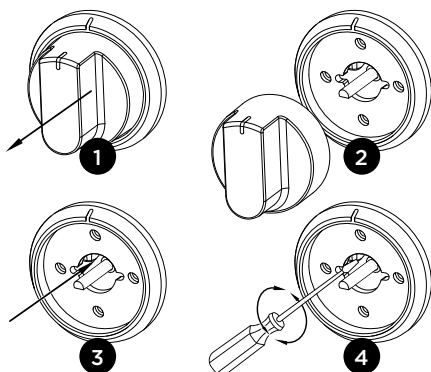

For single burners, the adjustment screw is located on the right side of the control switch.

For dual burners, there are two adjustment screws located on the left side of the control switch—one for the inner ring and one for the outer ring.

⚠ NOTE: The high flame setting cannot be lowered. For dual burner knobs on all models, two screws may need adjustment—one for the inner ring and one for the outer ring. These screws are on the left side of the adjustment valve.

4. SURFACE BURNER OPERATION

1. To ignite a surface burner, press in the knob for the burner you want to use—this releases gas (see first image below).
2. Turn the knob counter-clockwise to the "HI" position (see second image). You'll hear a spark from the metal electrode near the white ceramic tip. Wait 0.5 to 2 seconds for the burner to light.
3. Once lit, turn the knob to adjust the flame to your desired heat level. If the flame goes out and DOES NOT reignite automatically, turn off the burner and repeat the process.

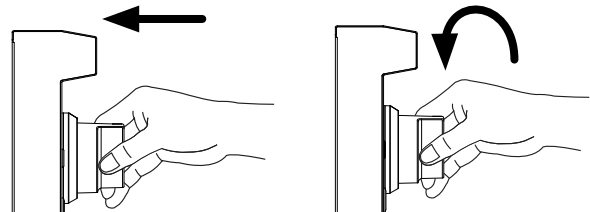

⚠ WARNING: ALWAYS handle the cooktop and oven knobs with care.

- Turn knobs gently and ONLY as far as needed to reach the desired setting.
- Avoid turning knobs past their highest setting.
- DO NOT force the knobs in the wrong direction — doing so may cause permanent damage.

USING THE BURNERS CORRECTLY

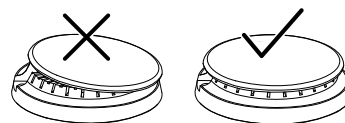

1. ALWAYS confirm that burner caps are installed correctly before use.



2. The flame on the cooktop burners should be fully blue and even, as shown in the diagram.

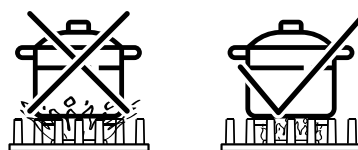

3. NEVER let flames rise up around the sides of your cookware—this is a safety risk and can also damage pots and pans.

⚠ WARNING: Burner Cap Positioning

ALWAYS make sure the black burner cap is properly installed and centered on the burner spread before igniting. An off-center or missing burner cap can lead to uneven flames and increase the risk of injury.

SURFACE BURNER KNOB FUNCTION

SINGLE RING BURNER KNOB

HI: Maximum Flame Height
LO: Minimum Flame Height

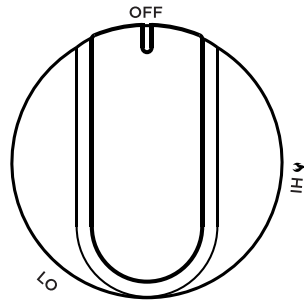

DUAL RING BURNER KNOB

HI: Maximum Flame Height
LO: Minimum Flame Height
SIM: Simmer Mode

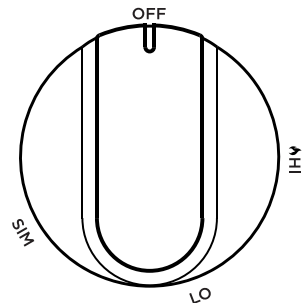

PRD models include special dual burners with a simmer setting (the PRD48 model features two). Use this setting for melting chocolate or butter, cooking rice and delicate sauces, simmering soups and stews, or keeping food warm.

For all other cooking needs, adjust each knob as needed between the minimum and maximum flame settings, as shown below:

HEAT SETTINGS AND SIMPLE COOKING GUIDE	
SIM (Dual Rings Burners Only)	Gentle Simmering, Melting Chocolate and Butter, Cooking Rice, Delicate Sauces, Soups, Stews, and Keeping Food Warm. (Dual Burners ONLY)
LOW	Melting Larger Quantities of Food.
Low-Medium	Low-Temperature Frying, Simmering Larger Quantities, Heating Milk, Cream Sauces, Gravies.
Medium	Sautéing, Browning, Braising, Pan-Frying, Maintaining a Slow Boil.
Medium-Hi	High-Temperature Frying, Pan Boiling, Maintaining Slow boil on Larger Quantities.
HI	Boiling Liquids Quickly, Deep Frying. Also the Ignition Setting.

SURFACE BURNER FLAME SIZE

When adjusting burner knobs, turn them slowly until you reach your desired flame size.

Flames should be steady and mostly blue. Some flickering of orange or yellow is normal.

If flames appear consistently orange or yellow, check for environmental factors like candles, cleaning products, or other changes that may affect flame color.

If the issue continues after a liquid propane conversion by a technician, the conversion may not have been completed properly. Ensure all orifices are correctly positioned. If using natural gas, contact your installer or gas company for assistance.

⚠ WARNING: COMBUSTION SAFETY

Gas appliances may emit small amounts of substances such as benzene, carbon monoxide, formaldehyde, and soot, mainly due to incomplete combustion of natural gas or propane.

Properly adjusted burners with clean blue flames help minimize these emissions.

Ventilate your kitchen by opening windows or using a ventilation fan or range hood to reduce exposure.

⚠ WARNING: When using the cooktop for the first time, burners may take a moment to ignite as gas fills the system. DO NOT hold the burner knob pushed in for longer than a few seconds.

If the burner does not ignite within four seconds, turn the knob off and wait at least five minutes to let any gas clear before trying again.

POWER FAILURE

If a burner doesn't ignite within 4 seconds, turn the knob off and wait at least 5 minutes to allow gas to clear before trying again. Refer to the relighting instructions on **page 25**.

If your power goes out, you can still light the surface burners manually. Hold a lit match near the burner, turn the knob counterclockwise to "HI", and remove the match once the burner lights. Adjust the flame as needed.

⚠ NOTE: The oven will not operate without electricity.

COOKTOP MAINTENANCE

To prevent staining or discoloration, clean the cooktop after each use. Wipe up acidic or sugary spills once the surface has cooled.

Your sealed burners are removable and not fixed to the cooktop. Spills or boil-overs won't seep underneath but should still be cleaned after each use.

Always disconnect the appliance and let it cool before cleaning. For hygiene and safety, the cooktop must be kept clean at all times.

When using spray cleaners, avoid spraying electrical components, the thermostat, or the bulb.

Clean up any food or liquid spills on the cooktop, oven sides, or oven bottom before cooking to prevent smoke or fire hazards. For detailed cleaning tips, see the “Care and Maintenance” section.

⚠ WARNING: The U.S. Department of Agriculture advises not to hold foods between 40 °F and 140 °F (4 °C to 60 °C) for more than 2 hours. Cooking raw foods below 275 °F (135 °C) is not recommended.

BURNER GRATES

Grates must be correctly positioned before use. Misaligned grates can scratch the cooktop and affect burner performance.

NEVER operate burners without proper cookware on the grates.

If using a wok, a wok support ring is required. Wok support rings are sold separately.

For best results, always center cookware directly on the grate to ensure even heating and maximum efficiency. See below for more.

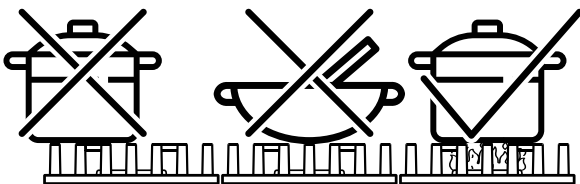

GRIDDLE OPERATION (PRD48 RANGE)

Before using for the first time, wash the cast iron griddle thoroughly with warm, soapy water to remove any dust or protective coating. Rinse with clean water and dry with a soft, lint-free cloth.

Place the griddle vertically (front to back) on any of the four burner grates until it slides into place. DO NOT position the griddle horizontally (side to side) across multiple grates.

For even heating, turn on both the rear and front burners beneath the griddle.

⚠ WARNING: The griddle surface can stay hot for several minutes after use. Allow it to cool completely before moving or cleaning.

5. OVEN OPERATION

PRD30 AND PRD36 MODELS

To turn on the oven, press in the knob and rotate it counter-clockwise. When the oven reaches the set temperature, the white indicator light next to the knob will turn off.

To use the Broil function, turn the knob clockwise to the Broil setting. The white indicator light will turn on when active.

PRD30 and PRD36 ranges use one oven knob, with temperature settings from 200°F to 500°F (93°C to 260°C), plus a Broil setting.

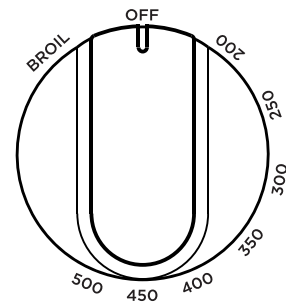

Oven Knob

PRD48 MODELS

The PRD48 range has two oven knobs—one for the small oven and one for the large oven. The large oven’s maximum bake temperature is 500°F (260°C), and the small oven’s is 500°F (260°C). Both ovens also include a Broil setting.

To operate either oven, press in the knob and turn it counter-clockwise. The white indicator light next to the knob will turn off once the oven reaches the set temperature.

To activate the Broil function, turn the knob clockwise to the Broil setting. The white indicator light will turn on when the function is active.

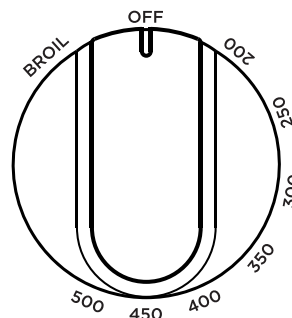

Small Oven Knob

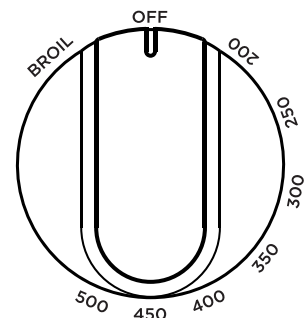

Large Oven Knob

CONVECTION FAN

Push the Convection Fan button to turn the convection fan On or Off.



CONV

LIGHT

Push the Light button to turn the oven lights On or Off.



LIGHT

OVEN VENTS

The oven vent is located behind the oven, beneath the back splash. DO NOT block the vent ducts while the oven is in use. Maintaining airflow is essential for safe operation.

DO NOT touch the oven vent or nearby surfaces while the oven is running, as they may become hot and cause burns.

⚠ NOTE: It’s normal for steam or moisture to vent and collect on the cooktop. This is especially common when baking moist foods or during colder months, when condensation is more likely due to the temperature difference. The water is harmless and non-corrosive.

INTERIOR OVEN SAFETY

⚠ WARNING: NEVER cover any slots, holes, or passages in the oven bottom, and DO NOT cover entire oven racks with materials like aluminum foil. Blocking airflow can lead to poor cooking performance and may increase the risk of carbon monoxide buildup.

Using aluminum foil in the oven can also trap heat, creating a fire hazard. Avoid placing aluminum foil on any porcelain surfaces inside the oven, as it may cause permanent damage.

Using aluminum foil anywhere on the range may void the manufacturer's warranty.

OVEN FUNCTIONS AND FEATURES

BAKE

In Bake mode, heat comes from the bake elements at the bottom of the oven and circulates naturally. This is a traditional baking method.

To use Bake, turn on the oven and select a temperature between 200°F and 500°F (93°C to 260°C). For the PRD48 model, the small oven has a max bake temperature of 500°F (260°C).

⚠ NOTE: Preheating usually takes 12 – 25 minutes, depending on the desired temperature.

For best results, Hauslane recommends waiting until the oven is fully preheated before placing food inside.

CONVECTION BAKE

Convection bake uses the bake elements at the bottom of the oven along with a convection fan in the rear to circulate hot air evenly. This method allows faster, more even cooking at lower temperatures.

To activate, turn on the oven, set the temperature, and press the Convection button located on the oven's front panel.

For best convection results, Hauslane recommends allowing the oven to fully preheat before adding food.

BROIL

When broiling, heat radiates from the top element for fast, even cooking. Use this function to sear meats or brown the tops of pre-cooked dishes.

⚠ NOTE: Keep the oven door closed during broiling (both doors for the PRD48 model).

⚠ WARNING: ALWAYS keep a close eye on food when using the broiler. This function heats quickly and can burn food in just a few minutes if left unattended.

TO ACTIVATE THE BROILER

1. Place food on an oven-safe baking sheet or broiler pan.
2. Position the oven rack at the desired height and place the pan directly under the broil element. If preheating, wait until the broiler is hot before placing the pan.

3. Turn the knob clockwise to “**BROIL**.” The blue indicator light will turn on.

PREHEATING AND OTHER BROILING TIPS

Preheating is recommended for searing steaks and meats. Turn the knob to “**BROIL**” and wait about 2 minutes. (Preheating is not required when broiling well-done meat.)

ALWAYS remove empty pans from the oven before preheating to prevent sticking.

The indicator light stays on until the oven reaches temperature or the knob is turned off.

Fully extend the oven rack to the stop position before turning or removing food.

For best results, use a broiler pan (not included) with an insert to drain grease and keep it away from the heat.

The broil setting operates at 500°F (260°C).

⚠ WARNING: NEVER use a broiler pan without the insert. DO NOT cover the broiler pan insert with aluminum foil, as exposed grease could ignite.

OVEN COOKING

Use caution when opening the oven door(s). Allow hot air or steam to escape before placing or removing food.

DO NOT heat sealed food containers. Pressure can build and cause them to burst, resulting in injury.

ALWAYS keep oven vent ducts clear and unobstructed.

OVEN RACK PLACEMENT

Ranges include two commercial-grade telescoping (sliding) racks, mounted on guides along the oven walls. The PRD48 small oven also includes two telescoping racks.

To install racks, align them between the top and bottom guides in any of the five rack positions. Pull the rack out fully, then lift up and out of the sliding mechanism to remove.

Use caution when handling sliding racks, as edges may be sharp.

ALWAYS install racks in your desired position before preheating the oven.

When adjusting racks while the oven is hot, avoid touching heating elements with potholders or oven mitts.

PRD30, PRD36 and PRD48 large oven racks support at least 25 lb (11 kg). PRD48 small oven racks support at least 15 lb (7 kg).

⚠ WARNING: Use caution when placing heavier food loads on racks exceeding these weights to avoid risk of injury or damage to the range.

HEATING ELEMENT AND DOOR SAFETY

⚠ WARNING: DO NOT clean the door gasket. The gasket is crucial for sealing the oven properly. Avoid rubbing, damaging, or moving it.

Avoid abrasive oven cleaners. NEVER use commercial oven cleaners or protective liners inside or around the oven. Clean only the parts specified in the manual. ALWAYS remove oven racks before cleaning them separately.

DO NOT touch heating elements or the oven interior while in use or immediately after. Heating elements can be hot even if they look dark. Oven interior surfaces can cause burns.

If the power goes out, turn all oven and broiler controls to the OFF position and do not use the oven until power is restored.

During and after use, keep clothing and other flammable materials away from heating elements and hot oven surfaces until fully cooled.

Other areas like oven vents, doors, and glass windows may also get hot enough to cause burns — please be cautious.

ALWAYS double-check that all cooktop, oven, and broiler controls are turned OFF after cooking.

It's normal for moisture to appear between the oven door's double glass panels, especially when cooking moist foods. The oven is designed with vents between the glass panes, and any moisture will usually evaporate within 12 - 24 hours.

When using the oven for the first time, you may notice: An odor as manufacturing oils burn off — this is normal. Some noises as new parts settle and adjust during initial heating.

Basic Maintenance Instructions

REMOVING THE OVEN DOOR AND KICK PLATE

For everyday use, removing the oven door is not recommended. ALWAYS ensure the oven is off and completely cool before reinstalling the door.

⚠ NOTE: The steps shown use the PRD36 model as an example, but the process is the same for PRD30 and PRD48 models.

⚠ WARNING: Be careful when removing and lifting the oven door — it's quite heavy. Use a helper if needed. DO NOT lift the door by the handle or pull / move the range by the kick plate, as this may damage the range and void your warranty.

1. Open the oven door fully.

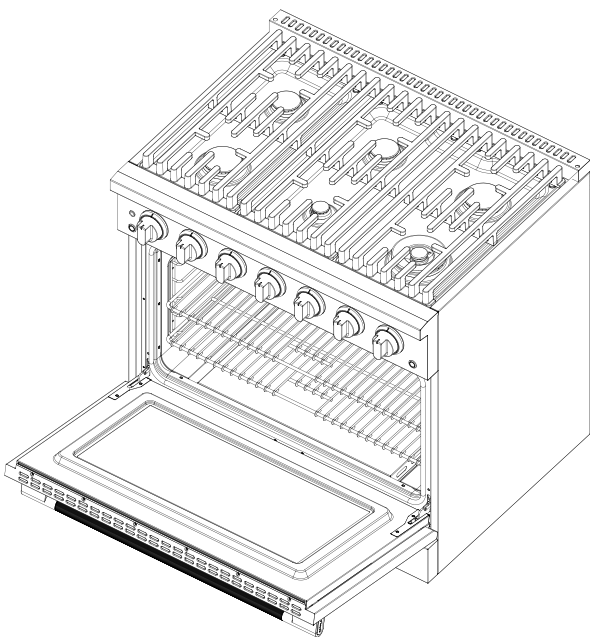

2. Lift and pull back the small levers on both hinges until they're fully unlocked.

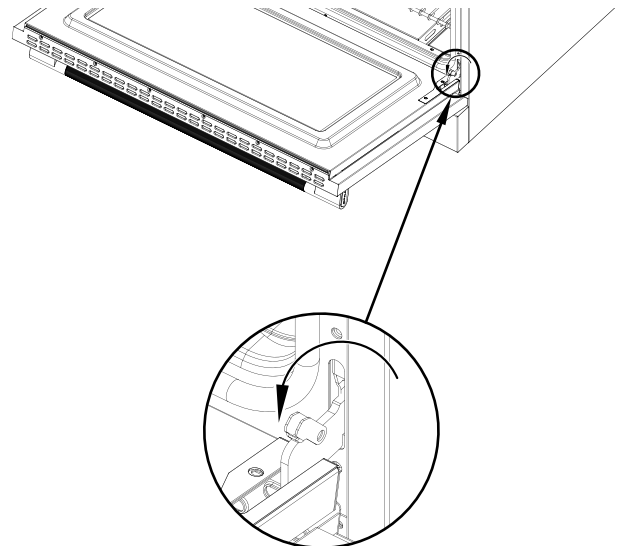

3. Gently swing the oven door toward the closed position until the unlocked levers touch the oven frame. The door should stop about 4" (102 mm) from fully closing.

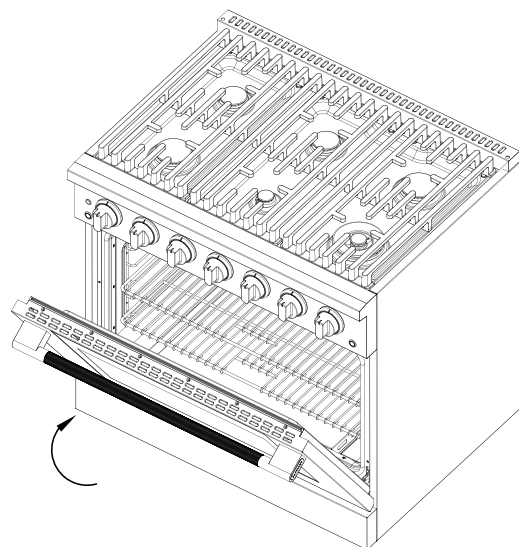

HAUSLANE

4. Lift the door up and pull it toward you to release it from the hinge receivers (see image). It should detach easily. If not, double-check that the levers are unlocked—DO NOT force it. To reinstall, reverse **steps 1-4**.

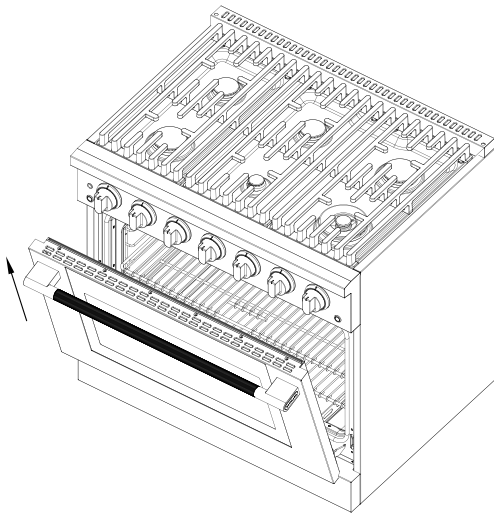

5. Remove the kick plate by unscrewing the screws, lift up and pull the kick plate out of the side holes. To reinstall the kick plate, align it with the holes and reinsert the same screws.

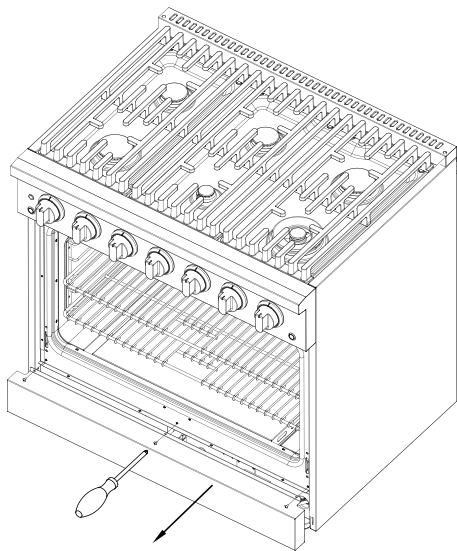

REPLACING THE OVEN LIGHTS

⚠ WARNING: To avoid electrical shock or injury, ensure the oven and light bulbs are completely cool, and the oven power is turned off before replacing any bulbs.

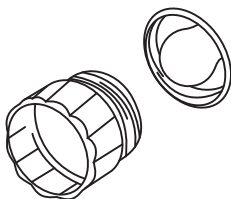

The PRD30, PRD36, and PRD48 large ovens each have two type E14 (120V, 25W) halogen light bulbs located at the upper left and right corners inside the oven. To replace, unscrew the protective cap inside the oven that covers the bulb. The PRD48 small oven has one light bulb.

⚠ NOTE: Avoid touching the bulbs with your bare fingers as oils can cause them to burn out prematurely. Use protective gloves or a clean cloth when handling the bulbs.

CLEANING YOUR RANGE

⚠ WARNING: DO NOT start cleaning until all burners are off and the oven is completely cool. We also recommend disconnecting power before cleaning to reduce the risk of electric shock.

⚠ IMPORTANT: NEVER use abrasive cleaners — they can permanently scratch stainless steel surfaces. Avoid using bleach or alcohol wipes on stainless steel. ALWAYS follow the cleaning product's label instructions.

CONTROL KNOBS

For routine cleaning, wipe knobs with a damp cloth and mild soap. For greasy buildup, use a nonabrasive liquid detergent on a damp cloth.

Avoid rotating the knobs during cleaning, as this could release gas.

To clean stubborn stains, gently pull knobs straight off. Clean and dry thoroughly, then reinstall on the same valve. ALWAYS ensure knobs are fully dry before using the range.

BURNER GRATES

ONLY use cast iron grates in their correct positions. DO NOT operate a burner without cookware on the grate for extended periods.

Let grates cool completely before cleaning. Use hot water or white vinegar. DO NOT place grates in the dishwasher.

Ensure grates are securely positioned when reinstalling.

Grates have rubber pads on the feet to prevent scratching the cooktop. After cleaning, confirm the pads are intact. If needed, reattach them with heat-resistant adhesive.

ENAMELED CAST IRON GRIDDLE (PRD48 MODEL ONLY)

Let the griddle cool completely, then clean with hot water or white vinegar. DO NOT place in dishwasher.

Unlike traditional cast iron, this enameled griddle DOES NOT require regular seasoning (e.g., oiling and baking at high heat).

BURNER CAPS

Once cool, wash caps in hot, soapy water and rinse well. To remove stuck-on food, use a plastic scouring pad. Dry thoroughly before replacing.

DO NOT use stainless steel cleaners on these caps—they are not made of stainless steel.

BURNER SPREADS

Remove ONLY when fully cool. Wash in hot, soapy water, rinse, and use a soft brush to clean debris between the slots.

Clean the burner slots regularly with a small wire or needle, especially after spills that may clog the holes.

Burner spreads and caps are not dishwasher safe.

STAINLESS STEEL

Clean the stainless steel surface with warm sudsy water or stainless steel polish. Wipe with the grain. ALWAYS follow product label instructions.

DO NOT use steel wool, harsh cleaners, or anything containing chlorides or chlorine. These can scratch or damage the finish.

Wipe away soap with a damp cloth, then dry with a soft, clean towel.

DOOR HANDLE

Clean with warm soapy water and dry with a soft, lint-free cloth.

DO NOT use abrasive cleaners or scrubbers, as they can permanently damage the finish.

OVEN GLASS

Wipe glass surfaces with warm soapy water. For fingerprints or smudges, use a mild glass cleaner. Dry with a soft, lint-free cloth.

PORCELAIN SURFACES

Clean the cooktop, oven interior, drip pan, and door liners with warm soapy water. Rinse and dry with a soft cloth.

Avoid using abrasive powders or liquids. DO NOT leave acidic or alkaline substances—such as vinegar, lemon juice, salt, or tomato sauce—on these surfaces.

Use a rubber spatula to gently remove stuck-on food or residue.

OVEN RACKS

Clean with warm soapy water. For heavier soil, use a non-abrasive scouring pad like steel wool and plenty of water.

OVEN FRAME

Clean with hot water and soap-filled steel wool pads or kitchen-safe cleaners. Rinse well and dry.

DO NOT clean the gasket. The fiberglass gasket cannot tolerate abrasion and must remain intact.

OVEN DOOR

Clean all door surfaces with soapy water. Use glass cleaner on the exterior glass.

DO NOT use oven cleaners, powders, or abrasives.

Avoid getting water into any door slots or holes, as leftover soap may cause stains when heated.

⚠ WARNING: DO NOT leave acidic fluids such as tomato sauce or lemon juice on the cooktop or oven interior for long periods, as this may cause etching and permanent damage. This type of damage is not covered under the manufacturer's warranty.

For the replacement parts list, please visit www.Hauslane.com or contact us at **1-800-929-0168**, or email info@hauslane.com.

Troubleshooting Tips

⚠ WARNING: If a problem cannot be resolved after following the instructions in the manuals, please contact Hauslane at **1-800-929-0168** or email at **info@hauslane.com**. Never attempt to repair or disassemble gas lines, burner spreads, or the internal electrical wiring of your range.

PROBLEM	POSSIBLE CAUSE	SOLUTION
No ignition spark.	Ignition module failure	Use manual lighting: hold a lit match near the flame spreader, push in the control knob, and turn it counterclockwise to HI. Adjust heat once lit. Contact customer service if problem persists.
Igniters spark continuously after flame ignition.	Power supply polarity reversed	Contact Hauslane customer service.
	Igniters are wet or dirty.	Dry or clean igniters thoroughly.
Burners will not light.	Burner parts or igniters wet, dirty, or misaligned	Check that the burner parts are clean, dry, and correctly assembled.
	Spark tip igniters damaged or dirty	Check that the igniters are clean and not damaged.
Igniters are sparking but burners are not igniting.	Gas shut-off valve is in the "OFF" position.	Turn shut-off valve to the "ON" position.
Cooktop burners will not stay lit and auto reignition is not working.	Spark tip or igniter failure.	Contact Hauslane customer service.
The flames have suddenly gone out.	A draft or spill has extinguished the flame.	Turn burners off, clean burners and cooktop area, then reignite the burners once clean.
Burner flame goes out at low setting	Low gas pressure.	Contact gas company.
	Air intake holes around burners obstructed	Remove obstructions from the air intake holes.
	Low flame adjustment may be set too low.	Readjust the flame setting.
Top burners do not light or do not burn evenly.	Plug not fully inserted in electrical outlet	Ensure the unit is properly connected to the power supply.
	Burner holes on burner clogged	Remove burner heads and clean. Check electrode area for food or grease buildup and clean thoroughly.
Burner flames are very large and yellow.	Burner spread ports are clogged	Clean burner spread ports using a straightened paperclip, needle, or wire.
	Burner spreads or caps not properly positioned	Remove and carefully reinstall burner spreads and caps correctly.
	Appliance operating with wrong type of gas	Ensure appliance gas type matches the gas supply.
	Regulator missing, faulty, or set for wrong gas	Have a qualified technician replace or adjust the regulator appropriately.

Troubleshooting Tips

PROBLEM	POSSIBLE CAUSE	SOLUTION
Brass burners change color	Brass burners naturally develop a patina over time. This deep, rich color forms through oxidation and helps protect the burners from corrosion. It is a normal part of the material's aging process and does not affect performance. This is not considered a defect and does not require return or replacement.	This is a normal occurrence for brass burners; no troubleshooting is required.
"Cracking" or "popping" sound is heard coming from appliance.	Metal heating and cooling sounds	Normal operation noise for ovens; no action required.
Steam or condensation from oven vent	Cooking foods high in moisture or cold ambient temperature	Condensate is natural and non-corrosive; no action required.
Nothing works (no power)	Power supply not energized	Have an electrician inspect power supply, circuit breaker, wiring, and fuses.
Oven will not heat	Oven settings incorrect	Adjust temperature setting or change oven rack position.
Foods overcooked or undercooked	Incorrect cooking temperature	Dry or clean igniters; if problem persists, contact Hauslane customer service.

Still experiencing problems after following these steps?

Contact a technician to assist. Contact us at **1-800-929-0168** or **info@hauslane.com**.



Extended Warranties

If you are interested in an extended warranty, sign up on our website at www.hauslane.com



Parts and Accessories

If you need replacement parts or accessories, visit www.hauslane.com



Contact Us

We'd be happy to answer your questions or resolve any issues you may have.

Phone: **1-800-929-0168**

Email: info@hauslane.com



Find Us and Connect with Us
@HauslaneOfficial

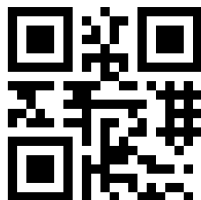

HAUSLANE

HEADQUARTER

222 Harris Ct.
South San Francisco,
CA 94080
United States

EMAIL

info@hauslane.com

CONTACT US

1-800-929-0168

WEBSITE

www.hauslane.com

SOCIAL MEDIA

@HauslaneOfficial
