

# SKU: LI009101

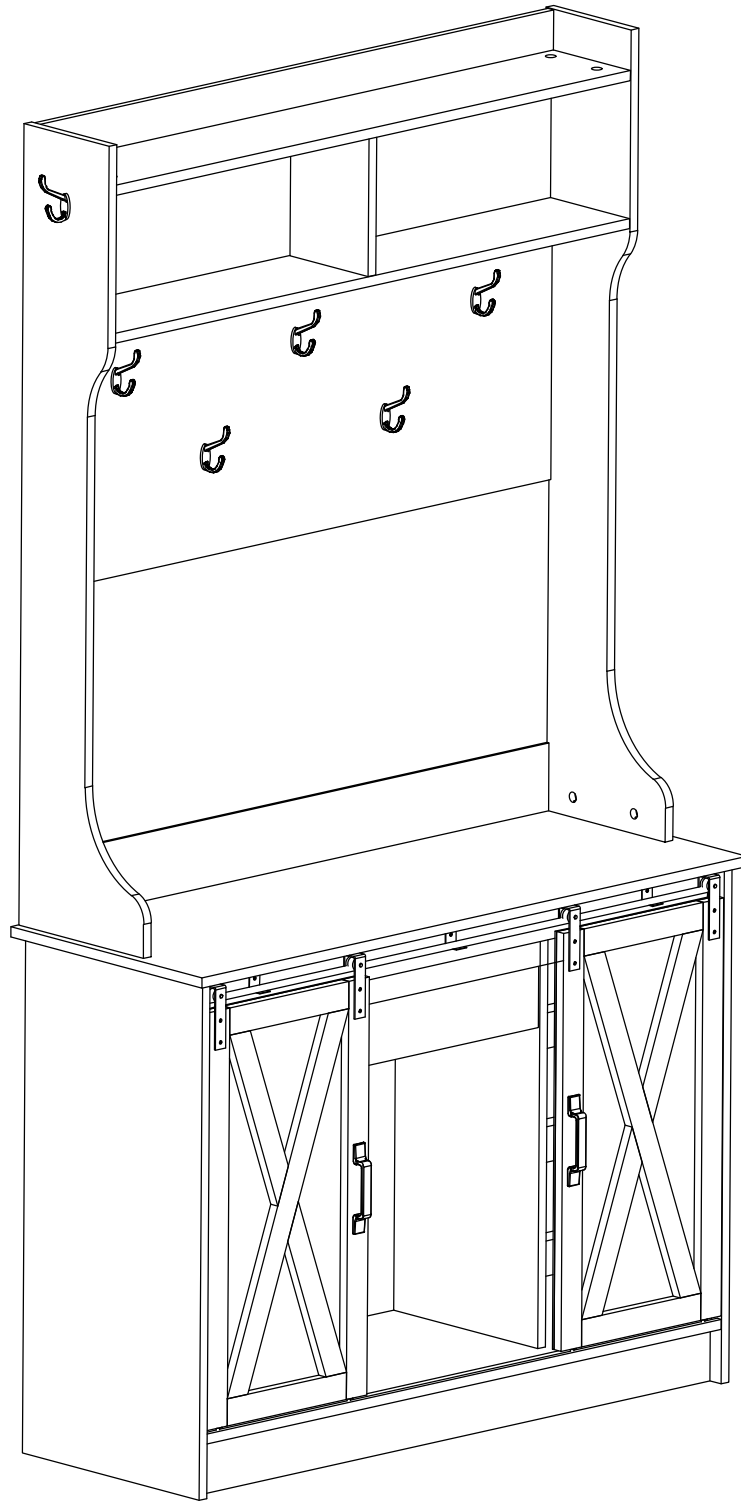

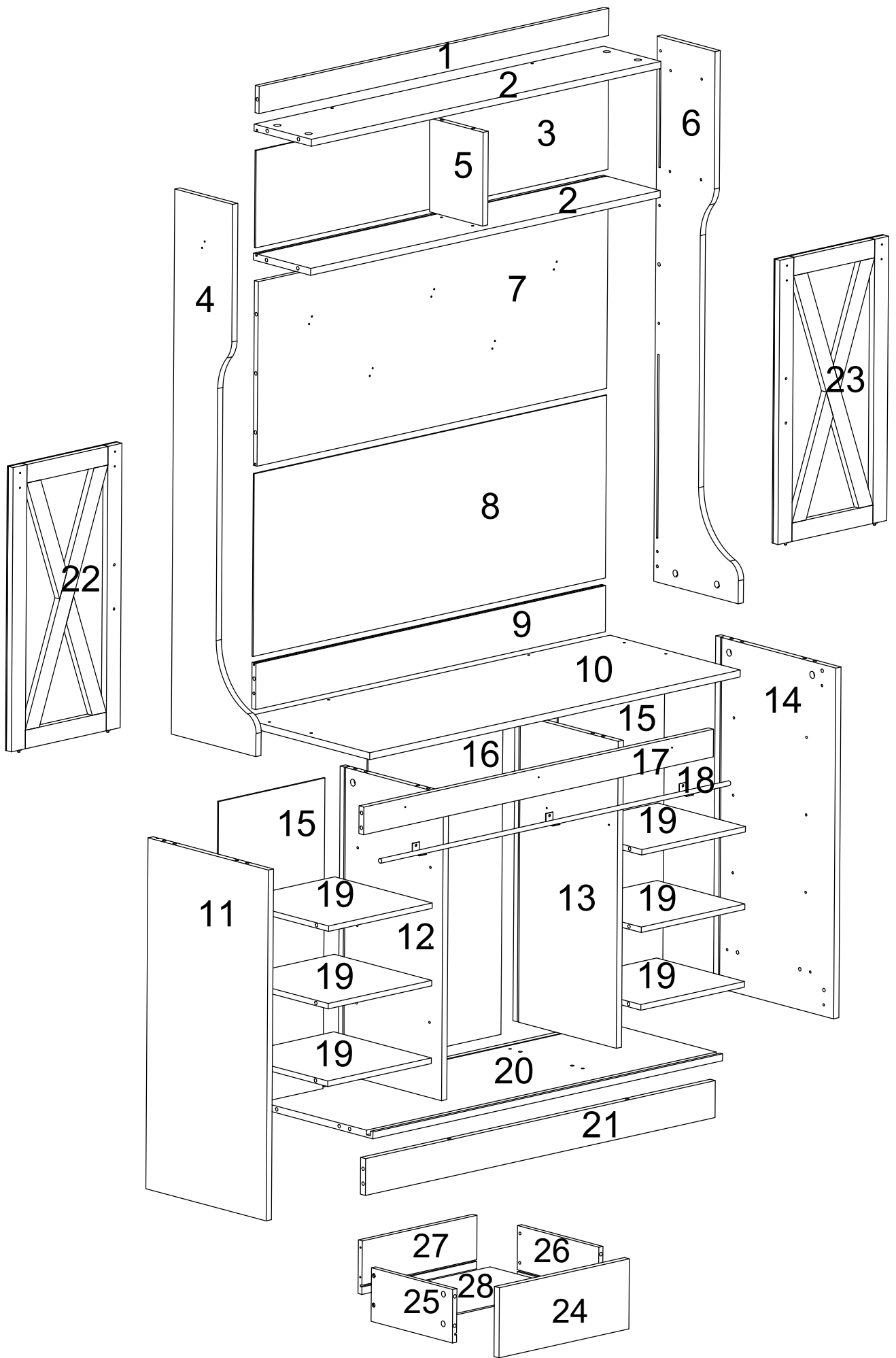

# Trouble Shooting

Missing/Damaged pieces/  
Wrong size and installation issues



Contact us with your problem, pic,  
number and qty to the "Contact seller"  
button in the detail page of your order



Respond with 24 hours to solve issue

# Before You Start

1. Read through each step carefully and follow the proper order
2. Separate and count all your parts and hardware
3. Give yourself enough room for the assembly process
4. Caution: If using a power drill or power screwdriver for screwing, please be aware to slow down and stop when screw is tight. Failure to do so may result in stripping the screw

# Cam Lock Fastening System

This Cam Lock Fastening System will be used throughout the assembly process

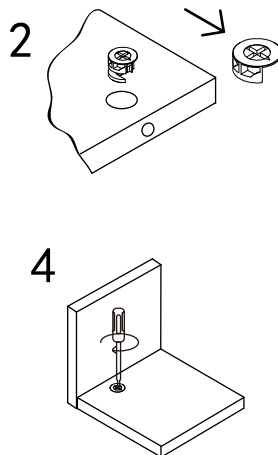
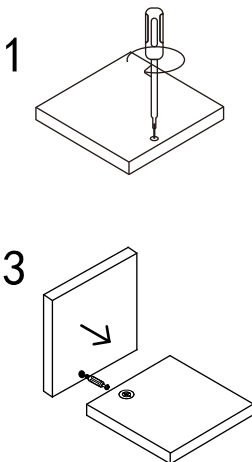

# Parts List

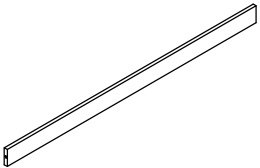
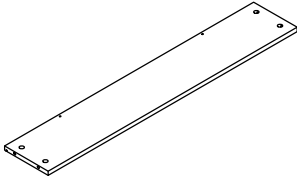
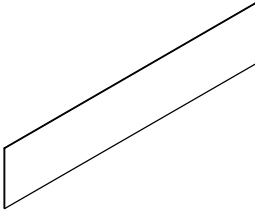
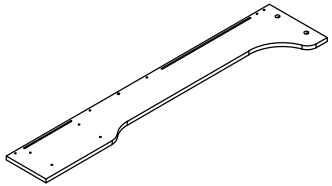
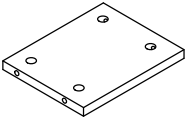
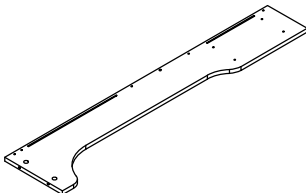
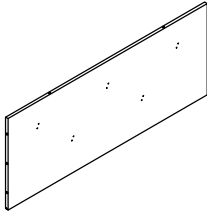
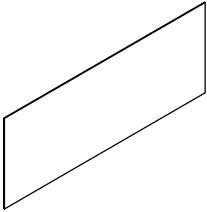
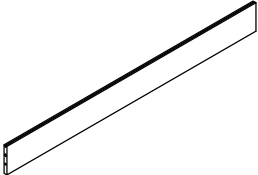
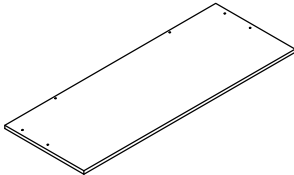
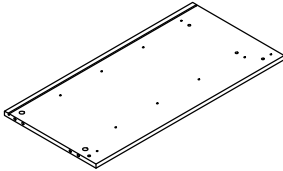
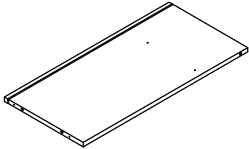
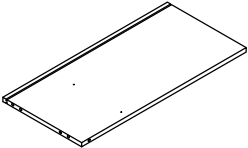
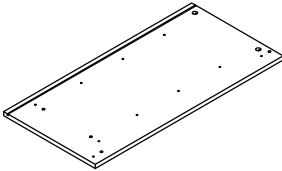
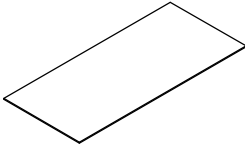
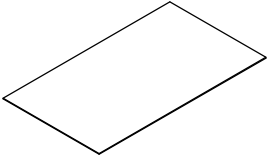
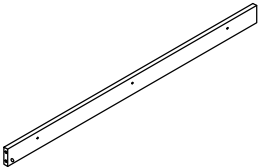
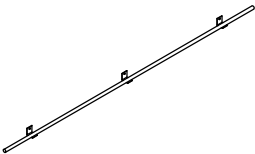
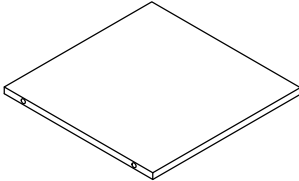
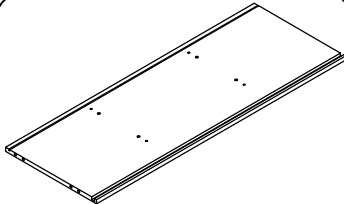
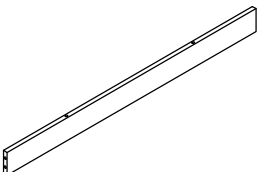
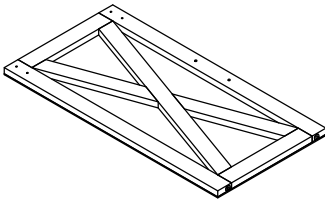
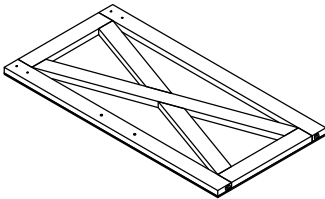
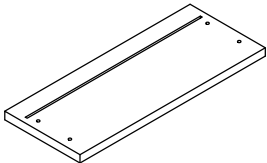
							
1	1PC	2	2PC	3	1PC	4	1PC
							
5	1PC	6	1PC	7	1PC	8	1PC
							
9	1PC	10	1PC	11	1PC	12	1PC
							
13	1PC	14	1PC	15	2PC	16	1PC
							
17	1PC	18	1PC	19	6PC	20	1PC
							
21	1PC	22	1PC	23	1PC	24	1PC

# Parts List

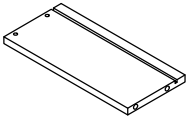

25

1PC

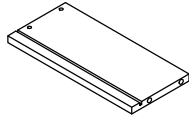

26

1PC

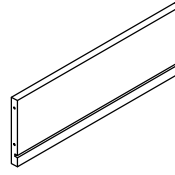

27

1PC

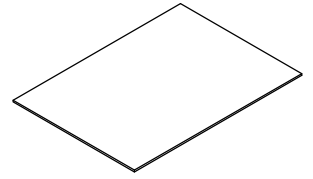

28

1PC

# Hardware List

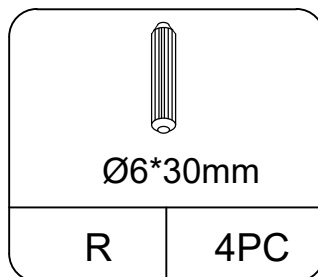
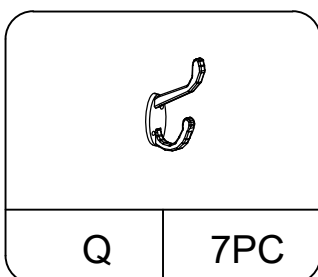
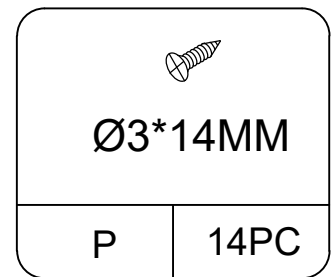
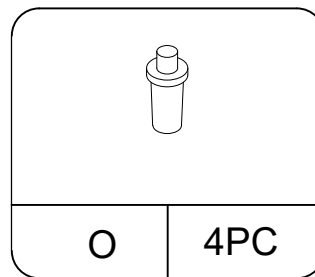
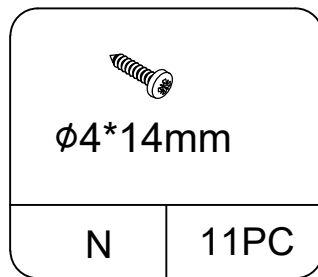
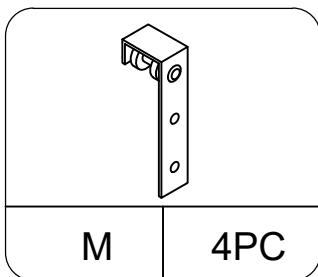
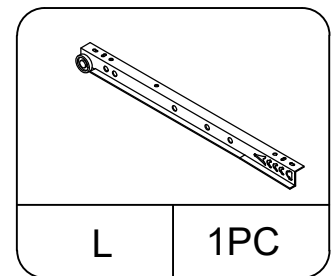
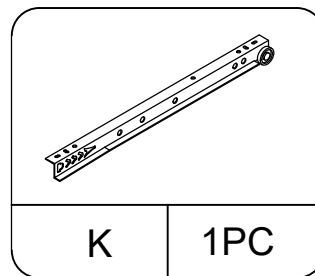
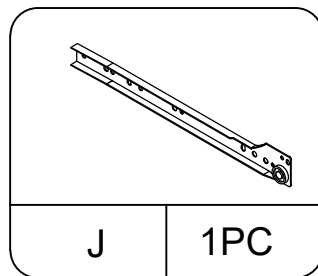
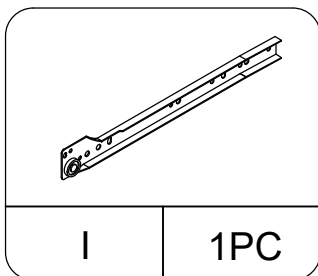
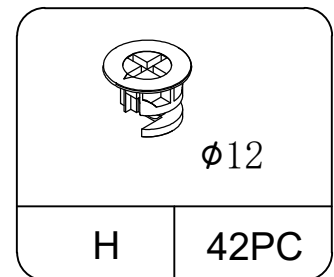
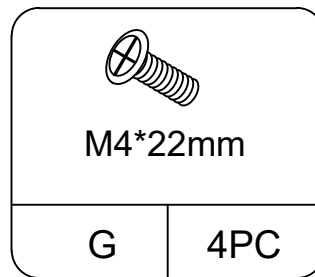
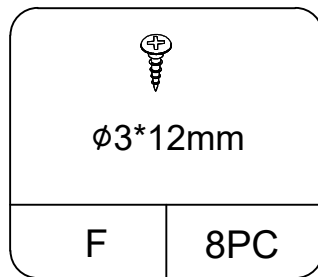
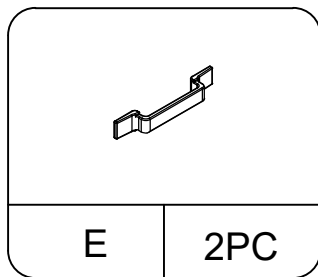
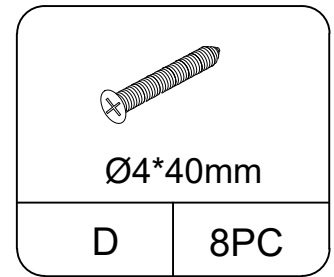
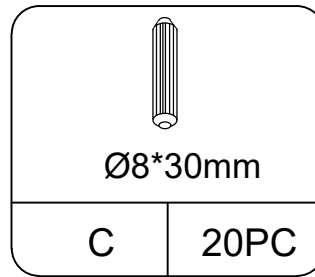
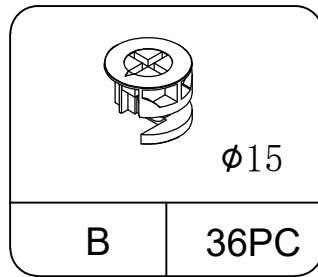
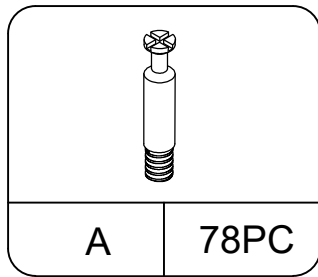

Note: Don't tighten all screws during installation  
 Check all the components & screws before assembly.  
 Do not install in case part is missing, contact us to get.  
 Contact us with your problem to "Contact seller" button in the detail page of your order  
 We will respond within 24 hours

# STEP 1

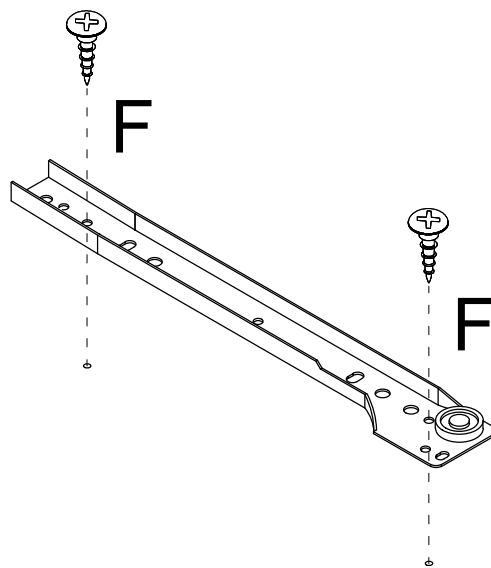
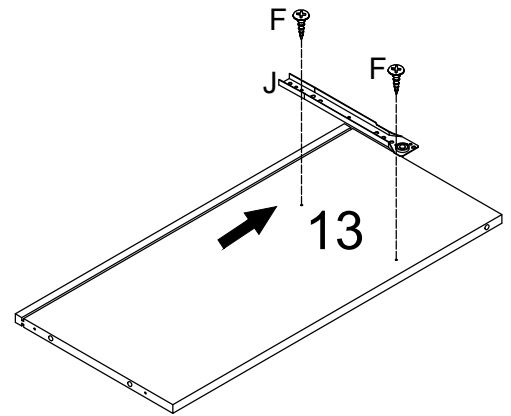
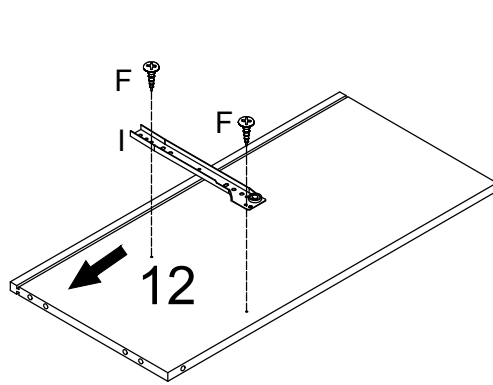
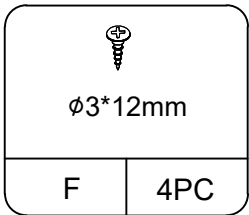
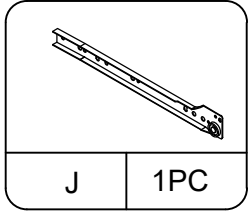
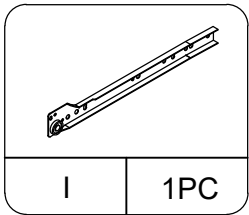

# STEP 2

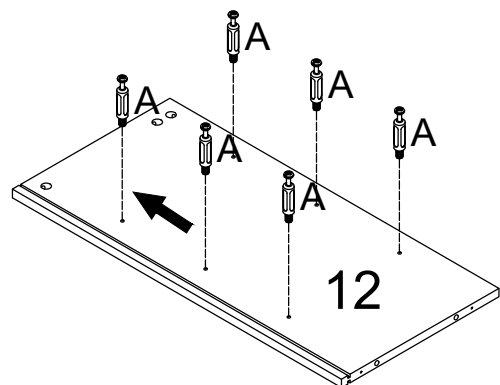
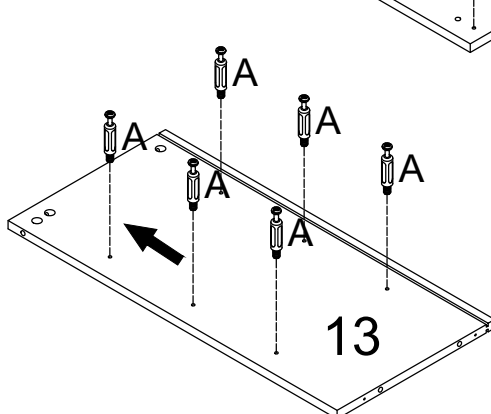
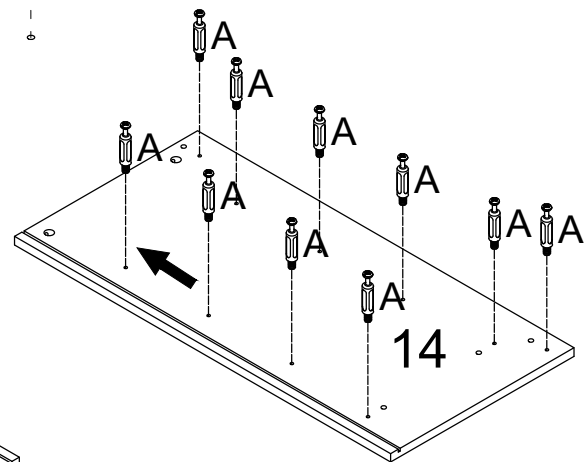
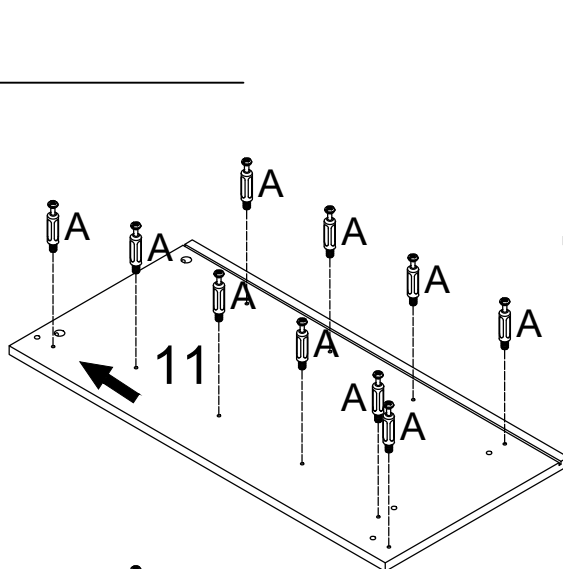
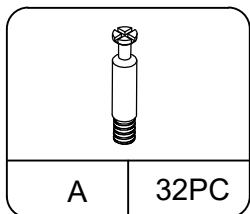

# STEP 3

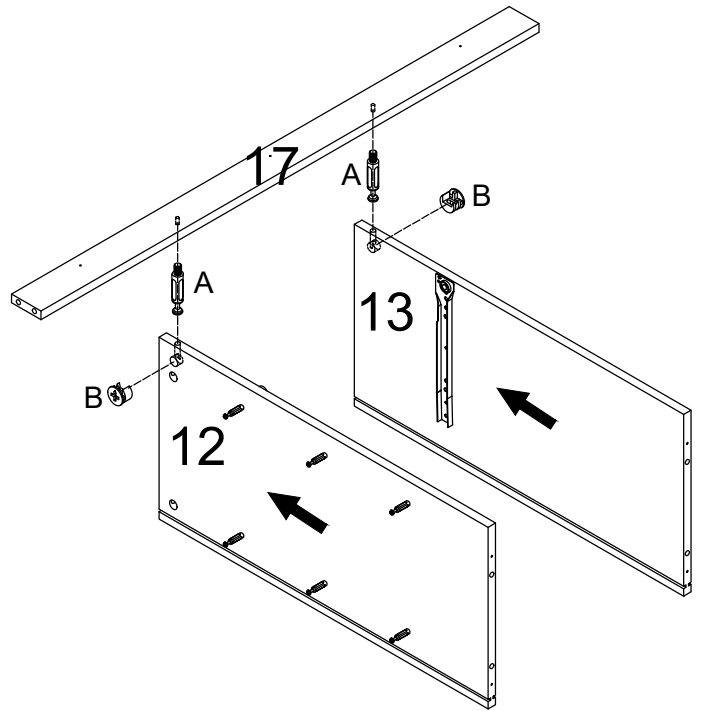
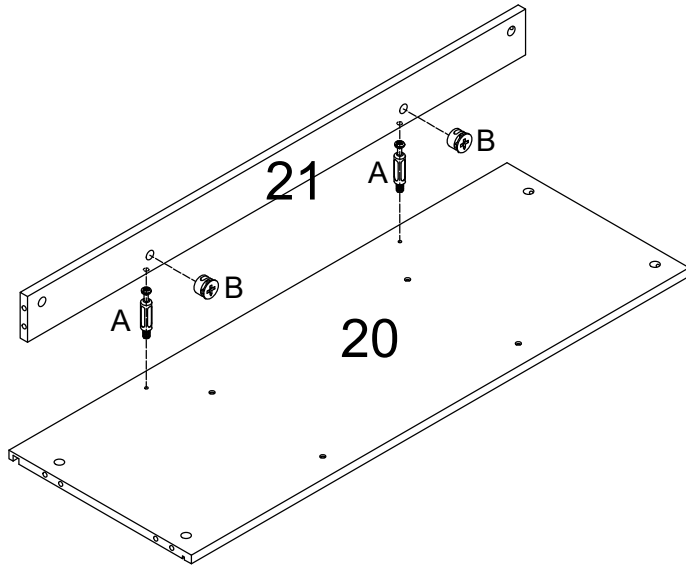
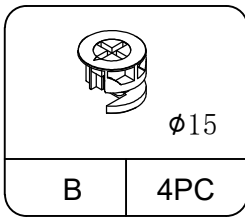
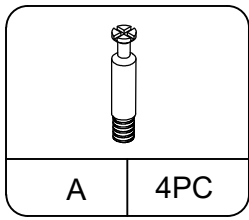

# STEP 4

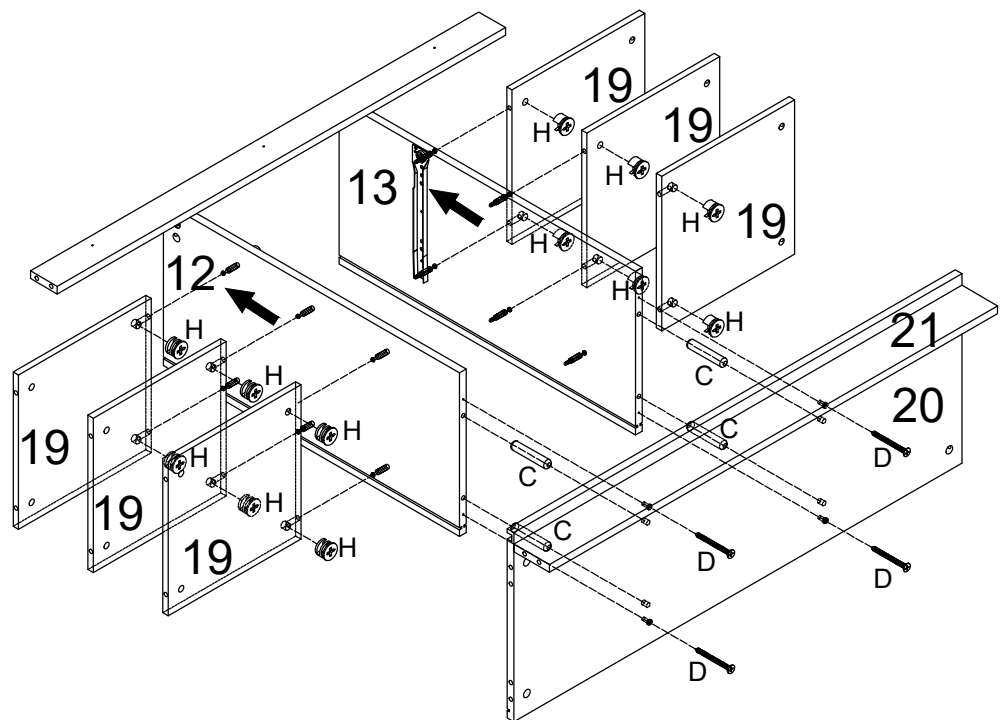
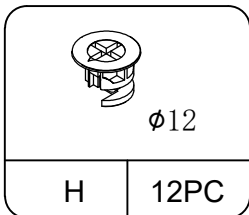
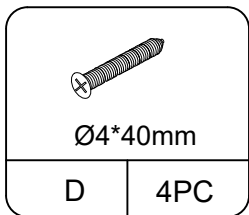
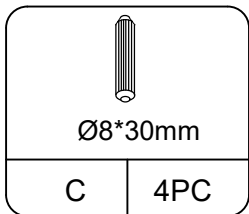

# STEP 5



**Important**  
 2 people required  
 2 personnes requises  
 2 personas requeridas

φ15

B	8PC
---	-----

Ø8\*30mm

C	8PC
---	-----

φ12

H	12PC
---	------

φ4\*14mm

N	3PC
---	-----

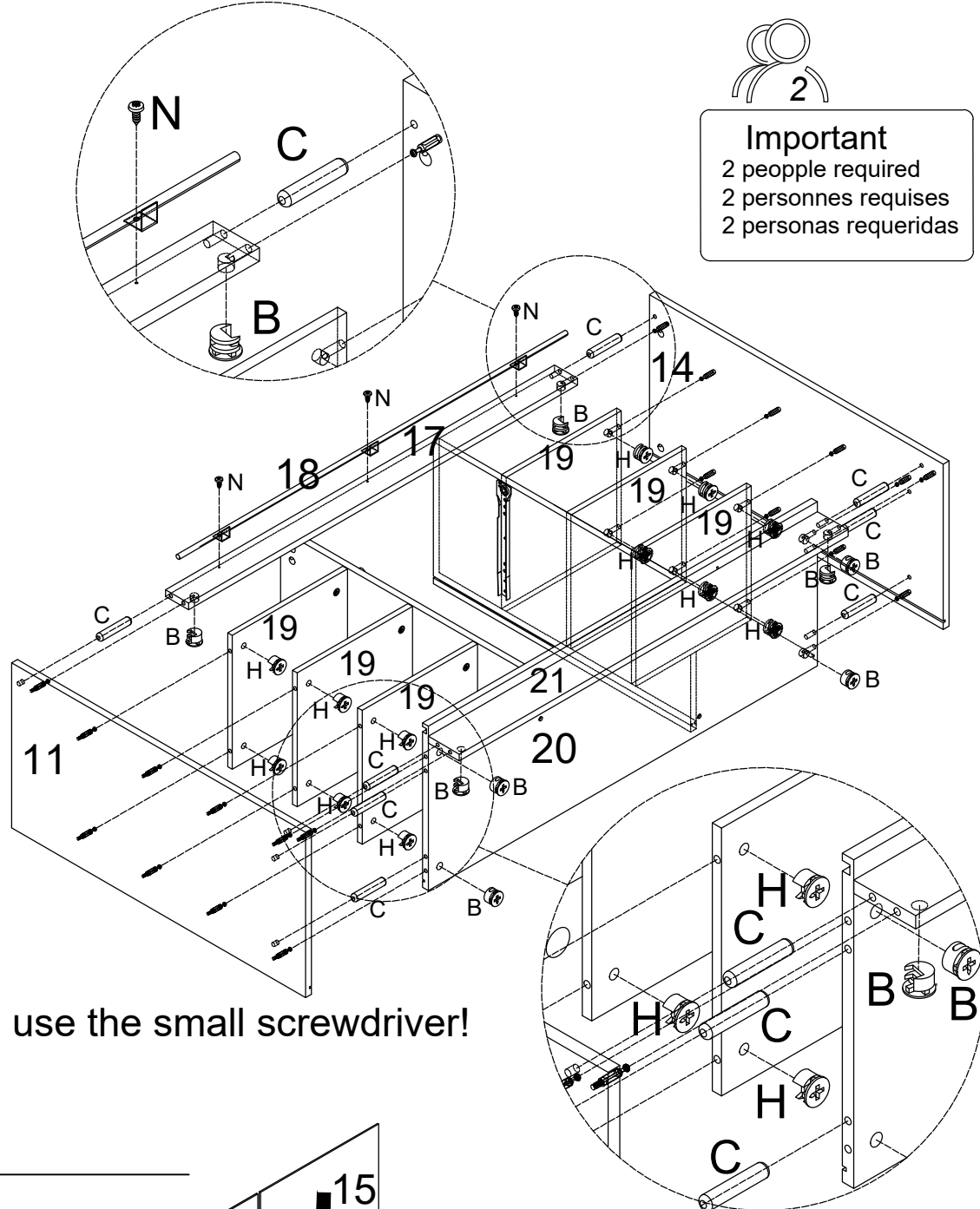

please use the small screwdriver!

# STEP 6

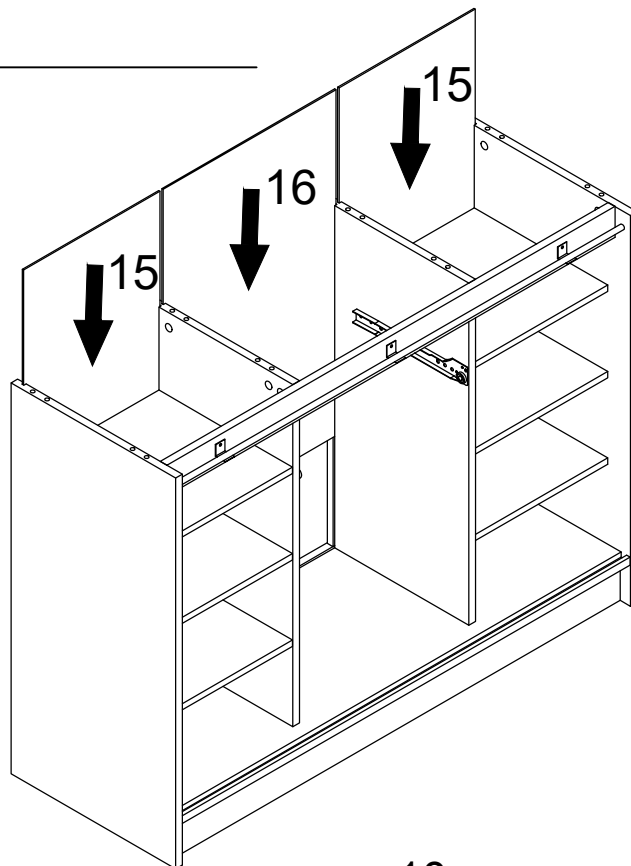

# STEP 7

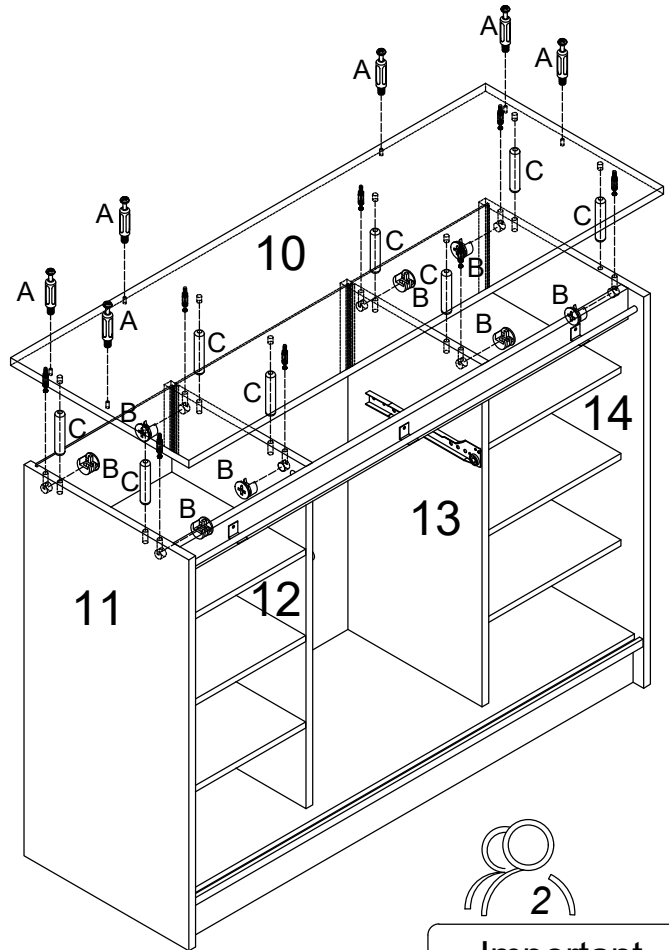
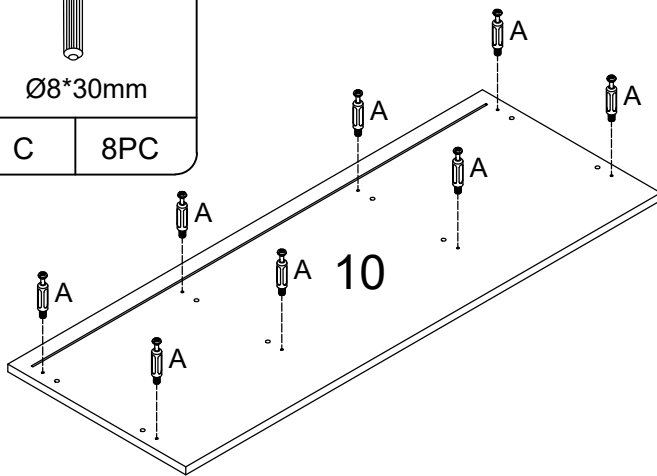
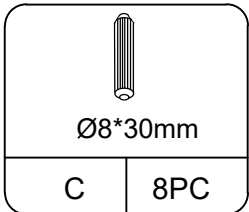
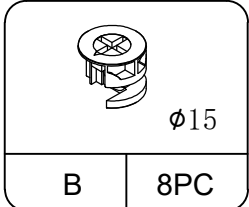
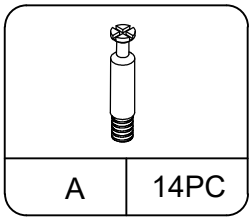

**Important**  
2 people required  
2 personnes requises  
2 personas requeridas

# STEP 8

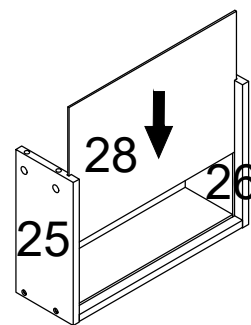
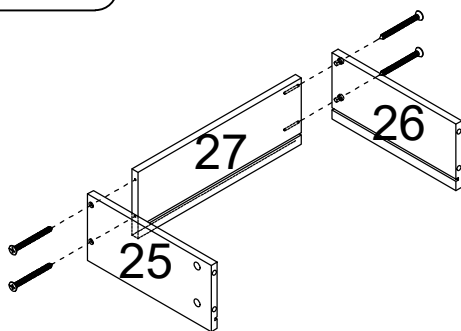
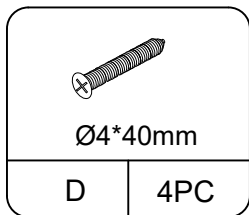

# STEP 9

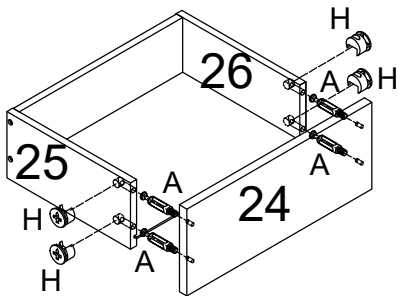
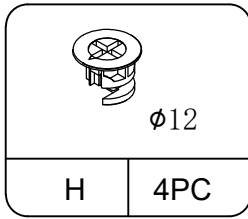
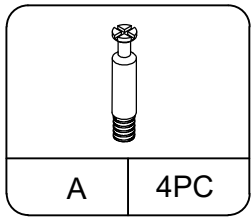

# STEP 10

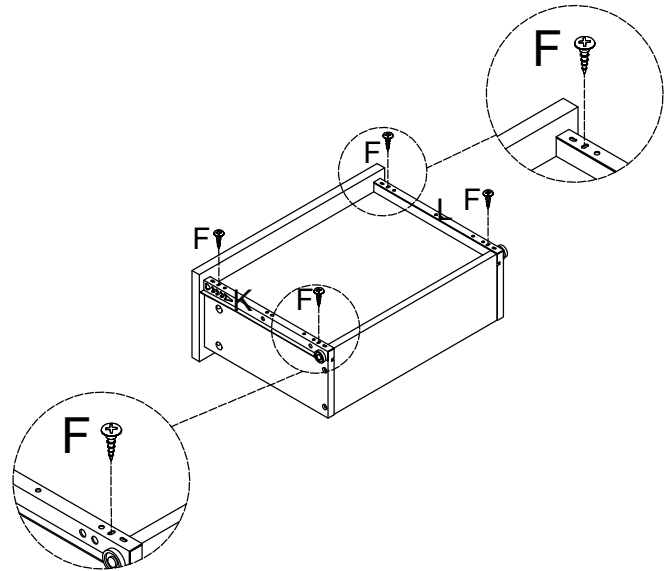
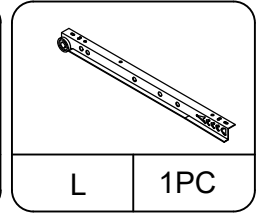
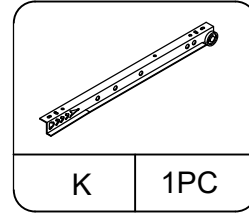
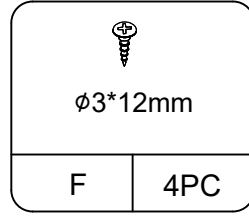

# STEP 11

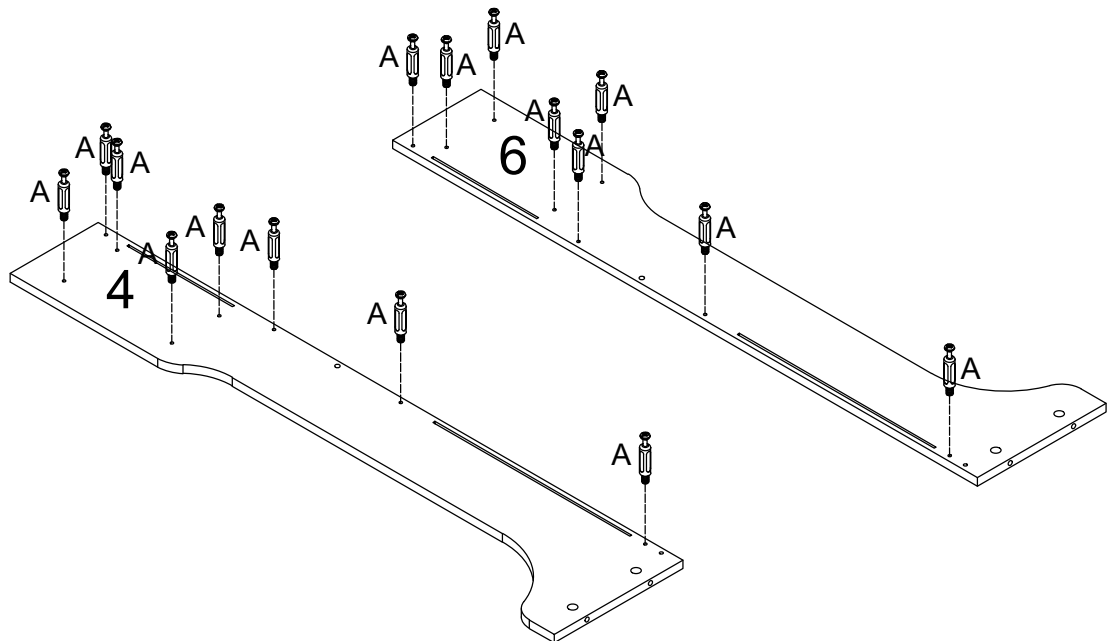
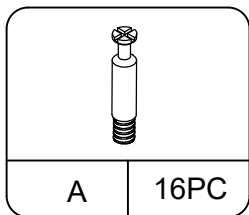

# STEP 12

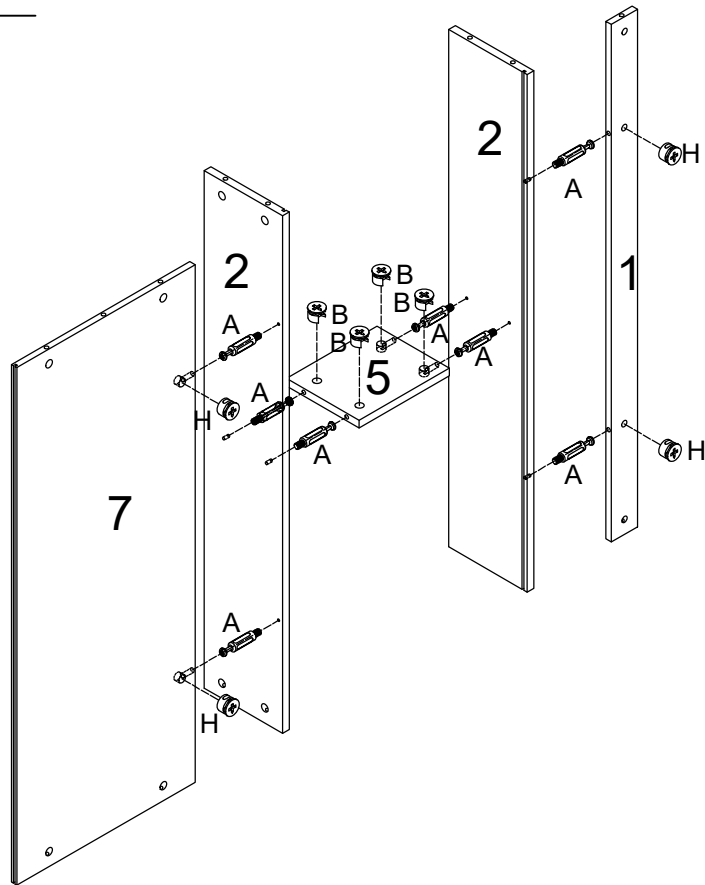
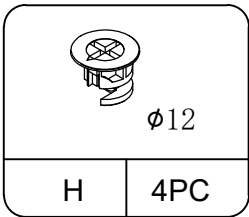
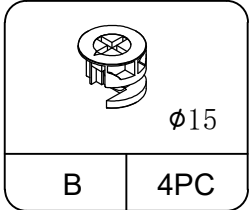
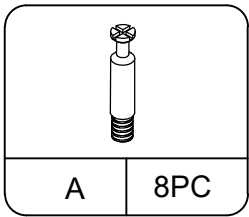

# STEP 13

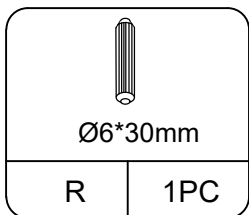
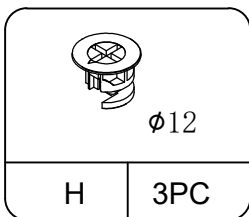
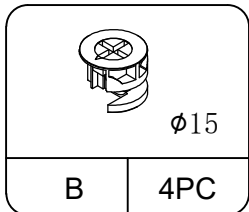

**Important**  
 2 people required  
 2 personnes requises  
 2 personas requeridas

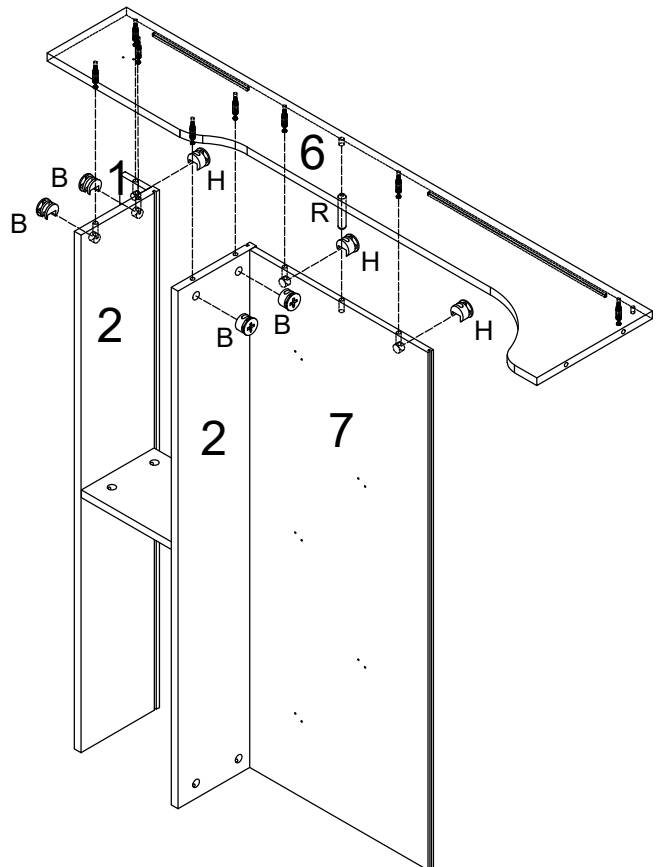

# STEP 14

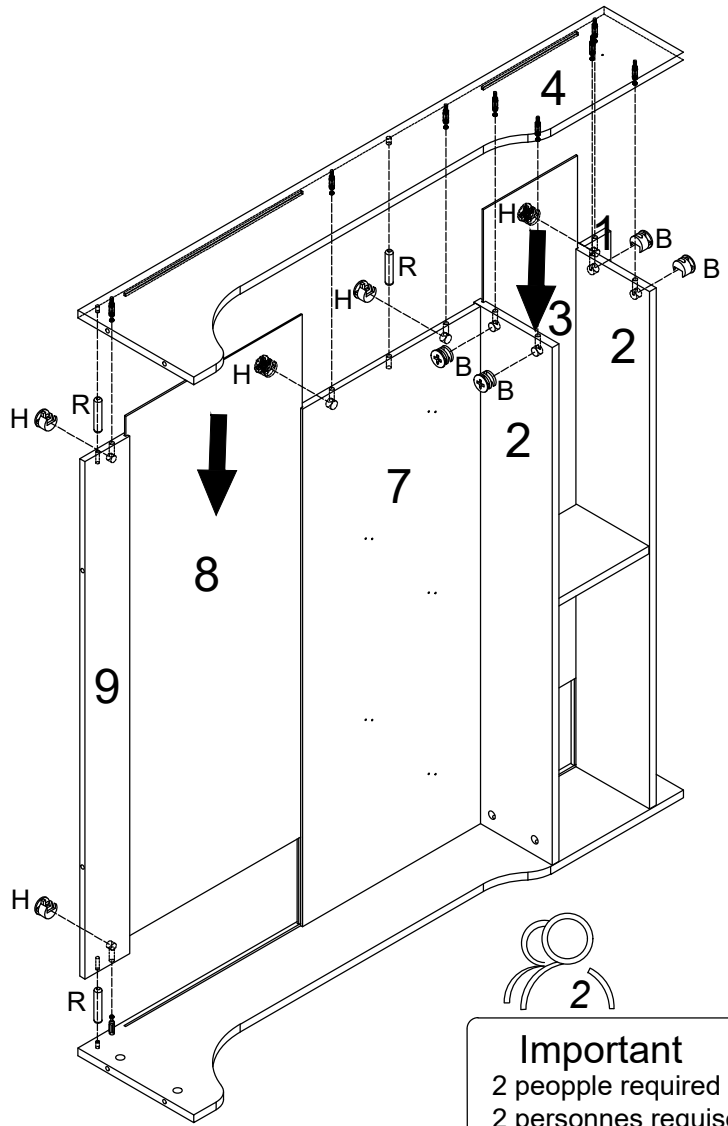
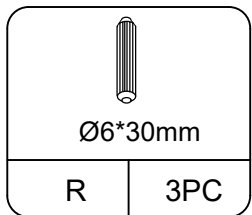
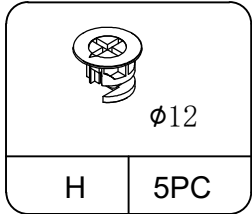
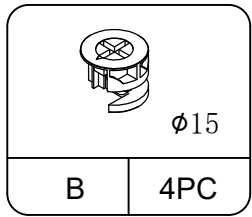

**Important**  
 2 people required  
 2 personnes requises  
 2 personas requeridas

# STEP 15

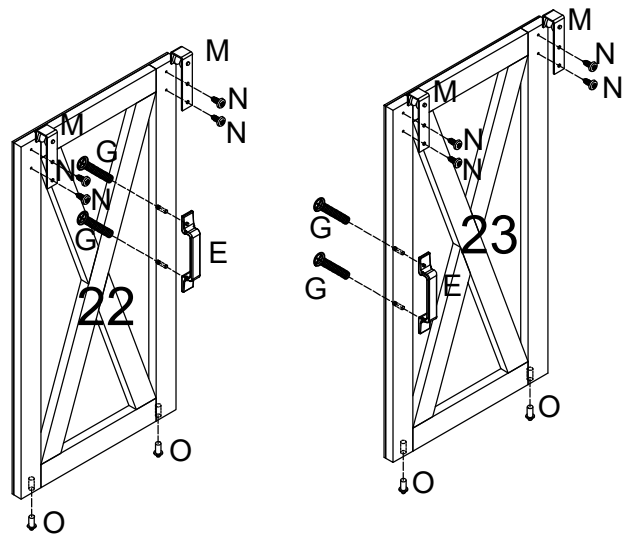
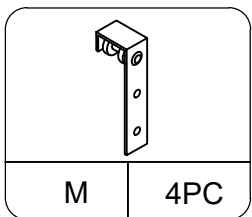
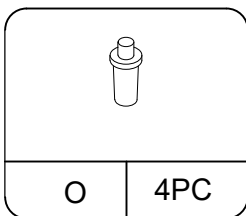
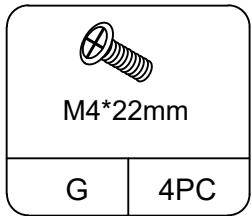
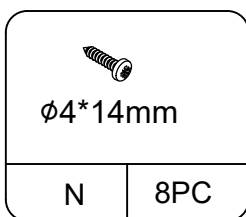
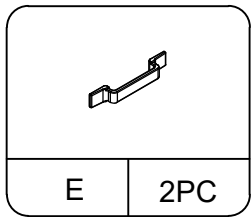

# STEP 16

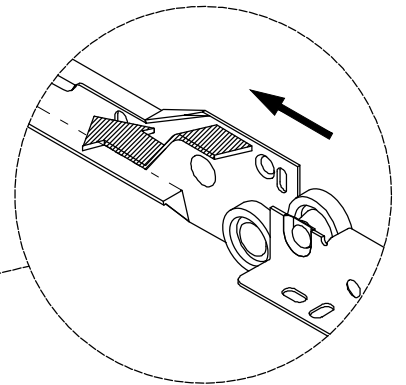
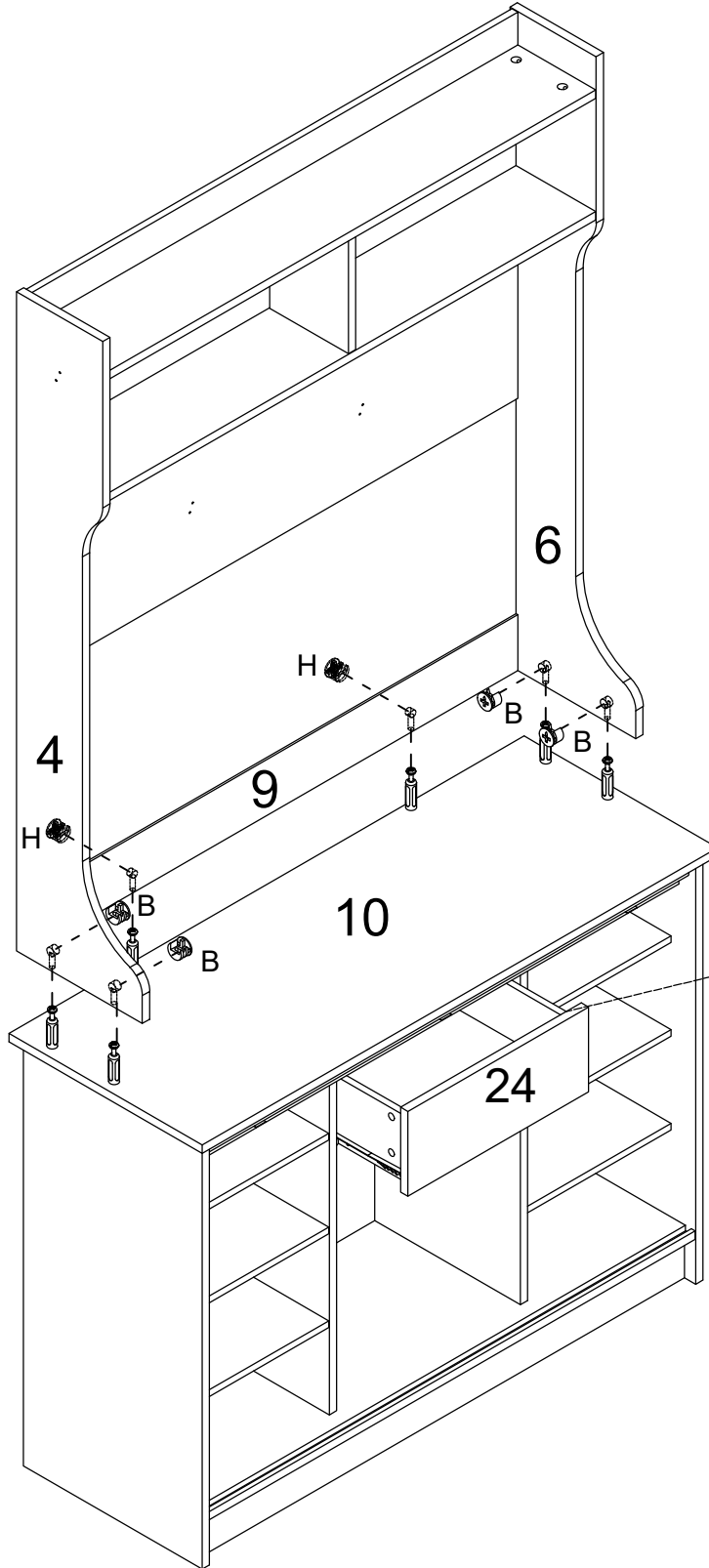
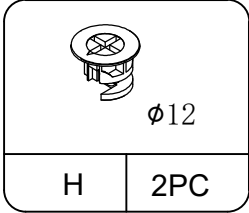
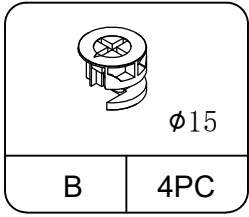

**Important**  
2 people required  
2 personnes requises  
2 personas requeridas

# STEP 17



Ø3\*14MM

P

14PC



Q

7PC

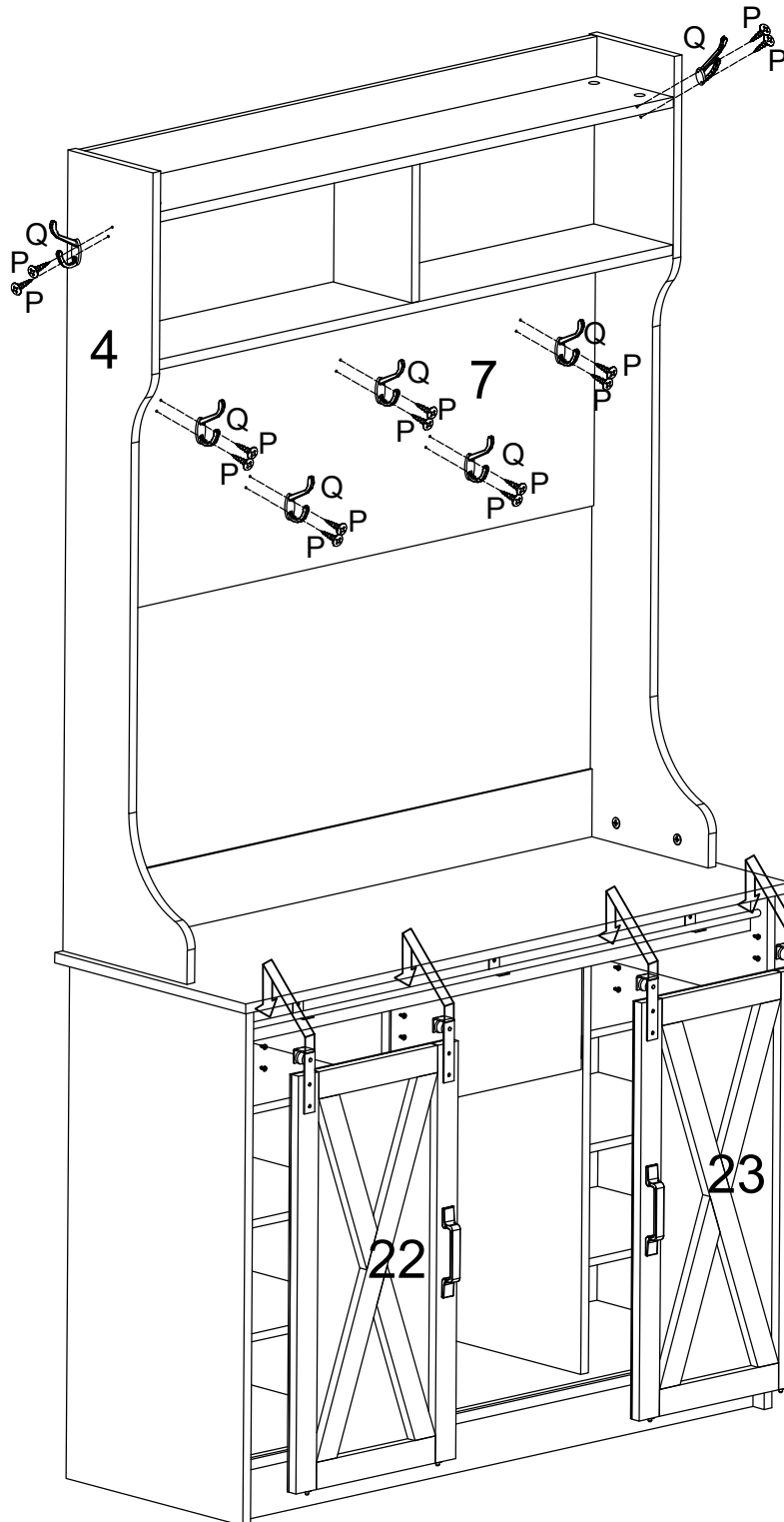

Please Make sure every  
screw is locked