

---

# ASSEMBLY INSTRUCTIONS

## COFFEE TABLE

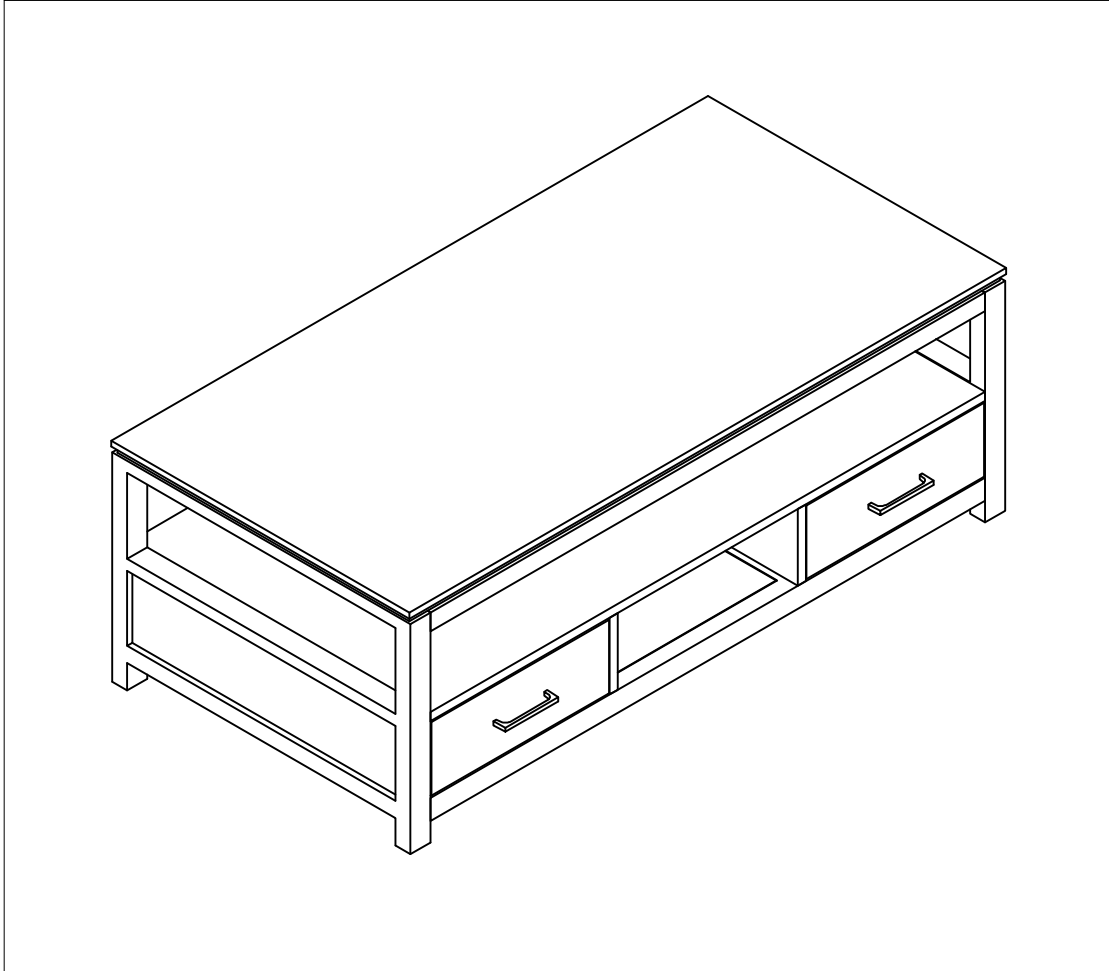

### **We are here to help!**

We do our best to insure that your furniture arrives in excellent condition. In the event that a part is damaged or missing, we will be happy to provide you with replacement parts, at no charge, within 30 days of purchase, providing the parts are available in our warehouse and the item purchased is part of our current inventory. In order to receive spare parts, at no charge, you must provide proof of purchase within 30 days.

If you need assistance with assembly or replacement parts, please call our Customer Service, prior to returning the item to the store.

Or visit our web site to order spare parts and for care instructions on your newly purchased furniture.

# PARTS IDENTIFICATION

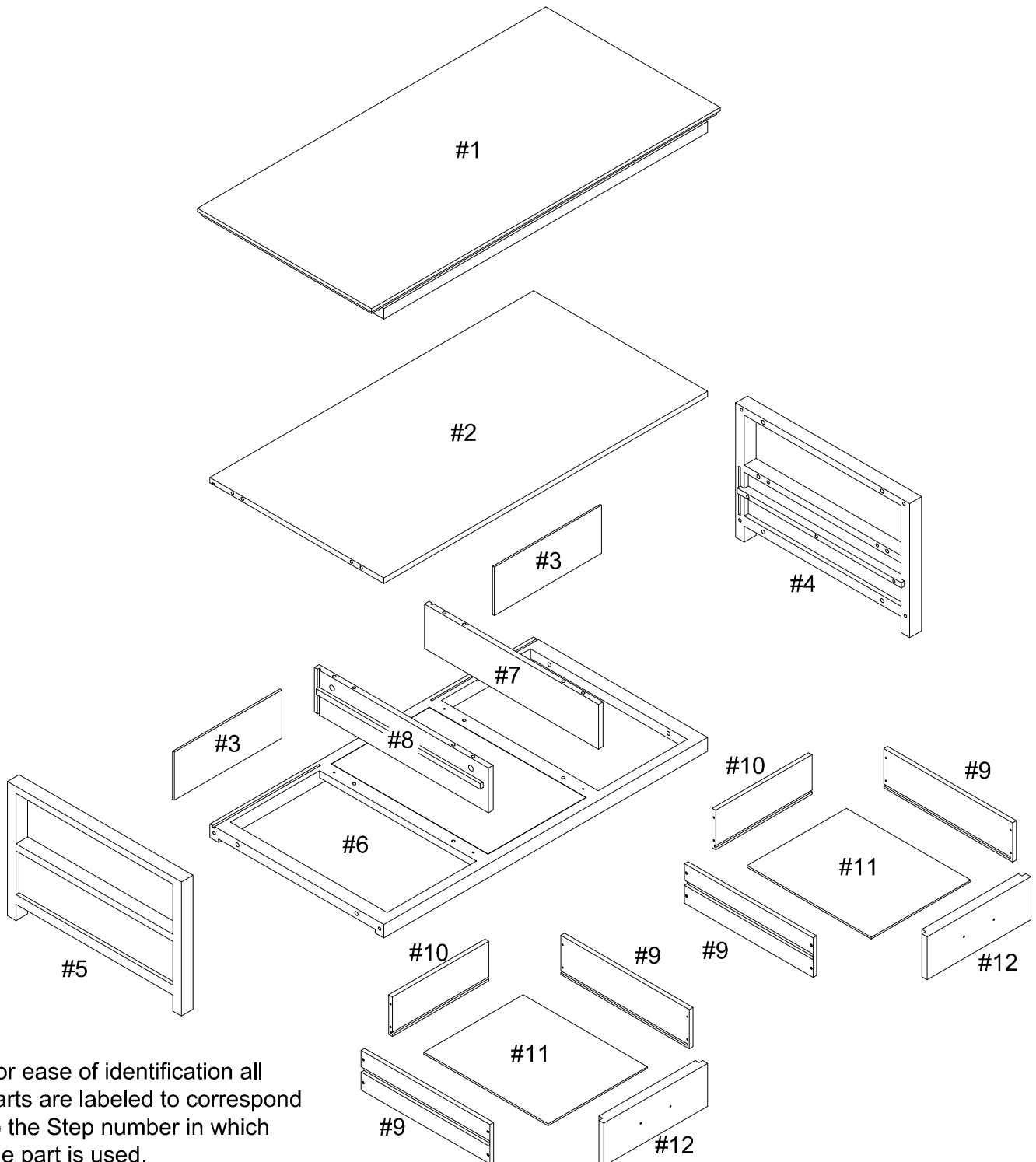

For ease of identification all parts are labeled to correspond to the Step number in which the part is used.

If any parts are missing or damaged in this package, we will be happy to provide you with replacement parts, at no charge, within 30 days of purchase, providing the parts are available in our warehouse and the item purchased is part of our current inventory. In order to receive spare parts, at no charge, you must provide proof of purchase within 30 days.

Call us toll free Or visit our web site to order spare parts and for care instructions on your newly purchased furniture.

## PARTS IDENTIFICATION







<b>ITEM</b>	<b>DESCRIPTION</b>	<b>QTY</b>
<b>#1</b>	<b>TOP PANEL</b>	<b>01</b>
<b>#2</b>	<b>CENTER SHELF</b>	<b>01</b>
<b>#3</b>	<b>BACK PANEL</b>	<b>02</b>
<b>#4</b>	<b>RIGHT SIDE FRAME</b>	<b>01</b>
<b>#5</b>	<b>LEFT SIDE FRAME</b>	<b>01</b>
<b>#6</b>	<b>BOTTOM FRAME</b>	<b>01</b>
<b>#7</b>	<b>RIGHT DIVIDER</b>	<b>01</b>
<b>#8</b>	<b>LEFT DIVIDER</b>	<b>01</b>
<b>#9</b>	<b>DRAWER SIDE</b>	<b>04</b>
<b>#10</b>	<b>DRAWER BACK PANEL</b>	<b>02</b>
<b>#11</b>	<b>DRAWER BOTTOM PANEL</b>	<b>02</b>
<b>#12</b>	<b>DRAWER FRONT PANEL</b>	<b>02</b>

If any parts are missing or damaged in this package, we will be happy to provide you with replacement parts, at no charge, within 30 days of purchase, providing the parts are available in our warehouse and the item purchased is part of our current inventory. In order to receive spare parts, at no charge, you must provide proof of purchase within 30 days.

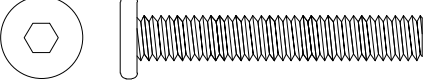
Call us toll free at Or visit our web site to order spare parts and for care instructions on your newly purchased furniture.

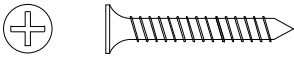
# HARDWARE IDENTIFICATION

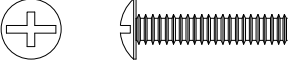
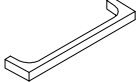
Please line up the hardware with the correct full size image to make sure you are installing the hardware correctly.

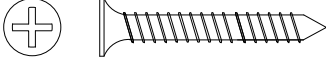

ITEM	PICTURE	DESCRIPTION	QTY
A		( $\text{Ø}\frac{1}{4}$ "x1 $\frac{1}{2}$ ") Full size	BOLT 08
B		( $\text{Ø}8$ x30mm) Full size	WOOD DOWEL 20
C		( $\text{Ø}\frac{1}{8}$ "x1") Full size	SCREW 16
D		( $\text{Ø}\frac{1}{4}$ "x $\frac{5}{8}$ ") Not to Scale	NUT 08
E		( $\text{Ø}\frac{3}{16}$ "x $\frac{3}{4}$ ") Full size	SMALL BOLT 04
F		Not to Scale	HANDLE 02
G		Not to Scale	CAM LOCK 08
H		Not to Scale	CAM BOLT 08
I		( $\text{Ø}\frac{1}{8}$ "x1 $\frac{3}{16}$ ") Full size	SCREW 04

If any parts are missing or damaged in this package, we will be happy to provide you with replacement parts, at no charge, within 30 days of purchase, providing the parts are available in our warehouse and the item purchased is part of our current inventory. In order to receive spare parts, at no charge, you must provide proof of purchase within 30 days.

Call us toll free Or visit our web site to order spare parts and for care instructions on your newly purchased furniture.

## HARDWARE IDENTIFICATION

Please line up the hardware with the correct full size image to make sure you are installing the hardware correctly.

ITEM	PICTURE	DESCRIPTION	QTY
J	 Not to Scale	DRAWER STOP	02
K	 (Ø <sup>1</sup> / <sub>8</sub> " x <sup>1</sup> / <sub>2</sub> " Full size	SMALL SCREW	02
L	 Not to Scale	ALLEN WRENCH	01

If any parts are missing or damaged in this package, we will be happy to provide you with replacement parts, at no charge, within 30 days of purchase, providing the parts are available in our warehouse and the item purchased is part of our current inventory. In order to receive spare parts, at no charge, you must provide proof of purchase within 30 days.

Call us toll free Or visit our web site to order spare parts and for care instructions on your newly purchased furniture.

STEP 1.

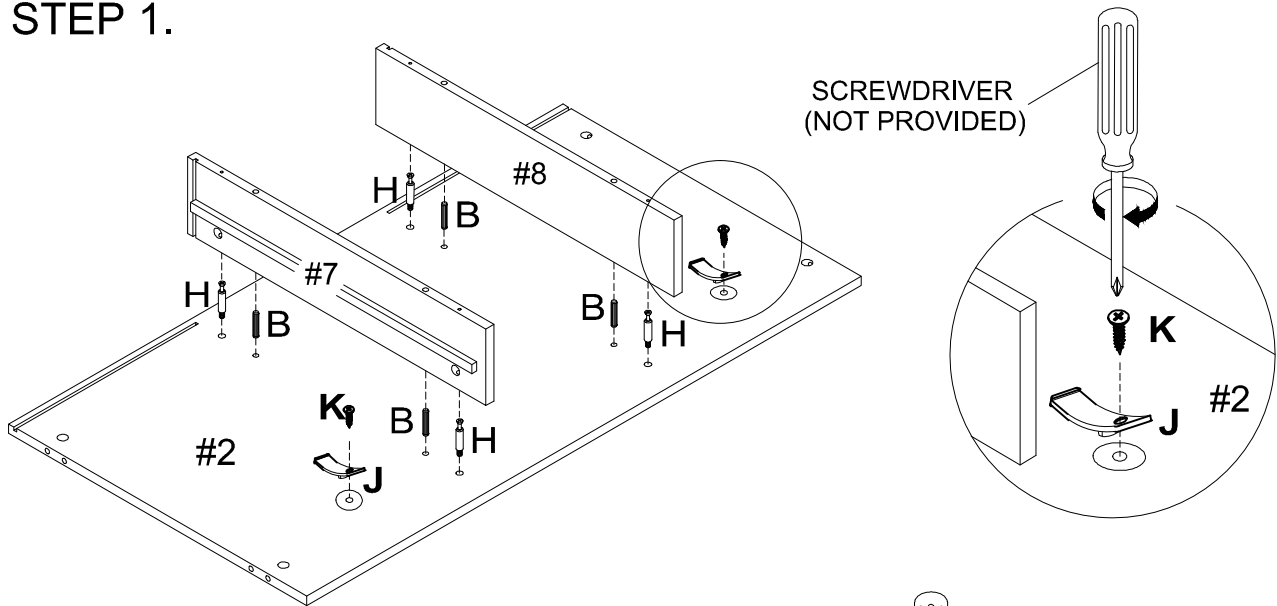

STEP 2.

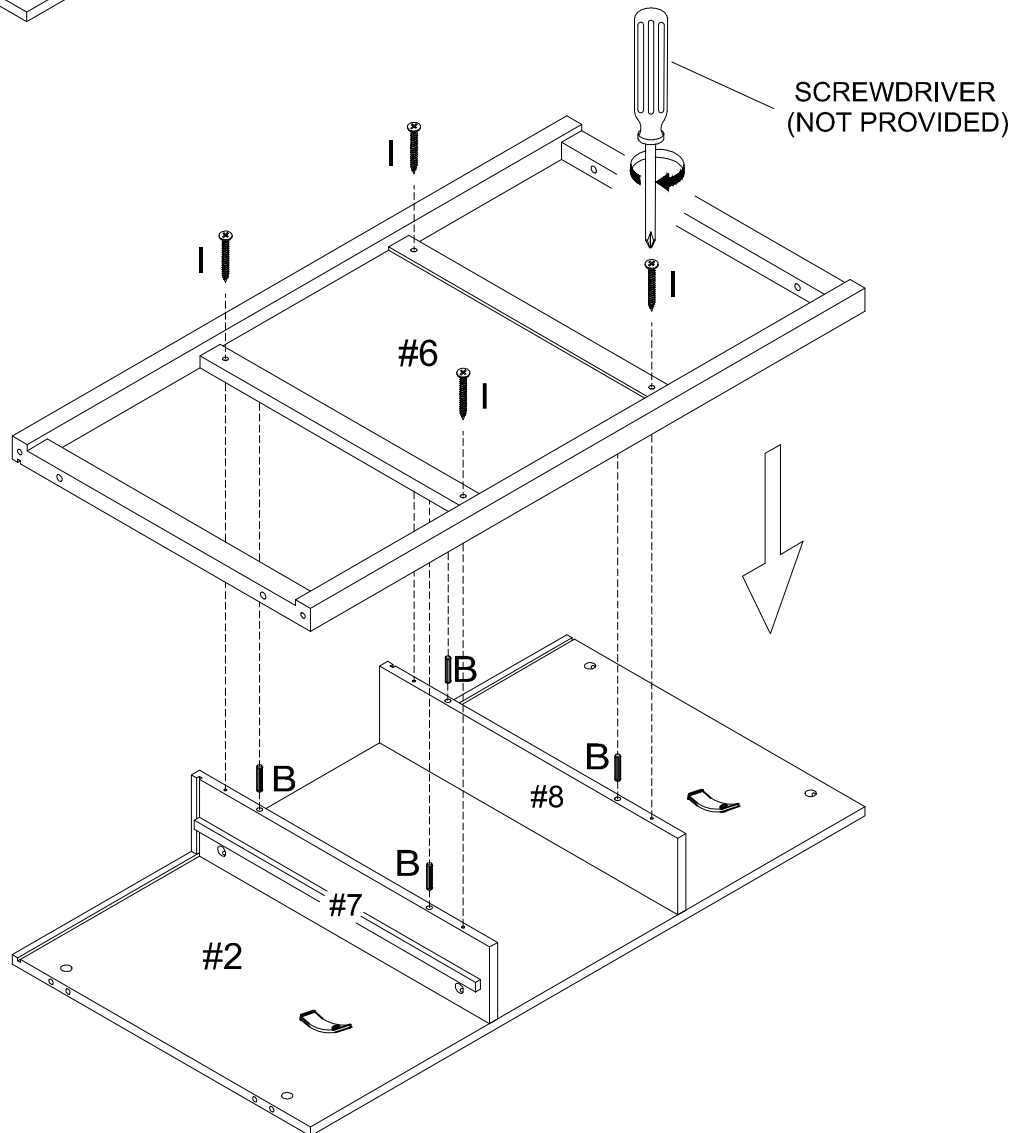

IMPORTANT:

1. DO NOT TIGHTEN BOLTS COMPLETELY UNTIL ALL BOLTS ARE COMPLETELY LINED UP AND INSERTED INTO HOLES / NUTS.
2. DO NOT OVER TIGHTEN SCREWS AND BOLTS TO AVOID STRIPPING.

STEP 3.

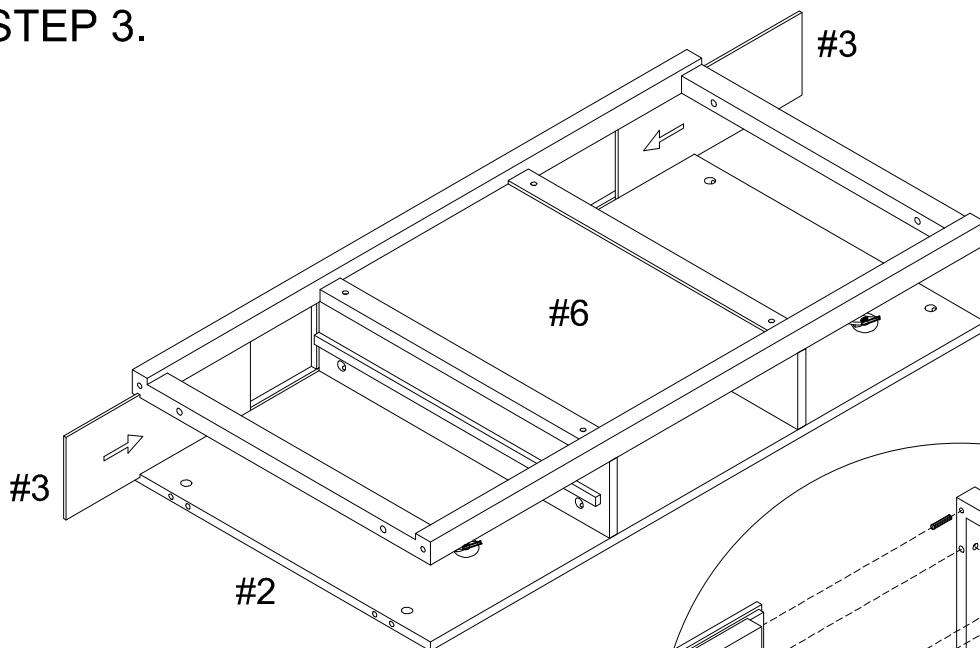

STEP 4.

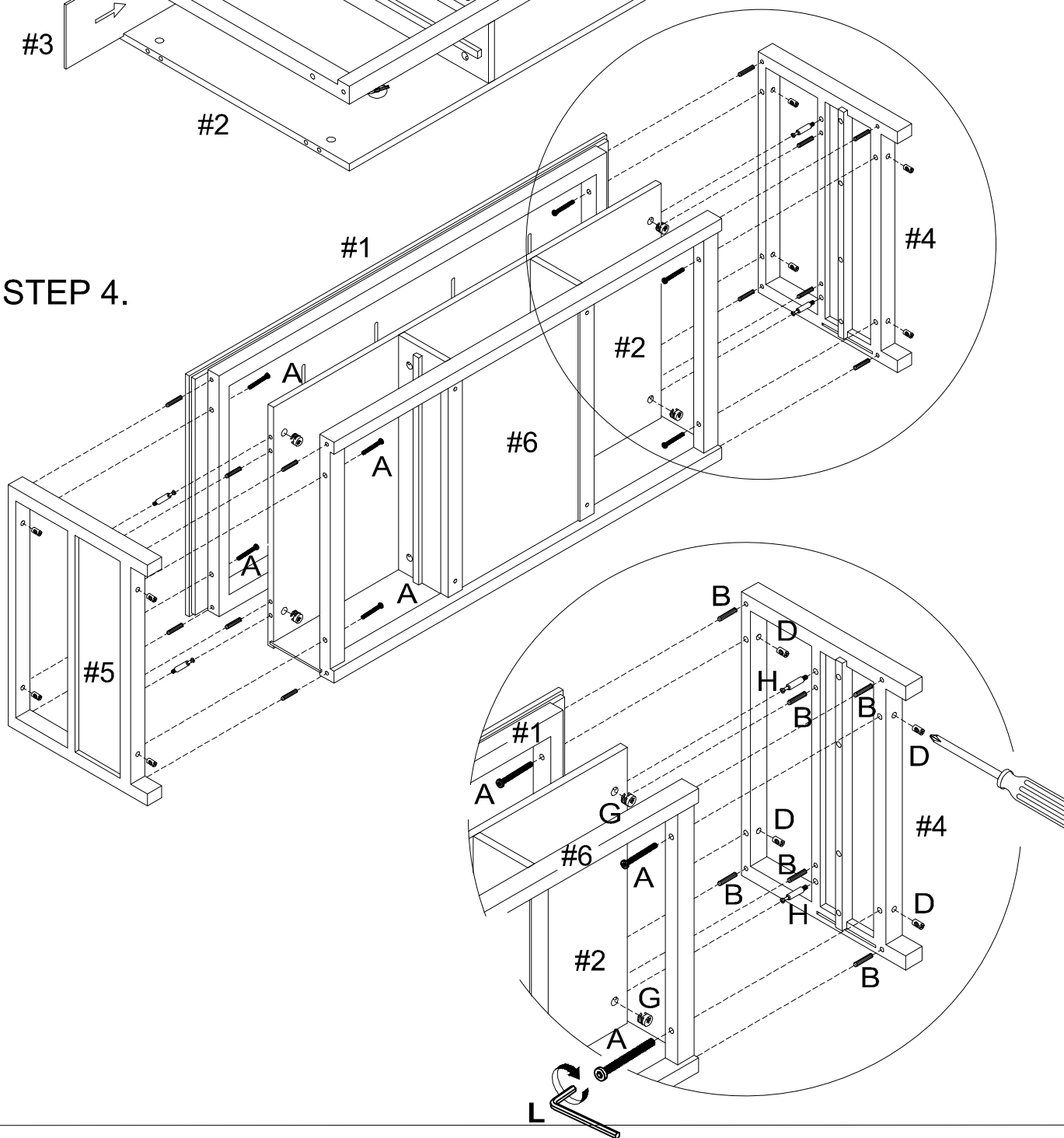

STEP 5.

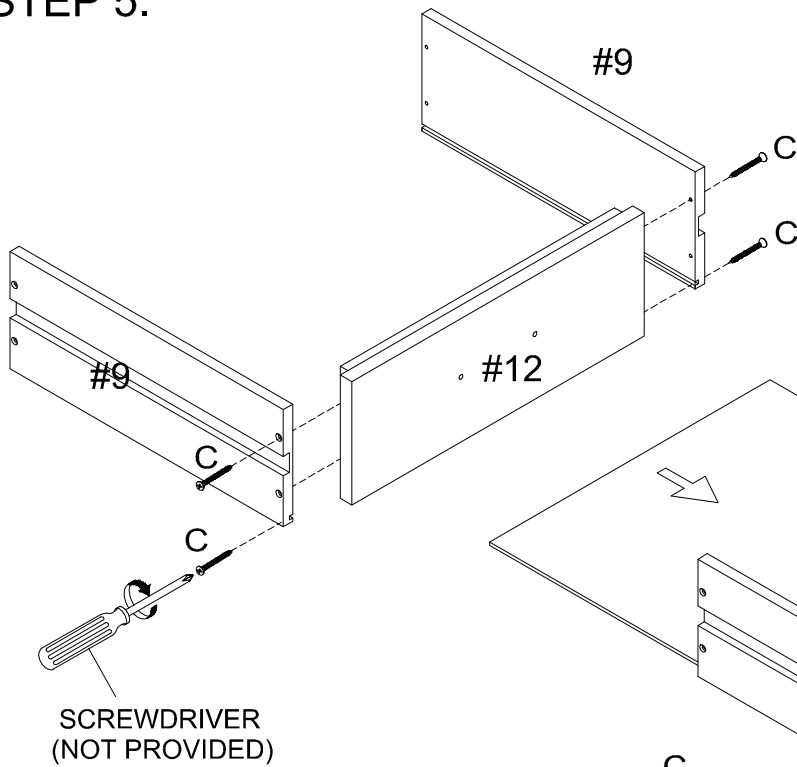

STEP 6.

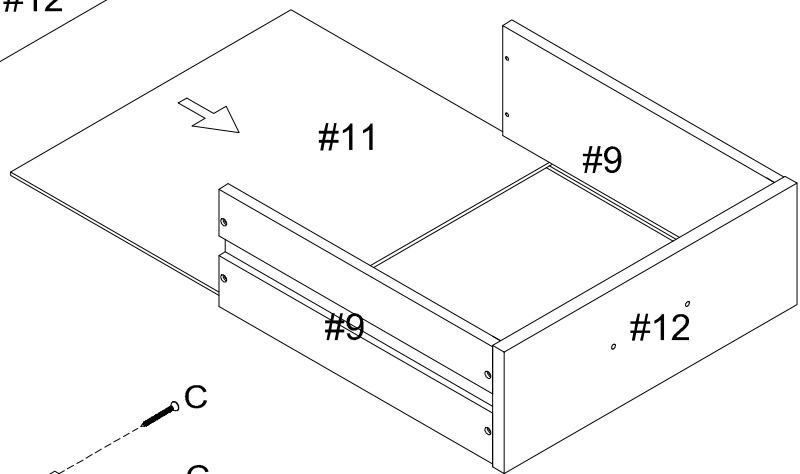

STEP 7.

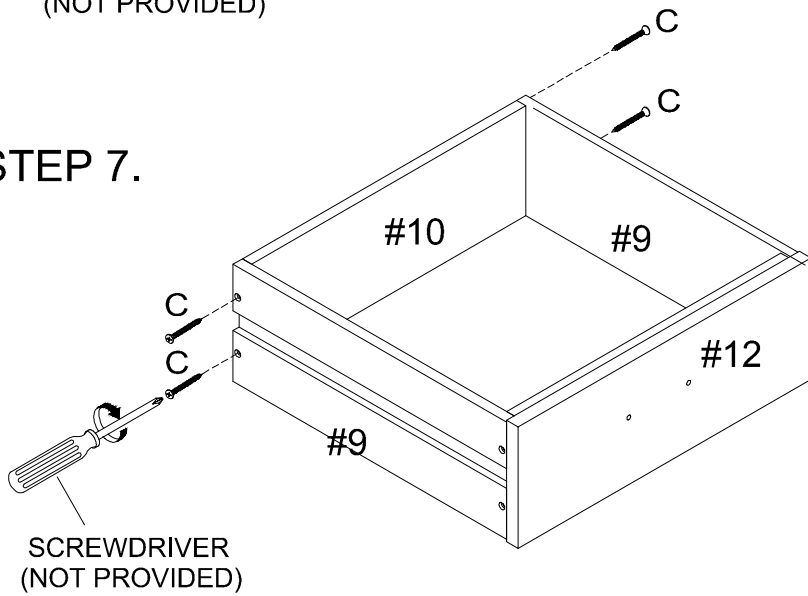

STEP 8.

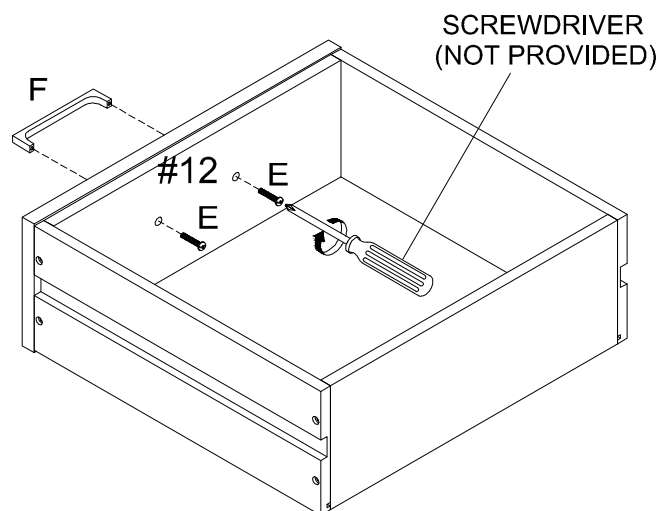

REPEAT STEP 5 TO STEP 8 ON THE OTHER DRAWER

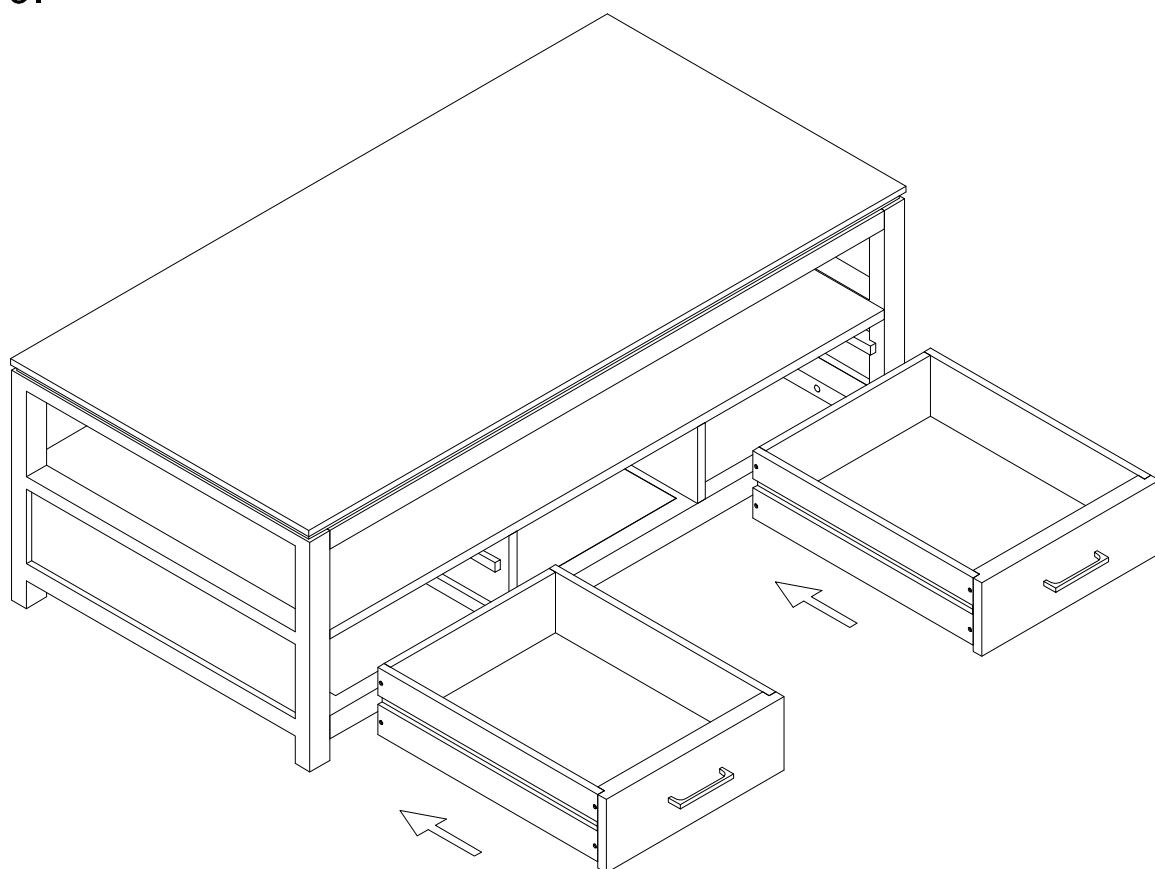
**STEP 9.****WARNING**

Serious or fatal crushing injuries can occur from furniture tip-over. To help prevent tip-over:

- .Place heaviest items in the lowest drawers.
- .Unless specifically designed to accommodate, do not set TVs or other heavy objects on the top of this product.
- .Never allow children to climb or hang on drawers, doors, or shelves.
- .Never open more than one drawer at a time.

Use of tip-over restraints may only reduce, but not eliminate, the risk of tip-over.

This is a permanent label. Do not attempt to remove!

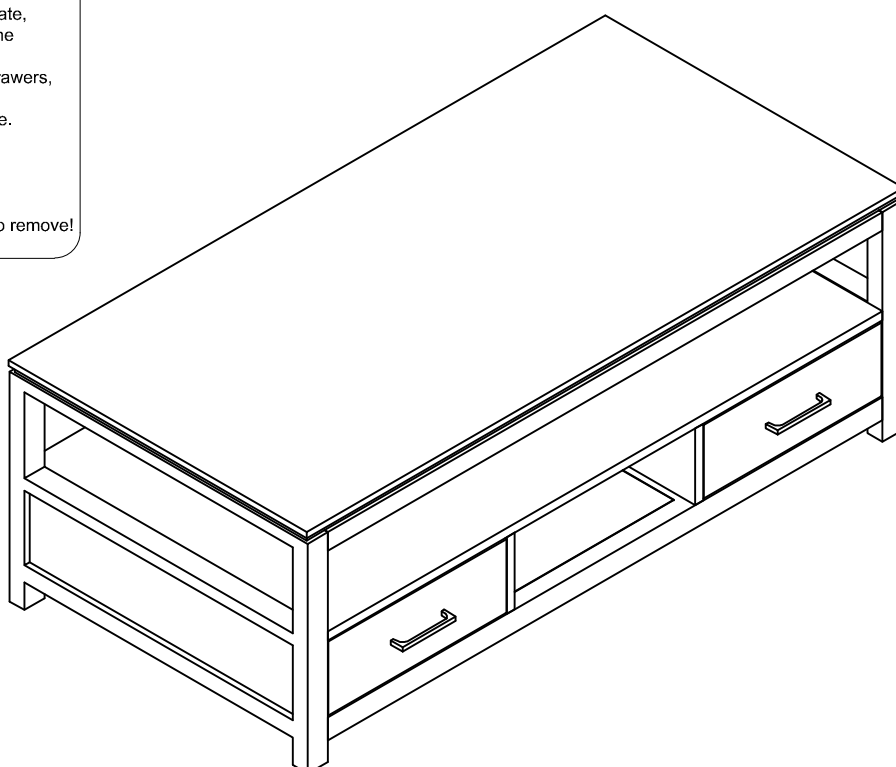

## **LIMITED 6 MONTHS WARRANTY**

### **WHAT IS COVERED**

This product is covered under our manufacturer's 6 months limited warranty. To ensure your complete satisfaction, this warrants to the original purchaser that this supplied item is free from defects in material and workmanship, as of the date of purchase, and that it will, under normal use and proper care, remain so for six months after the date of purchase.

Replacement of missing or initially defective parts will be sent, at no charge, for a period of 30 days from the date of purchase with valid proof of purchase providing the parts are available in our warehouse and the item purchased is part of our current inventory.

### **WHAT IS NOT COVERED**

It remains the customer's responsibility for freight and packaging charges to and from the customer service center. Labor and material charges to remove or replace parts under this warranty are not covered.

This warranty does not cover: Furniture used for commercial purposes, failures caused by improper installation assembly or by improper care, unreasonable or abusive use, freeze damage, acts of God, rust, purchased parts or return freight and packaging charges. Proof of purchase (dated register receipt) is required for warranty claims.

### **HOW TO OBTAIN SERVICE**

For further information, please contact our customer service department