

Mass: 204.5 kg



Follow and Tag Us: @shiregardenbuildings

Batch No: 6651

© Overlap Pent 16x6

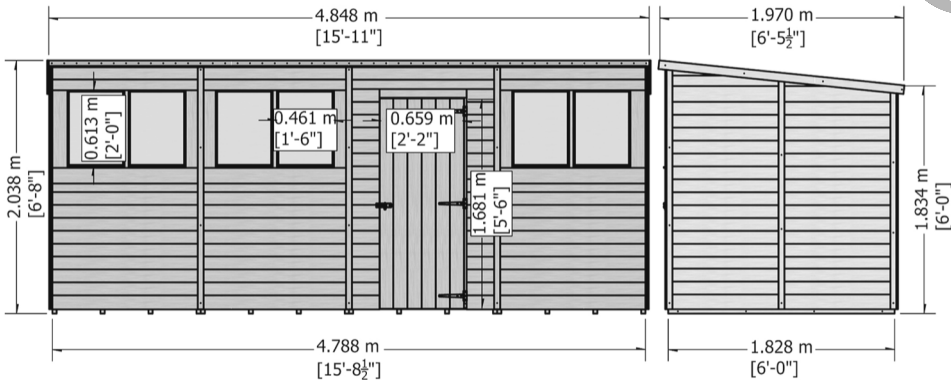
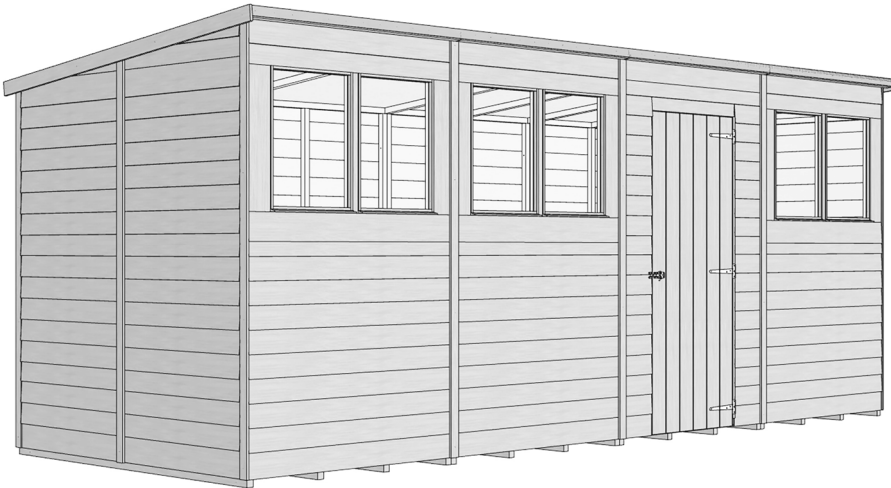

Version 02 14/01/2025 Sasha Loney

**These instructions are for your safety. Please read through them thoroughly before use.
PLEASE KEEP THIS LEAFLET FOR FUTURE REFERENCE**

Let's get started...

Important information...



Safety	03
Preparation of base	04
Warranty	04
Care, maintenance & Recycling	05

In more detail...



Parts List	06
Fascia & Nail List	07
Detailed Technical Drawing	08-10
Hardware Chart	10
Before You Start	11
Assembly instructions	12-28

Like us, Follow us, Recommend us & Tag us



Shire Garden Buildings



@shiregardenbuildings



Shire Garden Buildings



customerservice@shiregb.co.uk



Brigstock Road Wisbech Cambridgeshire PE13 3JJ
Tel 01945 465 295

Safety

Check that you have noted all the following instructions:



- We advise the use of non slip protective gloves throughout the assembly process.
- We advise the use of steel capped protective footwear throughout the assembly process.
- We advise that you use a helper to hold the glass in position whilst you nail the beading in place.
- We advise the use of protective headwear and safety goggles throughout the assembly process.
- Where a ladder is in use another person must hold the ladder.
- Do not attempt to work in windy conditions.
- We advise the use of a scaffold tower when fitting the roof, for felting or if you cannot reach from the ground.
- Do not allow children near the tools and work area.
- Follow any safety precautions quoted by the manufacturer for any equipment you use.
- Check all parts before assembly.
- Only use child and animal safe wood preservative.
- Do not use creosote.
- Allow the wood preservative to fully dry before use.
- Regularly check the building for wear and tear.



Important!

EVERY PRECAUTION IS TAKEN TO ENSURE THAT YOUR BUILDING HAS NO ELEMENT INCORRECTLY PLACED OR POSSIBLY HAZARDOUS, HOWEVER PRIOR TO USE PLEASE CHECK ALL SURFACES FOR THE FOLLOWING:

- (1) RAISED GRAIN, SPLINTERS: Sand down timber to smooth finish
- (2) NAIL/SCREW/PIN HEADS PROUD: Tap home to be flush with surface of timber.
- (3) DAMAGED SCREW HEADS RESULTING IN SHARP SPLINTERS OF METAL: Replace.
- (4) SHARP ENDS OF NAILS/ SCREWS/ PINS PROTRUDING THROUGH THE PANEL: Remove and reposition.
- (5) ENSURE ALL PARTS ARE SECURED AGAINST REASONABLE FORCE: Remove and refit.
- (6) ENSURE THERE ARE NO LOOSE PARTS: Remove and refit/discard.



IMPORTANT ! For your safety please read carefully the safety warnings

Preparation of base...

We recommend that the base onto which your building will stand should be at least 75mm larger in each direction than the total floor size of the building.

- **Actual floor area of the building:** 4788mm x 1828mm
- **Total height clearance:** 2038mm
- **Roof size:** 4848mm x 1970mm

The chosen position in your garden for your building should be excavated to a depth of 75mm to allow a base of sand, on to which paving slabs can be evenly laid. You may also use an adjustable timber base or a concrete base. Whatever base you decide upon IT MUST BE LEVEL AND FIRM.

Warranty...

10 Year anti rot warranty subject to the following:

- The building must be raised so it is not in contact with any water retaining base surface (for example grass).
- This can be achieved using a timber, concrete or slab base.
- When using a concrete or slab base use damp proofing strips under the bearers.
- The building must have been completely treated and sealed prior to assembly.
- The building must have been re-treated and re-sealed annually.

NOTE: Wood is a natural product, and therefore the following are excluded from the warranty:

- Colour change.
- Warping.
- Splitting.

The following are also excluded:

- Damage resulting from poor assembly.
- Poor treatment application.
- Poor care and maintenance.
- Changes to the design.
- Misuse.
- General wear and tear.

Building Photographs

It will be greatly appreciated if you could forward images of your completed building to -

sales@shiregb.co.uk.

Care, Maintenance and Recycling

The 5 golden rules of care:

- (1) Ensure your base is level and firm.
- (2) Ensure the building is not sitting directly on the ground using damp proof membrane or the optional timber base.
- (3) Ensure every piece of timber and surface, especially that is hidden upon assembly, is treated with a top quality wood preservative at least twice (before assembly). Turn the panels upside down whilst painting so the treatment runs into the seams.
- (4) Garden buildings are not waterproof, therefore you must seal between all the panels with a silicone based sealant.
- (5) Regularly check your roofing felt for weather damage and leaks.

The 6 golden rules of maintenance:

- (1) Visually check for weather damage.
- (2) Check and replace if necessary any Silicone sealant if used on your building.
- (3) Check the roofing material for wear.
- (4) The doors and windows may require periodical adjustment.
- (5) Ensure your building is well ventilated especially during hot weather.
- (6) During extremely hot periods humidify your building to prevent the timber from drying out.

Recycling and disposal:



packaging

1. Pallet and timber widely recycled.
2. Cardboard widely recycled.
3. Plastic strapping subject to local regulations.
4. Plastic sheeting subject to local regulations.



Building

1. Timber widely recycled.
2. Metal fixings widely recycled.
3. Glass widely recycled.
4. **Roofing felt not currently recycled.**

Stacked Parts List

FLOOR PANEL
(A0130)x04

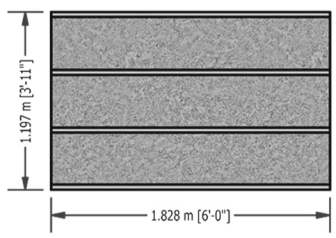

OSB 1220X1970
(A5481)x02

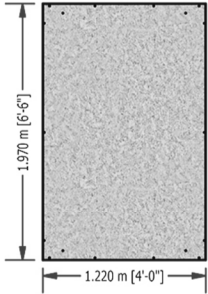

OSB 1187X1970
(A08571)x02

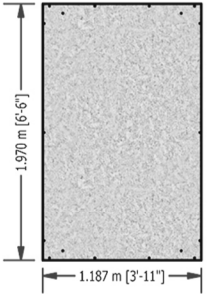

PLAIN PANEL 880
(A5229)x04

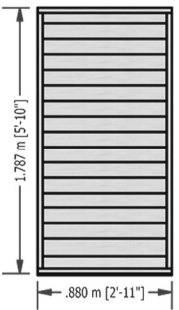

PLAIN PANEL 1197
(A5341)x04

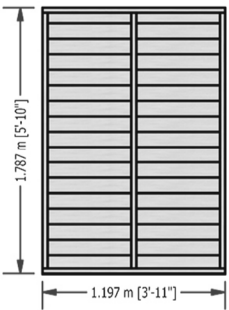

SINGLE DOOR PANEL
(A5476)x01

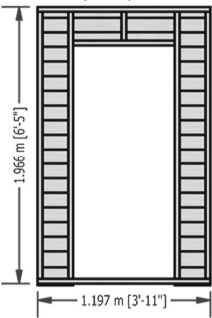

WINDOW PANEL
(A5477)x03

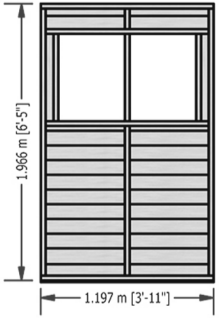

RH PENT PANEL
(A5479)x01

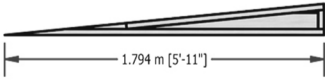

LH PENT PANEL
(A5480)x01

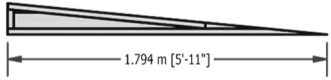

RUSTIC DOOR
(A5230)x01

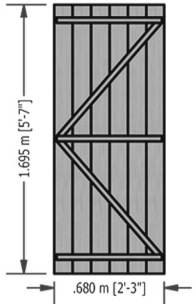

FELT STRIP 5M
(A06632)x03

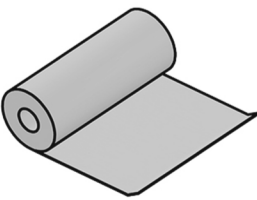

ACRYLIC 610X457
(A5282)x06

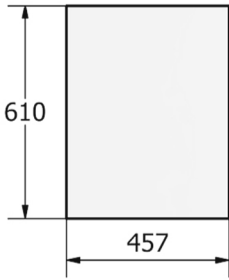

Description
(part No) - Qty

Stacked Parts List

ROOF BEARER 34X34
(A5482)x07

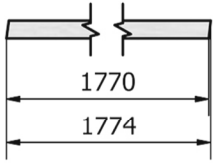

34X34X1187
(A09663)x04

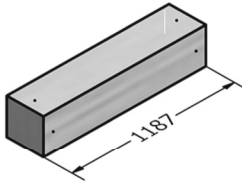

ROOF EDGE 34X34
(A06493)x04

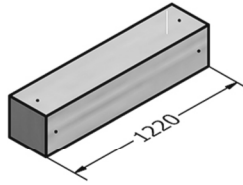

HINGE STRIP 20X46
(A5348)x01

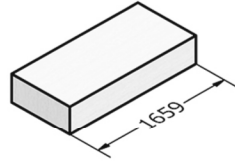

COVERSTRIP 12X48X1800
(A5231)x05

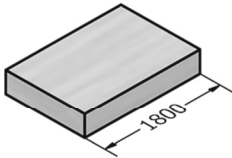

COVERSTRIP 12X48X1980
(A5495)x05

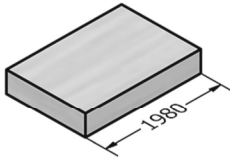

Description
(part No) - Qty

Fascia and Nail Bag Parts List

SQUARE FASCIA 12X70X1990
(A3991)x02

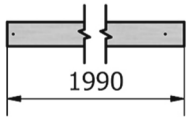

COVERSTRIP 12X48X1890
(A5496)x02

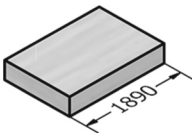

DOOR STOP 12X28X660
(A2853)x01

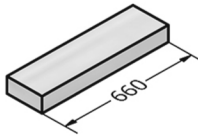

DOOR STOP 12X28X1659
(A5324)x02

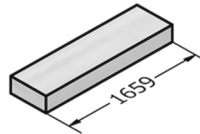

BLOCK 34X34X150
(A0065)x01

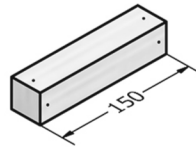

WINDOW SILL 460MM
(A1626)x06

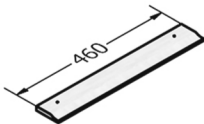

WINDOW BEAD 613MM
(A1565)x24

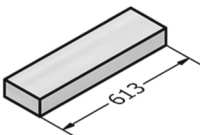

WINDOW BEAD 436MM
(A1628)x24

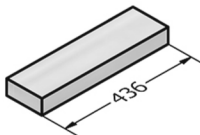

TEE HINGE
(A0049)x03



PAD BOLT
(A0053)x01

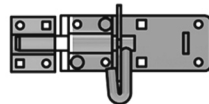

In more detail.....

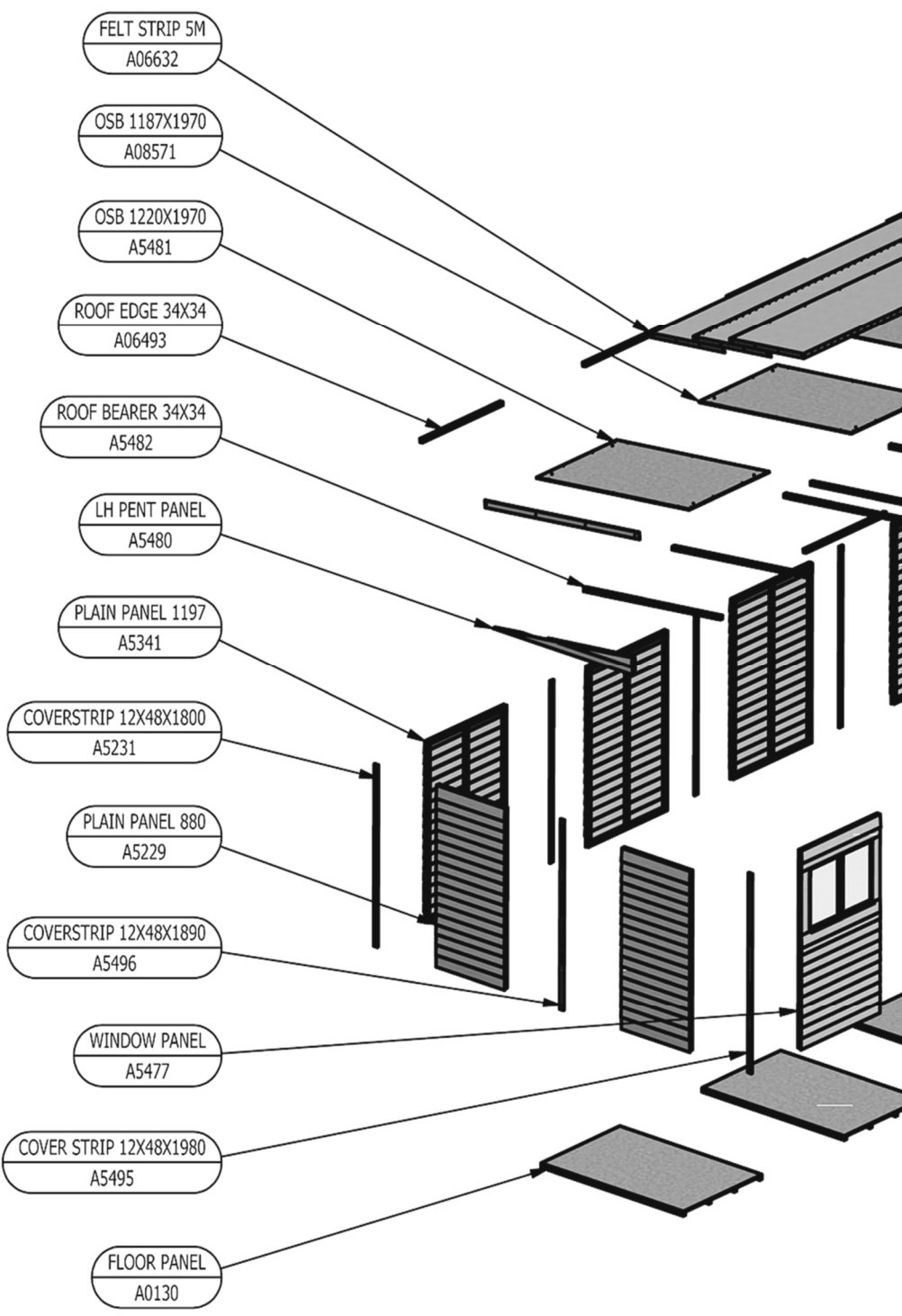

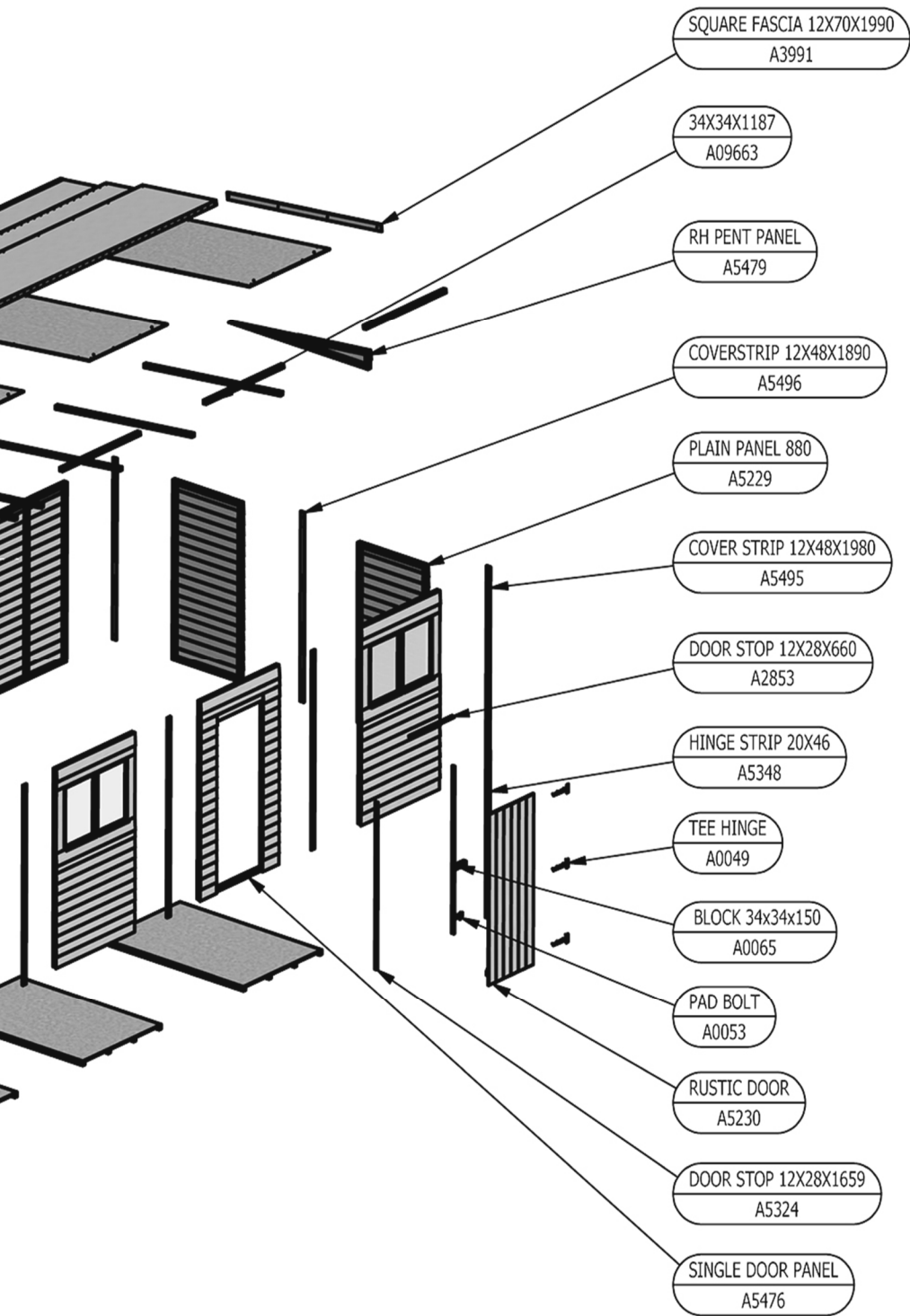

In more detail.....

In more detail.....

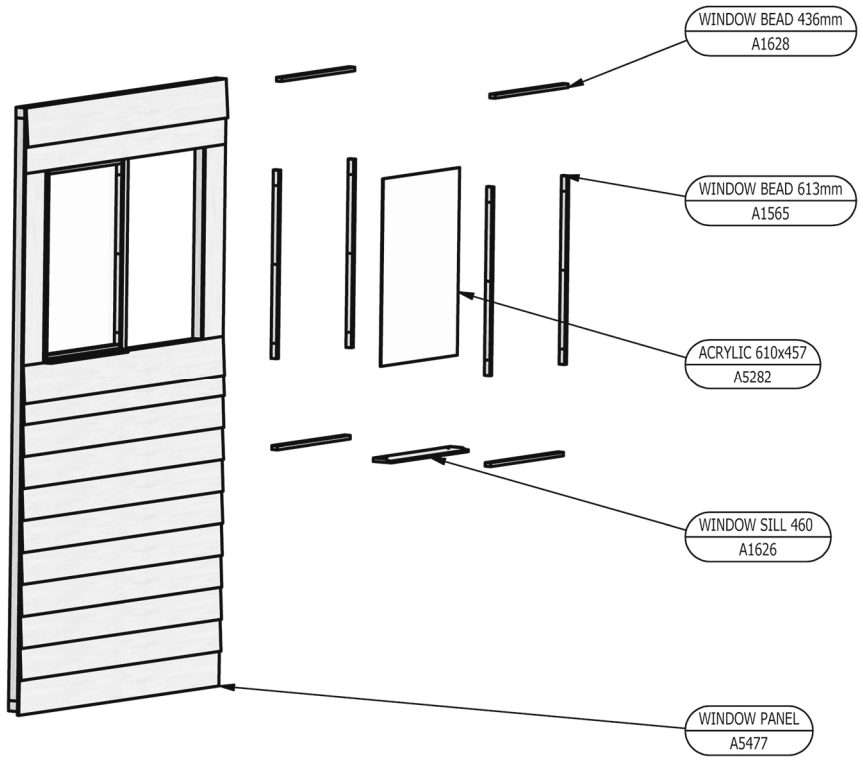

Description (part No) - Qty

Nail bag contents

Hardware Chart Scale 1:1

8mm Felt Nail (A0266) x201



40mm Round head nail (A0025) x255

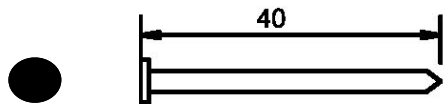

25mm Posi-drive screw (A0032) x27

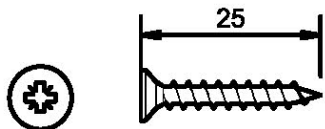

60mm Posi-drive screw (A0035) x90

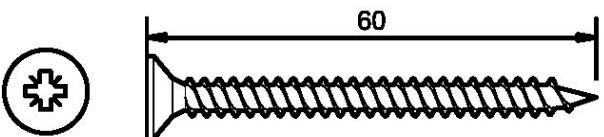

Before you start...

Things to check before you start:

- ✓ Ensure your base is ready – See page 4.
- ✓ Check all parts as listed in the parts lists.
- ✓ Read the instructions fully before starting work.
- ✓ Follow all the health and safety guidelines.



When you see the drill icon
Only ever drill through the first piece of framework which will be a pilot hole for the screw to attach the second piece of framework
The required drill bit size is shown with the icon.

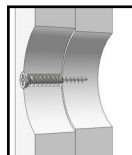
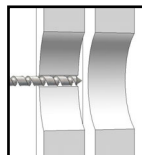

You will need:



- Hammer



- Spirit level



- Ladder

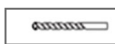

- 1mm 3mm 5mm 8mm drill bit



- Drill

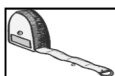

- Tape measure & Ruler

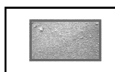

- Sand paper



- Gloves



- Saw

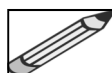

- Pencil



- Goggles

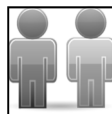

- A helper for some tasks

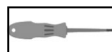

- Screwdriver



- Sharp knife



- Masking tape

Assembly instructions:

These instructions are for your safety. Please read through them thoroughly before use.
Treat all the parts before assembly – see page 5!

GB-IE The Door, Window and Plain Wall Panels FIT OUTSIDE THE PENT PANELS!

The "Panel Layout" is showing you how the panels can be swapped.

01

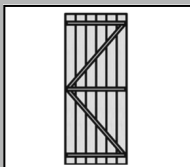

Rustic Door (A5230)x01

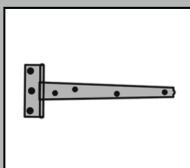

Tee Hinge (A0049)x03

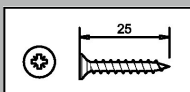

25mm Screws (A0032)x12

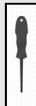
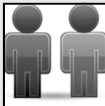
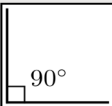

DOOR AND WINDOW PANELS CAN BE SWAPPED

DOOR CAN BE LEFT OR RIGHT HAND HUNG

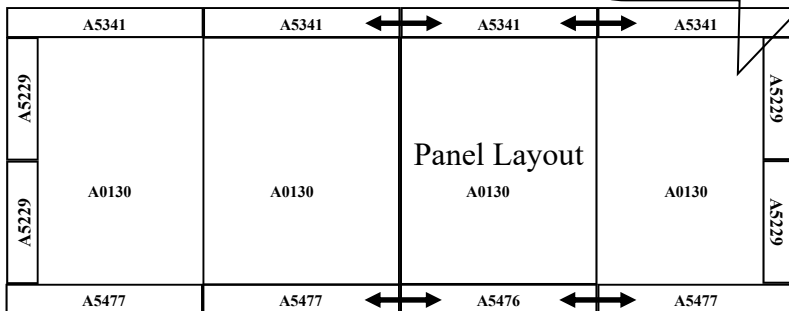

HINGE THIS SIDE

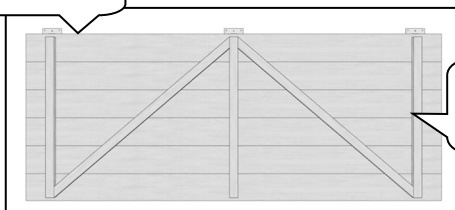

BACK OF DOOR VIEW

INSIDE VIEW GAP

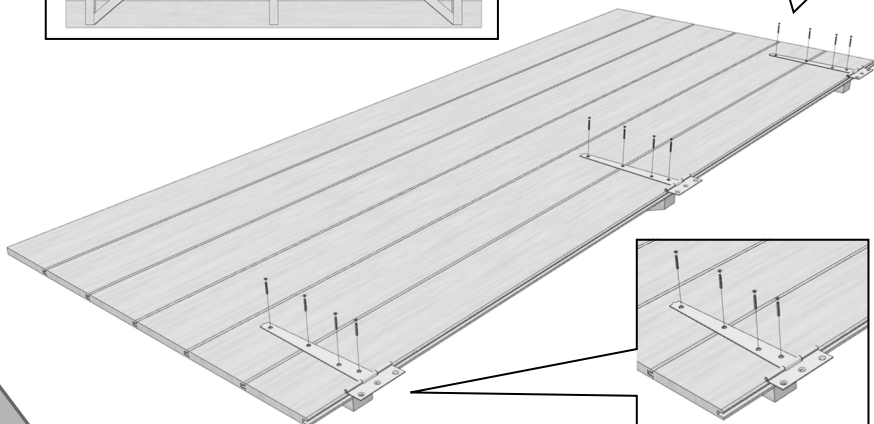
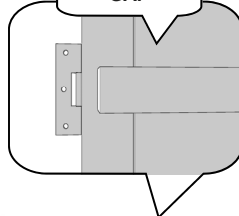

Lay the **Rustic Door (A5230)** cladding up as above. Fix the **Tee Hinges (A0049)** on the framework on the back of the door as above. Use 4x **25mm Screws (A0032)** per hinge.

GB-IE

12

Tip: Make sure hinges move freely before tightening all the screws.

GB-IE

Carefully lay the **Single Door Panel (A5476)** flat.
Nail the **Hinge Strip 20x46 (A5348)** so that its flush with the back of the door frame, using **40mm Nails (A0025)** as shown below.

02

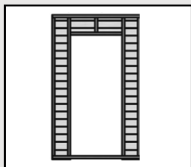
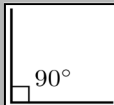

Single Door Panel (A5476)x01

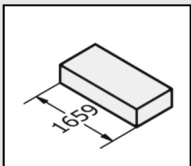

Hinge Strip 20x46 (A5348)x01

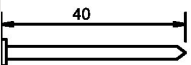

40mm Nails (A0025)x04

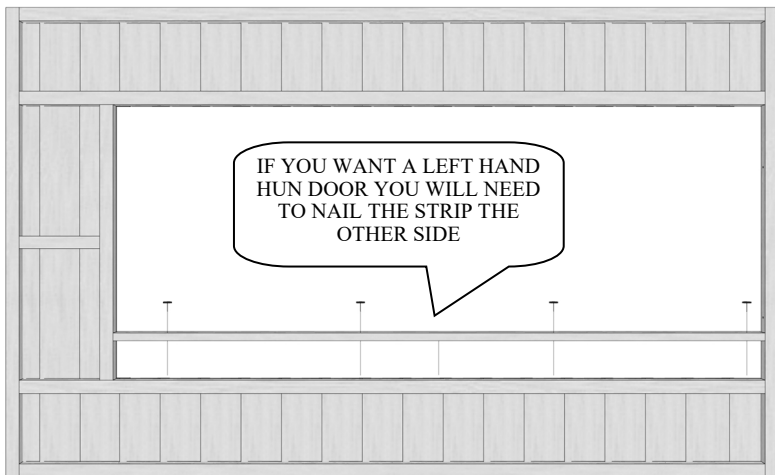

GB-IE

Lay the **Door (Step 1)** within the **Single Door Panel (A5079)** as below. Make sure the panel is wider at the top. Door can be left or right hand hung. Secure using 3x **25mm Screws (A0032)** per hinge. Make sure the door can open and close smoothly before tightening the screws.
Tip: Use coins as packing or something similar to ensure door is level.

03

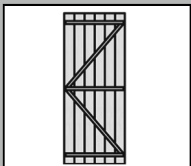
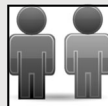
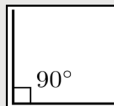

Rustic Door (Step 01)x01

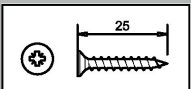

25mm Screws (A0032)x09

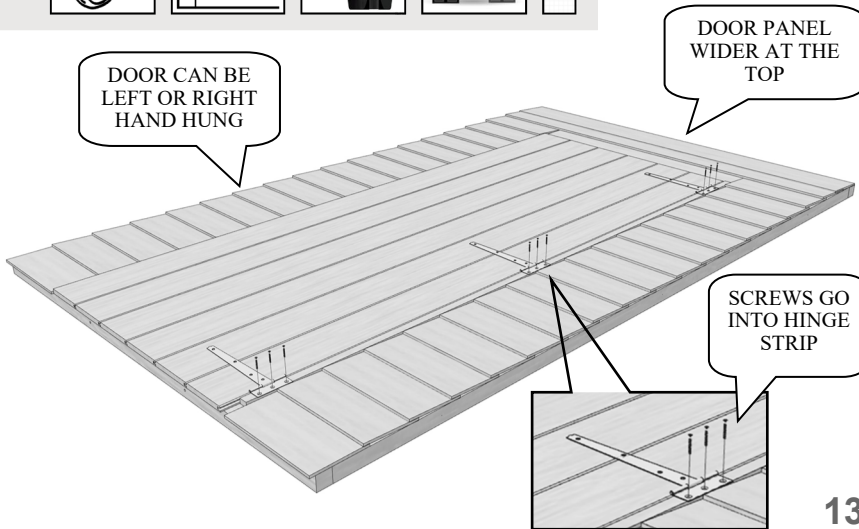

GB-IE

Fit the **Door Stop 12x28x660 (A2853)** and then the **Door Stop 12x28x1659 (A5324)** flush with the outside edge of the framework, not the cladding.
Nail with 3x **40mm nails (A0025)** in the top and 4x **40mm nails (A0025)** each side.

04

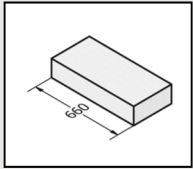

Door Stop 12x28x660 (A2853)x01

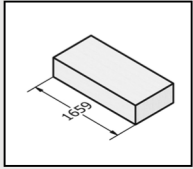

Door Stop 12x28x1659 (A5324)x02

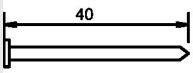

40mm Nails (A0025)x11

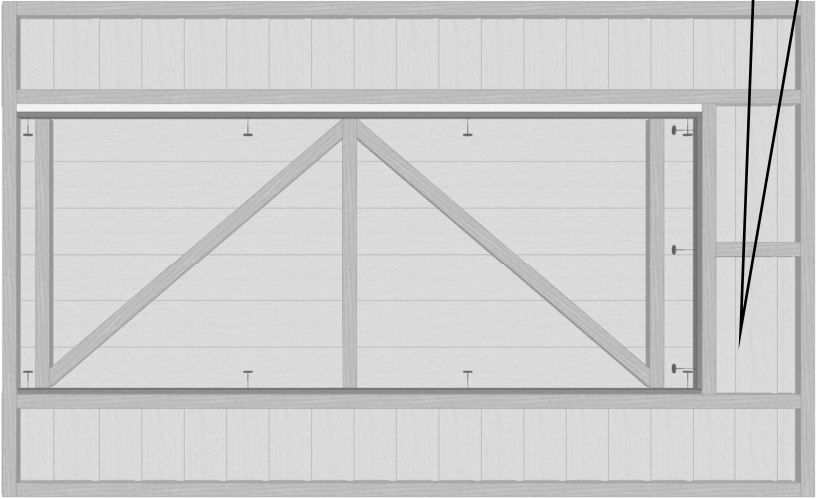
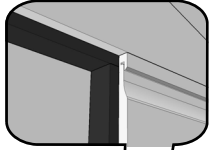
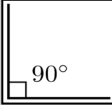

GB-IE

Drill and screw the **Block 34x34x150 (A0065)** to the inside of the door frame, so that it is level with the end of the middle bar as shown below.

05

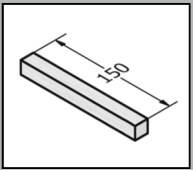

Block 34x34x150 (A0065)x01

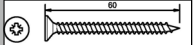

60mm Screws (A0035)x02

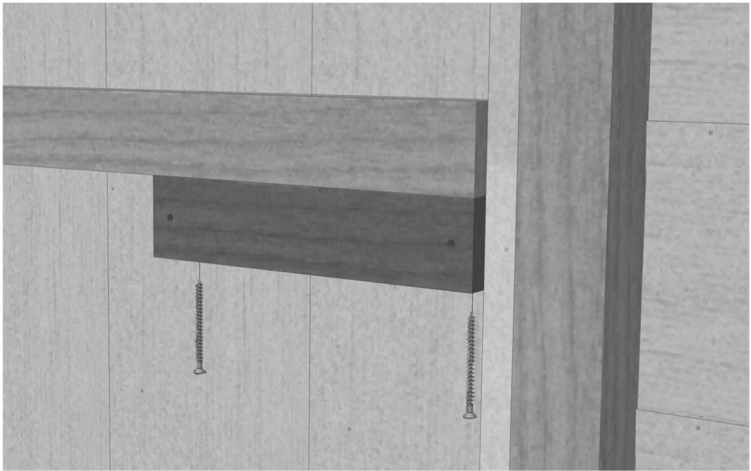
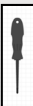
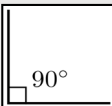

GB-IE Fix the **Pad Bolt (A0053)** so the screws go into the **Block 34x34x150 (A0065)** on the back of the door.

06

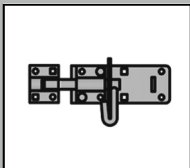

Pad Bolt
(A0053)x01

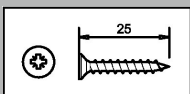

25mm Screws
(A0032)x06

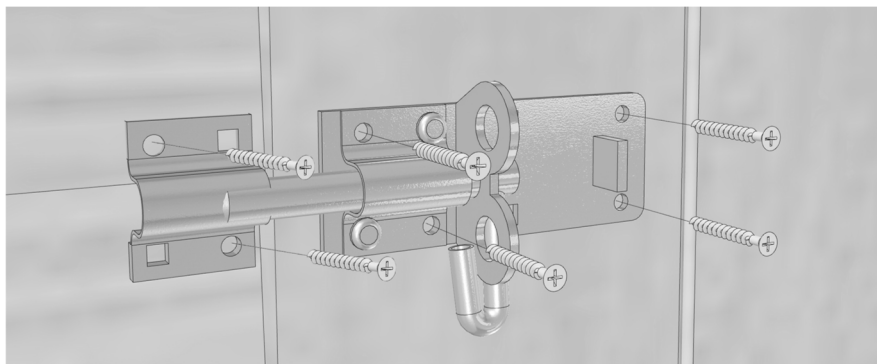
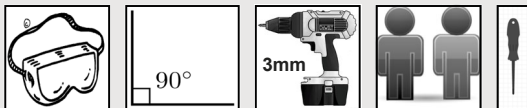

GB-IE Drill one **Floor Panel (A0130)** down both sides and one with holes down one side. Place the other **Floor Panels (A0130)** either side and screw the floors together using 4x **60mm Screws (A0035)**. Carefully turn over the floor and put it onto your chosen **base**.

07

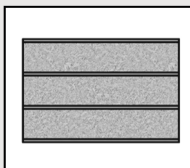

Floor Panel
(A0130)x04

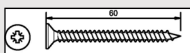

60mm Screws
(A0035)x12

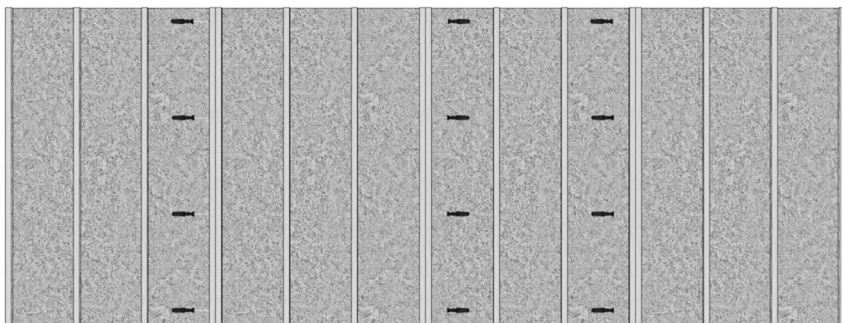
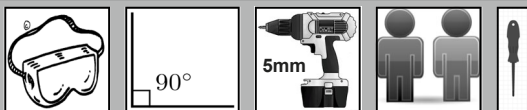

Drill one **Plain Panel 880 (A5229)** as below.

Drill one **Plain Panel 1197 (A5341)** making sure the holes are inline with the floor bearers. Place the larger plain panel into the corner of the floor, so that the cladding overlaps and push the 880 panel up to it.

Secure with 3x **60mm Screws (A0035)** using the pilot holes drilled.

08

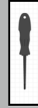
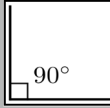

NOTE
Some holes drilled for later use

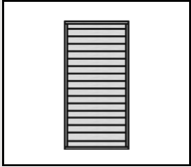

Plain Panel 880 (A5229)x01

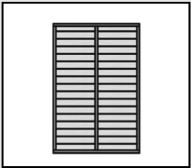

Plain Panel 1197 (A5341)x01

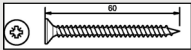

60mm Screws (A0035)x03



Inline with floor bearer

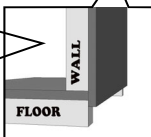
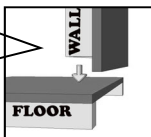
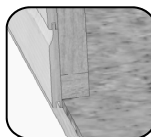
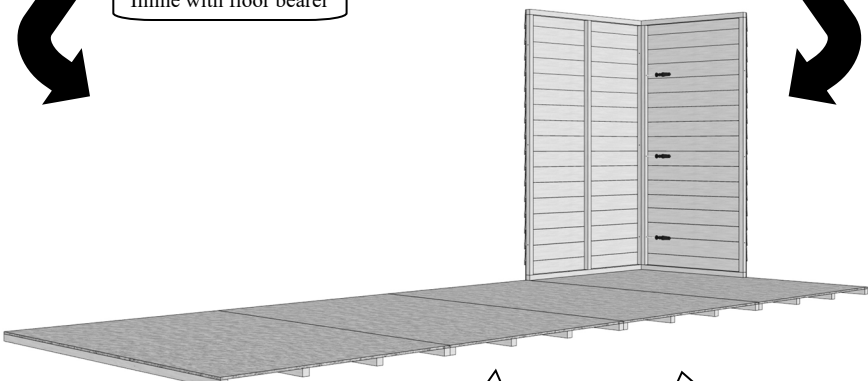

DO NOT FIX WALLS TO FLOOR UNTIL ASKED

Drill three **Plain Panels 1197 (A5341)** making sure the bottom screws are inline with the floor bearers as below.
 Place the panels onto the floor as below, making sure the cladding overlaps.
 Secure with 3x **60mm Screws (A0035)** using the pilot holes drilled in the middle and end panel.

09

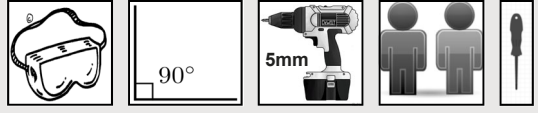

NOTE
 Some holes drilled for later use

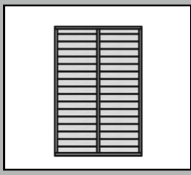

Plain Panel 1197 (A5341)x03

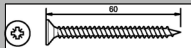

60mm Screws (A0035)x09

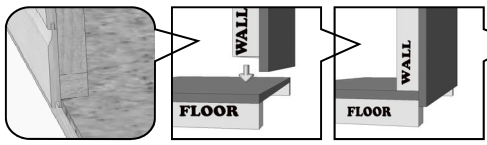

DO NOT FIX WALLS TO FLOOR UNTIL ASKED

Drill two more **Plain Panels 880 (A5229)** as below.
Place both panels onto the floor and fix with 3x **60mm Screws (A0035)** in each panel using the pilot holes drilled as below.

10

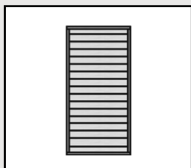
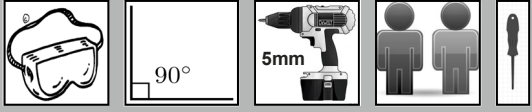

Plain Panel 880 (A5229)x02

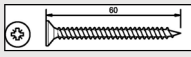

60mm Screws (A0035)x06

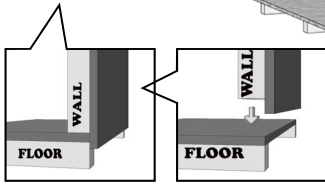
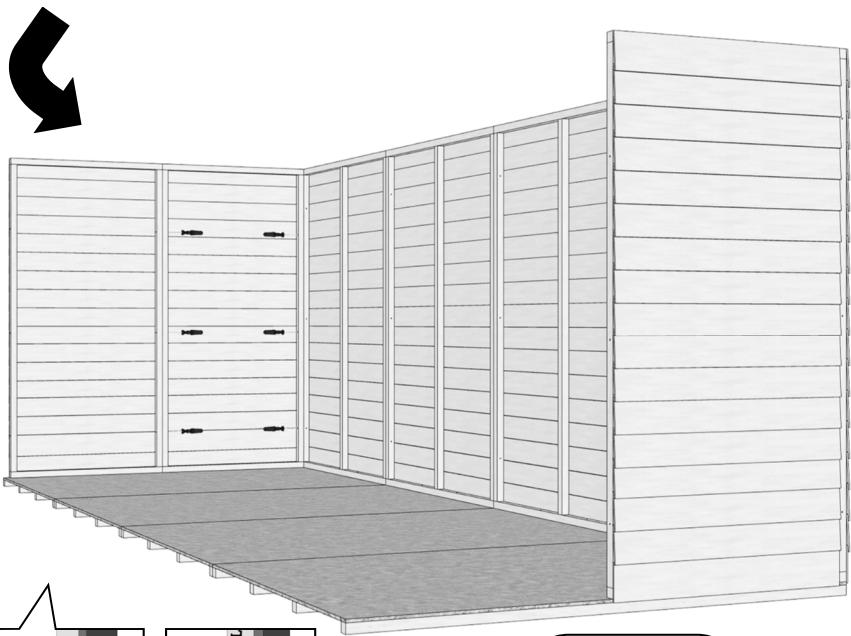
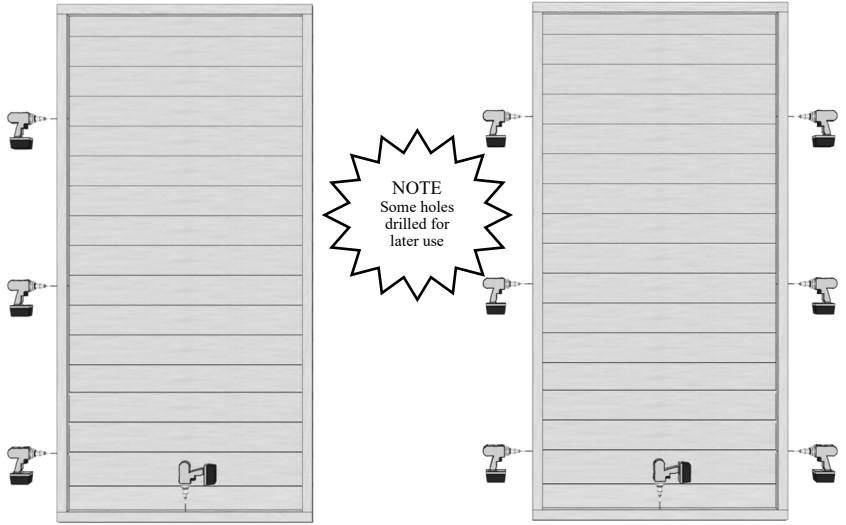

DO NOT FIX WALLS TO FLOOR UNTIL ASKED

GB-IE

Drill the last **Plain Panel 880 (A5229)** as below.
Drill one **Window Panel (A5477)**, making sure the holes are inline with the floor bearers.
Place both panels onto the floor and fix with 3x **60mm Screws (A0035)** using the pilot holes drilled as below.

11

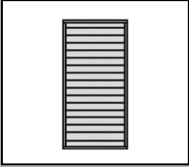
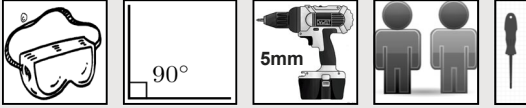

Plain Panel 880 (A5229)x01

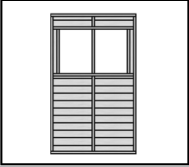

Window Panel (A5477)x01

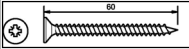

60mm Screws (A0035)x06



NOTE
Some holes drilled for later use

Inline with floor bearer

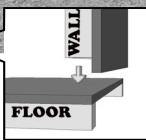
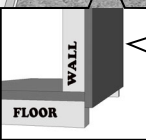
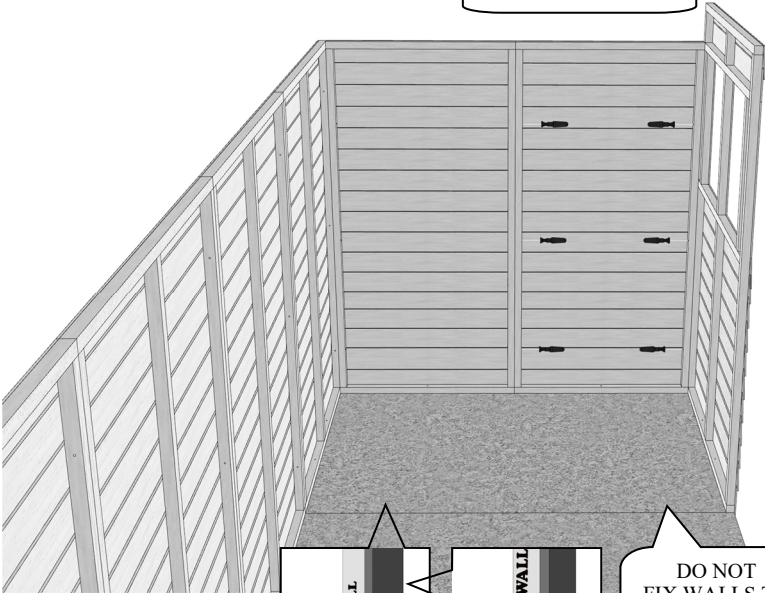

DO NOT
FIX WALLS TO
FLOOR
UNTIL ASKED

Open the Door.
Drill the **Single Door Panel (Step 01-06)** and two **Window Panels (A5477)** as below.
Make sure the bottom holes are inline with the floor bearers and the side holes are at an angle in the window panel.
Place the panels as below and secure with **60mm Screws (A0035)** using the pilot holes.

12

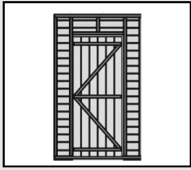

Single Door Panel (Step 01-06)x01

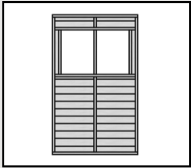

Window Panel (A5477)x02

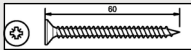

60mm Screws (A0035)x12

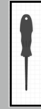
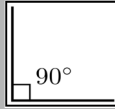

NOTE
Some holes drilled for later use

DRILL AT AN ANGLE



Inline with floor bearer



Inline with floor bearer



Inline with floor bearer

DOOR AND WINDOW PANELS CAN BE SWAPPED

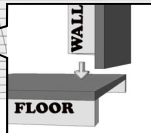
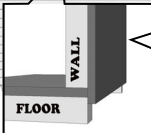

DO NOT FIX WALLS TO FLOOR UNTIL ASKED

GB-IE

Place the **RH + LH Pent Panels (A5479+A5480)** onto your building as below.
Make sure the framework is flush with the wall framework.
Secure each gable with 2x **60mm Screws (A0035)**.
Note: You will have to screw at an angle to be able to fit the drill.

13

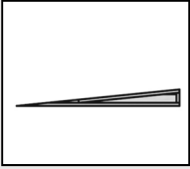

RH Pent Panel (A5479)x01

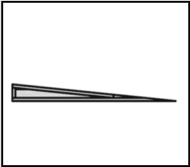

LH Pent Panel (A5480)x01

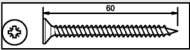

60mm Screws (A0035)x04

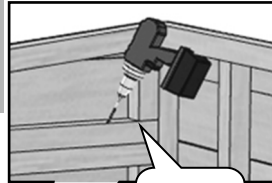
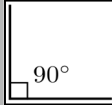

DRILL AT AN ANGLE

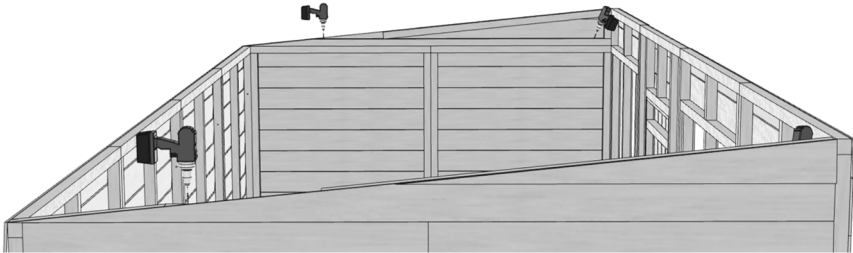

GB-IE

Use a helper to hold the **Roof Bearers 34x34 (A5482)** in place .
(the correct orientation as the timbers are angled) between the front and back panels as below.
Make sure they line up with the uprights of the wall panels and sit equally between the panel joins.
Secure each bar from the outside with 1x **60mm Screw (A0035)** in each side.

14

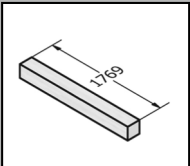

Roof Bearer 34x34 (A5482)x07

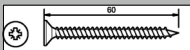

60mm Screws (A0035)x14

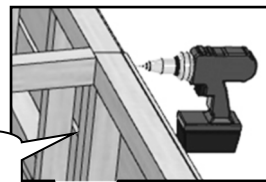
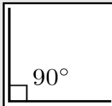

SECURE FROM THE OUTSIDE

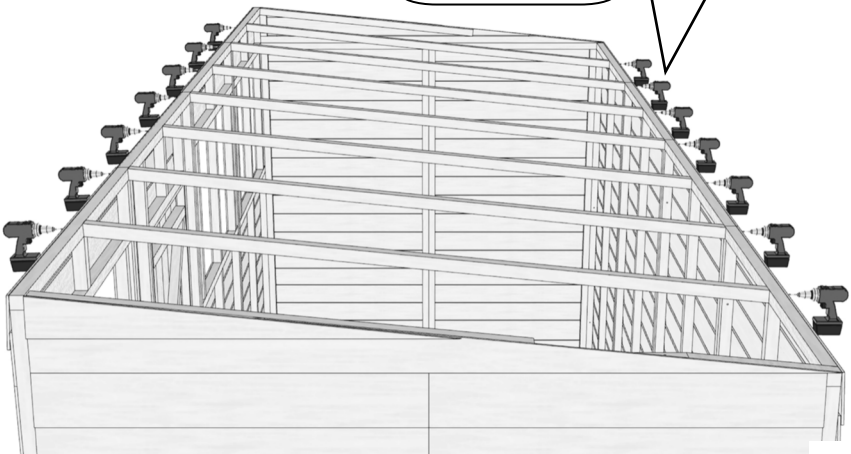

GB-IE

Nail the **Roof Edge 34x34 (A06943)** to each end of the **OSB 1220x1970 (A5481)** as below.
Nail the **34x34x1187 (A09663)** to each end of the **OSB 1187x1970 (A08571)** as below.
Secure each timber with 4x **40mm Nails (A0025)**.

Place the two **OSB 1220x1970** panels onto the outer edges of your building.
Make sure the middle gap measure **2374mm**.
Secure with 2x **40mm Nails (A0025)** along each edge and 3x **40mm Nails (A0025)** down the bearer and gable sides.
Place the two **OSB 1187x1970** in the middle as below. Secure with 2x **40mm Nails (A0025)** along each outer edge and 3x **40mm Nails (A0025)** down each side where the bearers sit.

15

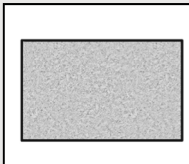

OSB 1220x1970 (A5481)x02

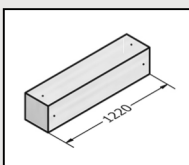

Roof Edge 34x34 (A06493)x04



OSB 1187x1970 (A08571)x02

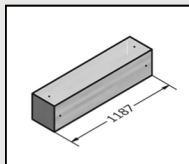

34x34x1187 (A09663)x04

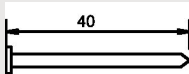

40mm Nails (A0025)x72

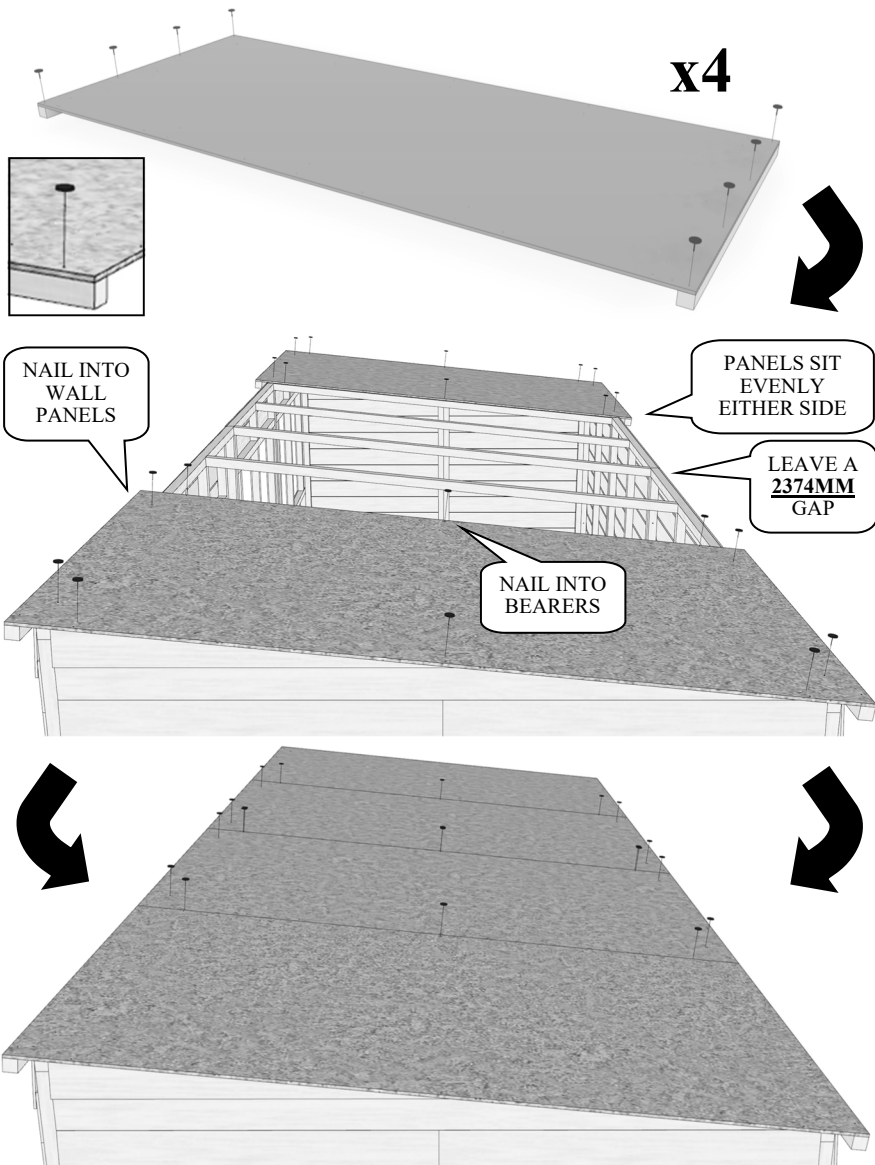

22

Make sure your building is square and true.

GB-IE Fix the walls to the floor using **60mm Screws (A0035)**.

16

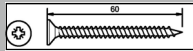

60mm Screws (A0035)x22

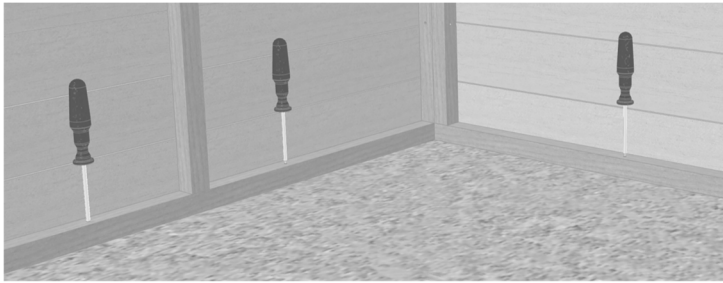
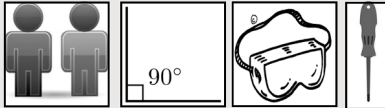

Fit the **Coverstrips 12x48x1800 (A5231)** to the lower side of your building.

Fit the **Coverstrips 12x48x1890 (A5496)** in the middle of the pent sides of your building as shown below.

Fit the **Coverstrips 12x48x1980 (A5495)** to the front of your building.

Fix with 4x **40mm Nails (A0025)** in each strip.

GB-IE

17

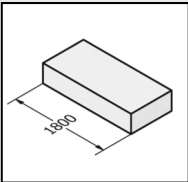
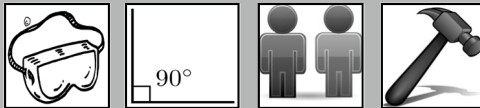

Coverstrip 12x48x1800 (A5231)x05

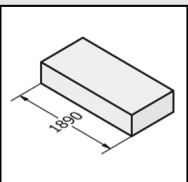

Coverstrip 12x48x1890 (A5496)x02

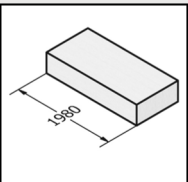

Coverstrip 12x48x1980 (A5495)x05

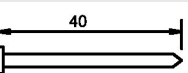

40mm Nails (A0025)x48

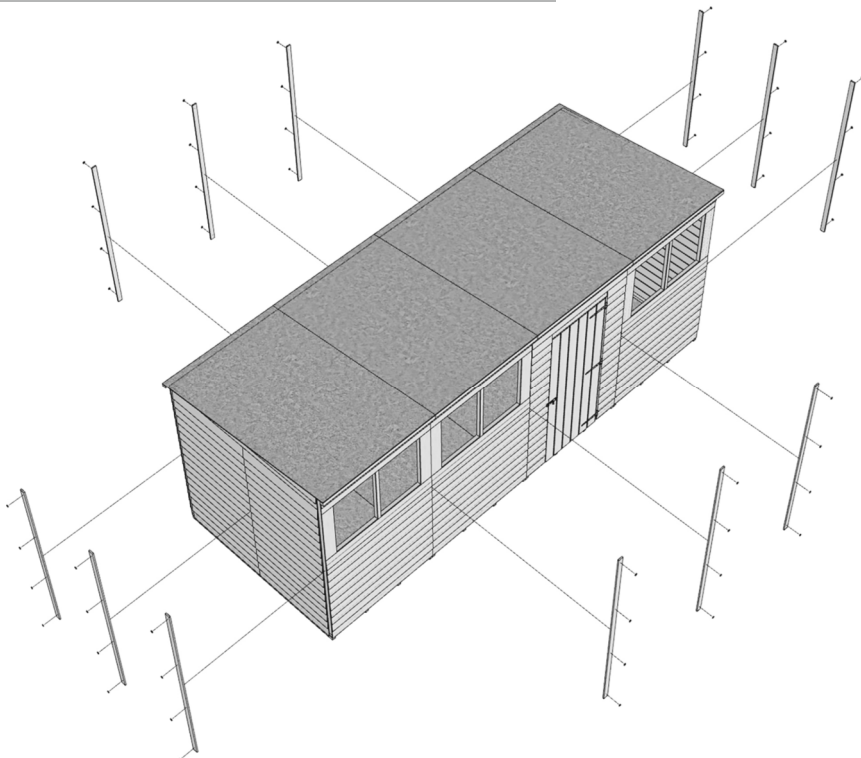

3 Strips of **Felt 5m (A06632)** have been supplied.
Fit the first piece of felt as shown below, making sure there is an even overhang front and back.
Pull the felt tight and secure with **8mm Felt Nails (A0266)** approximately **100mm** apart.
Then fit the second piece of felt, making sure it overlaps the previous as below.
Secure with **8mm Felt Nails (A0266)**.
Cut any excess felt.

18

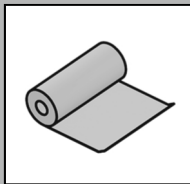

Felt Strip 5m (A06632)x02

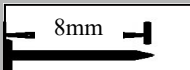

8mm Felt Nails (A0266)x134

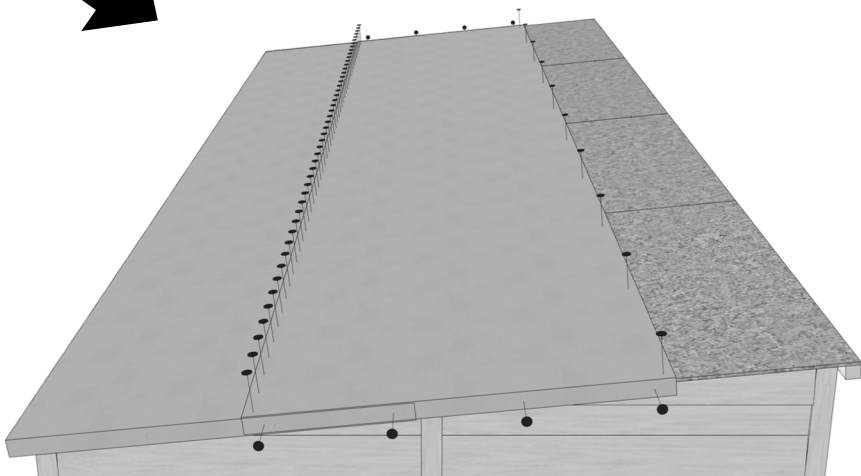
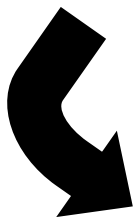
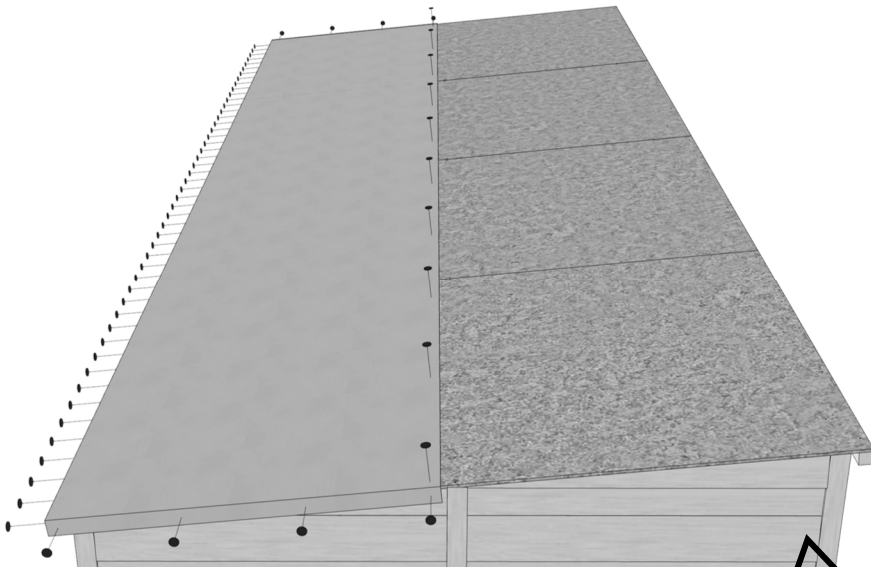

GB-IE

Fit the last strip of **Felt 5m (A06632)** as below.
Make sure it overlaps the middle felt and overhangs the sides.
Pull tight and nail with **8mm Felt Nails (A0266)** approximately **100mm** apart.
Cut any excess felt.

19

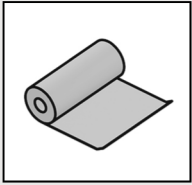

Felt Strip 5m
(A06632)x01

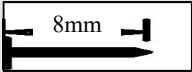

8mm Felt Nails
(A0266)x67

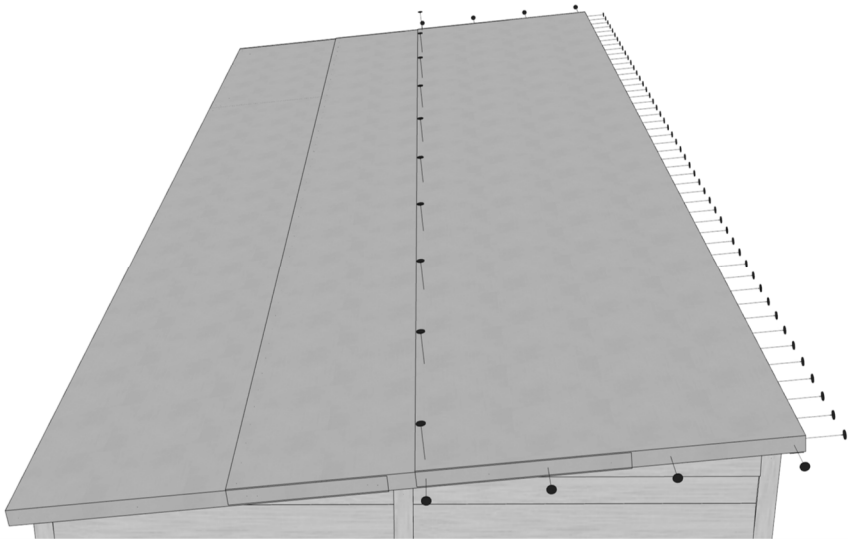

NOTE:

WOOD IS A NATURAL PRODUCT

SIZES WILL VARY +/-4MM
DEPENDING ON THE
WEATHER, TIME OF YEAR AND
HUMIDITY AS THE WOOD
EXPANDS AND CONTRACTS

Fix the **Square Fascia 12x70 (A3991)** to the building, making sure it sits evenly either side of the pent. Secure using 4x **40mm Nails (A0025)** in each as shown below.

20

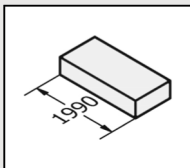

Square Fascia 12x70 (A3391)x02

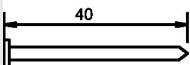

40mm Nails (A0025)x08

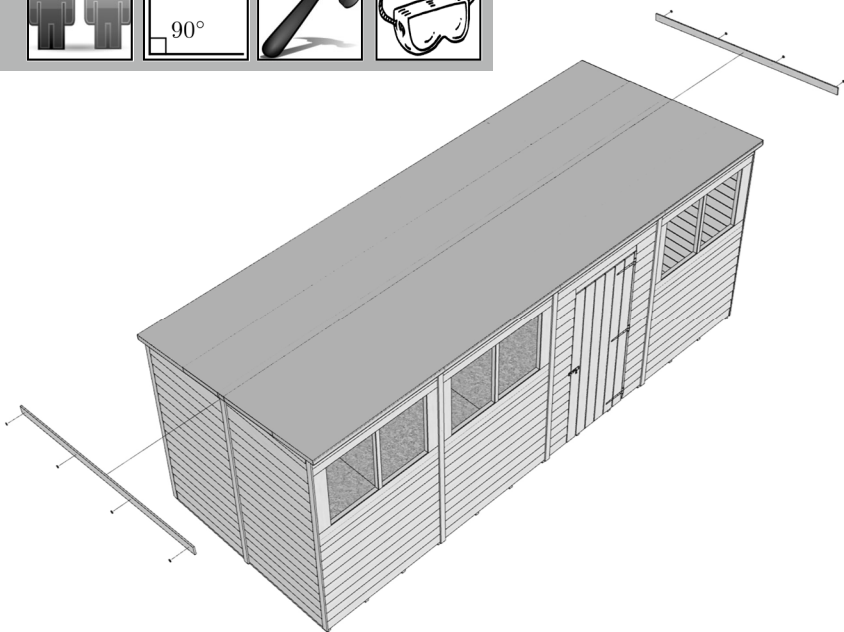

EXAMPLE OF OTHER LAYOUT

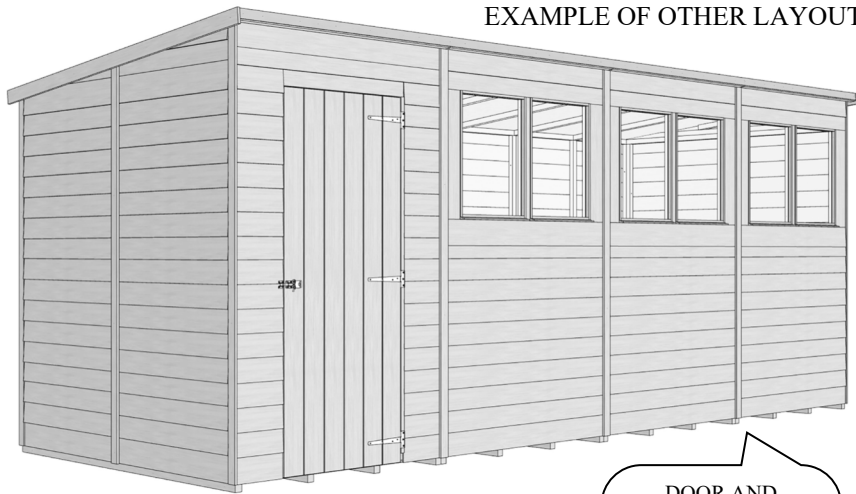

DOOR AND WINDOW PANELS CAN BE SWAPPED

DOOR CAN BE LEFT OR RIGHT HAND HUNG

GB-IE Fix the **Window Sill 460 (A1626)** to the building with 2x **40mm Nails (A0025)** as shown below. Make sure the back edge is flush with the inside framework of the Window Panel.

21

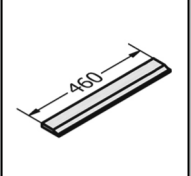

Window Sill 460 (A1626)x06

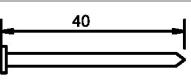

40mm Nails (A0025)x12

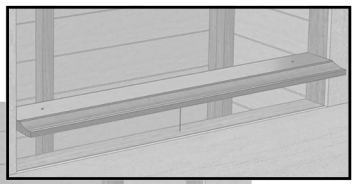

GB-IE Fix the **Window Bead 613mm (A1565)** and the **Window Bead 436mm (A1628)** so that it is flush with the inside of the window frame and nail with 2x **40mm Nails (A0025)** in each piece.

22

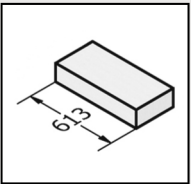

Window Bead 613mm (A1565)x12

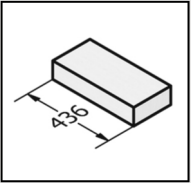

Window Bead 436mm (A1628)x12

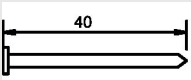

40mm Nails (A0025)x48

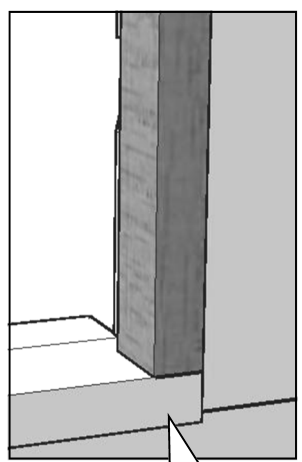
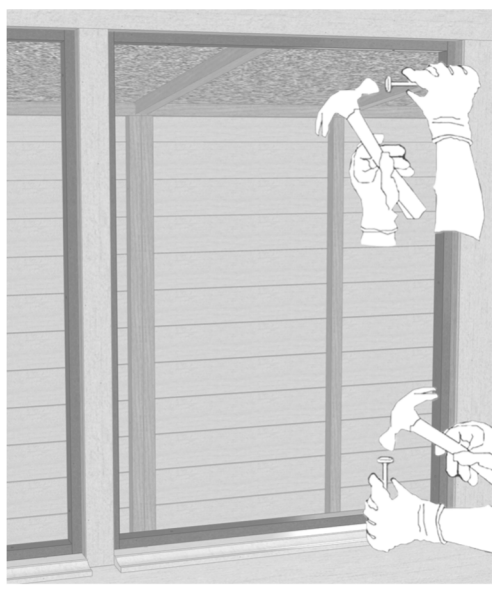

Reverse view



Fit the **Acrylic 610x457 (A5282)** as shown below.
 Whilst someone holds the glass, fit the **Window Bead 613mm (A1565)**,
 then the **Window Bead 436mm (A1628)** in front.
WEAR CORRECT SAFETY EQUIPMENT



23

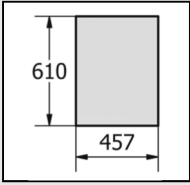

Acrylic 610x457 (A5282)x06

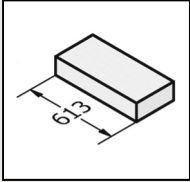

Window Bead 613mm (A1565)x12

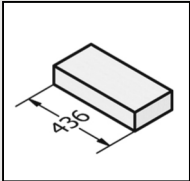

Window Bead 436mm (A1628)x12

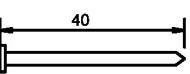

40mm Nails (A0025)x48

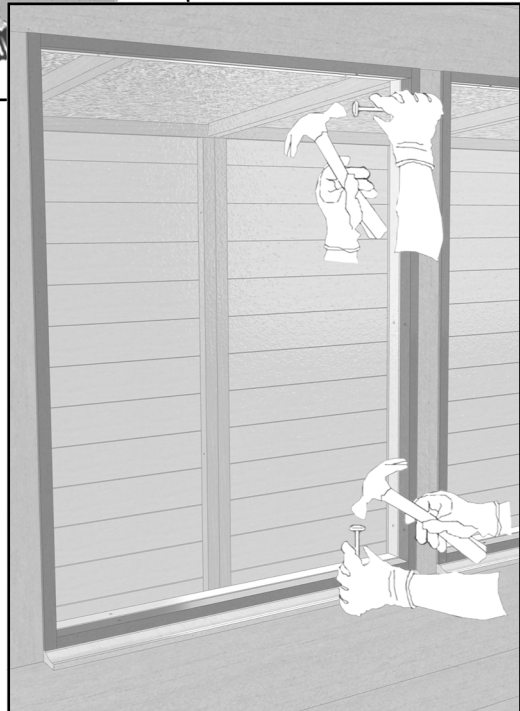
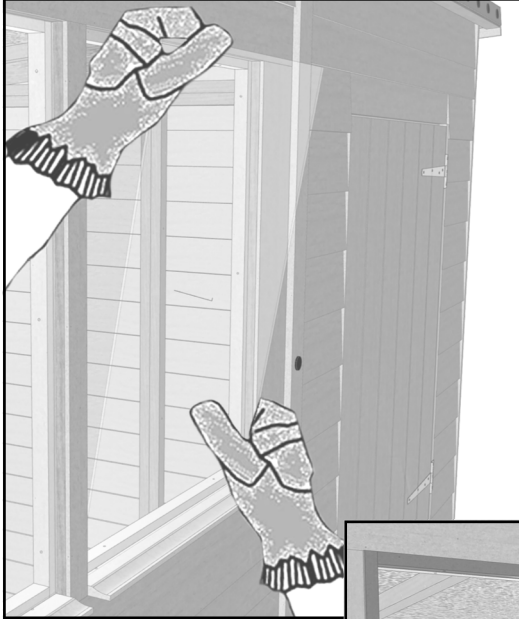

DANGER OF CUTTING HANDLE WITH CARE