

Series	Fireclay
Material	Fireclay
Installation Type	Reversible Apron Front
Configuration	Double bowl
Overall Dimensions	33" x 18" x 10 1/8"
Large Bowl Dimensions	17 1/4" x 16 1/4" x 9 1/4"
Small Bowl Dimensions	13 1/8" x 16 1/4" x 9 1/4"
Drain Size	3 3/4"
Finishes Available	Gloss White
Minimum cabinet size	33"
Template Included	No
Clips Included	No
Drain Locations	Center
Accessories Included	Strainer (x2)



ACCESSORY	
Strainer - QBSGWH	x2

Stocked Color Options



Gloss White

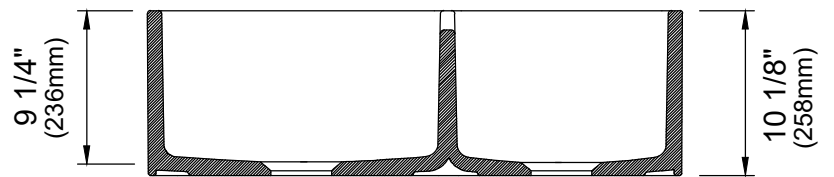
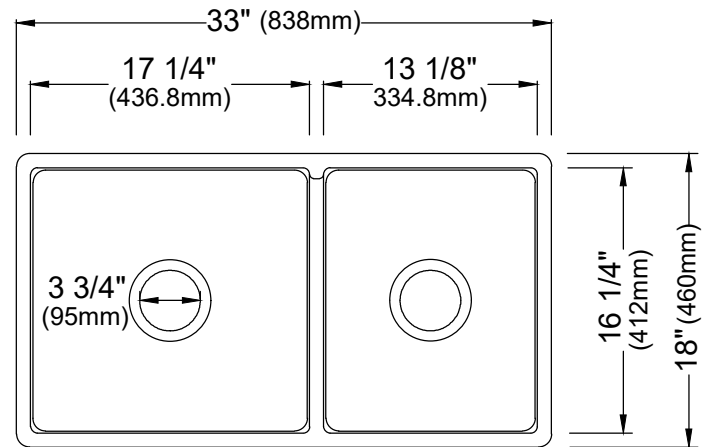

Flat Front

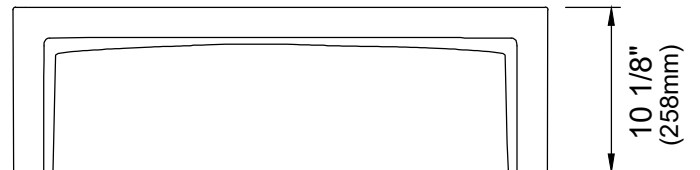

Panel Front

Listing and certifications:  
cUPC

Limited lifetime warranty

We reserve the right to update product specifications without notice. Please visit [karran.com](http://karran.com) for the most current specification sheets. All dimensions are accurate to 1/4". REV 03-2026