

STORAGE CABINET TABLES-DOUBLE

2300K, C2300K, 2400K, & C2400K SERIES
ASSEMBLY INSTRUCTIONS

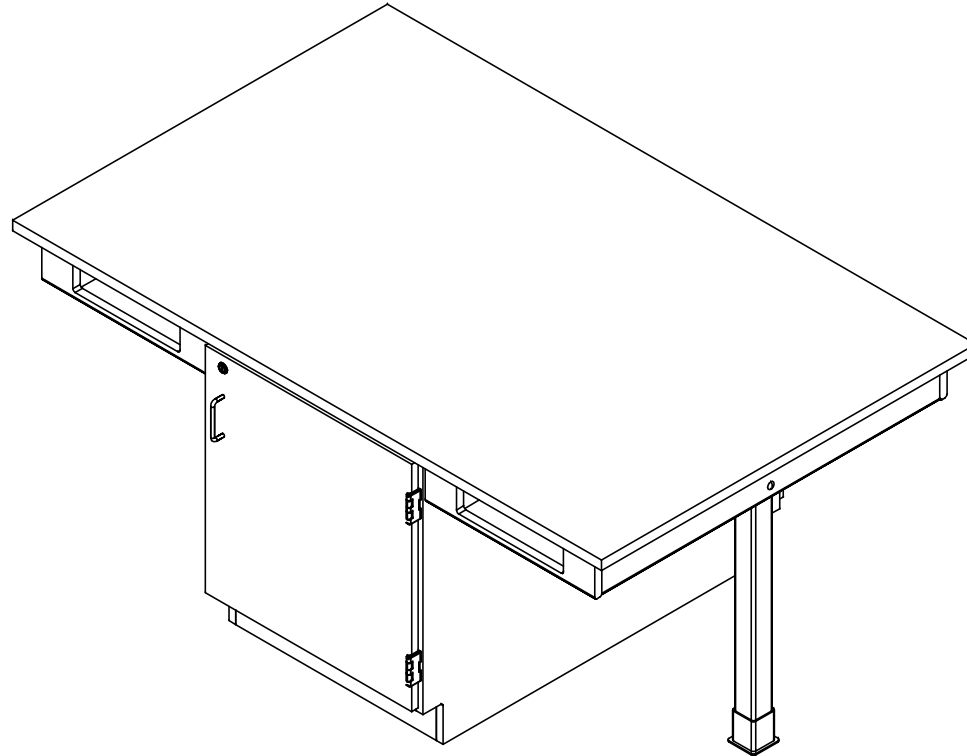

NOTE:

1. MODEL VIEWS MAY NOT REPRESENT EXACT MODEL PURCHASED

DWN BY:	EMK	DWN DATE:	3/15/16
APR BY:		DATE APR:	
APR BY:		DATE APR:	

UNLESS OTHERWISE SPECIFIED
DIMENSION ARE IN INCHES

CABINET SQUARENESS ± .0625
FRACTIONAL VALUES ± 1/32"
- ALL VALUES ± OVERALL -



300 South Krueger Street
Suring, WI 54174
diversifiedwoodcrafts.com

TITLE:
STORAGE CABINET TABLES-DOUBLE
ASSEMBLY INSTRUCTIONS

REV.	DESCRIPTION	DATE	NAME	ECN NO.
A	CREATED DRAWING	3/15/16	EMK	-

REVISION LEVEL

THIS DRAWING IS THE SOLE PROPERTY OF
DIVERSIFIED WOOD CRAFTS. IT MAY NOT
BE ALTERED OR CHANGED WITHOUT
PERMISSION

DRAWING NUMBER:	SCALE:	SHEET:	REVISION:
STORAGE CABINET TABLES	NTS	1 OF 7	REV A

TOOLS REQUIRED

1/2" WRENCH
1/2" SOCKET AND TORQUE WRENCH - OPTIONAL
CONTACT CEMENT
SCREW DRIVER
C-CLAMPS
SHIM STOCK (IF NEEDED)

ASSEMBLY COMPONENTS

ITEMS INCLUDED	PART #	PART DESCRIPTION	QTY
CABINET ASSEMBLY	VARIES	CABINET STYLES VARY WITH CHOICE OF TABLE STYLE	1
TOP AND APRON ASSEMBLY	N/A	TOP ASSEMBLY (FACTORY ASSEMBLED)	2
LEGS	500100	LEG,OAK 2.25X2.25X28.25	2
LEG HARDWARE	206618	LEG HARDWARE ASSY, BOOT,LEV,T-NUT	2
RUBBER BASE MOLDING	100283	RUBBER BASE MOLDING(SOLD BY FOOT)	10
STAINLESS STEEL CORNERS	100057	CORNERS-STAINLESS STEEL,BASE	4
SCREWS - BASE	100064	SCREW,#6X1/2 PTH SMS SS SCREW	16
CARRIAGE BOLT	100447	BOLT,5/16X4-1/2 CARRIAGE	4
HEX NUT	100044	NUT,HEX 5/16-18 STEEL ZINC	4
WASHER	100451	WASHER,5/16 FLAT ZINC PLATED	4
SILICONE	100711	SILICONE FOR TOPS	1

NOTE:

- 1. *X* INDICATES ITEMS ONLY USED FOR THE UNITS WITH EPOXY OR PHENOLIC TOPS.
- 1.1. EX: 2304K, C2304K, 2306K, C2306K, 2404K, C2404K, 2406K, & C2406K SERIES

DWN BY:	EMK	DWN DATE:	3/15/16
APR BY:		DATE APR:	
APR BY:		DATE APR:	

UNLESS OTHERWISE SPECIFIED DIMENSION ARE IN INCHES
 CABINET SQUARENESS ± .0625
 FRACTIONAL VALUES ± 1/32"
 - ALL VALUES ± OVERALL -



300 South Krueger Street
 Suring, WI 54174
 diversifiedwoodcrafts.com

TITLE:
 STORAGE CABINET TABLES-DOUBLE TOOLS AND ASSEMBLY COMPONENTS

REV.	DESCRIPTION	DATE	NAME	ECN NO.
A	CREATED DRAWING	3/15/16	EMK	-
REVISION LEVEL				

THIS DRAWING IS THE SOLE PROPERTY OF DIVERSIFIED WOOD CRAFTS. IT MAY NOT BE ALTERED OR CHANGED WITHOUT PERMISSION

DRAWING NUMBER:	SCALE:	SHEET:	REVISION:
STORAGE CABINET TABLES	NTS	2 OF 7	REV A

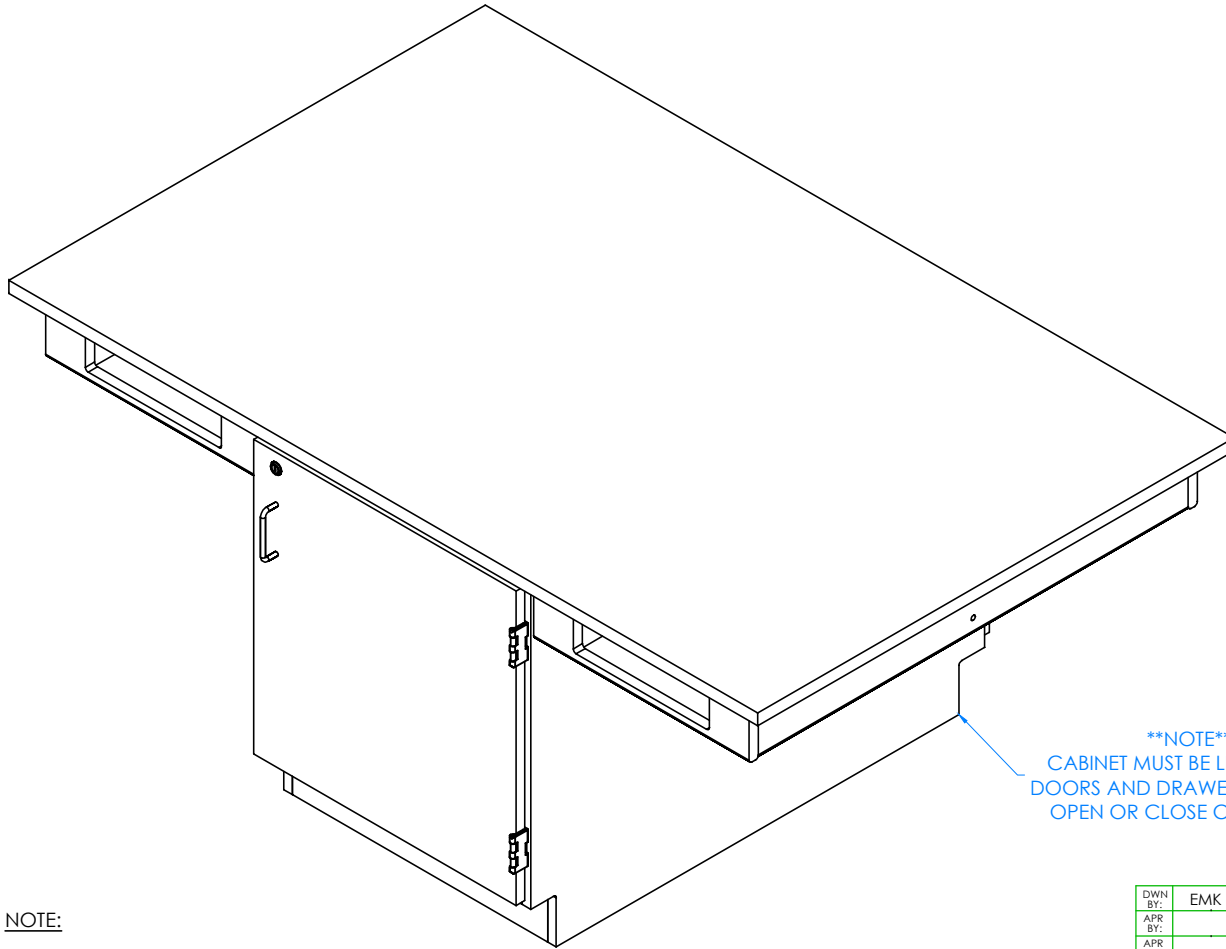

STEP 1:

- POSITION UNIT IN DESIRED LOCATION.
- LEVEL CABINET.
- ANCHOR TO FLOOR.
- YOU WILL NEED TWO OR THREE PEOPLE TO HELP WITH THIS STEP, AS TOP ASSEMBLY WILL BE HEAVY.

****NOTE****
 CABINET MUST BE LEVELED OR
 DOORS AND DRAWERS MAY NOT
 OPEN OR CLOSE CORRECTLY

NOTE:

1.

DWN BY:	EMK	DWN DATE:	3/15/16
APR BY:		DATE APR:	
APR BY:		DATE APR:	

UNLESS OTHERWISE SPECIFIED
 DIMENSION ARE IN INCHES
 CABINET SQUARENESS ± .0625
 FRACTIONAL VALUES ± 1/32"
 - ALL VALUES ± OVERALL -



300 South Krueger Street
 Suring, WI 54174
 diversifiedwoodcrafts.com

TITLE:
 STORAGE CABINET TABLES-DOUBLE
 ASSEMBLY INSTRUCTIONS

REV.	DESCRIPTION	DATE	NAME	ECN NO.
A	CREATED DRAWING	3/15/16	EMK	-
REVISION LEVEL				

THIS DRAWING IS THE SOLE PROPERTY OF
 DIVERSIFIED WOOD CRAFTS. IT MAY NOT
 BE ALTERED OR CHANGED WITHOUT
 PERMISSION

DRAWING NUMBER:	SCALE:	SHEET:	REVISION:
STORAGE CABINET TABLES	NTS	3 OF 7	REV A

STEP 2:

- LINE UP HOLES IN THE WING WITH HOLES IN THE LEG AND INSERT THE CARRIAGE BOLTS, WASHER, AND NUT.
- TIGHTEN NUT USING ½" WRENCH OR ½" SOCKET AND TORQUE WRENCH, TO A MINIMUM OF 12FT LBS BUT NOT TO EXCEED 17FT LBS.
- LEG SHOULD BE PERPENDICULAR TO THE WING.
- REPEAT FOR OTHER LEG.

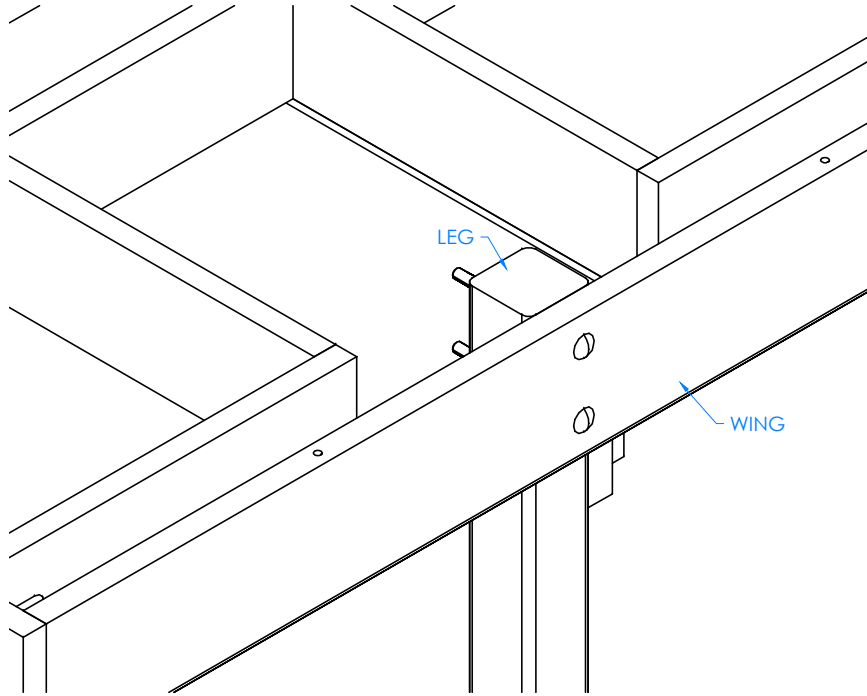

OUTSIDE OF CENTER LEG ASSEMBLY SHOWN
(TOP REMOVED TO SHOW CLARITY)

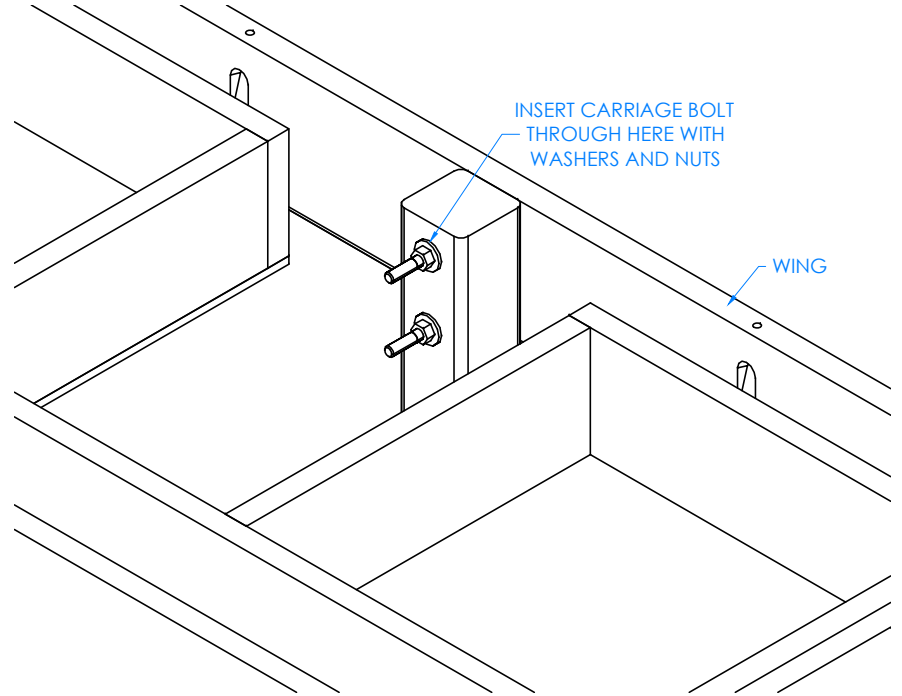

INSIDE OF CENTER LEG ASSEMBLY SHOWN
(TOP REMOVED TO SHOW CLARITY)

NOTE:

- 1.

DWN BY:	EMK	DWN DATE:	3/15/16
APR BY:		DATE APR:	
APR BY:		DATE APR:	



300 South Krueger Street
Suring, WI 54174
diversifiedwoodcrafts.com

UNLESS OTHERWISE SPECIFIED
DIMENSION ARE IN INCHES

CABINET SQUARENESS ± .0625
FRACTIONAL VALUES ± 1/32"
- ALL VALUES ± OVERALL -

THIS DRAWING IS THE SOLE PROPERTY OF
DIVERSIFIED WOOD CRAFTS. IT MAY NOT
BE ALTERED OR CHANGED WITHOUT
PERMISSION

TITLE:
STORAGE CABINET TABLES-DOUBLE
ASSEMBLY INSTRUCTIONS

REV.	DESCRIPTION	DATE	NAME	ECN NO.
A	CREATED DRAWING	3/15/16	EMK	-
REVISION LEVEL				

DRAWING NUMBER:	SCALE:	SHEET:	REVISION:
STORAGE CABINET TABLES	NTS	4 OF 7	REV A

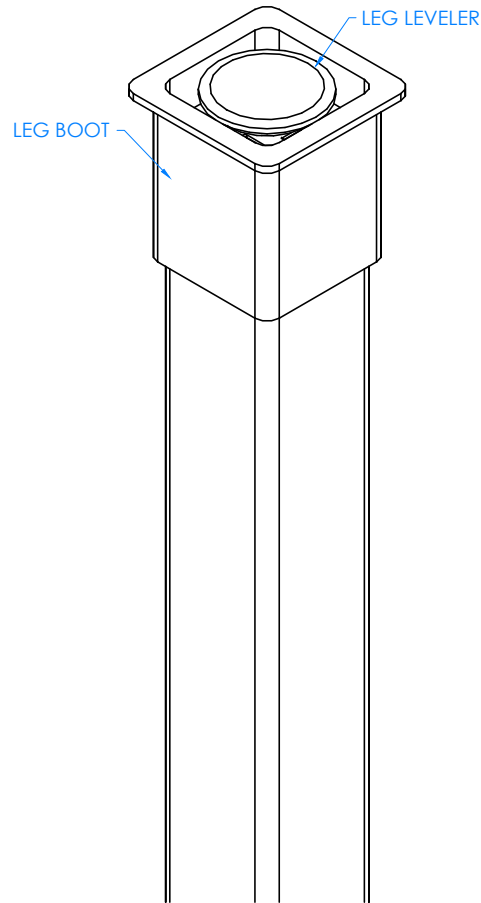

CLOSE UP OF LEG LEVELER AND LEG BOOT ASSEMBLY

STEP 3:

- SLIDE LEG BOOTS ONTO LEGS WITH FLARED END TOWARD BOTTOM OF LEGS.
- SCREW LEG LEVELERS INTO T-NUT ON BOTTOM OF LEGS.

NOTE:

1.

DWN BY:	EMK	DWN DATE:	3/15/16
APR BY:		DATE APR:	
APR BY:		DATE APR:	

UNLESS OTHERWISE SPECIFIED DIMENSION ARE IN INCHES
 CABINET SQUARENESS ± .0625
 FRACTIONAL VALUES ± 1/32"
 - ALL VALUES ± OVERALL -



300 South Krueger Street
 Suring, WI 54174
 diversifiedwoodcrafts.com

TITLE:
 STORAGE CABINET TABLES-DOUBLE
 ASSEMBLY INSTRUCTIONS

REV.	DESCRIPTION	DATE	NAME	ECN NO.
A	CREATED DRAWING	3/15/16	EMK	-

THIS DRAWING IS THE SOLE PROPERTY OF DIVERSIFIED WOOD CRAFTS. IT MAY NOT BE ALTERED OR CHANGED WITHOUT PERMISSION

DRAWING NUMBER:	SCALE:	SHEET:	REVISION:
STORAGE CABINET TABLES	NTS	5 OF 7	REV A

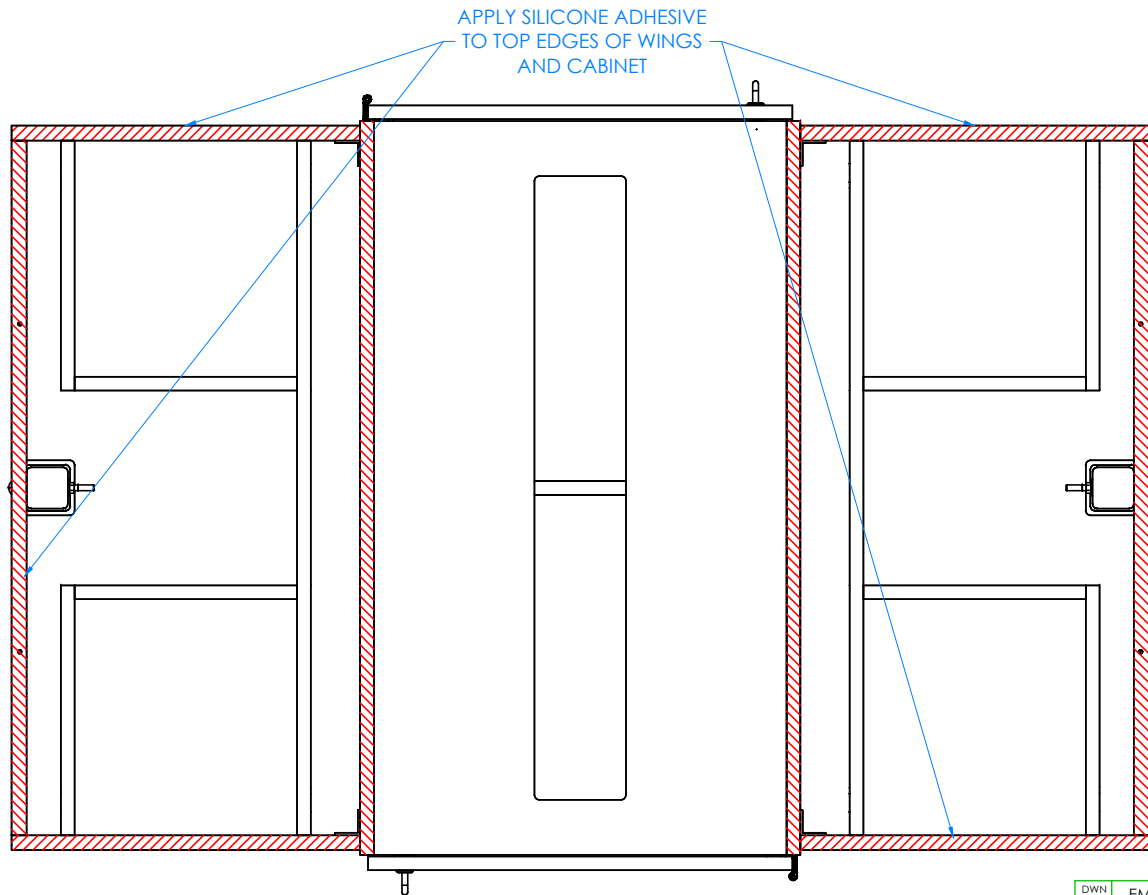

APPLY SILICONE ADHESIVE TO TOP EDGES OF WINGS AND CABINET

STEP 4:

- ADJUST LEG LEVELERS TO LEVEL TABLE.
- IF YOU **DO NOT** HAVE A PHENOLIC OR EPOXY TOP, SKIP TO STEP 5.
- APPLY SILICONE ADHESIVE TO TOP EDGES OF CABINET AND WINGS.
- PLACE TOP ON UNIT WITH PROPER OVERHANG (2" ON SIDES AND 1 1/4" ON FRONT AND BACK).
- CLAMP TOP TO WINGS AND TOP RAILS OF CABINET TO REMOVE ANY WARP USING SHIMS AND C-CLAMPS, IF NEEDED, WHEN ALIGNING TOP (DO THIS BEFORE ADHESIVE ON EDGES SETS UP).
- LET CURE FOR 6-12 HOURS.

NOTE:

- 1.

TOP VIEW OF TABLE SHOWN

DWN BY:	EMK	DWN DATE:	3/15/16
APR BY:		DATE APR:	
APR BY:		DATE APR:	

UNLESS OTHERWISE SPECIFIED DIMENSION ARE IN INCHES

CABINET SQUARENESS ± .0625
 FRACTIONAL VALUES ± 1/32"
 - ALL VALUES ± OVERALL -



300 South Krueger Street
 Suring, WI 54174
 diversifiedwoodcrafts.com

TITLE:
 STORAGE CABINET TABLES-DOUBLE
 ASSEMBLY INSTRUCTIONS

REV.	DESCRIPTION	DATE	NAME	ECN NO.
A	CREATED DRAWING	3/15/16	EMK	-
REVISION LEVEL				

THIS DRAWING IS THE SOLE PROPERTY OF
 DIVERSIFIED WOOD CRAFTS. IT MAY NOT
 BE ALTERED OR CHANGED WITHOUT
 PERMISSION

DRAWING NUMBER:	SCALE:	SHEET:	REVISION:
STORAGE CABINET TABLES	NTS	6 OF 7	REV A

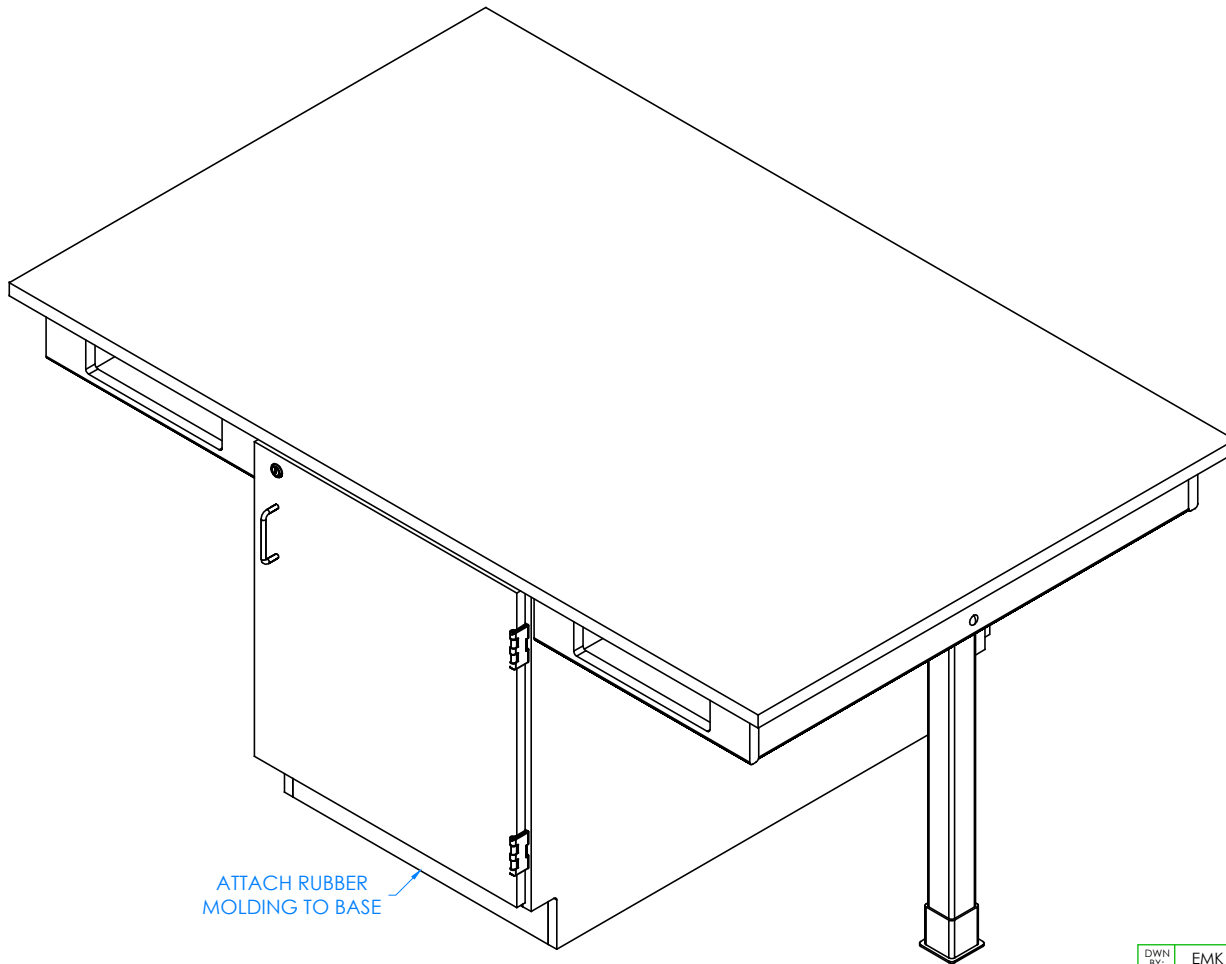

STEP 5:

- ATTACH RUBBER MOLDING TO BASE OF CABINET USING CONTACT CEMENT.
- SCREW STAINLESS STEEL CORNER BRACKETS ON EACH CORNER OVER BASE MOLDING WITH HARDWARE PROVIDED.

ATTACH RUBBER MOLDING TO BASE

NOTE:

- 1.

COMPLETE UNIT SHOWN

DWN BY:	EMK	DWN DATE:	3/15/16
APR BY:		DATE APR:	
APR BY:		DATE APR:	

UNLESS OTHERWISE SPECIFIED DIMENSION ARE IN INCHES
 CABINET SQUARENESS ± .0625
 FRACTIONAL VALUES ± 1/32"
 - ALL VALUES ± OVERALL -



300 South Krueger Street
 Suring, WI 54174
 diversifiedwoodcrafts.com

TITLE:
 STORAGE CABINET TABLES-DOUBLE
 ASSEMBLY INSTRUCTIONS

REV.	DESCRIPTION	DATE	NAME	ECN NO.
A	CREATED DRAWING	3/15/16	EMK	-
REVISION LEVEL				

THIS DRAWING IS THE SOLE PROPERTY OF DIVERSIFIED WOOD CRAFTS. IT MAY NOT BE ALTERED OR CHANGED WITHOUT PERMISSION

DRAWING NUMBER:	SCALE:	SHEET:	REVISION:
STORAGE CABINET TABLES	NTS	7 OF 7	REV A