

# Assembly Instructions

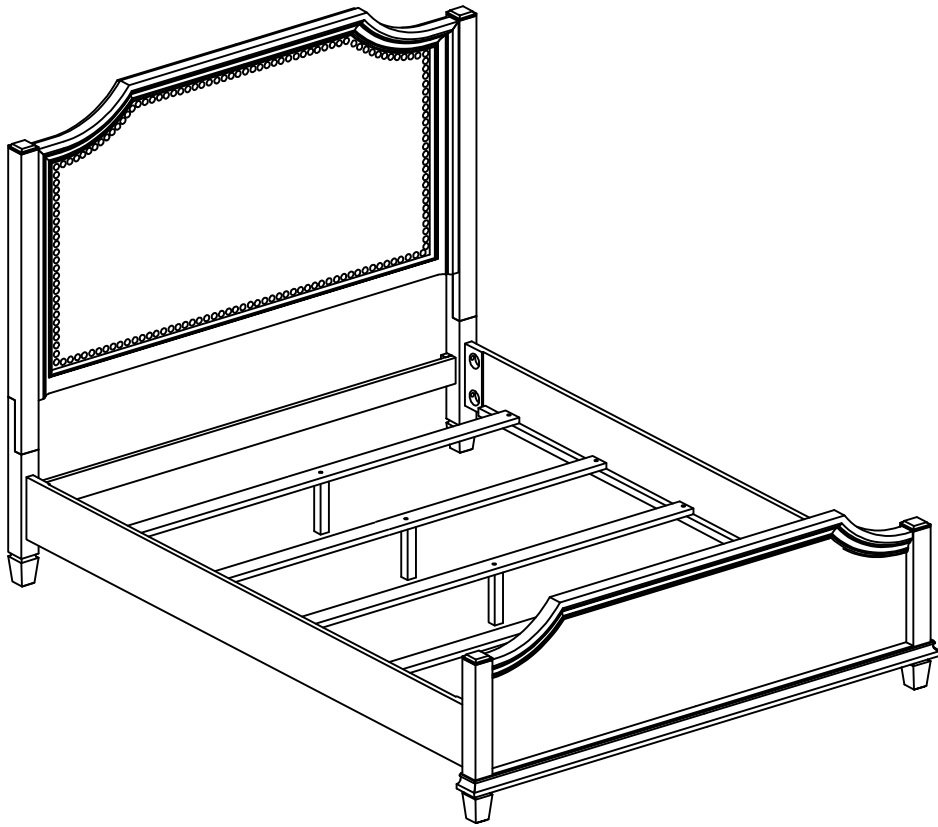

## ASSEMBLY RATING

The Assembly Rating is a 5-point system that shows the degree of effort needed in assembling a specific product (with 1 being easy and 5 being difficult). For some products, two persons are recommended.

EASY



DIFFICULT

## Tools Required For Assembly:

Allen Wrench

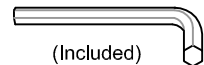

(Included)

Phillips Screwdriver



(Not Included)

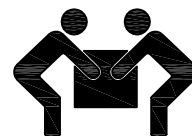

2 PERSONS RECOMMENDED

# ASSEMBLY & CARE ADVICE

FOR YOUR FURNITURE TO LAST, CORRECT ASSEMBLY AND PROPER MAINTENANCE ARE NECESSARY. PLEASE FOLLOW THE INFORMATION PROVIDED BELOW TO FULLY ENJOY YOUR FURNITURE.

## BASIC ASSEMBLY TECHNIQUES

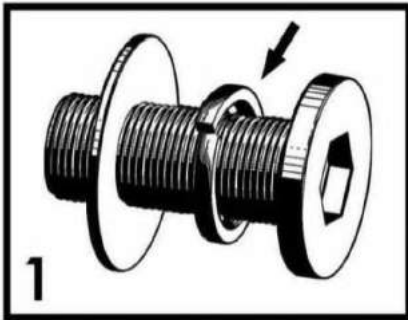

When lock or spring washer is used in an assembly, please make sure the lock or spring washer is placed between the larger flat washer and the head of the screw or bolt.

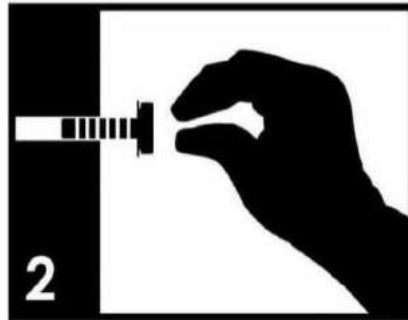

Position each part correctly and insert screws or bolts into their respective holes by hand tighten or using the proper hand tool. Only tighten when step is completed or when instructed to do so.

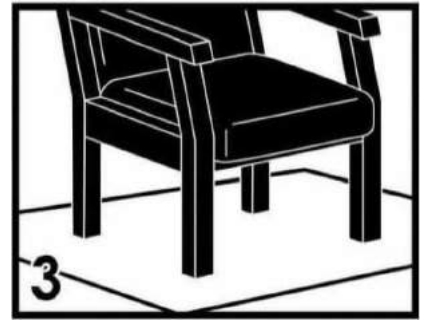

Use cardboard or carpet area when assembling furniture to prevent scratches. Make sure the furniture rests on a flat and level surface with each leg evenly touching the floor.

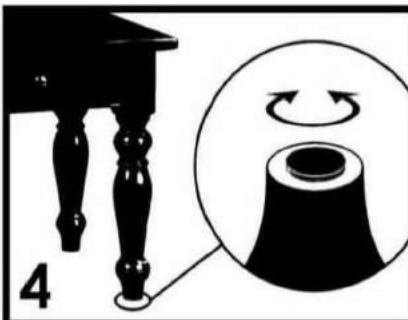

Some furniture comes with height adjustment knobs underneath each leg. To lower or to raise each leg, you need to turn clockwise or counterclockwise, respectively.

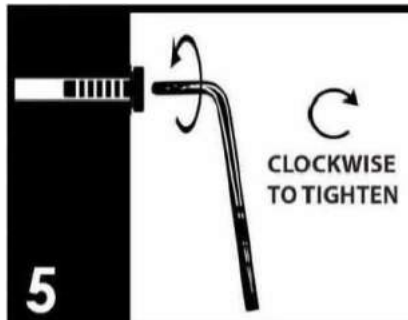

Make sure all parts are properly aligned, then use the appropriate hand tool to completely tighten the bolts or screws. Do not use power tools and do not overtighten.

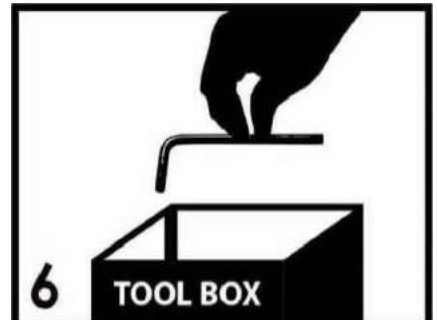

Save the instructions and store the Allen wrench or any supplied tool for later maintenance. After two weeks, check and tighten any loose hardware and repeat again every six months thereafter.

IT IS THE USER'S RESPONSIBILITY TO MAINTAIN THE FURNITURE. THE HARDWARE MAY LOOSEN OVER TIME AND MAY CAUSE THE FURNITURE TO BE WOBBLY AND UNABLE TO SUPPORT ITS INTENDED WEIGHT CAPACITY. THIS MAY LEAD TO COLLAPSE AND MAY CAUSE SERIOUS INJURY.

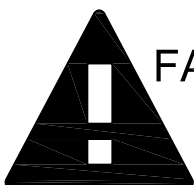

**FAILURE TO FOLLOW THE GUIDELINES ABOVE MAY RESULT IN INJURY AND/OR PROPERTY DAMAGE.**











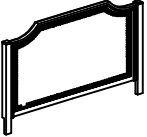



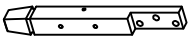

Before you begin, please read Page 2 of "Assembly and Care Advice".

And remember, do not tighten until each step is completed or instructed.

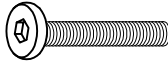
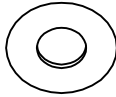
### Parts List

### Hardware List

-  #1 x 1pc  
Headboard
-  #2 x 1pc  
Footboard
-  #3 x 2pcs  
Side Rail
-  #4 x 1pc  
Headboard Leg Support
-  #5 x 2pcs  
Leg L/R
-  #6 x 5pcs  
Slat
-  #7 x 5pcs  
Slat Support Leg
-  #L x 10pcs  
Wood screws(1/4X30)

-  #A x 8pcs  
Bolt 5/16 x 2"
-  #B x 8pcs  
Flat Washer(Ø5/16)
-  #C x 8pcs  
Lock Washer(Ø5/16)
-  #D x 8pcs  
Hanger Bolt(Ø5/16x75)
-  #E x 8pcs  
Side Rail Bracket
-  #F x 8pcs  
Hex Nut (Ø 5/16 x 6)
-  #G x 1pc  
Allen Wrench
-  #H x 1pc  
Wrench



- I. Carefully place the headboard (#1) onto a protected surface.
- II. Align the legs (#5R/L) to the pre-drilled holes located on the back of the headboard (#1). As you align the legs, align the headboard leg support (#4) to the pre-drilled holes along the sides of the legs.
- III. Prepare 8 bolt assemblies by FIRST inserting the lock washer (#C) onto the bolt (#A) then the flat washer (#B) onto that SAME bolt (#A), in that order. Insert 3 bolt assemblies into each leg and one on each end of the leg support. Secure using the Allen wrench (#G).

#A x 8 pcs  
#B x 8 pcs  
#C x 8 pcs

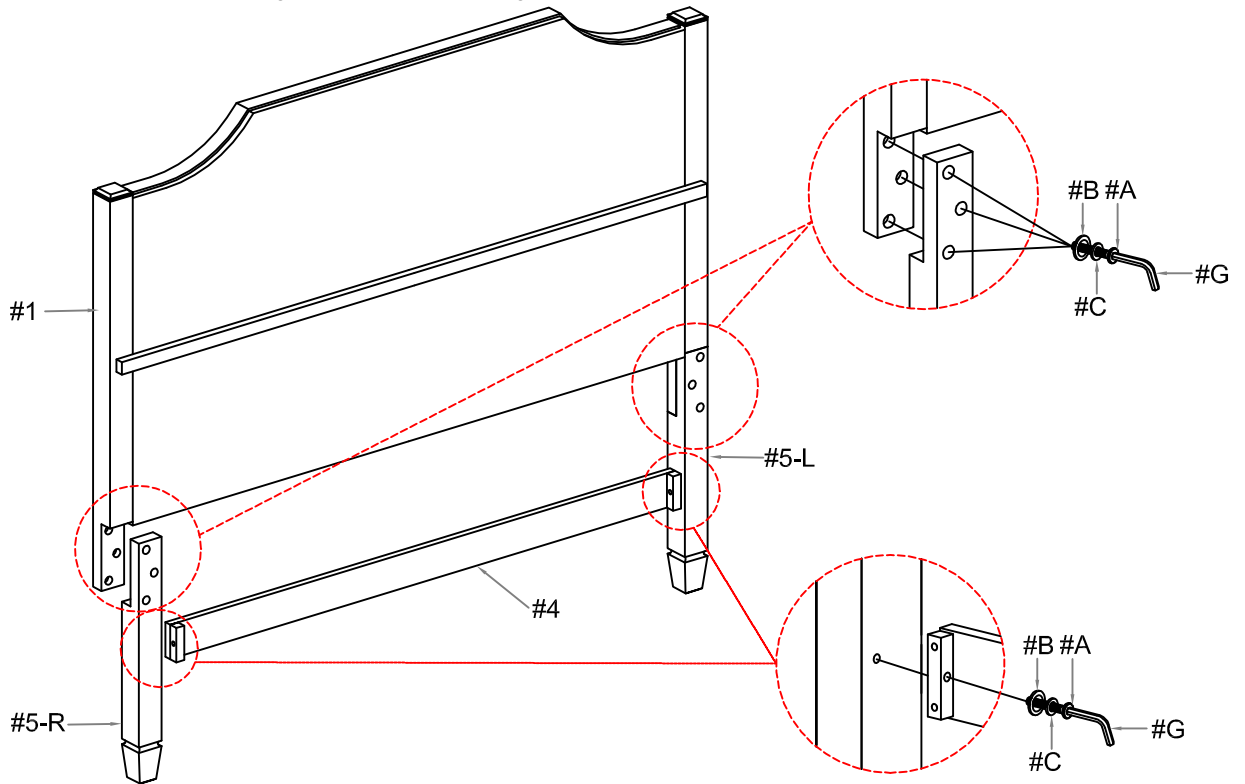

- I. Insert 2 hanger bolts (#D) into each the headboard legs and footboard ends (#2). Turn right to tighten.
- II. Insert the the other ends of the hanger bolts (#D) into the pre-drilled holes on the ends of the side rails (#3).
- III. From within the side rails (#3) insert a side rail bracket (#E) and then a hex nut (#F) onto the hanger bolts. Secure using the wrench (#H).

#D x 8 pcs  
#E x 8 pcs  
#F x 8 pcs

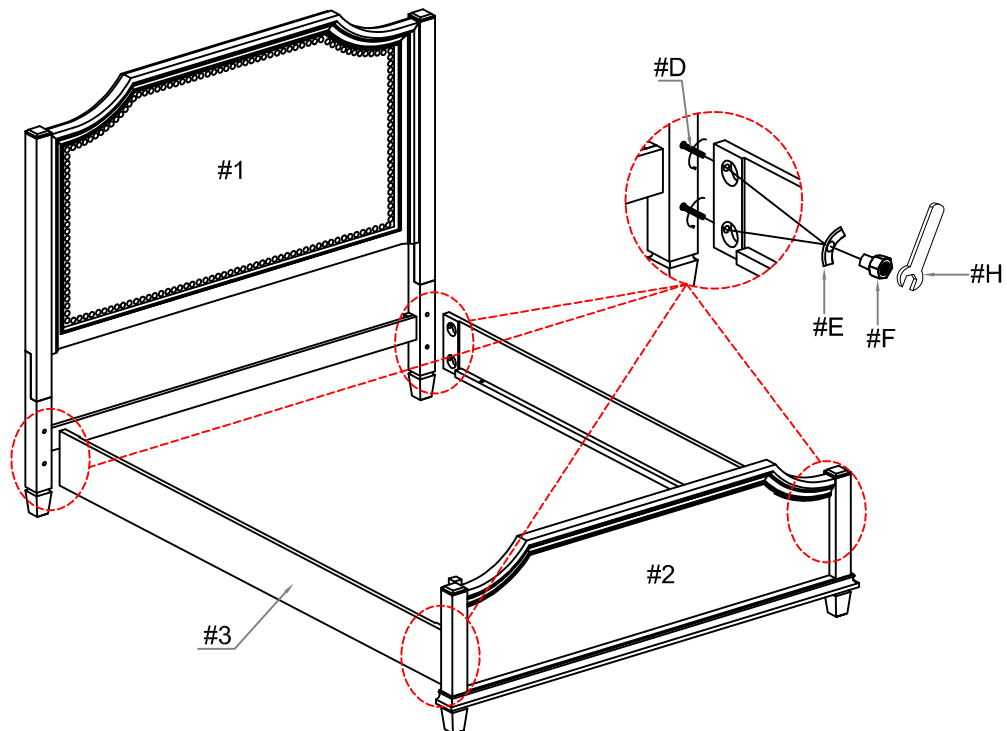



Insert the threaded ends of the slat support legs (#7) into the pre-drilled hole on each slat (#6). Turn right to tighten and level to ground.

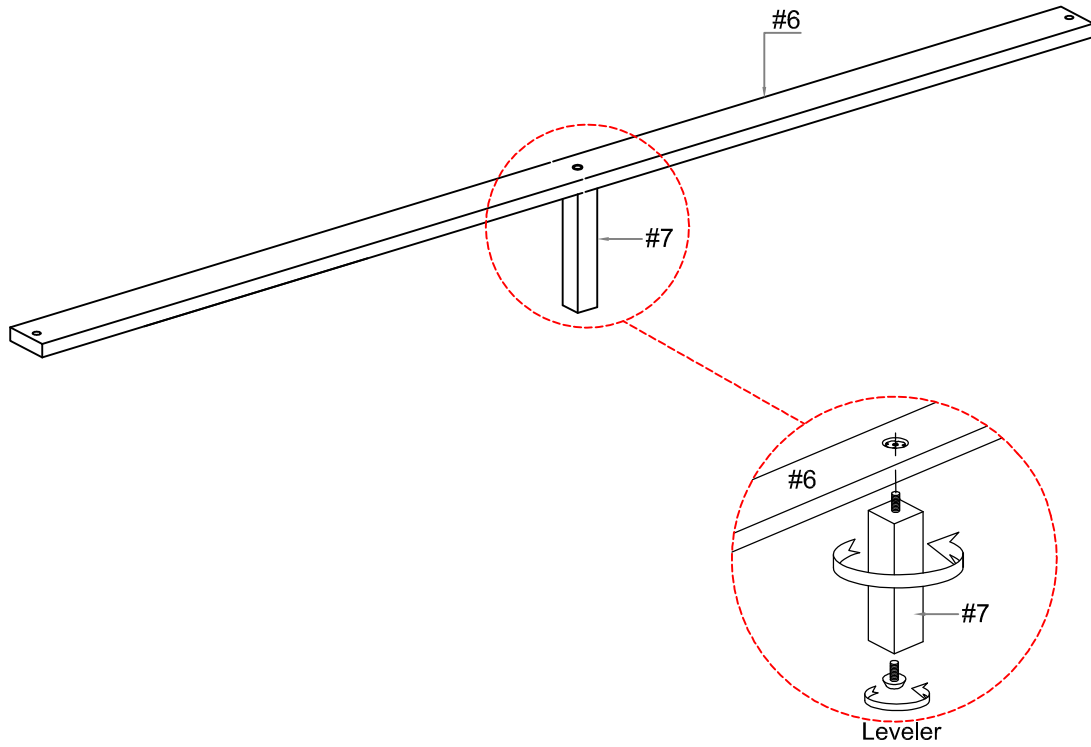

Align the ends of the slats (#6) to the pre-drilled holes along the sides of the side rails (#3). Insert a screw (#L) into each end and secure using a Phillips screwdriver.

#L x 10 pcs

