

# ASSEMBLY INSTRUCTIONS

INSTRUCTIONS DE MONTAGE

## FULL / FULL BUNK BED WITH STAIR

LIT SUPERPOSÉ COMPLET AVEC ESCALIER

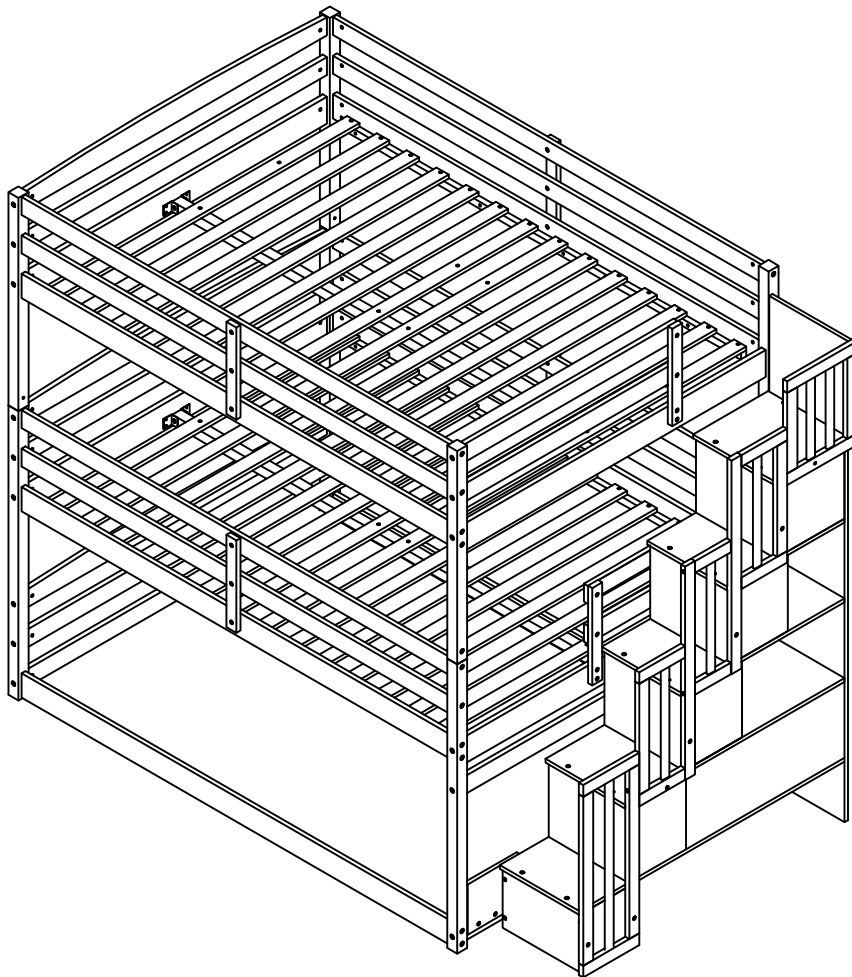

## SAFETY WARNINGS AND GENERAL NOTES:

Follow the information on the warnings on the bunk bed end structure and on the carton. Do not remove the warning label from the bed. Always use the recommended size mattress on mattress support, or both, to help prevent the likelihood of entrapment or falls.

The top surface of the mattress must be at least 5\*inch (127mm) below the upper edge of the guardrail.

Do not allow children under 6 years of age to use the upper bunk.

Periodically check and ensure the guardrail, ladder and other components are in their proper position, free from damage, and all connectors are tight.

Do not allow horseplay on or under beds.

Always prohibit jumping on the bed.

Prohibit more than one person on upper bunk.

Always use the ladder for entering and leaving the upper bunk.

Do not use substitute parts. Contact the manufacturer or dealer for replacement parts.

Use of a night-tight may provide added safety precaution for a child using the upper bunk.

Always use guardrails on both long sides of the upper bunk.

If the bunk bed will be placed next to a wall, the guardrail that runs the full length of the bed should be placed against the wall to prevent entrapment between the bed and the wall.

The use of water or sleep flotation mattresses is prohibited.

**STRANGULATION HAZARD**-Never attach or hang items to any part of the bunk bed that are not designed for use with the bed.

Keep these instructions for future reference.

We recommend assembling your bunk bed on the shipping carton to protect your floor or carpet.

Be certain all staples are out of the box before beginning assembly on the shipping carton.

**USE ONLY MATTRESSES WHICH ARE 74"-75" LONG AND 54" WIDE ON UPPER AND ON LOWER BUNKS. ENSURE THICKNESS OF MATTRESS DOES NOT EXCEED 6".**

**SURFACE OF MATTRESS MUST BE AT LEAST 5" (127MM) BELOW THE UPPER EDGE OF GUARDRAILS.**

Replacement Parts:

Replacement Parts, including additional guardrails, may be obtained from any of our dealers.

## AVERTISSEMENTS DE SÉCURITÉ ET REMARQUES GÉNÉRALES :

Suivez les informations sur les avertissements figurant sur la structure d'extrémité du lit superposé et sur le carton. Ne retirez pas l'étiquette d'avertissement du lit.

Utilisez toujours le matelas de taille recommandée sur le support de matelas, ou les deux, pour éviter tout risque de coincement ou de chute.

La surface supérieure du matelas doit être à au moins 5\*poûces (127 mm) sous le bord supérieur du garde-corps.

Ne laissez pas les enfants de moins de 6 ans utiliser le lit supérieur.

Vérifiez périodiquement et assurez-vous que le garde-corps, l'échelle et les autres composants sont dans leur bonne position, exempts de dommages et que tous les connecteurs sont bien serrés.

Ne permettez pas les chahuts sur ou sous les lits.

Interdisez toujours de sauter sur le lit.

Interdire plus d'une personne sur la couchette supérieure.

Utilisez toujours l'échelle pour entrer et sortir du lit supérieur.

N'utilisez pas de pièces de rechange. Contactez le fabricant ou le revendeur pour obtenir des pièces de rechange.

L'utilisation d'une veilleuse peut fournir une précaution supplémentaire en matière de sécurité pour un enfant utilisant le lit supérieur.

Utilisez toujours des garde-corps sur les deux côtés longs du lit supérieur.

Si le lit superposé doit être placé à côté d'un mur, le garde-corps qui s'étend sur toute la longueur du lit doit être placé contre le mur pour éviter tout coincement entre le lit et le mur.

L'utilisation de matelas flottants à eau ou de sommeil est interdite.

**RISQUE D'ÉTRANGULATION** - N'attachez ou ne suspendez jamais d'objets à une partie du lit superposé qui ne sont pas conçus pour être utilisés avec le lit.

Conservez ces instructions pour référence future.

Nous vous recommandons d'assembler votre lit superposé sur le carton d'expédition pour protéger votre sol ou votre tapis.

Assurez-vous que toutes les agrafes sont sorties de la boîte avant de commencer l'assemblage sur le carton d'expédition.

**CE LIT EST CONÇU POUR UTILISER UN MATELAS JUMELLES DE 54" DE LARGE X 74"-75" DE LONG AVEC L'ÉPAISSEUR TOTALE NE DÉPASSANT PAS 6" POUR LE COUCHE SUPÉRIEUR, POUR LA PLEINE TAILLE INFÉRIEURE DEVRAIT ÊTRE 54" DE LARGE X 74"-75 " LONG, LARGE AVEC 6" D'ÉPAISSEUR. LA SURFACE DU MATELAS DOIT ÊTRE À AU MOINS 5" (127 MM) EN DESSOUS DU BORD SUPÉRIEUR DES GARDE-CORPS.**

Pièces de rechange :

Les pièces de rechange, y compris les garde-corps supplémentaires, peuvent être obtenues auprès de l'un de nos revendeurs concessionnaires.





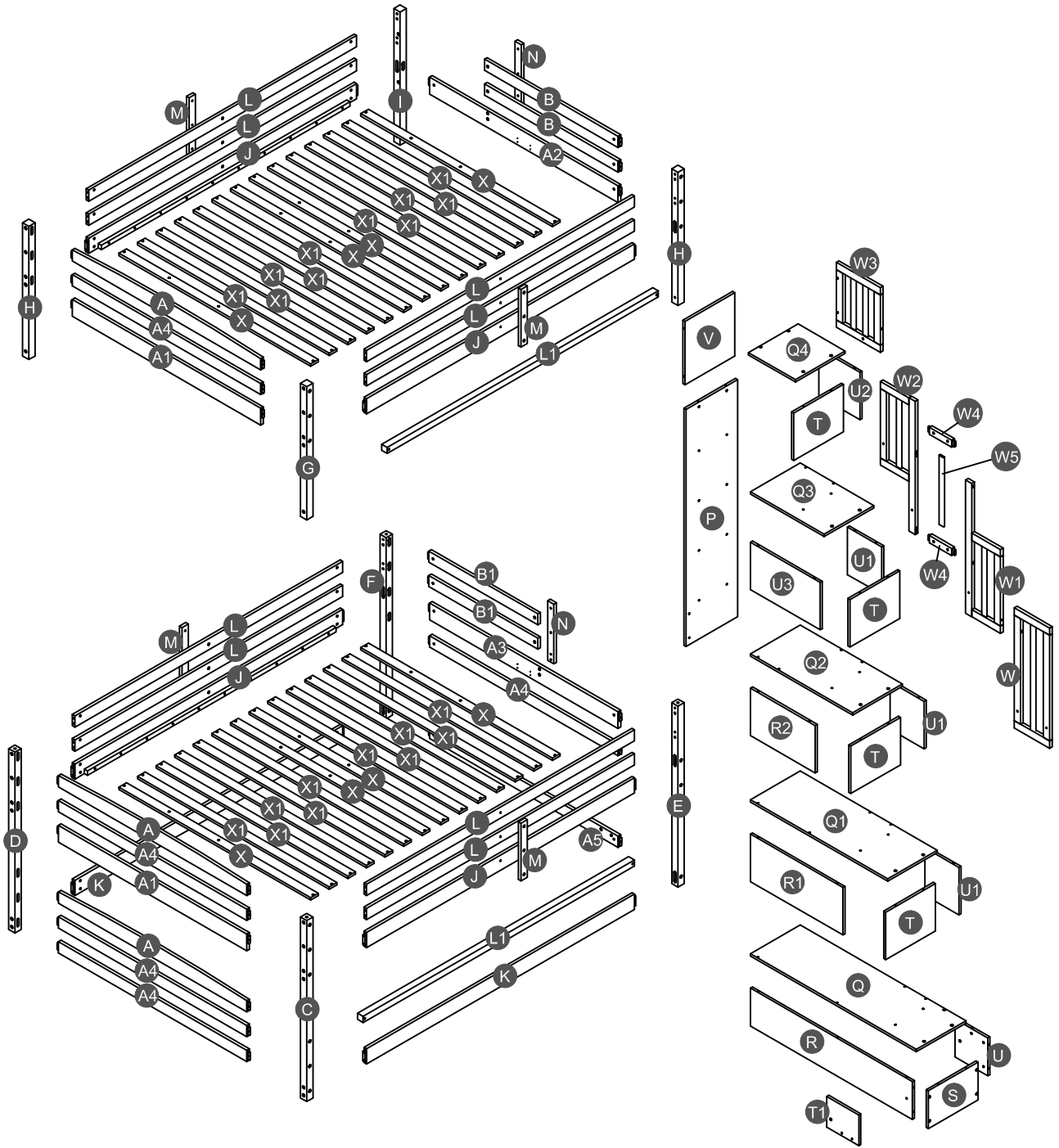

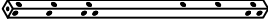
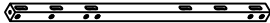

# Detail View

## Vue Détaillée

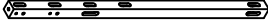

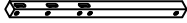
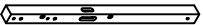

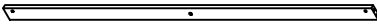
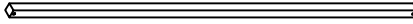







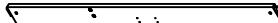
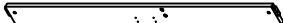
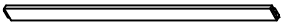

## Part list (Box 1)

Liste des pièces (Boîte 1)

<b>C</b>  Lower leg (Left Front) - 1pc Inférieure pied (Avant gauche)	<b>D</b>  Lower leg (Left Back) - 1pc Inférieure pied (Arrière gauche)	<b>E</b>  Lower leg (Right Front) - 1pc Inférieure pied (Avant droit)
<b>F</b>  Lower leg (Right Back) - 1pc Inférieure pied (Arrière droit)	<b>G</b>  Upper leg (Left Front) - 1pc Supérieure pied (Avant gauche)	<b>H</b>  Upper leg (Left Back/Right Front) - 2pcs Supérieure pied (Arrière gauche/Avant droit)
<b>I</b>  Upper leg (Right Back) - 1pc Supérieure pied (Arrière droit)	<b>J</b>  Lower & upper side rail - 4pcs Rail latéral inférieur et supérieur	<b>K</b>  Lower side rail - 2pcs Rail latéral inférieur
<b>L</b>  Long guard rail - 8pcs Garde-corps long	<b>L1</b>  Lower support slat - 2pcs Latte de support inférieure	<b>X1</b>  Slats - 7pcs Lattes





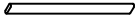
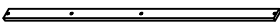
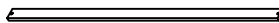





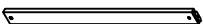
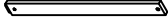



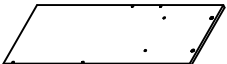

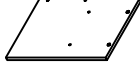
## Part list & Hardware list (Box 2)

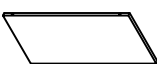
Liste des pièces & liste du matériel (Boîte 2)

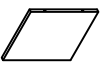
<b>A</b>  Horizontal bar HB - 3pcs Barre horizontale HB	<b>A1</b>  Horizontal bar HB - 2pcs Barre horizontale HB	<b>A2</b>  Horizontal bar FB - 1pc Barre horizontale FB
<b>A3</b>  Horizontal bar FB - 1pc Barre horizontale FB	<b>A4</b>  Horizontal bar FB/HB - 5pcs Barre horizontale FB	<b>A5</b>  Horizontal bar FB - 1pc Barre horizontale FB
<b>R</b>  Lower left side panel - 1pc Panneau latéral inférieur gauche	<b>S</b>  Lower front panel - 1pc Panneau avant inférieur	<b>U</b>  Lower right side panel - 1pc Panneau latéral inférieur droit
<b>V</b>  Upper back panel - 1pc Panneau arrière supérieur	<b>W</b>  Lower guard side - 1pc Côté protection inférieure	<b>W1</b>  Guard side - 1pc Côté garde
<b>W2</b>  Guard side - 1pc Côté garde	<b>W3</b>  Upper guard side - 1pc Côté garde supérieur	<b>W4</b>  Guard side - 2pcs Côté garde
<b>W5</b>  Guard bar - 1pc Barre de garde	<b>X</b>  Slats - 4pcs Lattes	<b>X1</b>  Slats - 10pcs Lattes

## Part list (Box 3)

Liste des pièces (Boîte 3)

<b>B</b>  Upper horizontal bar FB - 2pcs Barre horizontale supérieure FB	<b>B1</b>  Lower horizontal bar FB - 2pcs Barre horizontale inférieure FB	<b>M</b>  Vertical guard rail - 4pcs Garde-corps vertical
<b>N</b>  Vertical guard rail - 2pcs Garde-corps vertical	<b>P</b>  Back panel - 1pc Panneau arrière	<b>Q</b>  Lower step ladder panel -1pc Panneau d'échelle inférieur
<b>Q1</b>  Lower center step ladder panel -1pc Panneau d'échelle central inférieur	<b>Q2</b>  Lower center step ladder panel -1pc Panneau d'échelle central inférieur	<b>Q3</b>  Lower center step ladder panel -1pc Panneau d'échelle central inférieur
<b>Q4</b>  Upper step ladder panel -1pc Panneau d'échelle supérieur	<b>R1</b>  Center side panel - 1pc Panneau latéral central	<b>R2</b>  Upper left side panel -1pc Panneau latéral supérieur gauche
<b>T</b>  Center front panel - 4pcs Panneau avant central	<b>T1</b>  Support - 1pc Support	<b>U1</b>  Lower center side panel - 3pcs Panneau latéral central inférieur
<b>U2</b>  Upper right side panel - 1pc Panneau latéral supérieur droit	<b>U3</b>  Upper left side panel - 1pc Panneau latéral supérieur gauche	<b>X</b>  Slats - 4pcs Lattes
<b>X1</b>  Slats - 3pcs Lattes		

## Hardware List (Box 2 )

Liste du matériel (Boîte 2 )

<b>1</b>	 Ø8*30mm Wood dowel (31pcs) Cheville en bois	<b>2</b>	 (Ø15)1/4"*100mm Hex-Head bolts (40pcs) Boulons à tête hexagonale	<b>3</b>	 (Ø15)1/4"*80mm Hex-Head bolts (32pcs) Boulons à tête hexagonale
<b>4</b>	 (Ø12)1/4"*70mm Hex-Head bolts (4pcs) Boulons à tête hexagonale	<b>5</b>	 (Ø12)1/4"*60mm Hex-Head bolts (45pcs) Boulons à tête hexagonale	<b>6</b>	 (Ø12)1/4"*40mm Hex-Head bolts (8pcs) Boulons à tête hexagonale
<b>7</b>	 (Ø12)1/4"*30mm Hex-Head bolts (24pcs) Boulons à tête hexagonale	<b>8</b>	 1/4"*15 (9.5mm) Horizontal-Hole bolts(119pcs) Boulons à trou horizontal	<b>9</b>	 (Ø10)1/4*76mm Connecting bar (4pcs) Barre de connexion
<b>10</b>	 Ø3.5*15mm Wood screws (24pcs) Vis	<b>11</b>	 (1/4")4.5*58mm Allen key (2pcs) Clé Allen	<b>12</b>	 Ø4*30mm Wood screws (68pcs) Vis
<b>13</b>	 (Ø12)1/4"*40mm Hex-Head bolts (1pc) Boulons à tête hexagonale	<b>14</b>	 Ø10*40mm Wood dowel (16pcs) Cheville en bois	<b>15</b>	 50*24*24*2mm Metal bracket (2pcs) Support métallique
<b>16</b>	 Ø9*32mm Plastic anchor (2pcs) Ancrage en plastique	<b>17</b>	 58*16*16*(1.5mm) Metal bracket (2pcs) Support métallique	<b>18</b>	 Ø4*38mm Screws (2pcs) Vis
<b>19</b>	 (Ø13)1/4"*14mm Connect bolt (4pcs) Connecter le boulon	<b>20</b>	 116*40*27mm Metal bracket (4pcs) Support métallique		



**ASSEMBLY TOOLS REQUIRED ( NOT INCLUDED )**

OUTILS D'ASSEMBLAGE REQUIS (NON INCLUS)

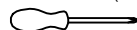

( Phillip head screwdriver )

**PLEASE BE CAREFUL DO NOT DAMAGE THE HOLE POSITION WHEN YOU USE POWER TOOLS !**

NE PAS UTILISER DES OUTILS ÉLECTRIQUES POUR ASSEMBLER CE PRODUIT !

# STEP 1:

ÉTAPE

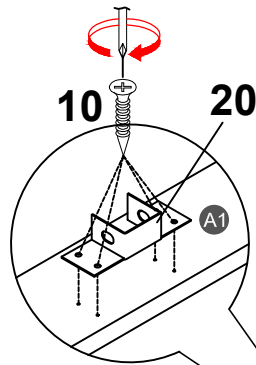

3		8		10		20	
<b>12PCS</b>		<b>12PCS</b>		<b>4PCS</b>		<b>1PC</b>	

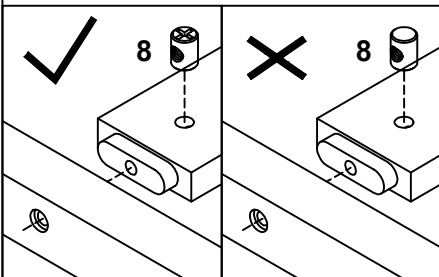
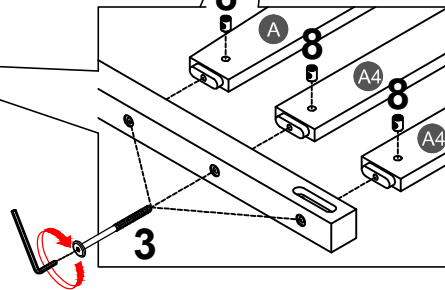
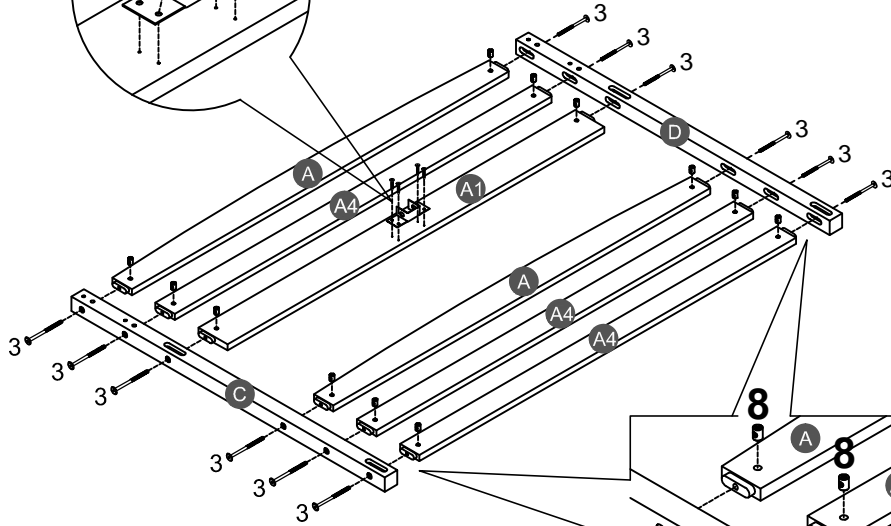

Note: Part 8 will face up with the "x" mark on it, otherwise it cannot be tightened

Remarque: La pièce 8 sera face vers le haut avec la marque "x", sinon elle ne peut pas être serrée.

# STEP 2:



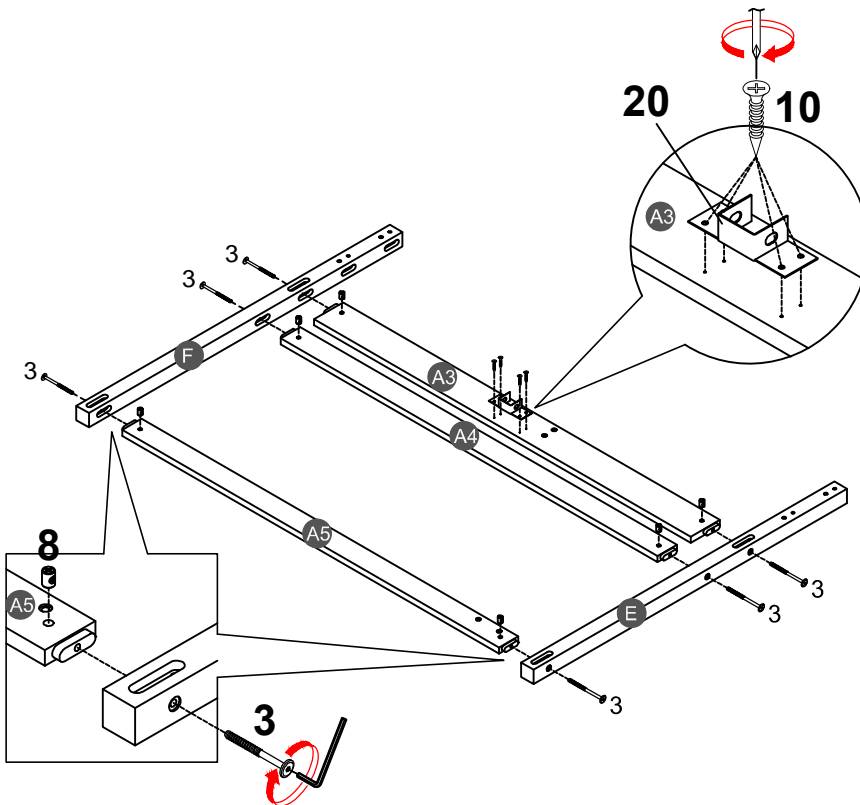

ÉTAPE



3		<b>6PCS</b>
8		<b>6PCS</b>
10		<b>4PCS</b>
20		<b>1PC</b>

# STEP 3:

ÉTAPE

14		2		8		9	
8PCS		24PCS		24PCS		4PCS	

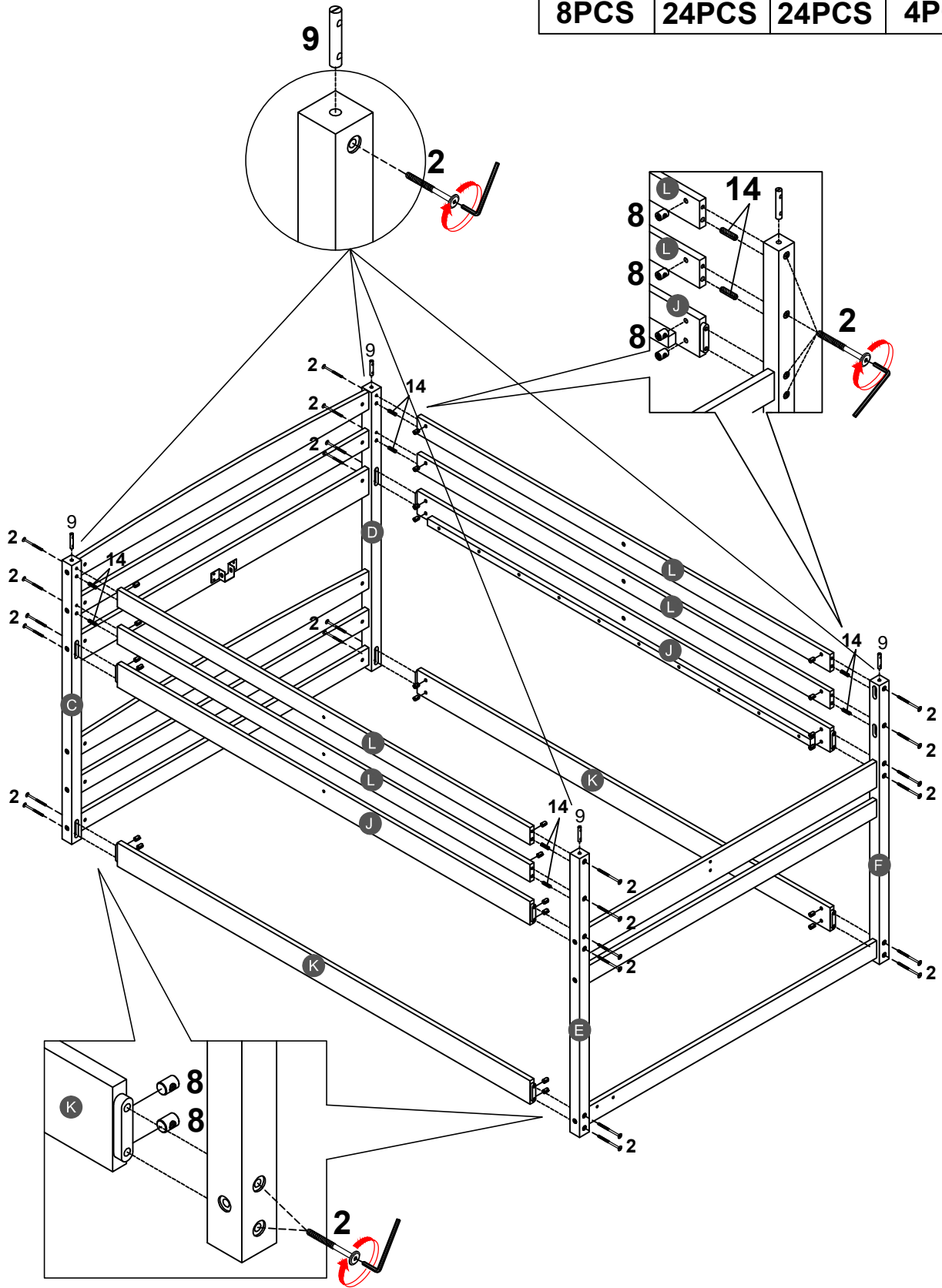

# STEP 4:

ÉTAPE

7



6PCS

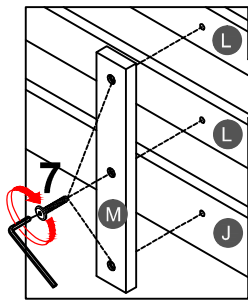
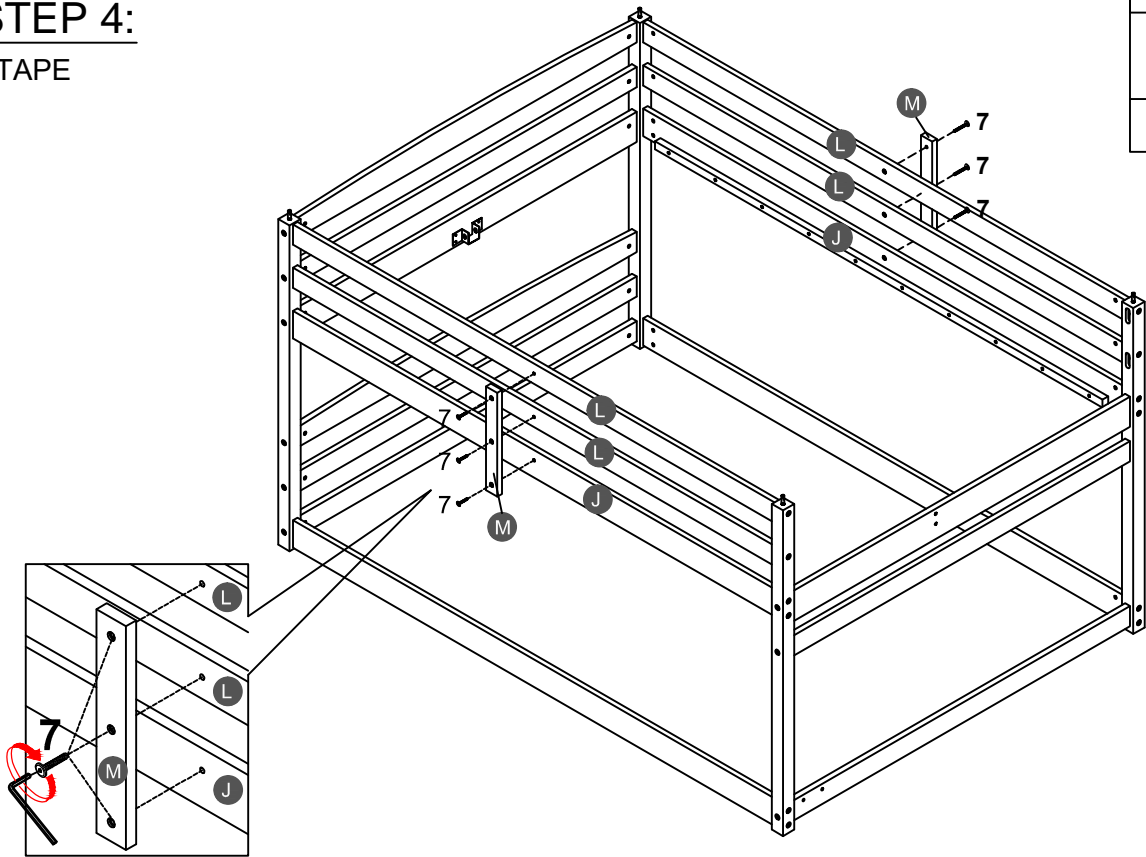

# STEP 5:

ÉTAPE

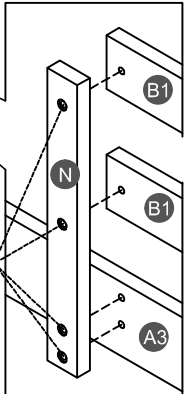
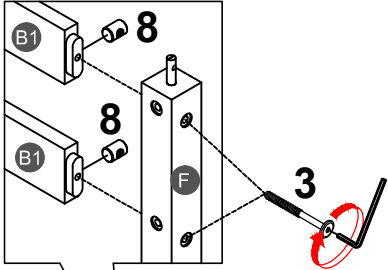
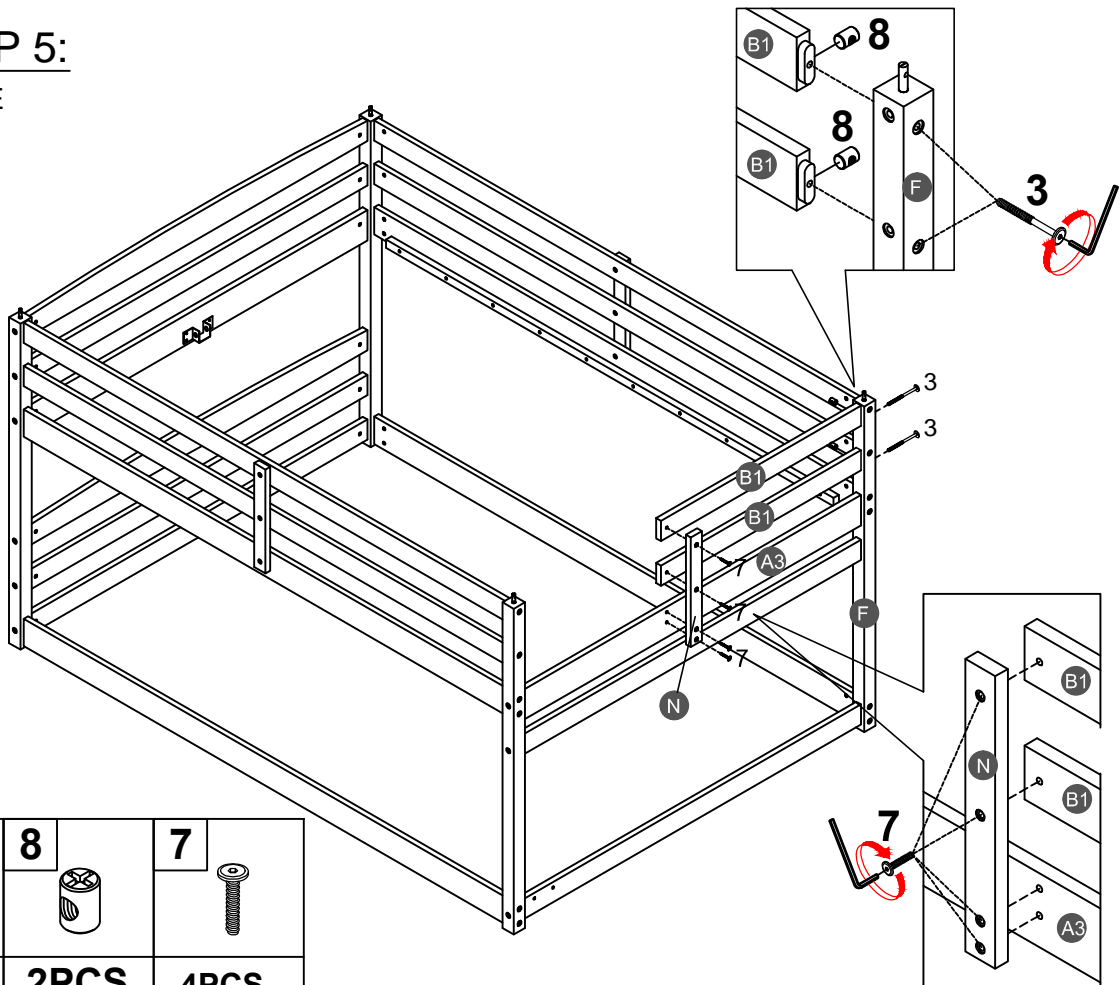

3



2PCS

8



2PCS

7



4PCS

## STEP 6:

ÉTAPE

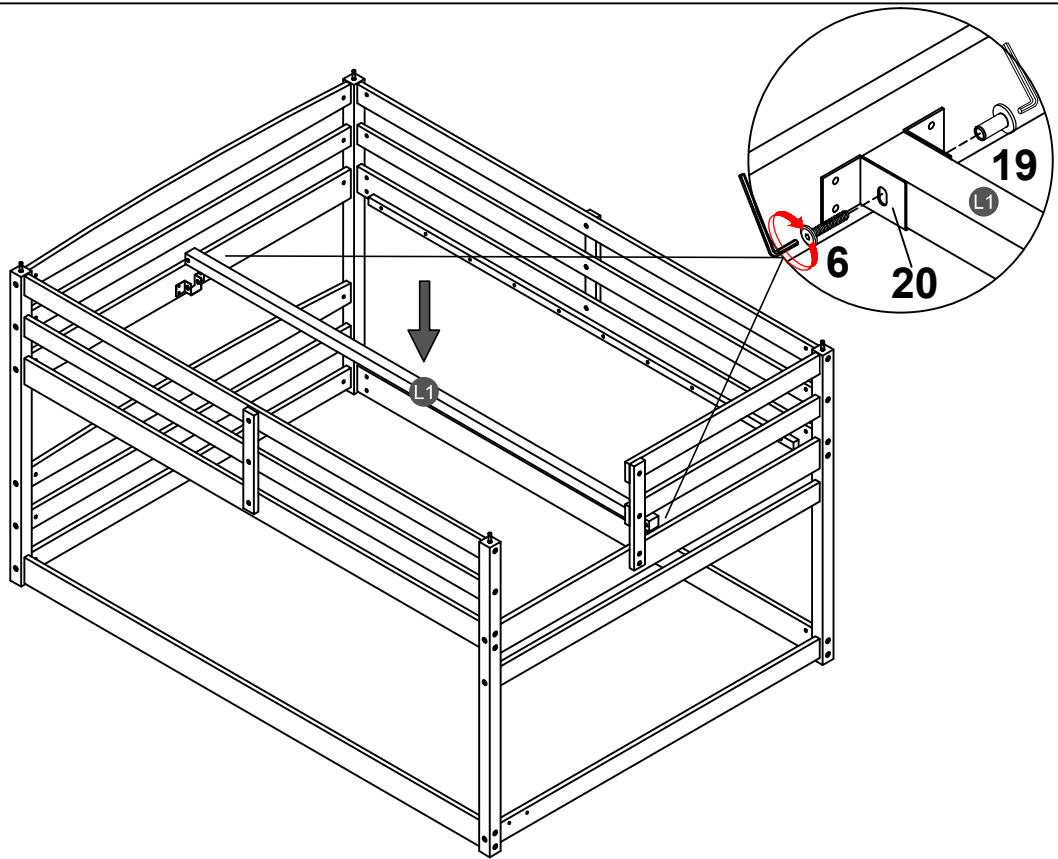

6



2PCS

19



2PCS

## STEP 7:

ÉTAPE

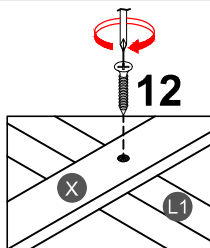

12



32PCS

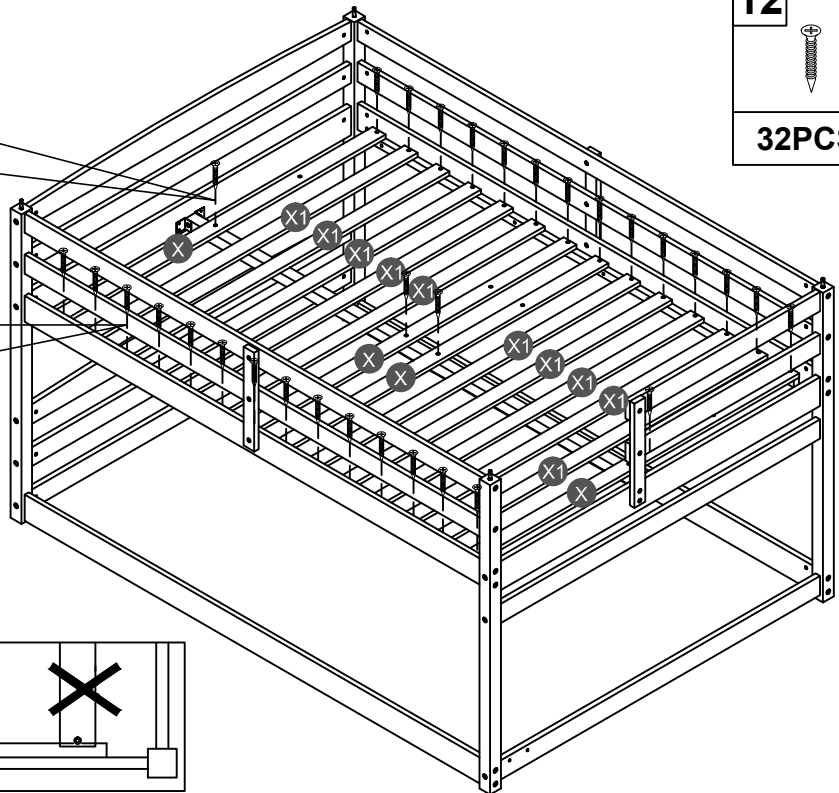
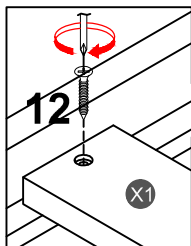

3.1" 3.3" 2.4"  
79mm 84.5mm 61mm

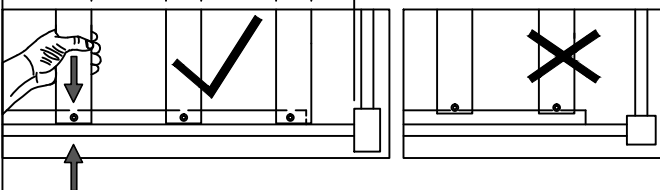

**NOTE:** Please make sure the bed slats close to the side rail before locking the screws to avoid breakage. This step is required for both the left and right sides. Moreover, please do not lock the screws of the bed slats at the outermost edge to avoid damaging.

**Remarque:** Assurez-vous Les lattes du lit fermer du rail latéral avant de verrouiller les vis pour éviter la casse. Cette étape est requise pour tous les deux côtés gauche et droit. De plus, ne verrouillez pas les vis des lattes de lit sur le bord le plus extérieur pour éviter d'endommager.

# STEP 8:

ÉTAPE

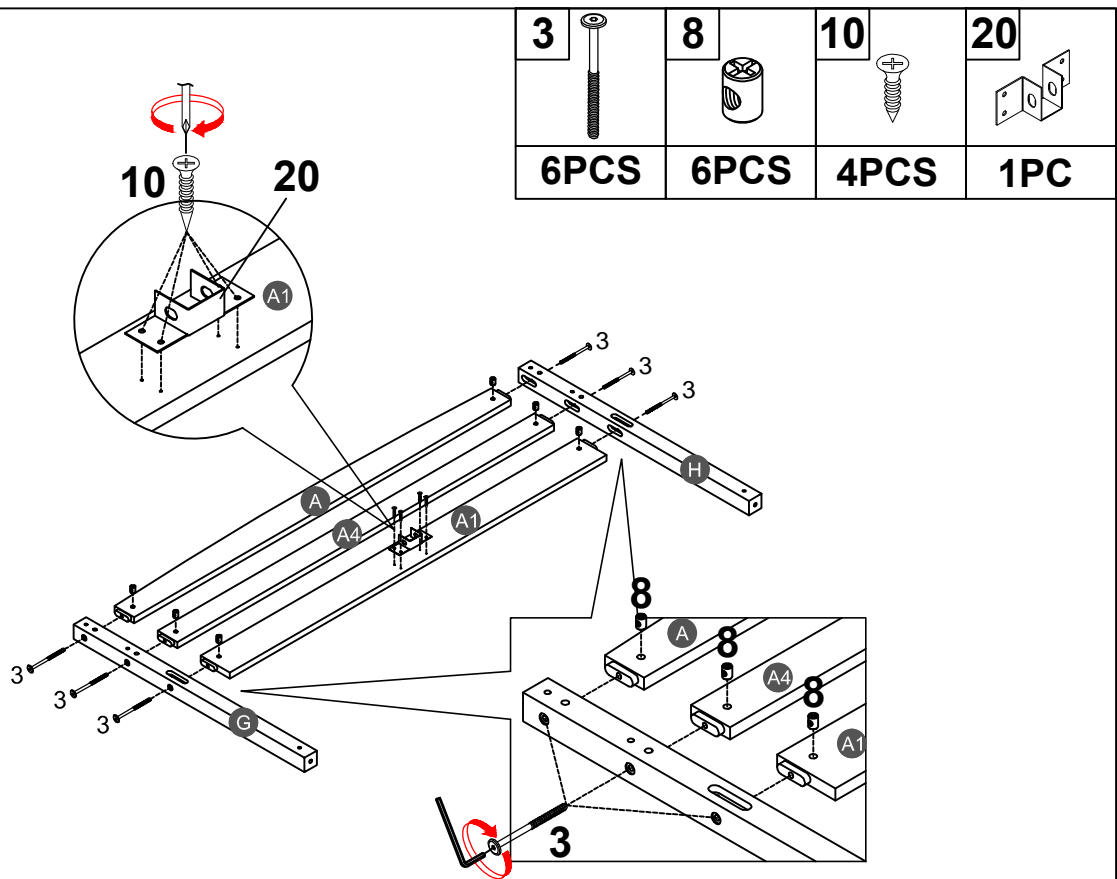

3		8		10		20	
6PCS		6PCS		4PCS		1PC	

# STEP 9:

ÉTAPE

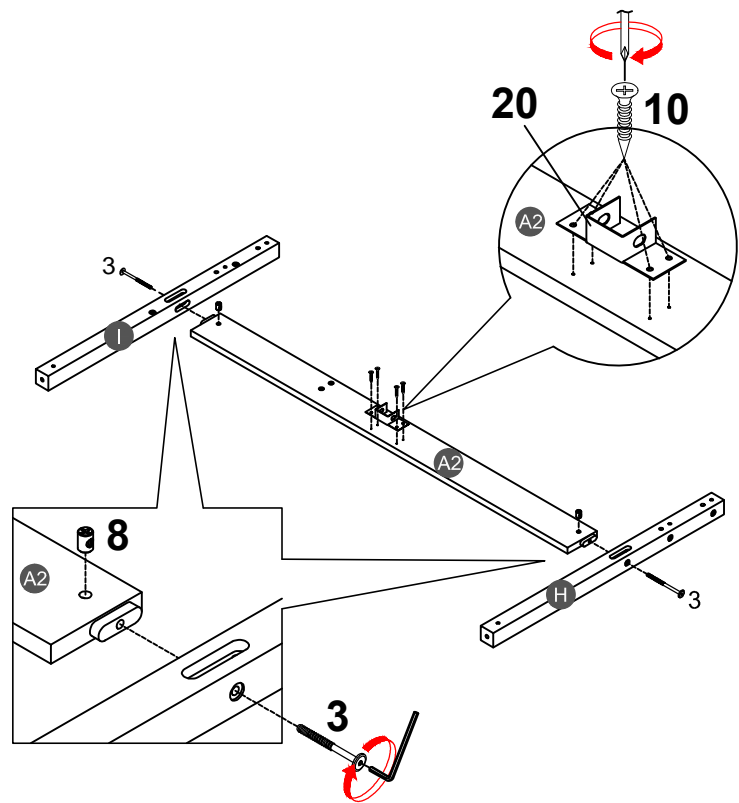



3	
2PCS	
8	
2PCS	
10	
4PCS	
20	
1PC	

# STEP 10:

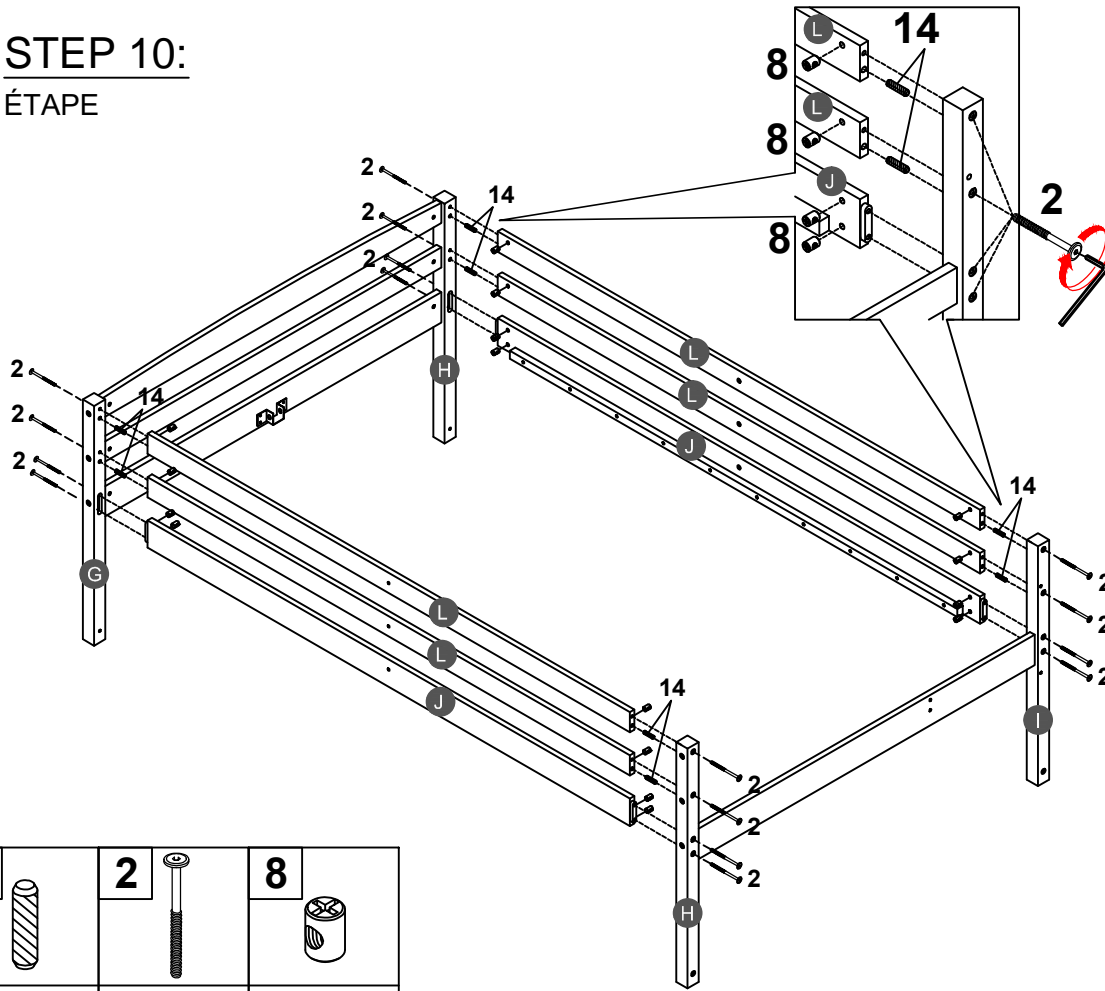
ÉTAPE



14	2	8
		
8PCS	16PCS	16PCS

# STEP 11:

ÉTAPE

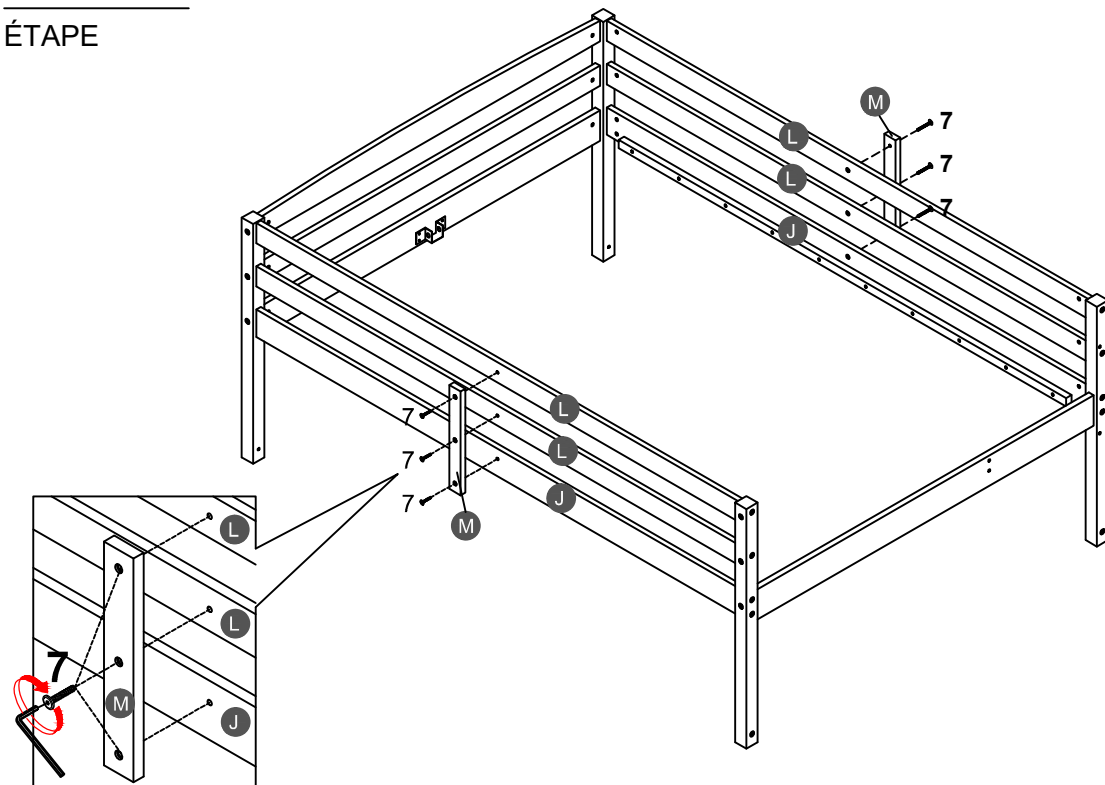

7

6PCS

# STEP 12:

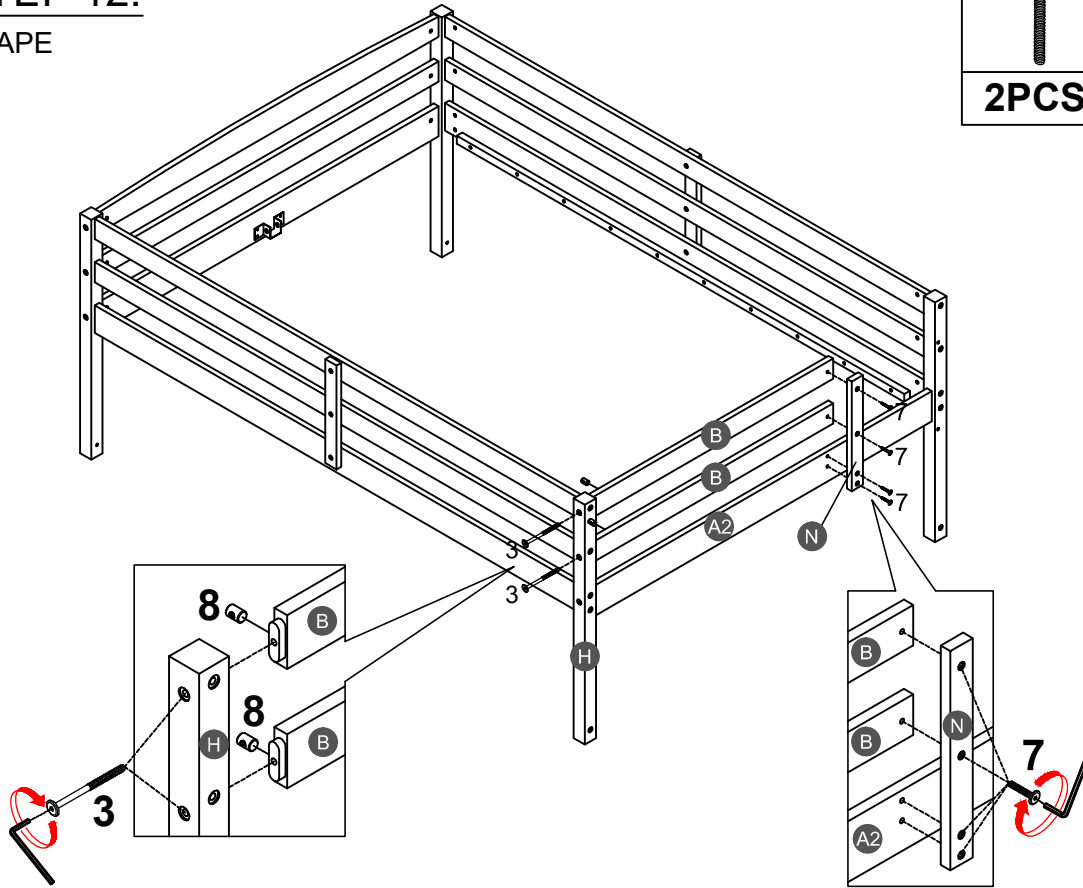
ÉTAPE



3	7
2PCS	4PCS
	8
	2PCS

# STEP 13:

ÉTAPE

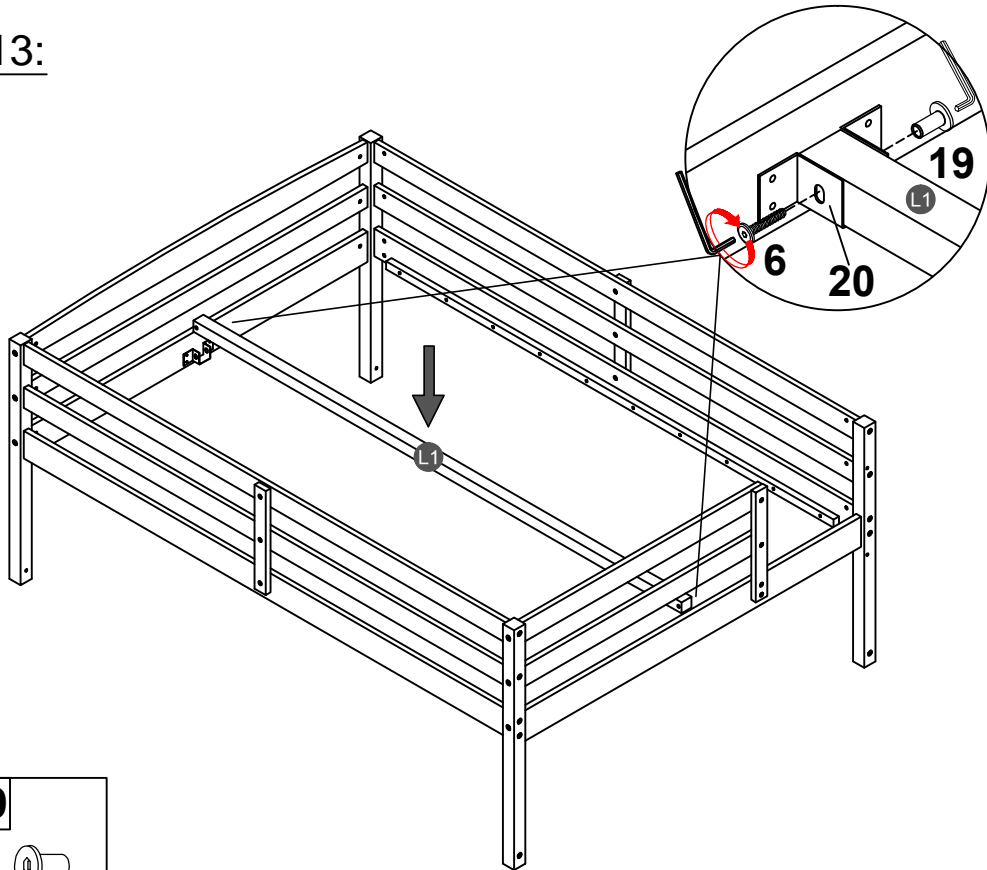

6	19
2PCS	2PCS

# STEP 14:

ÉTAPE

12



32PCS

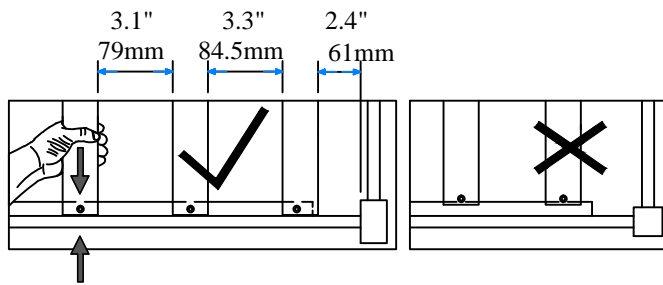
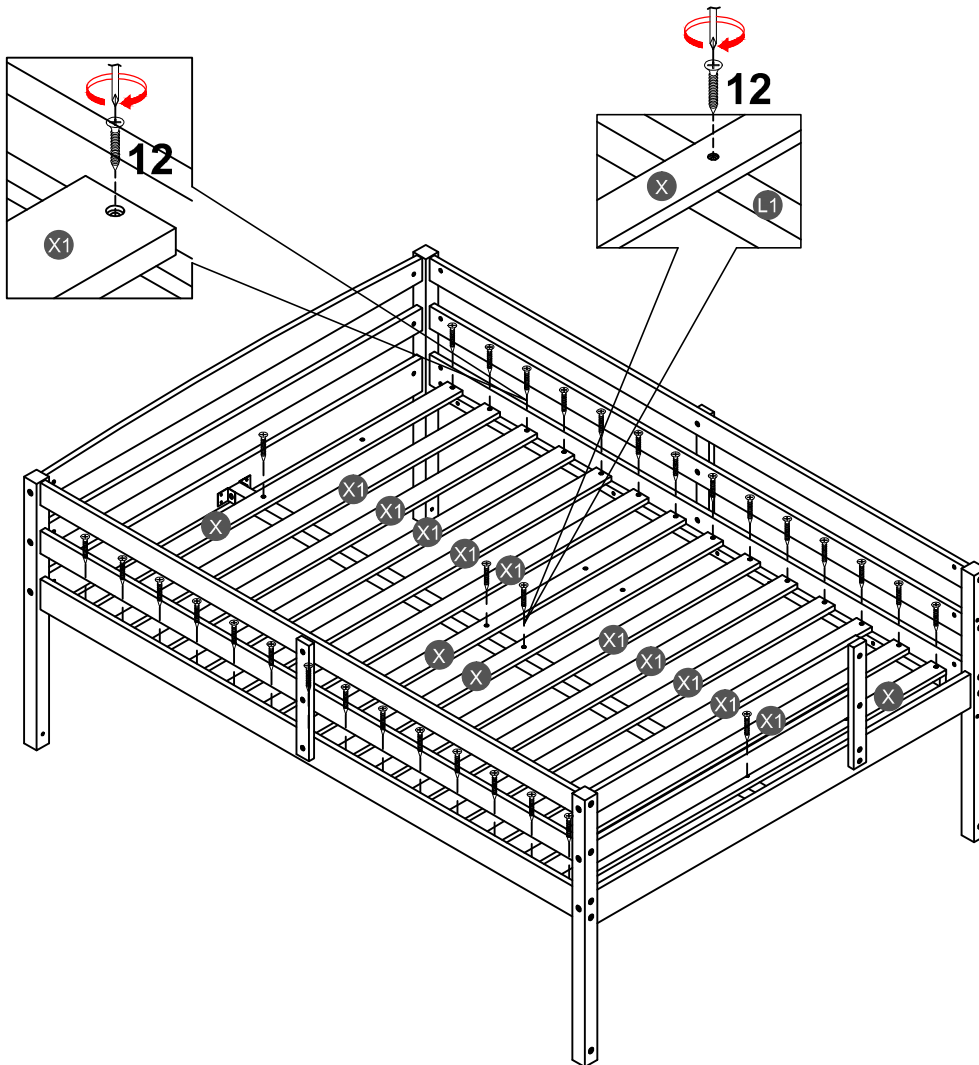

**NOTE:** Please make sure the bed slats close to the side rail before locking the screws to avoid breakage. This step is required for both the left and right sides. Moreover, please do not lock the screws of the bed slats at the outermost edge to avoid damaging.

**Remarque:** Assurez-vous Les lattes du lit fermer du rail latéral avant de verrouiller les vis pour éviter la casse. Cette étape est requise pour tous les deux côtés gauche et droit. De plus, ne verrouillez pas les vis des lattes de lit sur le bord le plus extérieur pour éviter d'endommager.

# STEP 15:

ÉTAPE

6



4PCS

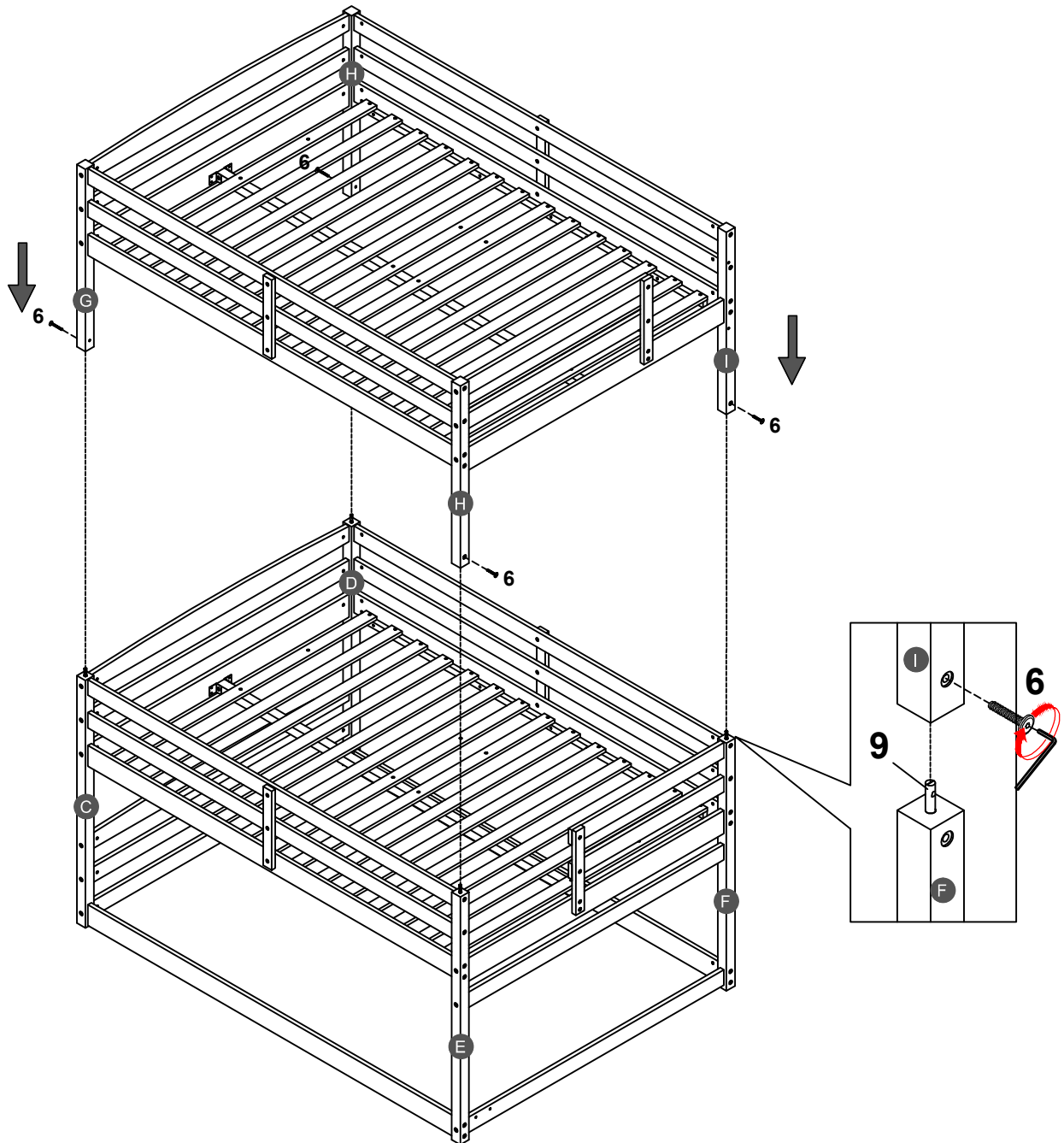

# STEP 16:

ÉTAPE

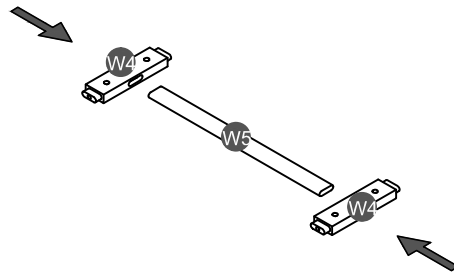

# STEP 17:

ÉTAPE

4		5		8	
4PCS		2PCS		4PCS	

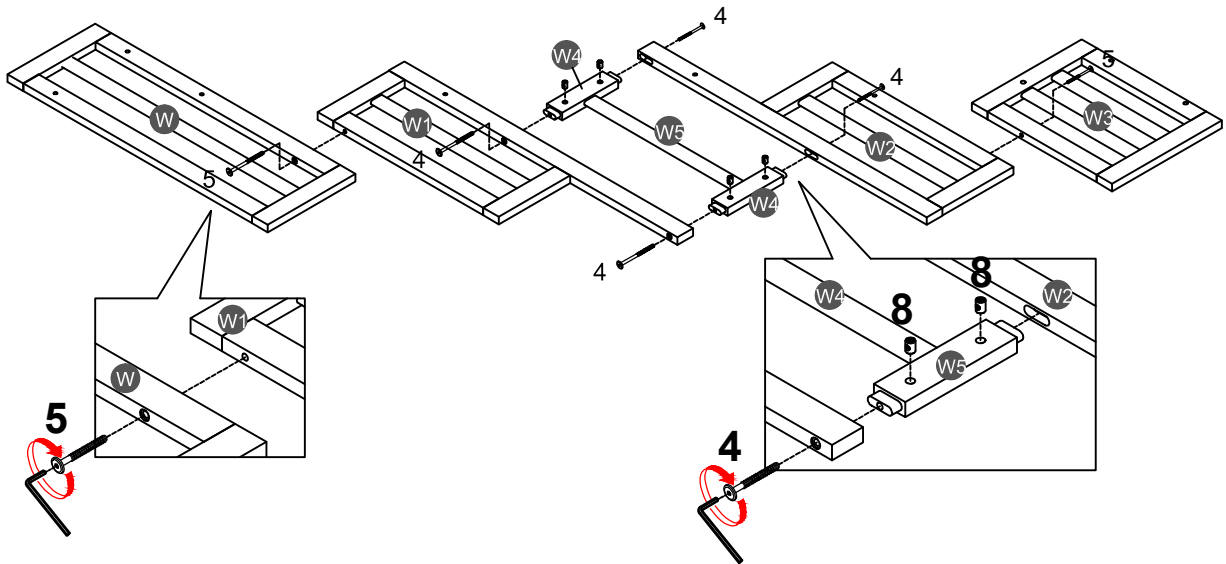

# STEP 18:

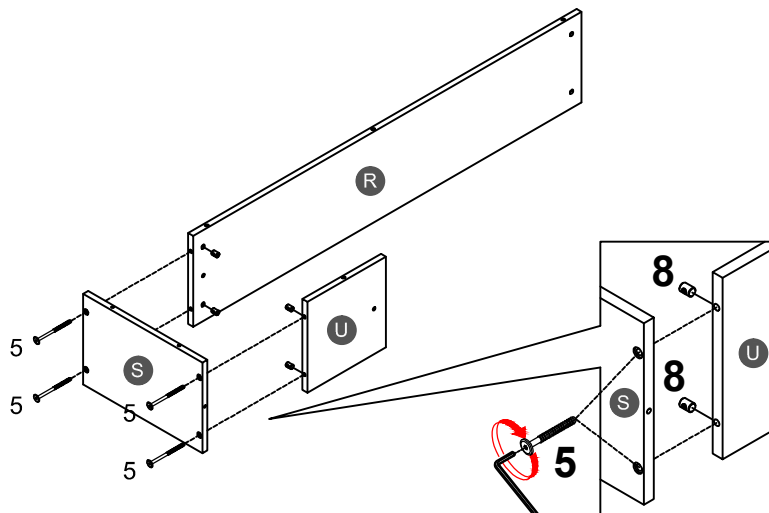

ÉTAPE

5		8	
4PCS		4PCS	



### STEP 19:

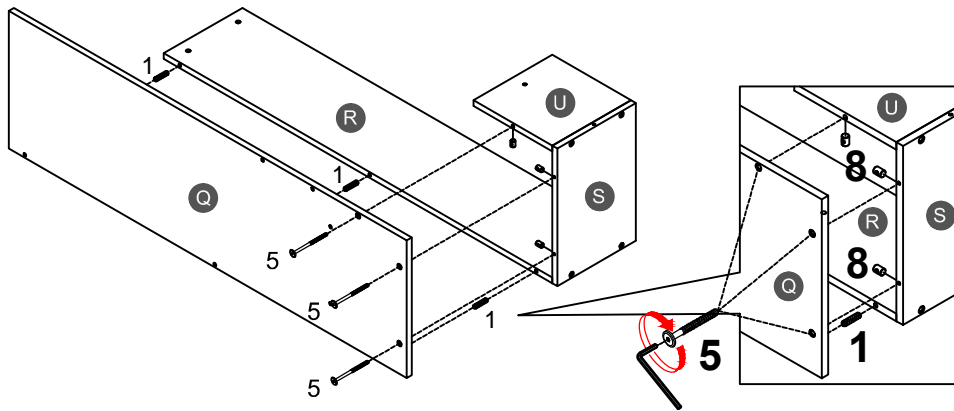

ÉTAPE

1	5	8
		
<b>3PCS</b>	<b>3PCS</b>	<b>3PCS</b>



### STEP 20:

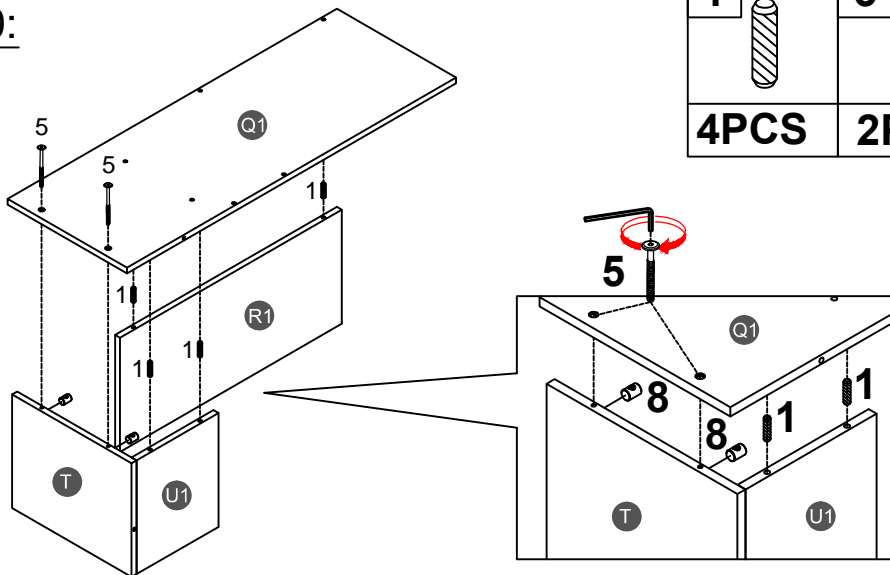

ÉTAPE

1	5	8
		
<b>4PCS</b>	<b>2PCS</b>	<b>2PCS</b>



### STEP 21:

ÉTAPE

1	5	8
		
<b>4PCS</b>	<b>2PCS</b>	<b>2PCS</b>

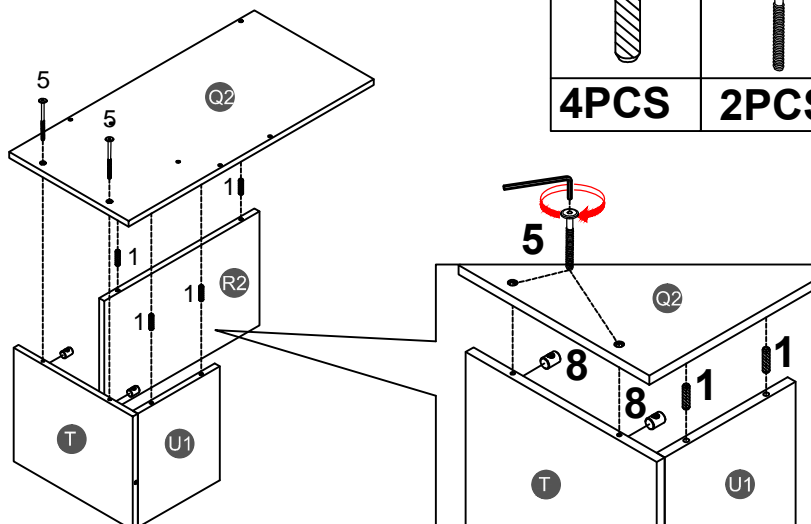

### STEP 22:

ÉTAPE

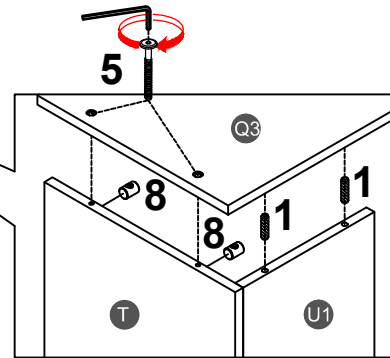
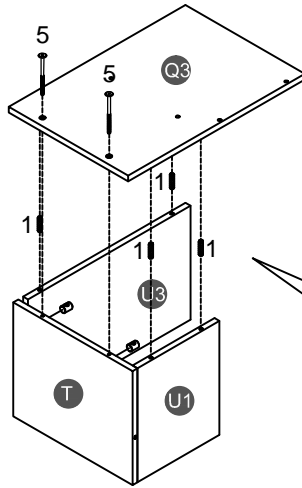

1	5	8
<b>4PCS</b>	<b>2PCS</b>	<b>2PCS</b>

### STEP 23:

ÉTAPE

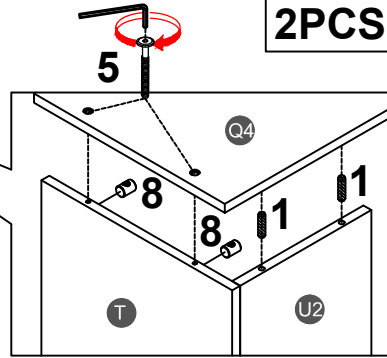
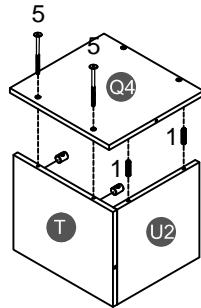

1	5	8
<b>2PCS</b>	<b>2PCS</b>	<b>2PCS</b>

### STEP 24:

ÉTAPE

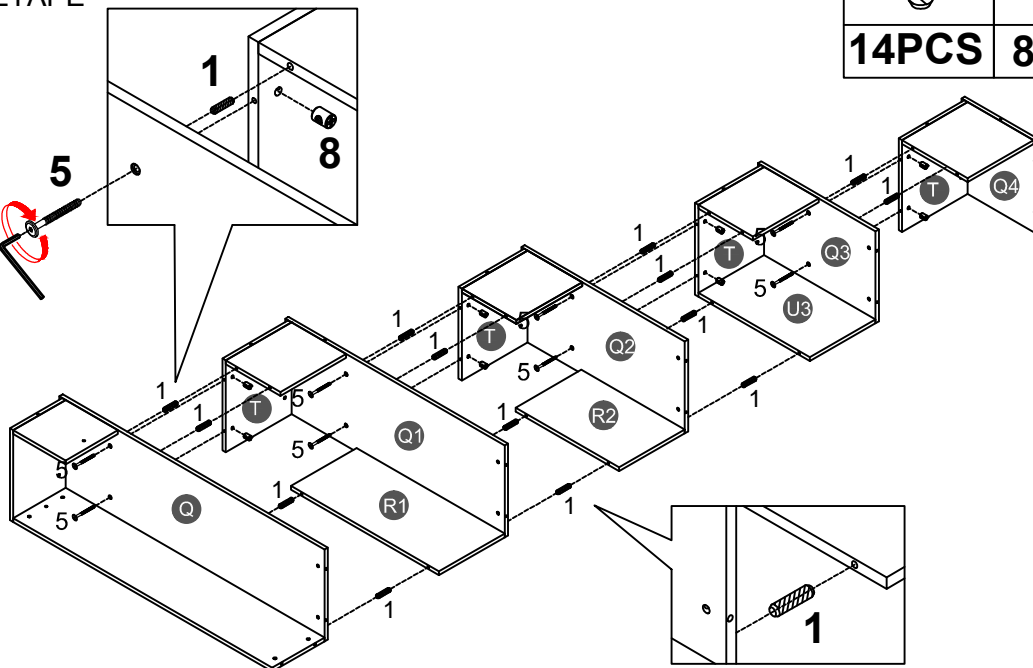

1	5	8
<b>14PCS</b>	<b>8PCS</b>	<b>8PCS</b>

# STEP 25:

ÉTAPE

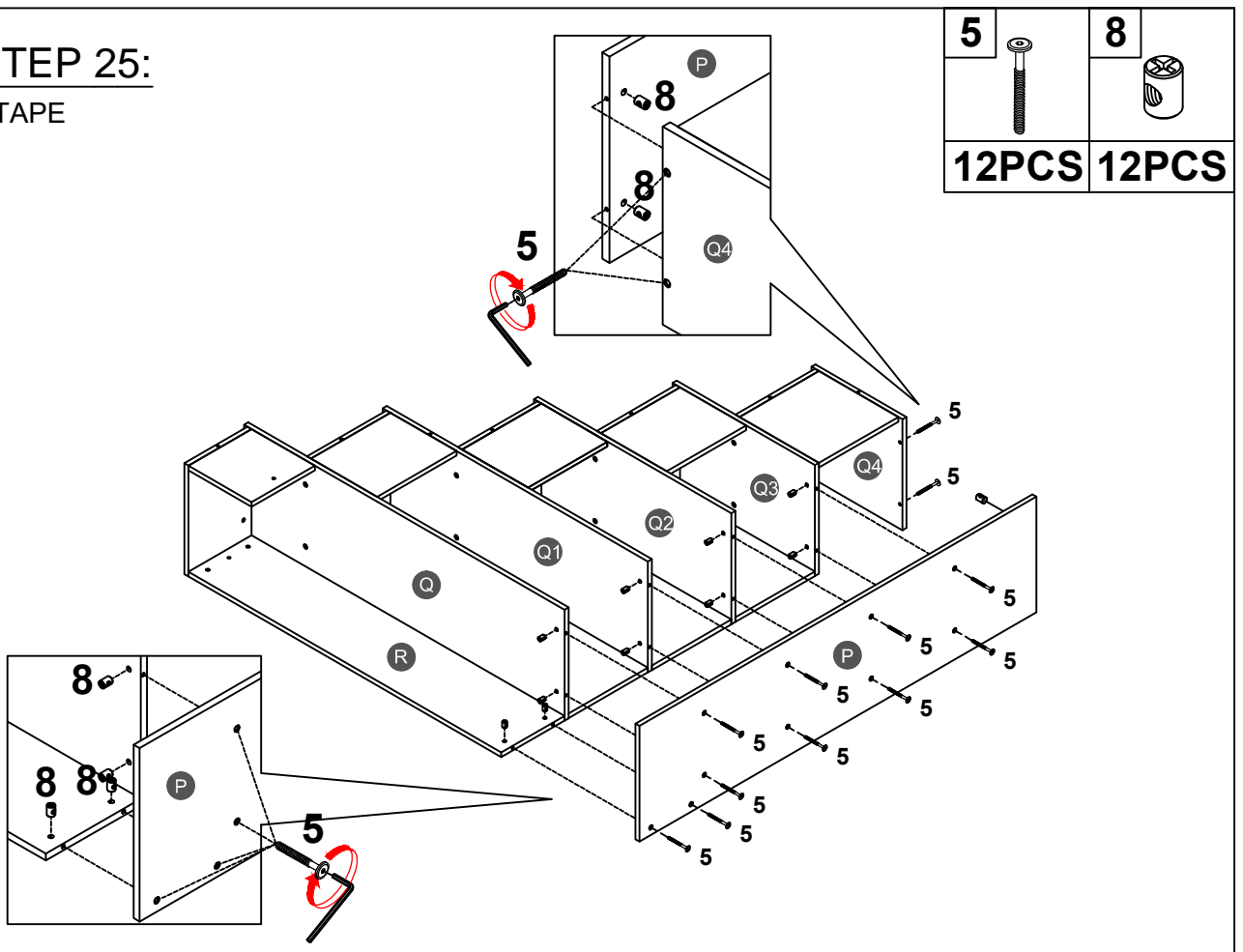

# STEP 26:

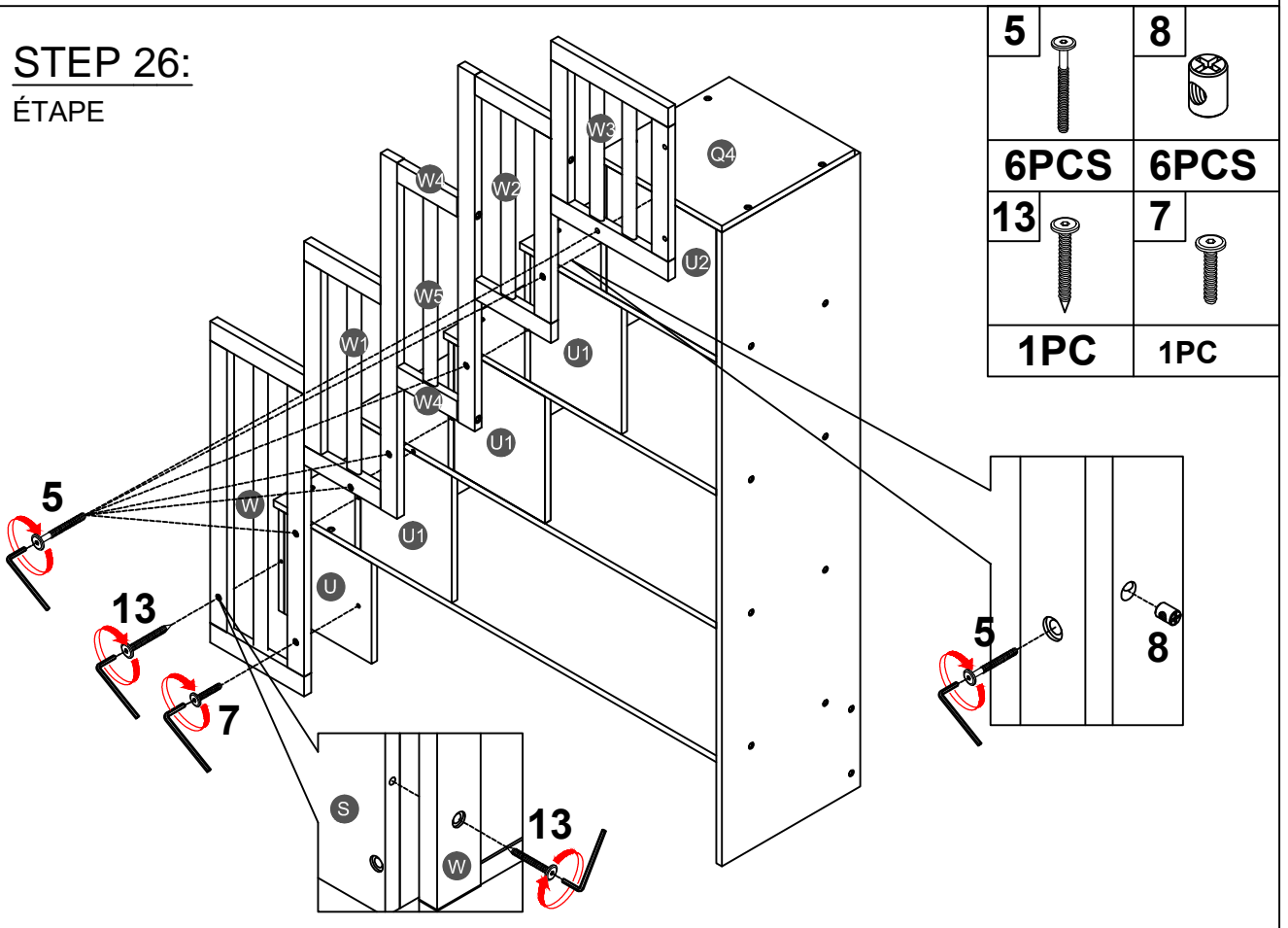

ÉTAPE

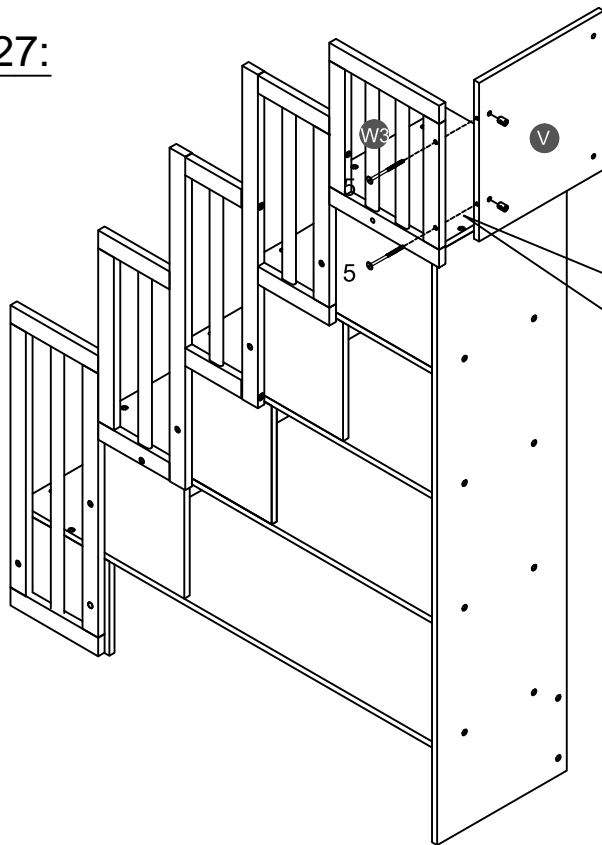

# STEP 27:

ÉTAPE



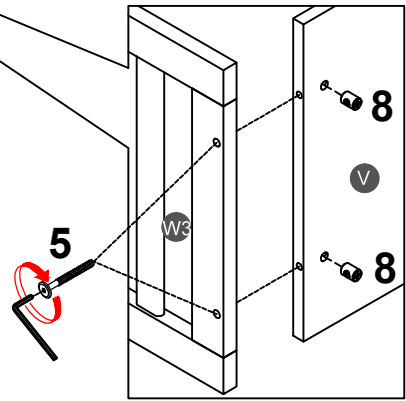

5		8	
2PCS		2PCS	

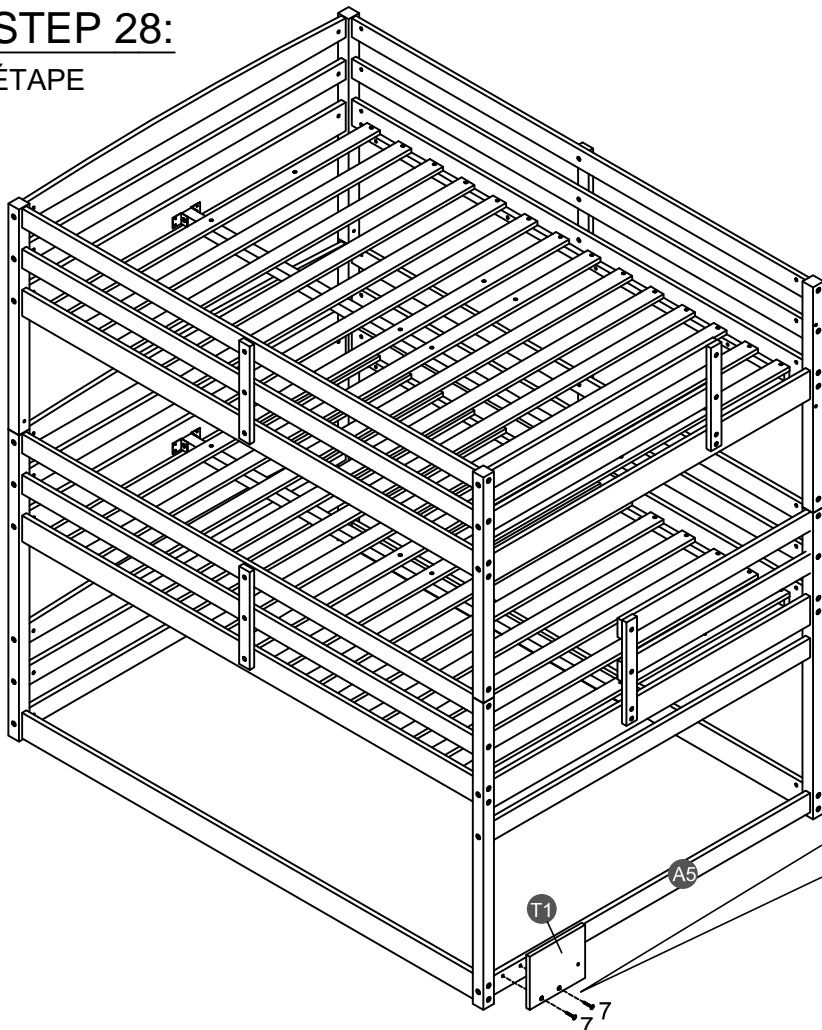

# STEP 28:

ÉTAPE



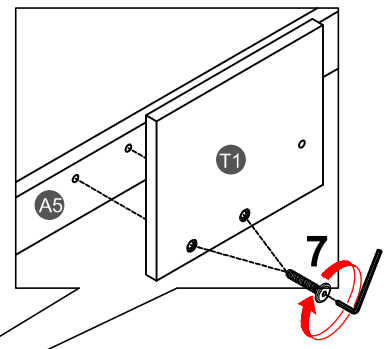

7	
2PCS	

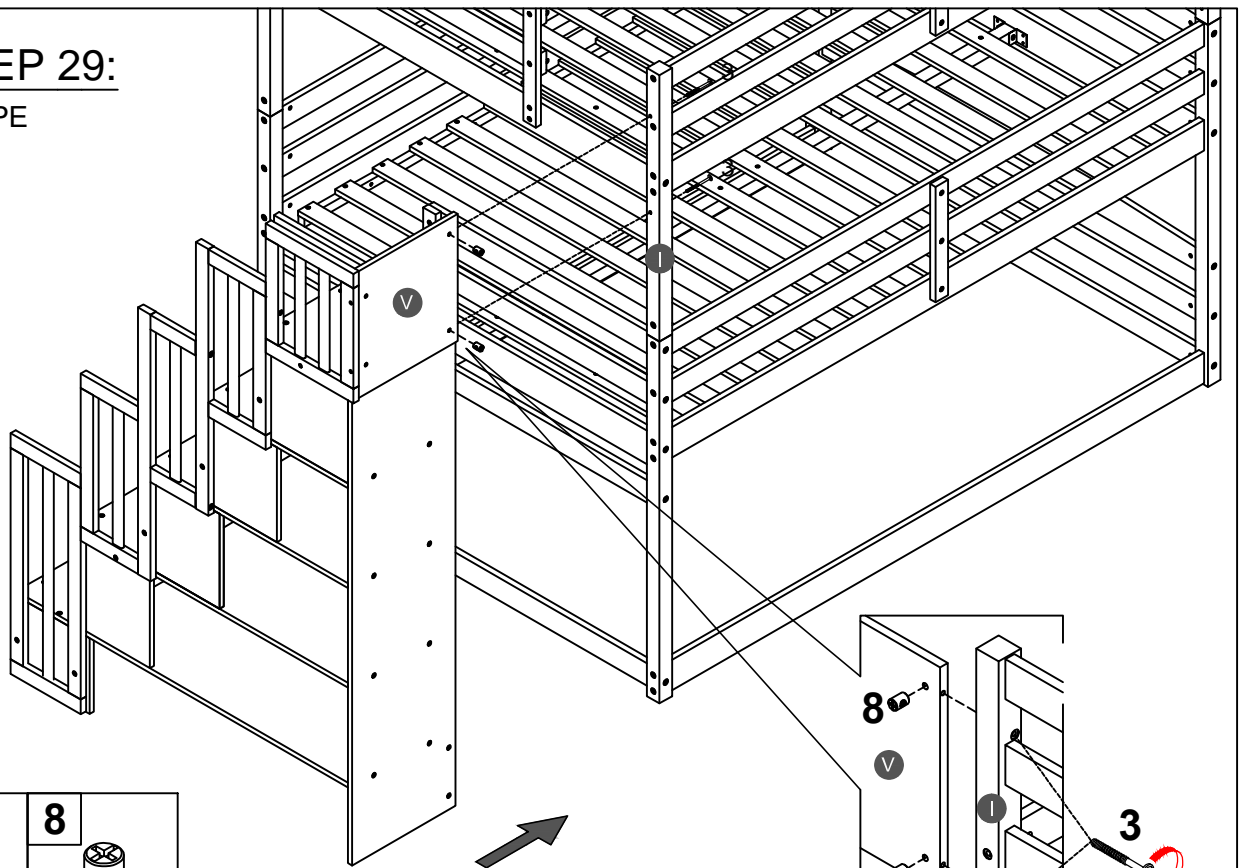

# STEP 29:

ÉTAPE





3	8
	
2PCS	2PCS

# STEP 30:

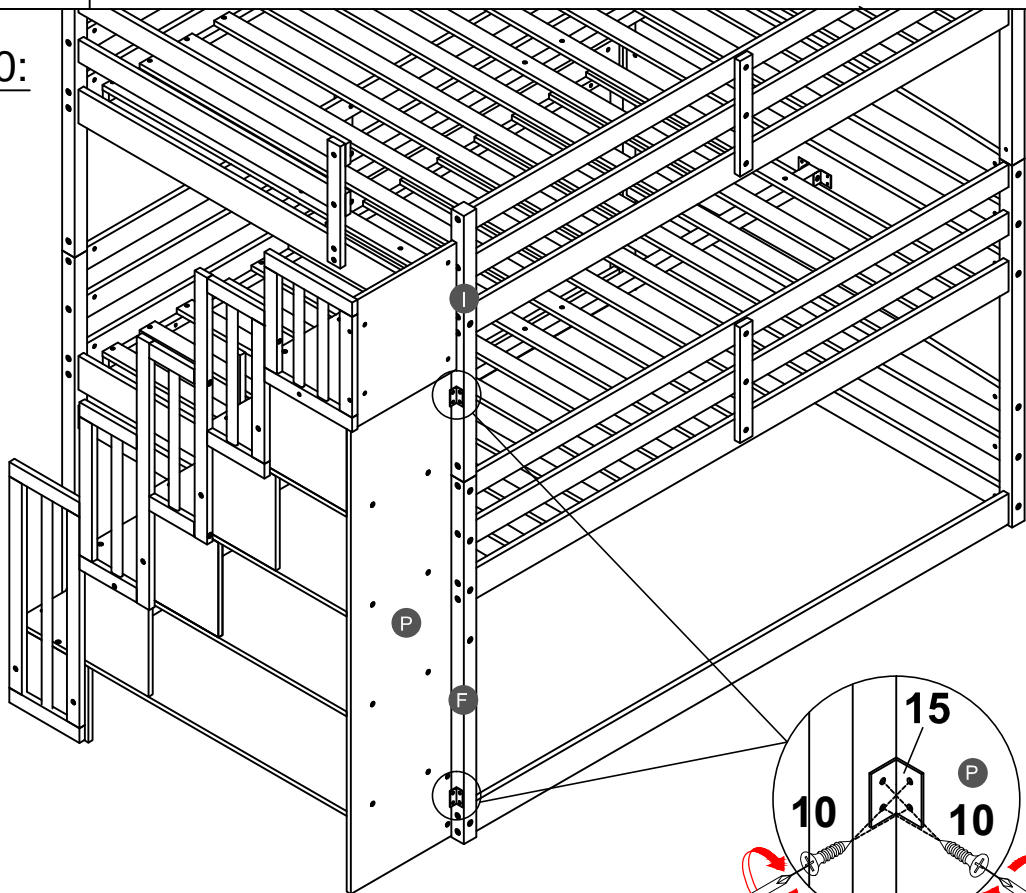
ÉTAPE



10

8PCS
15

2PCS

# STEP 31:

ÉTAPE

7



1PC

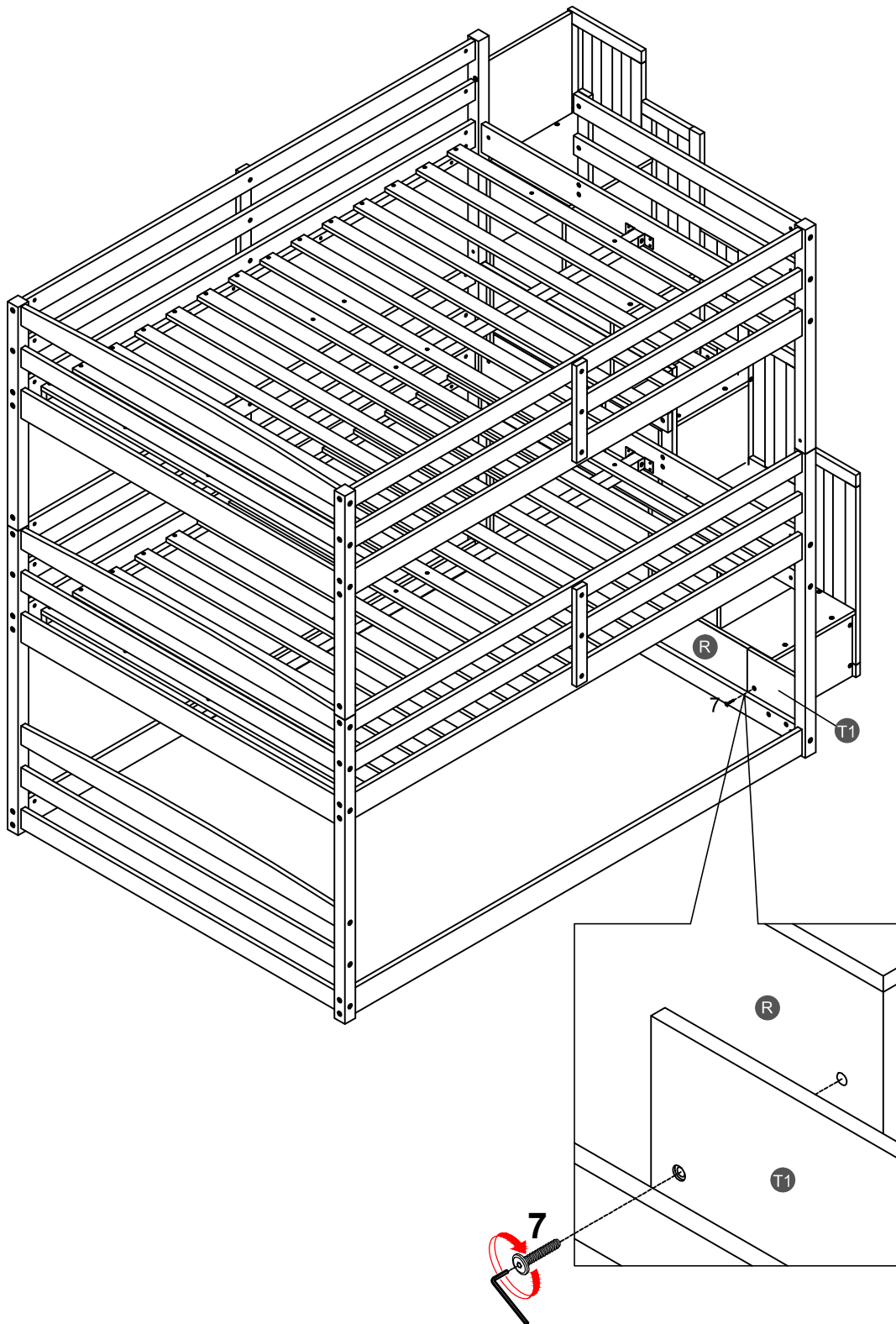



**Make sure to tighten all the screws of the bed.**

Assurez-vous de serrer toutes les vis des de lit.

# STEP A:

ÉTAPE

12	17
	
4PCS	2PCS

Installing the Anti-Tip Bracket.  
Installation du support anti-basculement.

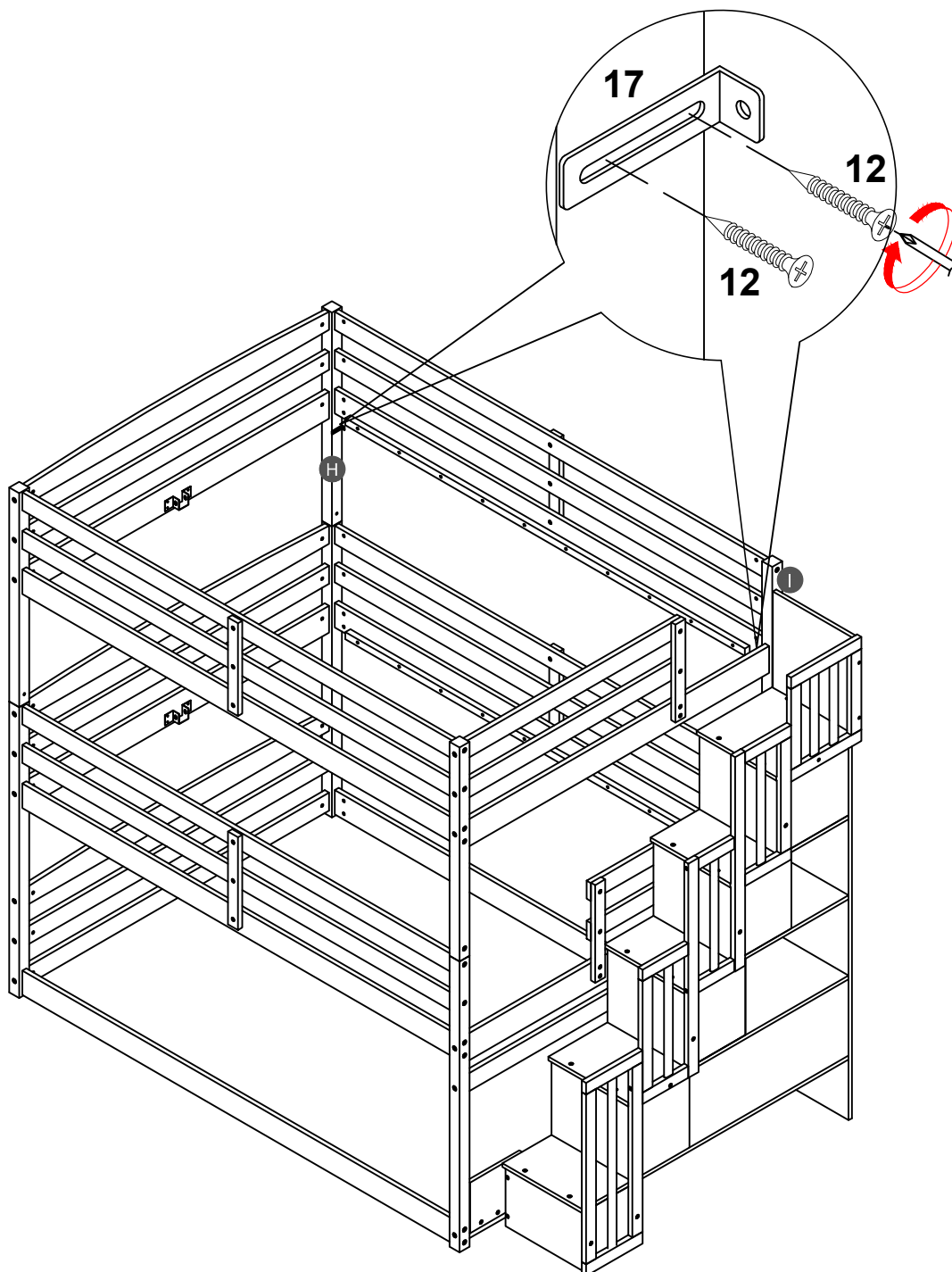

**STEP B:**

ÉTAPE

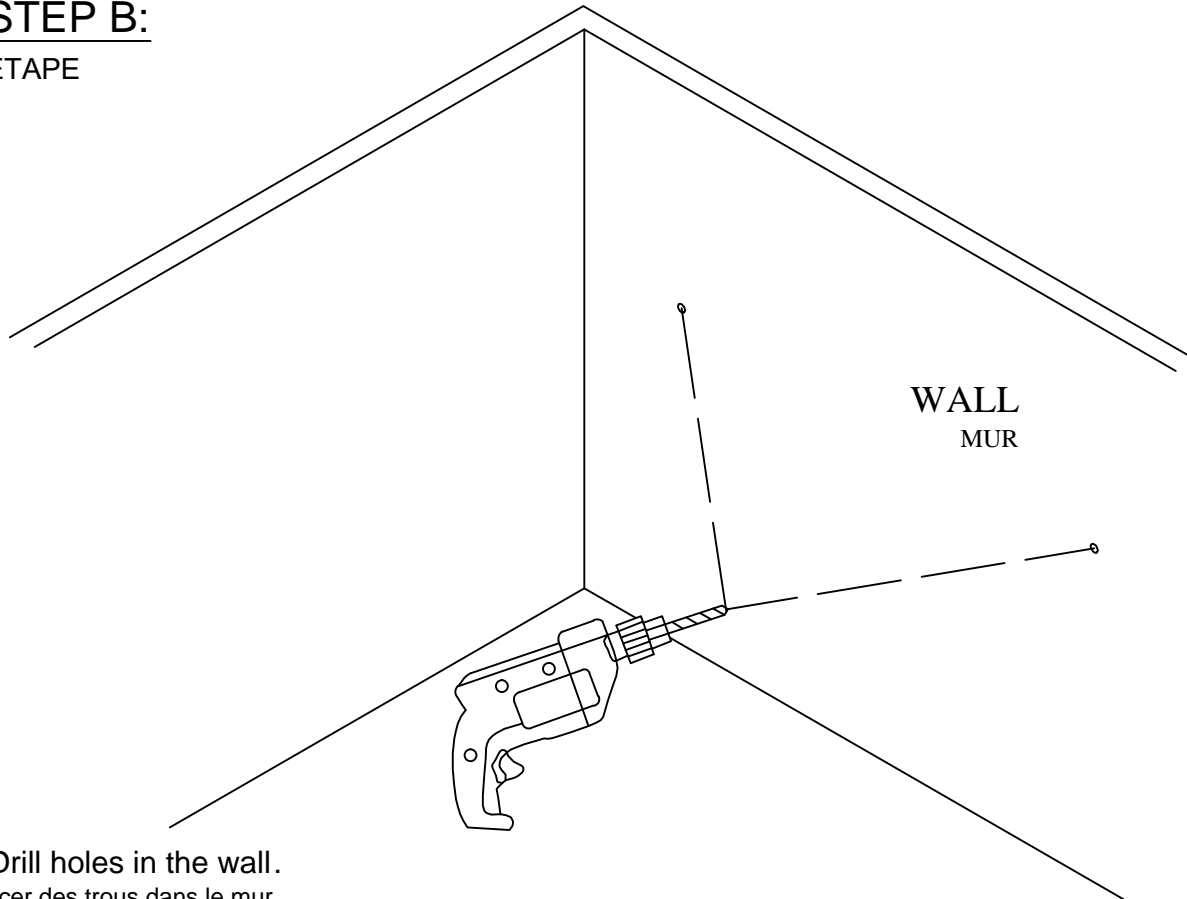

Drill holes in the wall.  
Percer des trous dans le mur.

**STEP C:**

ÉTAPE

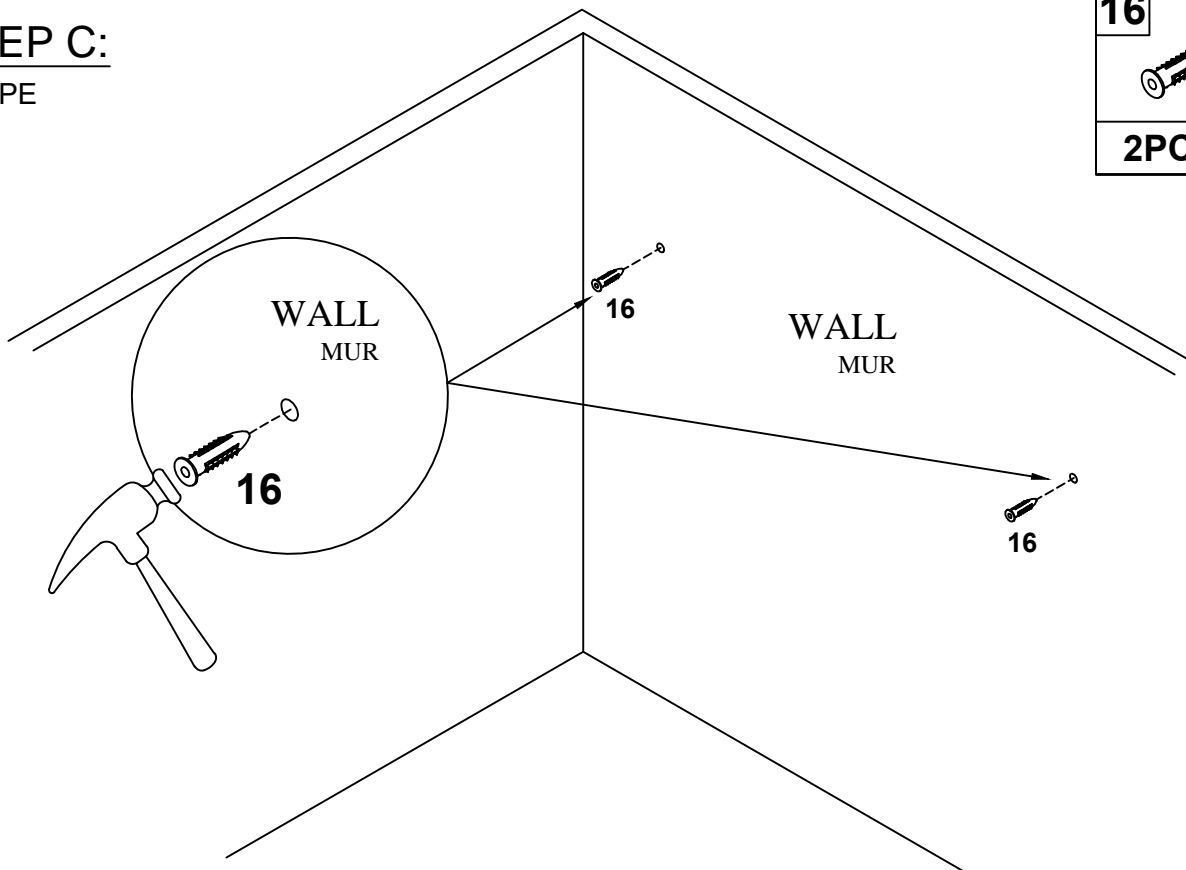

Tap plastic anchor in with a hammer or mallet.  
Enfoncez l'ancrage en plastique avec un marteau ou un maillet.

# STEP D:

ÉTAPE

18



2PCS

Fix the bracket to the wall with screw.  
Fixez le support au mur avec une vis.

