

Assembly Instructions

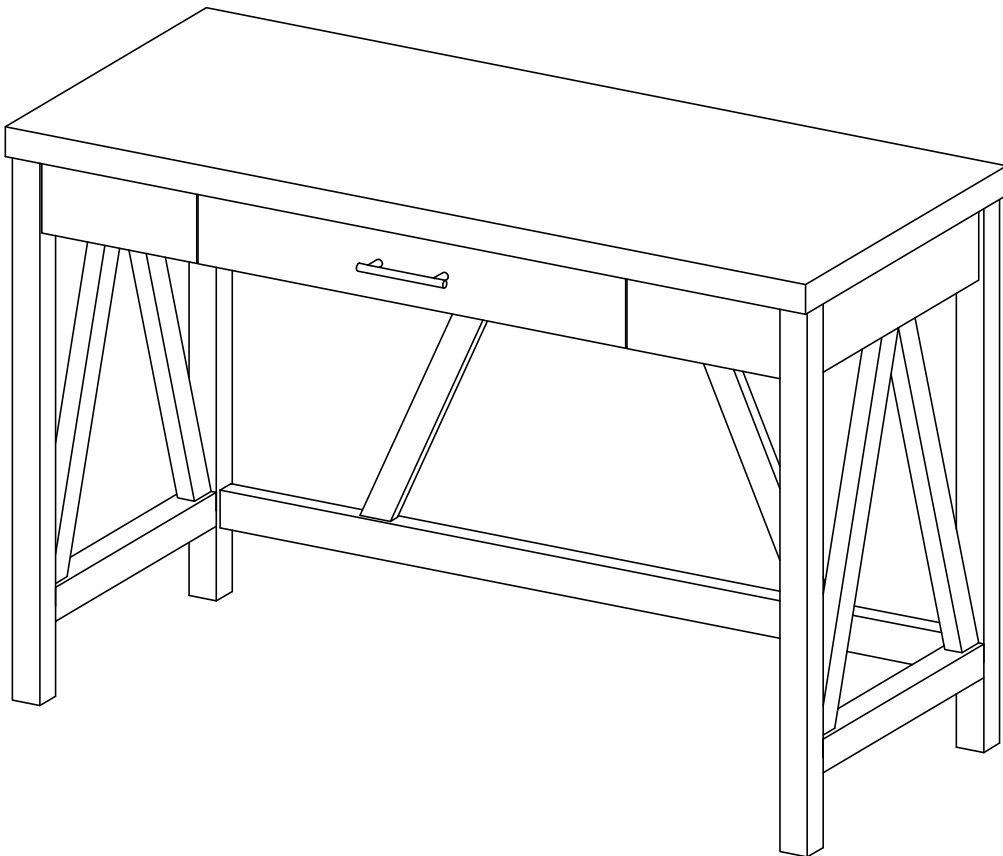

General Assembly Guidelines

- I. Ensure that all parts and hardware are available before beginning assembly.
- II. Follow each step carefully to ensure the proper assembly of this product.
- III. Two people are recommended for ease in the assembly of this product.
- IV. The three main types of hardware used to assemble this product are : wood dowels , screws and bolts.
- V. The provided glue is to secure wood dowels in place . When first inserting dowels , locate the appropriate hole for the dowel , place a small amount of glue in the hole and insert the dowel . Wipe away excess glue immediately.

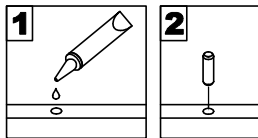

In future assembly steps when dowels are necessary to attach assembly parts together , place a small amount of glue on the end of the dowel before attaching parts together . Wipe away excess glue immediately.

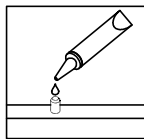

- VI. A Phillips head screwdriver is required for the assembly of this product .

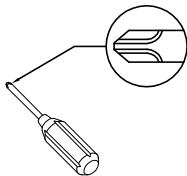



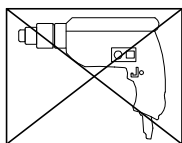



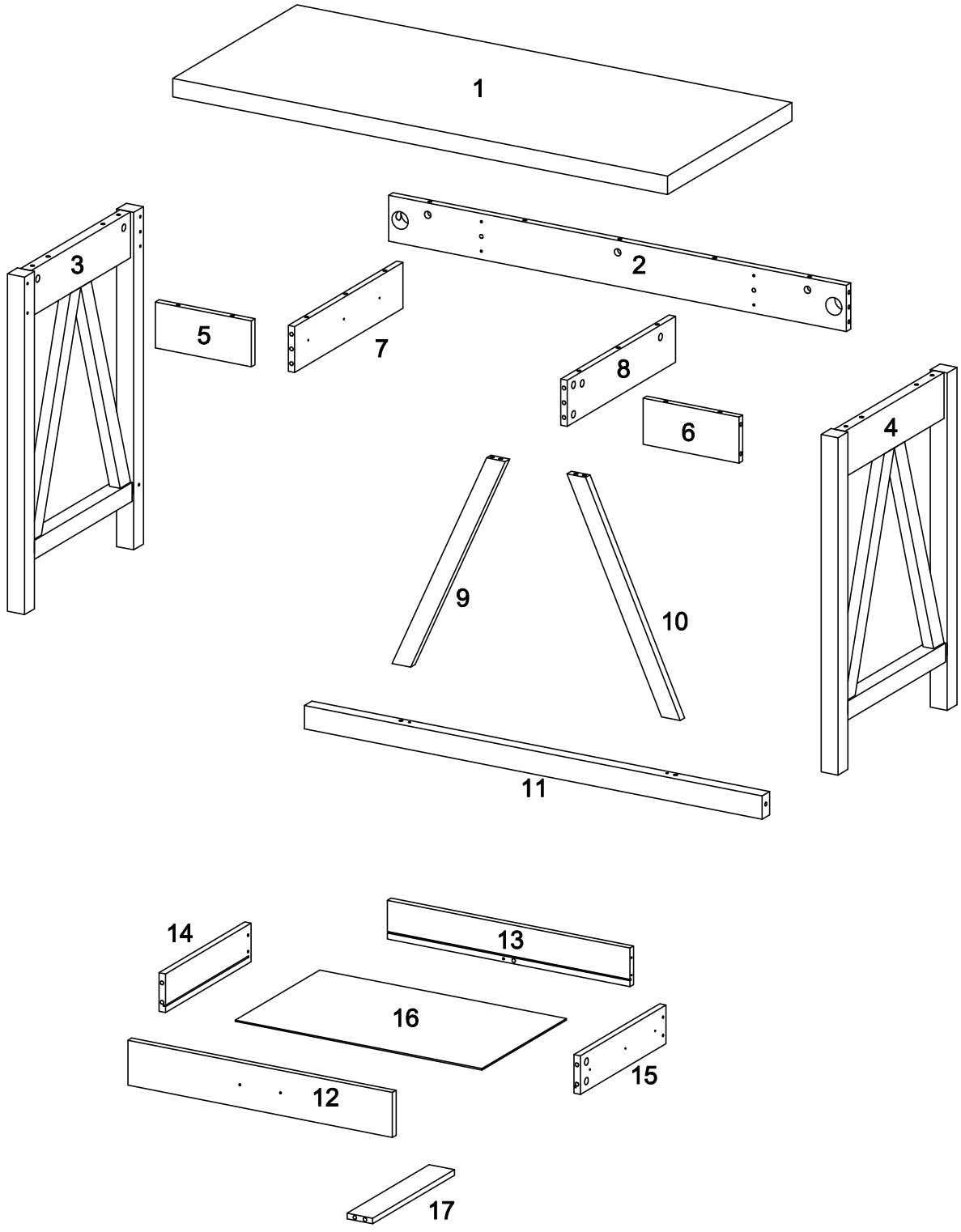



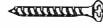
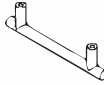

- VII. Power tools should not be used to assemble this product .

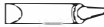

Parts List

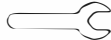
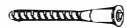

Hardware List

A		Ø8x30mm	Wooden dowel	24 pcs
B		Ø6x35mm	Cam bolt	28 pcs
C		Ø15x11mm	Cam lock	28 pcs
D		Ø4x32mm	Screw	9 pcs
E			Handle	1 pc
F		Ø4x22mm	Bolt	2 pcs
G		Ø30mm	Sticker	28 pcs
H			Glue tube	2 pcs
J		Ø5/16 in	Half moon washer	4 pcs
K		Ø8x60mm	Cam bolt	4 pcs
L		Ø5/16 in	Nut	4 pcs
M		Ø5/16 in	Wrench	1 pc
N		Ø6x50mm	Bolt	2 pcs
P		M 4	Wrench	1 pc
Q		Ø38mm	Plastic cover	4 pcs
R		Ø3x12mm	Screw	12 pcs
S			Drawer slider	1 sets

* Note: This piece comes preassembled for shipping purposes and must be disassembled to complete the desk assembly.

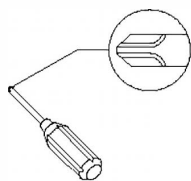

**Philips head screwdriver required for assembly
(not included)**

*The hardware quantities listed above are required for proper assembly.
Some extra hardware may also have been included.*

Step 1

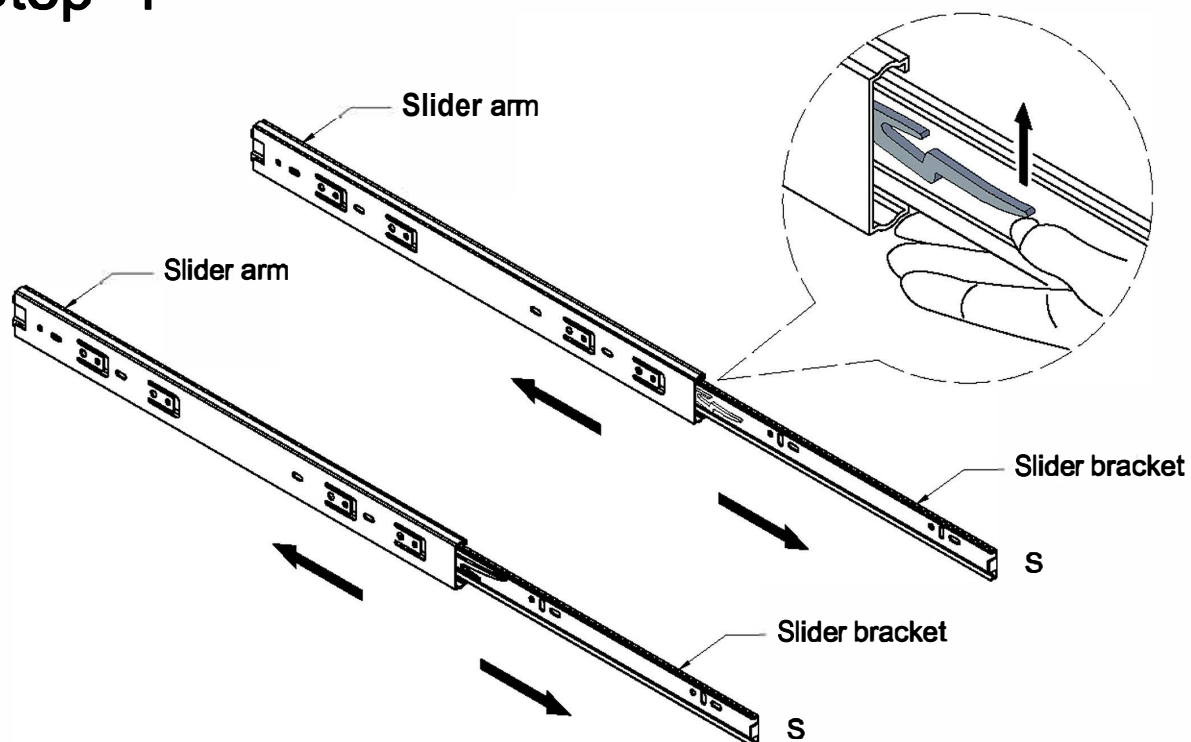

Disassemble drawer slider (S) by sliding the slider arm and slider bracket apart. Depress the small lever of the slider bracket and carefully pull the two pieces apart. Repeat this process for both drawer sliders (S).

Step 2

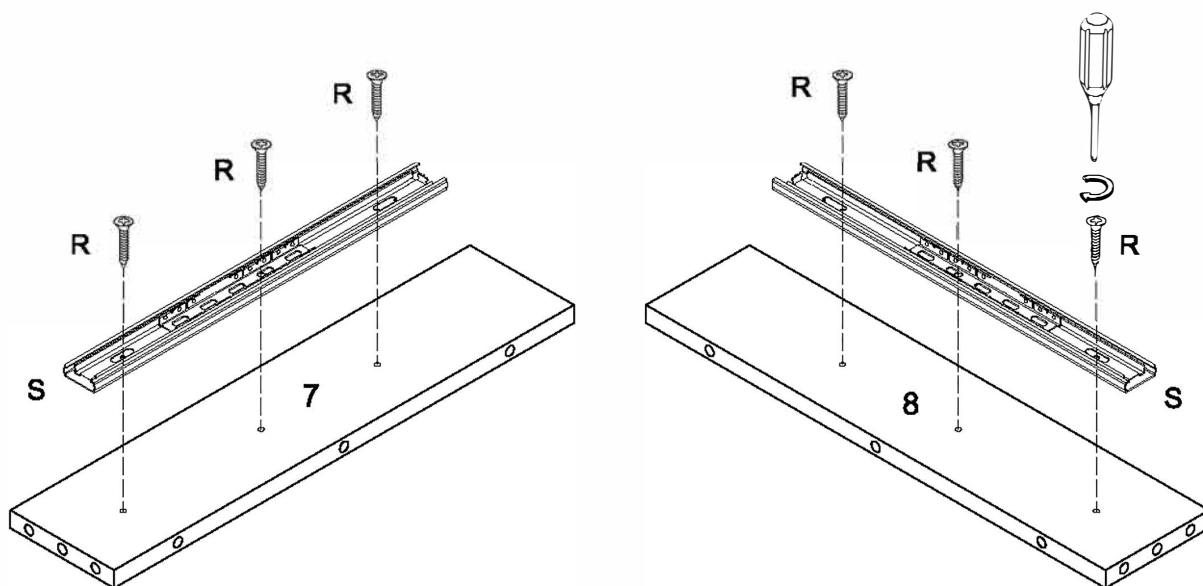

Secure drawer slider arms (S) to side panels (7,8) with screw (R).

Step 3

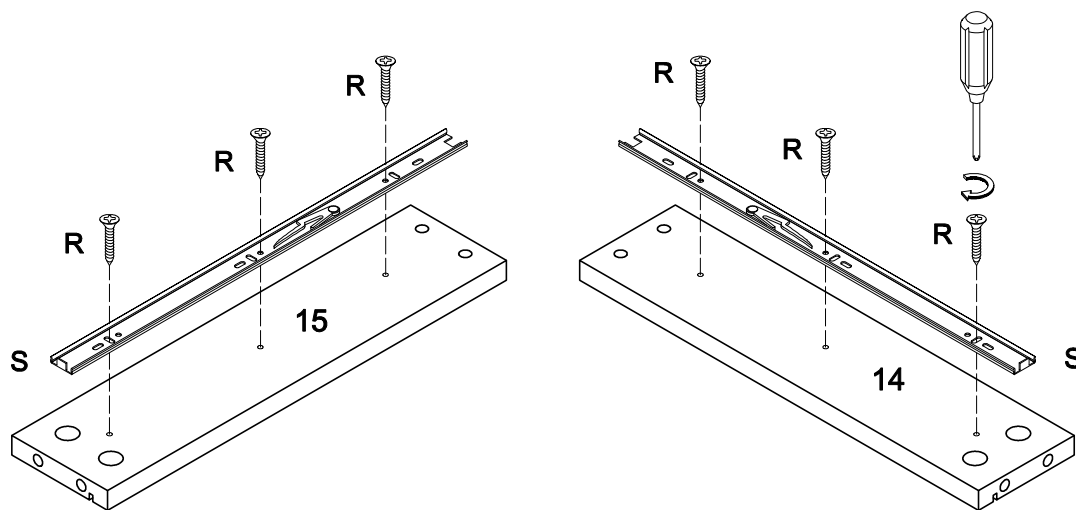

Secure slider brackets (S) to drawer side panel (14,15) with screw (R).

Step 4

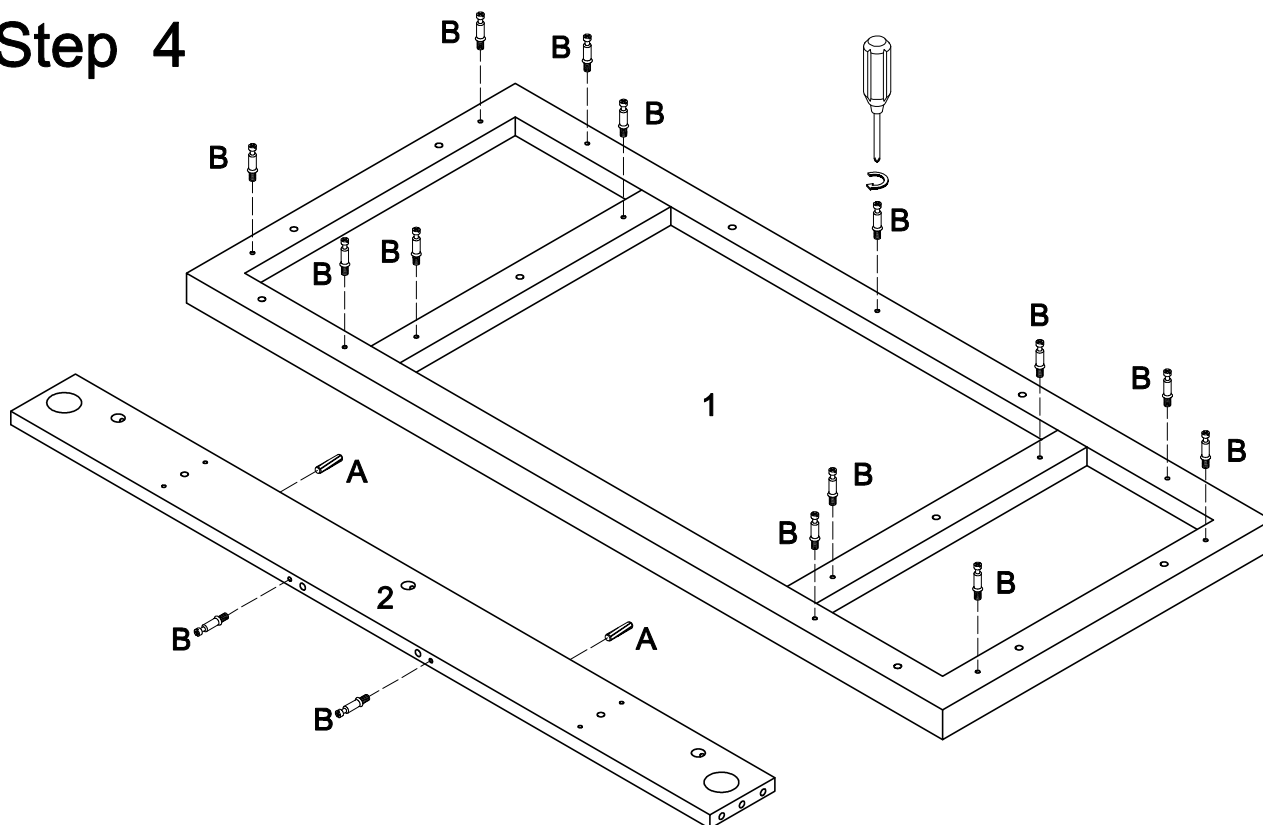

Secure cam bolt (B) to top panel (1). Insert wooden dowel (A) and secure cam bolt (B) to back panel (2).

Step 5

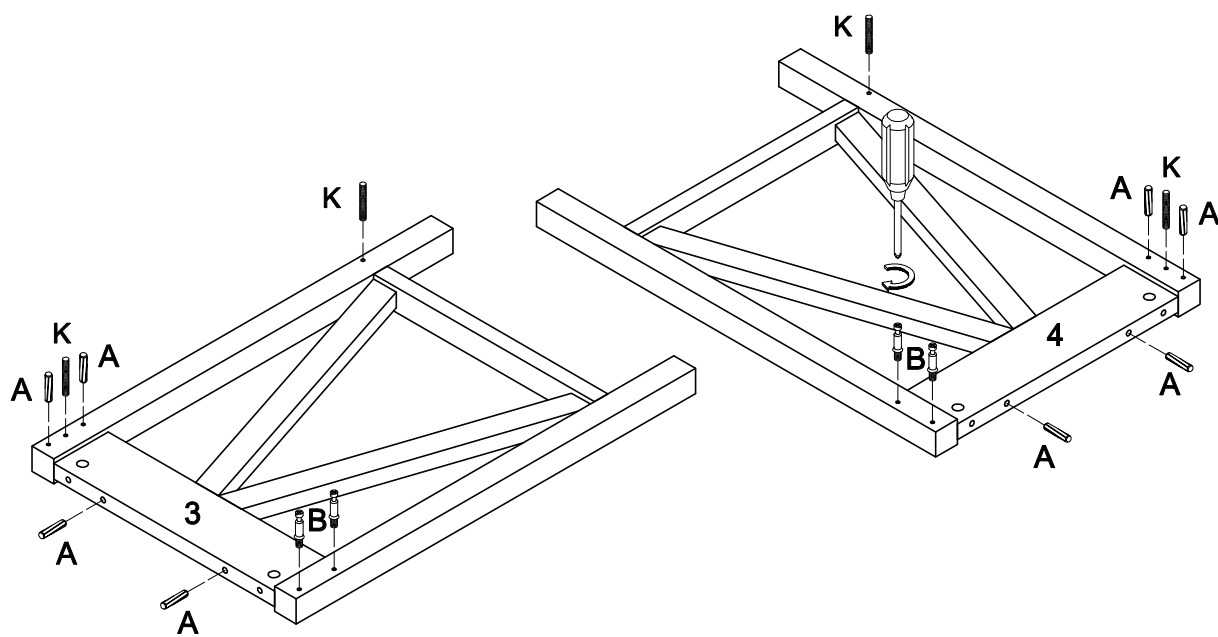

Insert wooden dowel (A) and secure cam bolt (B,K) to side frame (3,4).

Step 6

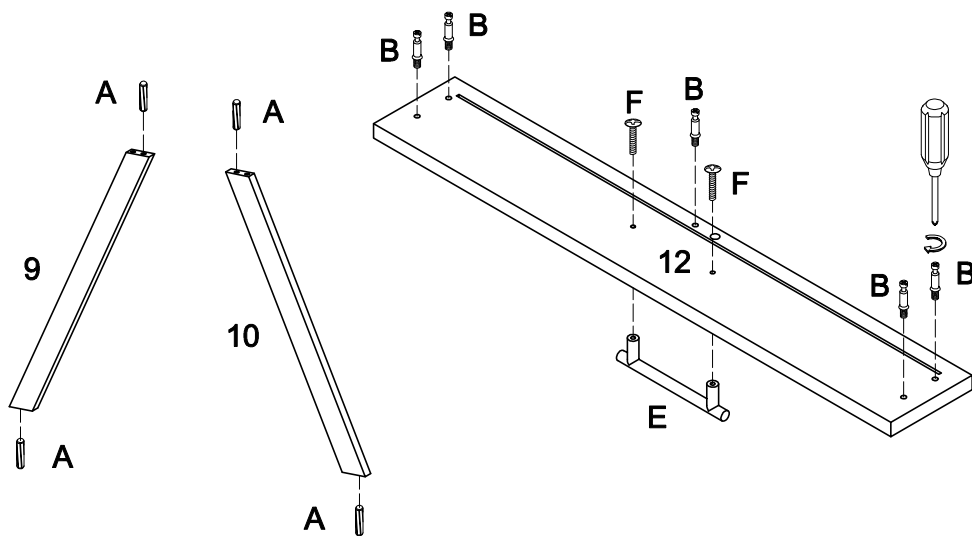

Insert wooden dowel (A) to parts (9,10). Secure cam bolt (B) to drawer front panel (12), then secure handle (E) with bolt (F).

Step 7

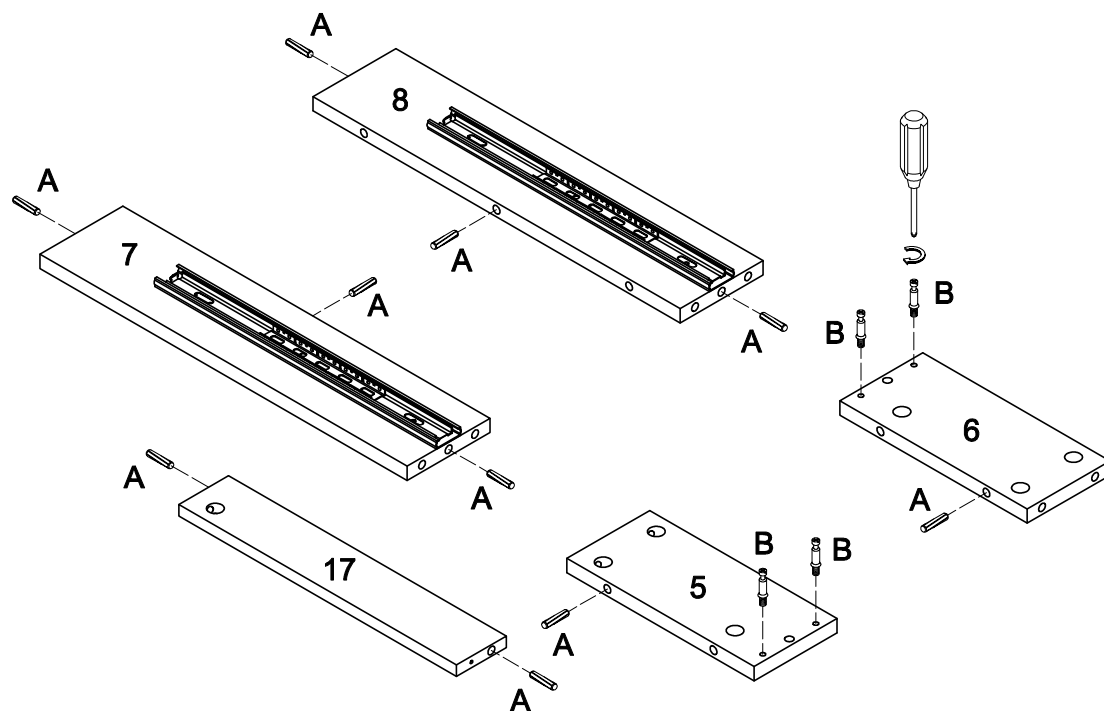

Insert wooden dowel (A) to side panel (7,8) and parts (5,6,17). Secure cam bolt (B) to parts (5,6).

Step 8

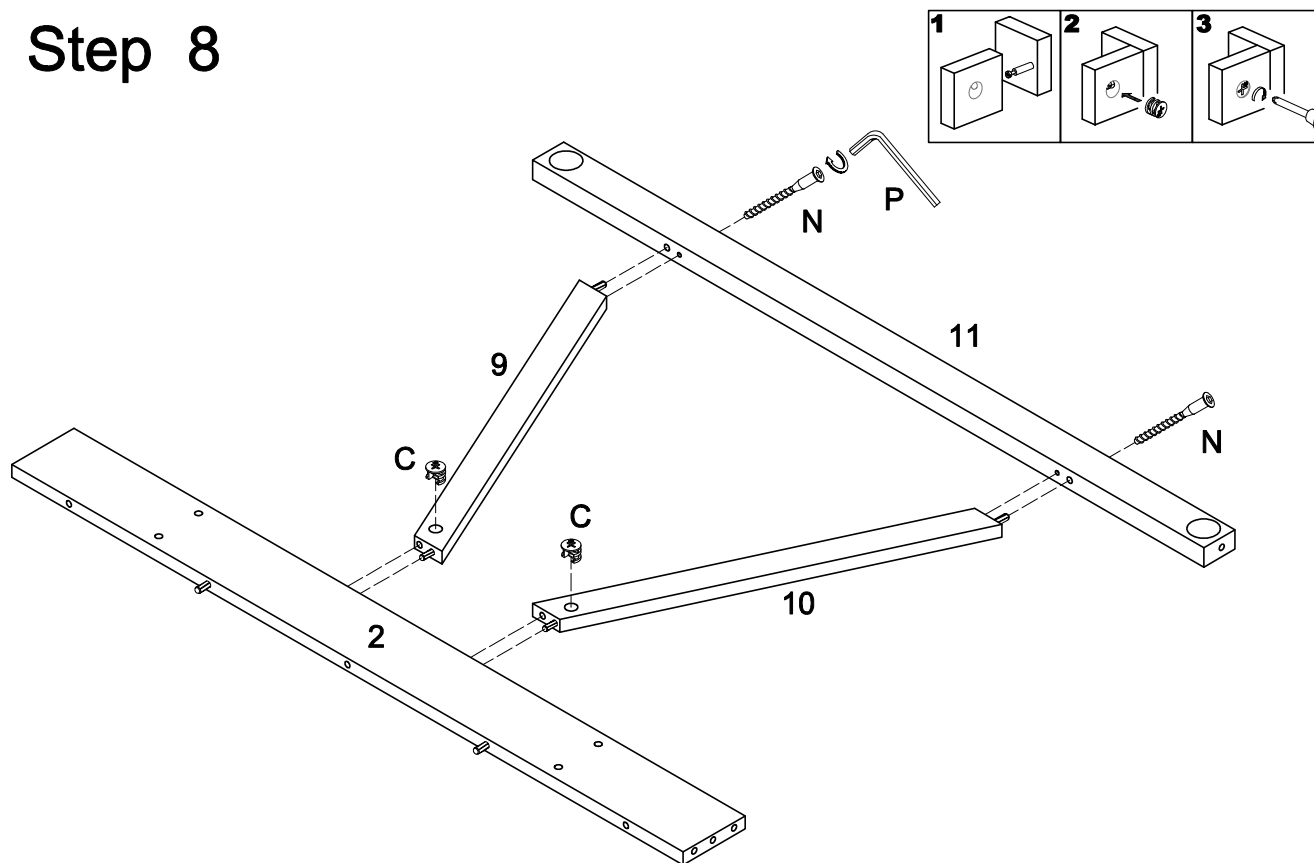

Insert parts (9,10) into back panel (2) and parts (11), then insert and secure cam lock (C) to parts (9,10), and use wrench (P) to secure parts (11) to parts (9,10) with bolt (N) to lock them.

Step 9

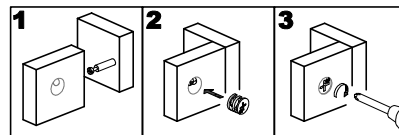
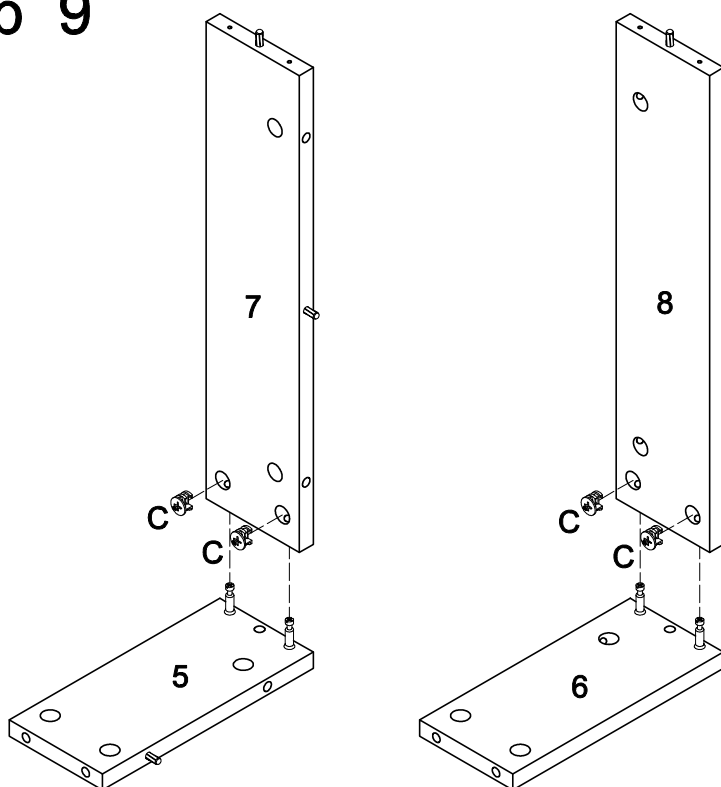

Insert parts (5,6) into side panel (7,8), then insert and secure cam lock (C) to side panel (7,8) to lock it.

Step 10

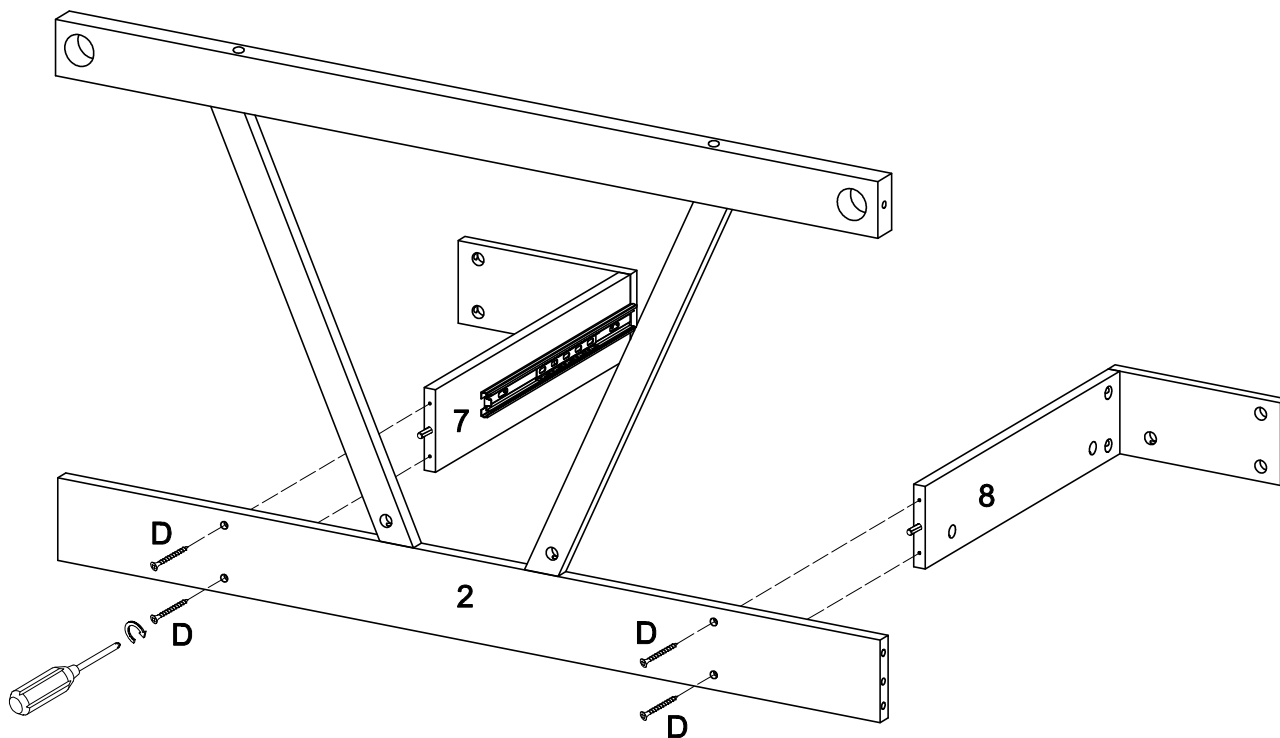

Insert side panel (7,8) into back panel (2), then secure it with screw (D).

Step 11

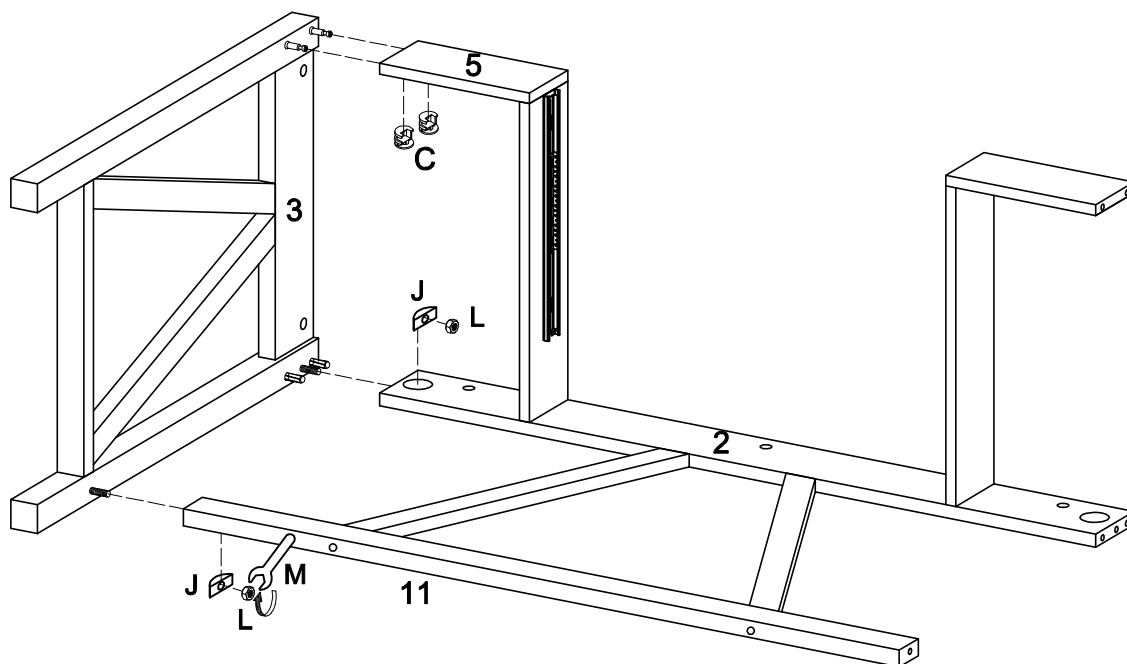
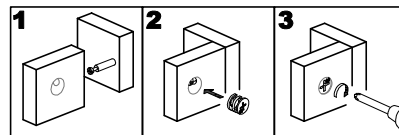

Insert side frame (3) into back panel (2) and parts (5,11), then insert and secure cam lock (C) to parts (5), and use wrench (M) to secure back panel (2) and part (11) with half moon washer (J) and nut (L) to lock them.

Step 12

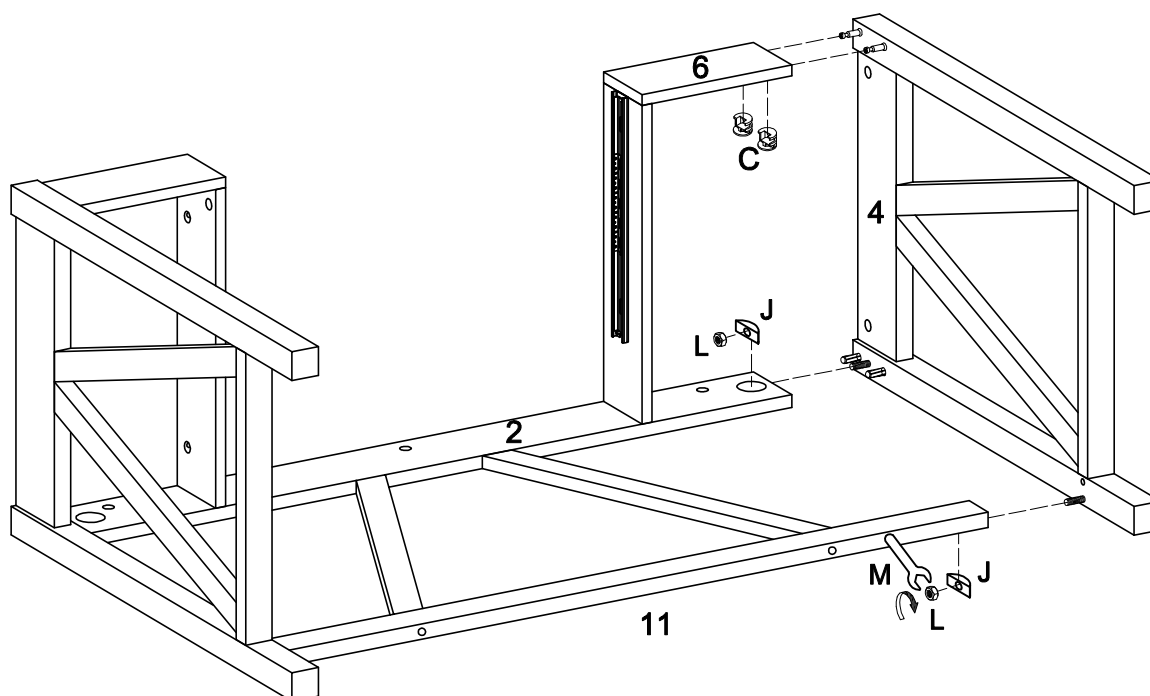
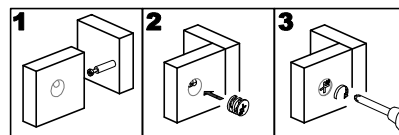

Insert side frame (4) into back panel (2) and parts (6,11), then insert and secure cam lock (C) to parts (6), and use wrench (M) to secure back panel (2) and parts (11) with half moon washer (J) and nut (L) to lock them.

Step 13

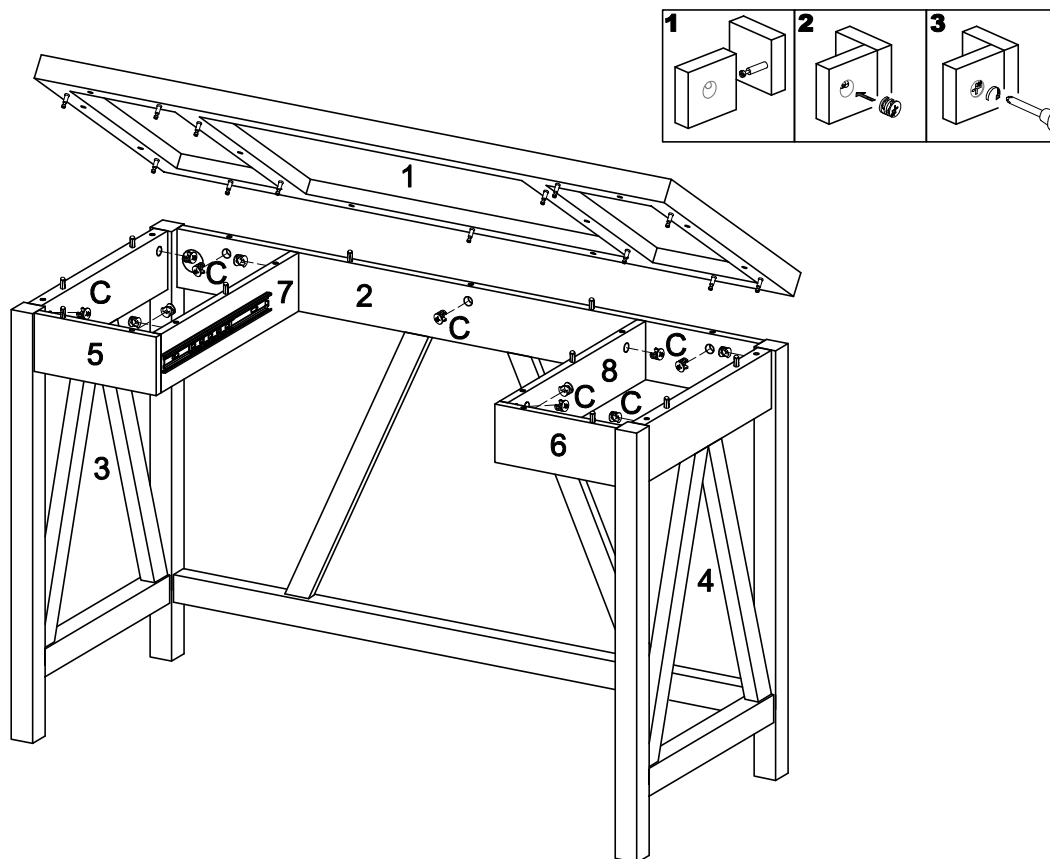

Insert top panel (1) into desk frame, then insert and secure cam lock (C) to back panel (2), side frame (3,4), side panel (7,8), and parts (5,6) to lock it.

Step 14

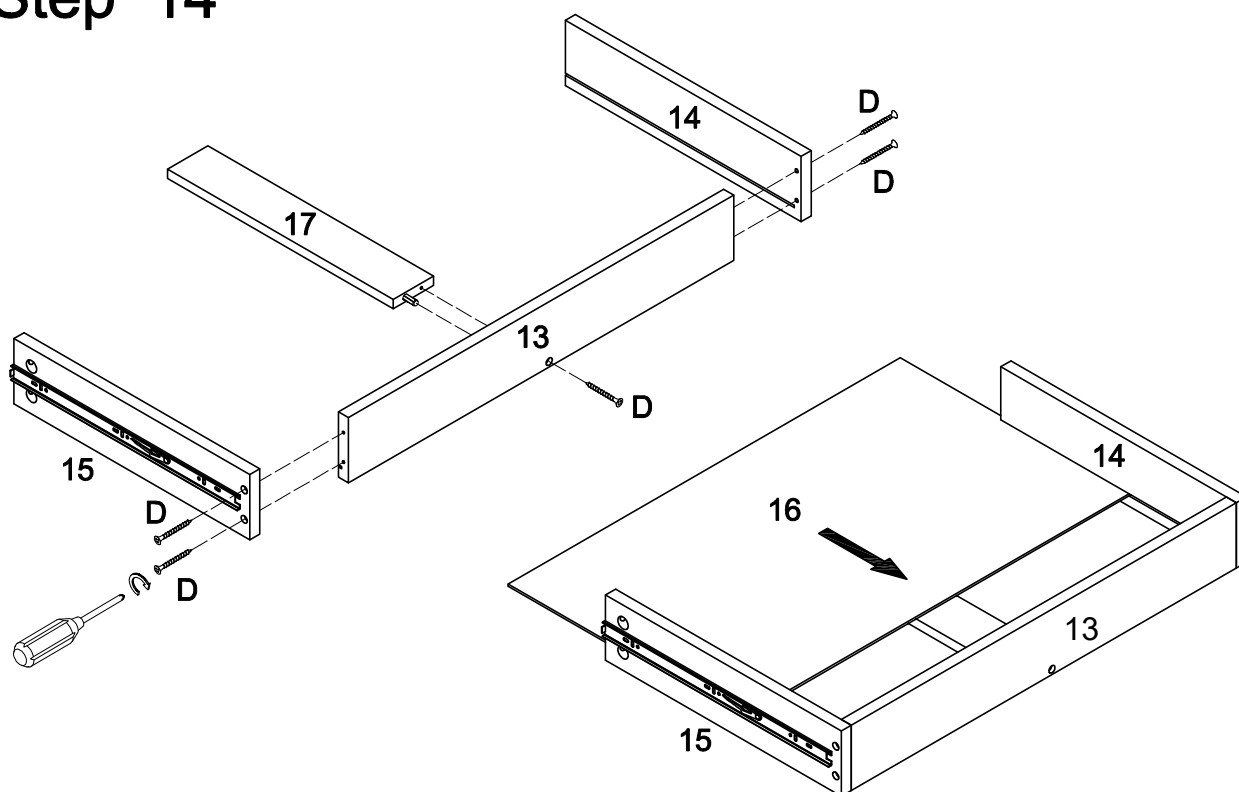

Insert parts (17) into drawer back panel (13) then secure it with screw (D). Secure drawer side panel (14,15) to drawer back panel (13) with screw (D). Slide drawer bottom panels (16) into grooves as per diagram.

Step 15

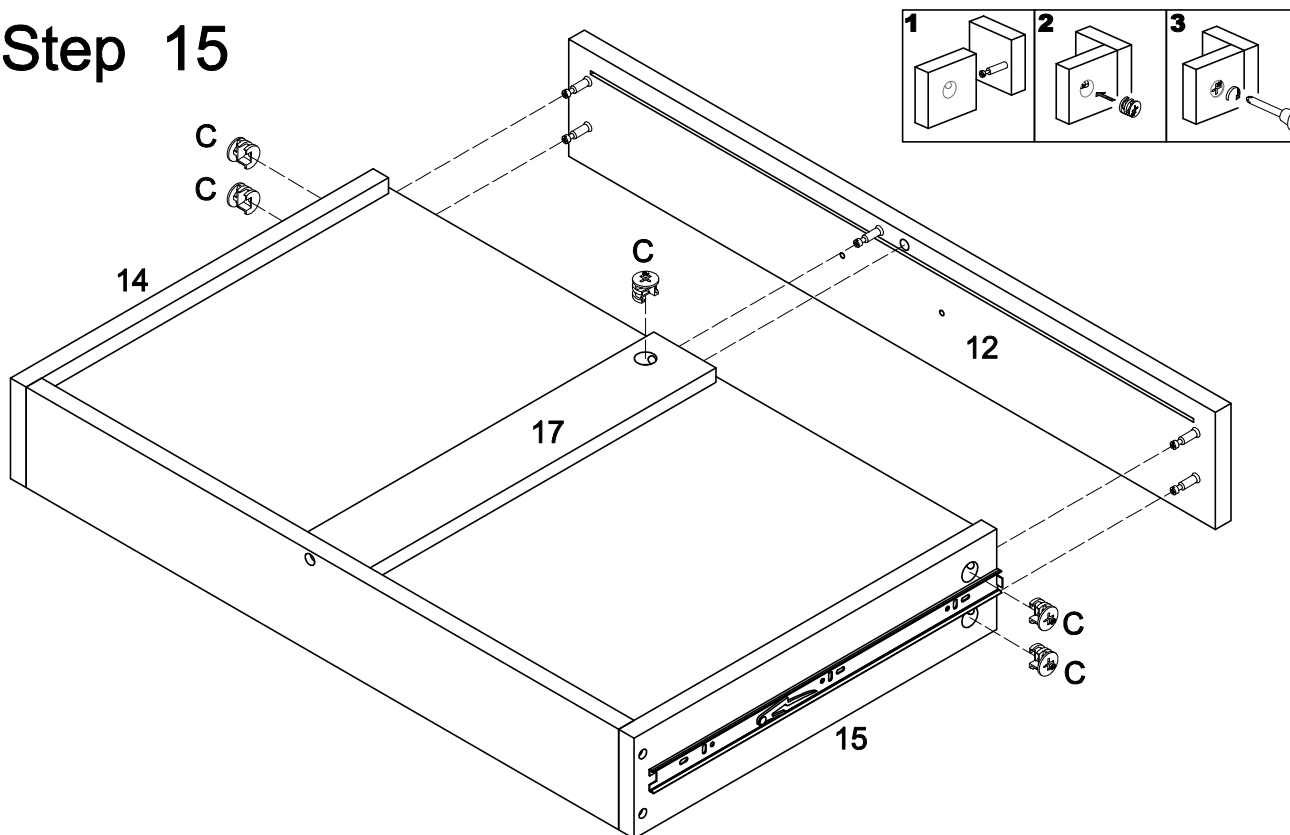

Insert drawer front panel (12) into drawer side panel (14,15) and parts (17), then insert and secure cam lock (C) to drawer side panel (14,15) and parts (17) to lock it.

Step 16

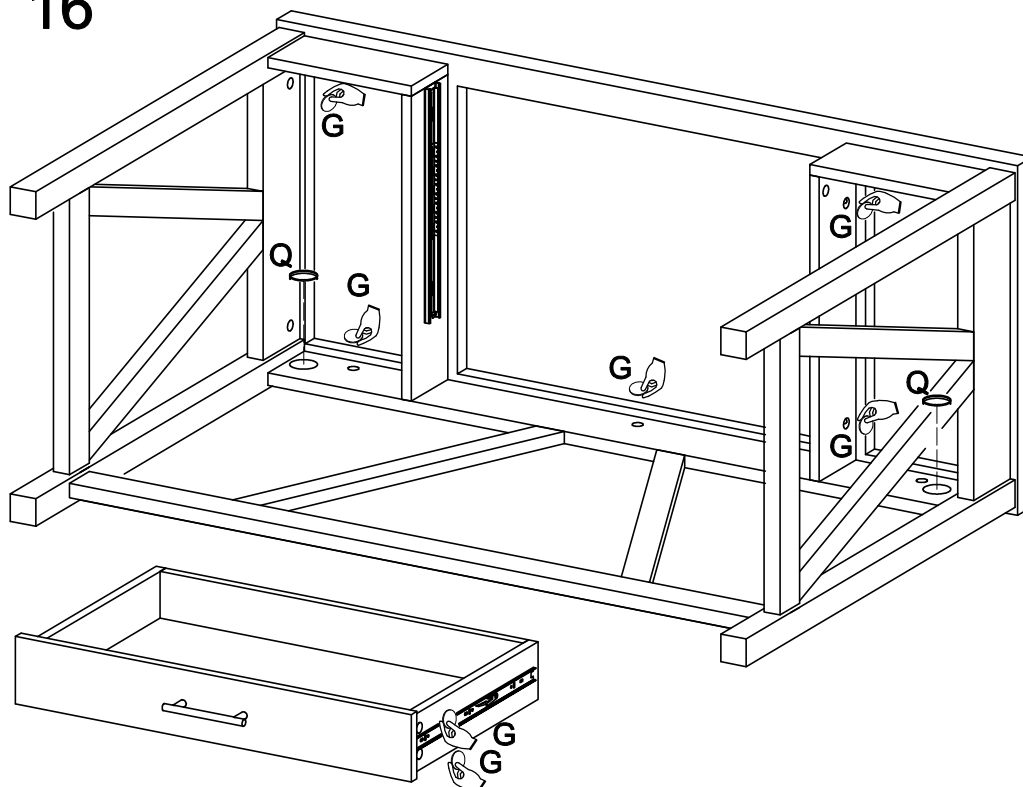

Place sticker (G) and plastic cover (Q) over holes as per diagram.

Step 17

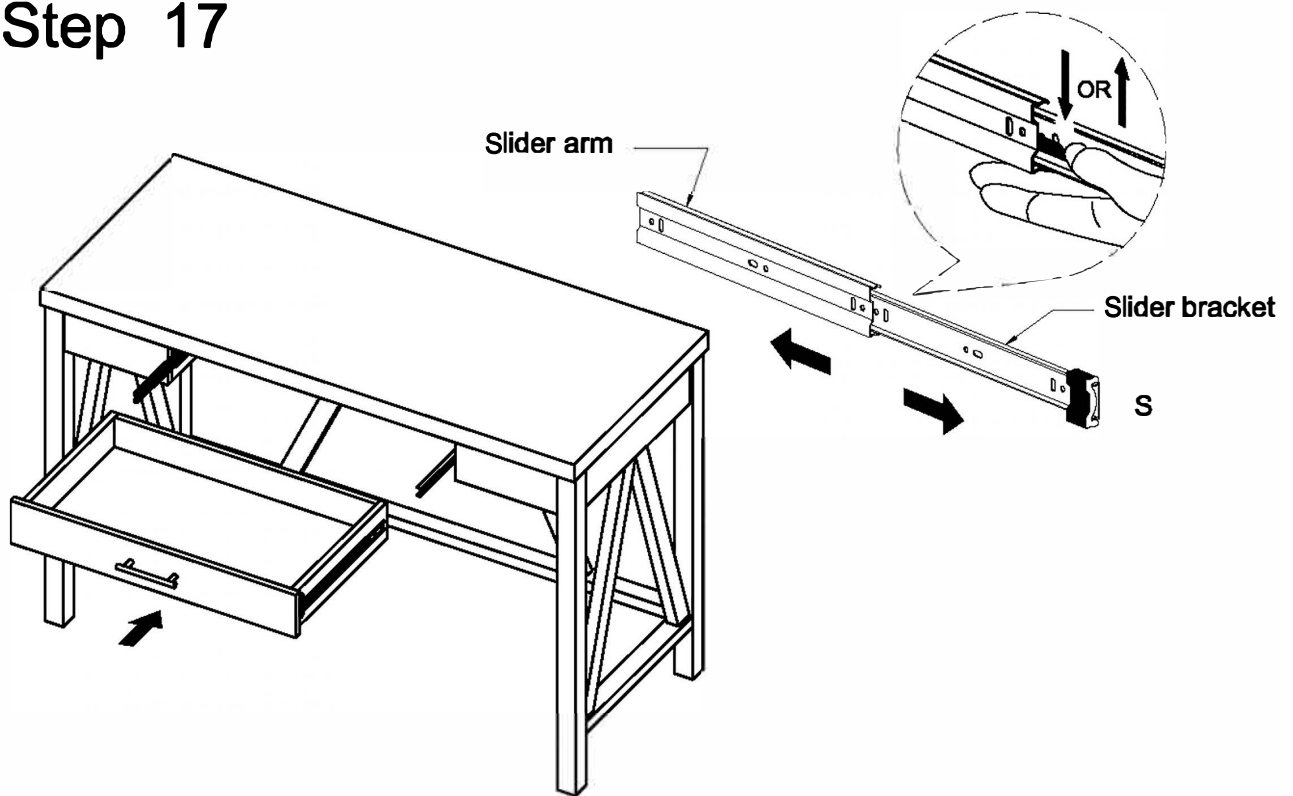

Press down/up the slider lock on slider bracket, then insert the drawer into slider arm to lock it.

Step 18

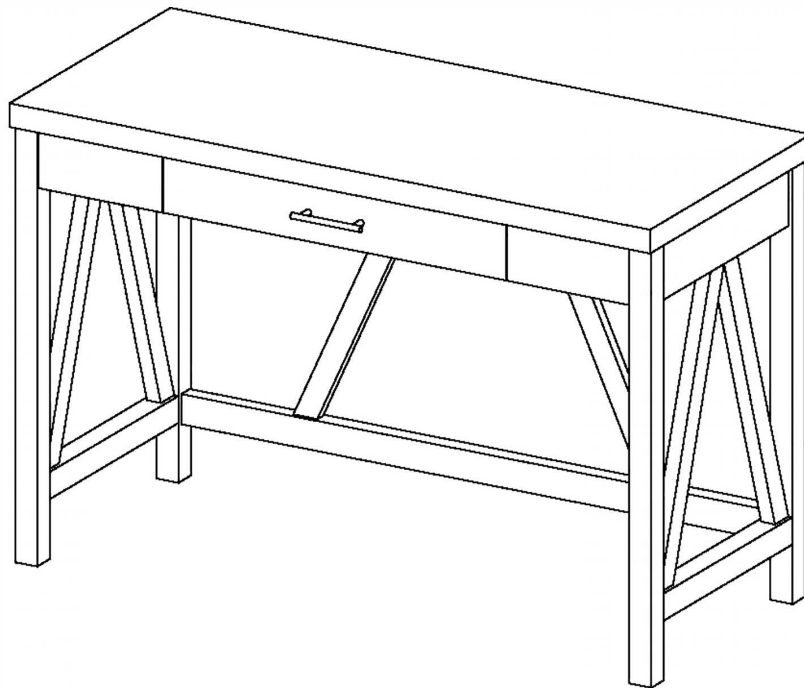

Final Assembly