

Assembly Instructions

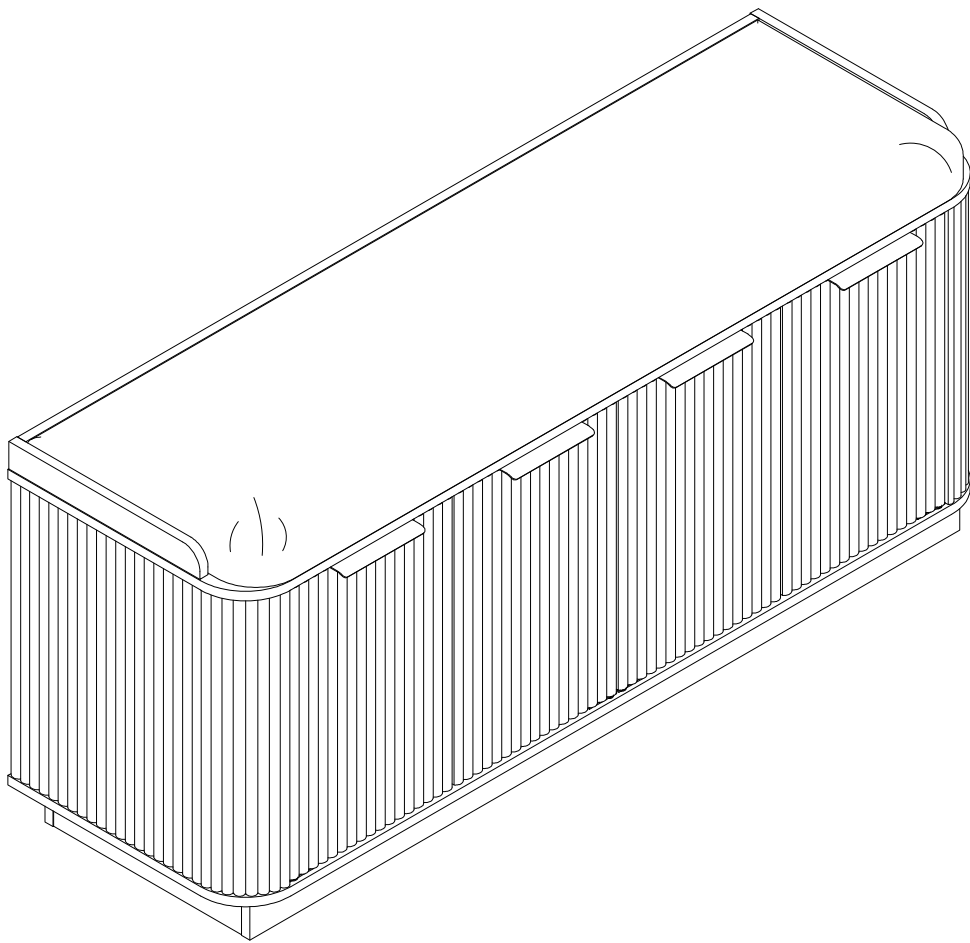

Before Assembly

Tips Before Your Start:

- Remove all wrapping material, including staples & packing straps before you start to assemble.
- DO NOT tighten all screws and bolts until the assembly is completely assembled.
- Keep all hardware parts out of reach of children.

QUICKFIT

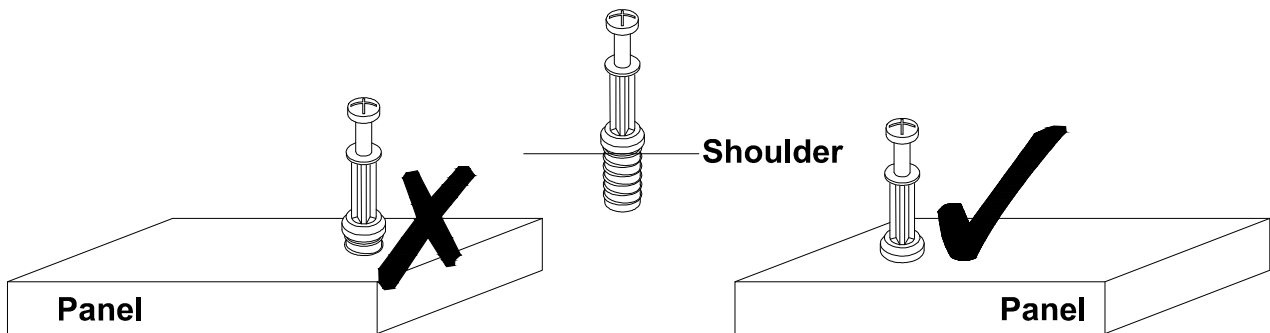

Tighten quickfit until shoulder is flush with panel. Do not overtighten or undertighten.

CAM LOCK

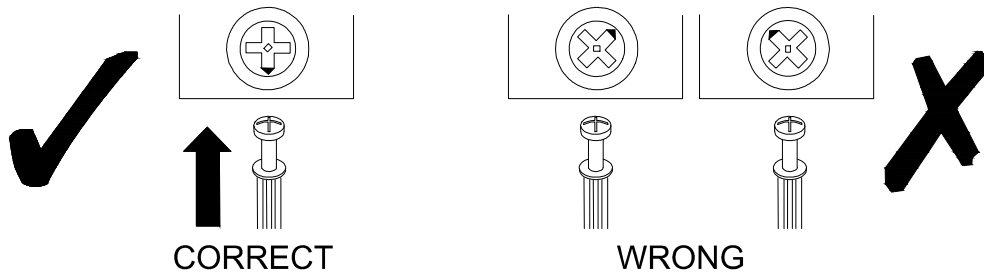

When fitting a cam lock, ensure the starting position is correct before inserting the connecting QUI CKFIT





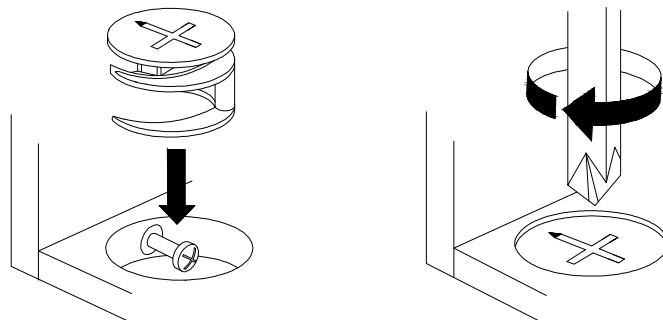

Quickfit head should be in the centre of the cam lock when the two panels are joined.

Cam lock should be inserted before quickfit.

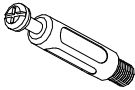

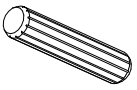
Turn cam lock clockwise to tighten.

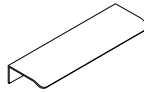
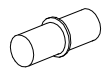
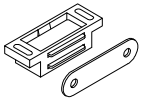
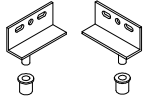
Part List

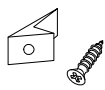
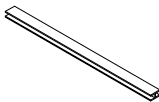
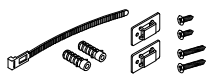
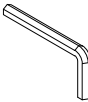
<p>No. A Quantity:21 Pcs Cam Lock Dowel 8*28mm</p> 	<p>No. B Quantity:21 Pcs Cam φ15</p> 	<p>No. C Quantity:21 Pcs Sticker Ø20</p> 	<p>No. D Quantity:18 Pcs Dowel 8*30mm</p> 
<p>No. E Quantity:48 Pcs Screw 3.5*12mm</p> 	<p>No. F Quantity:17 Pcs Screw M6*40mm</p> 	<p>No. G Quantity:4 Pcs Handle</p> 	<p>No. H Quantity:8 Pcs Shelf Support M5*15mm</p> 
<p>No. I Quantity:4 Sets Magnetic Door Catcher</p> 	<p>No. J Quantity:4 Sets Door hinge</p> 	<p>No. K Quantity:6 Pcs Foot Pad Ø15*5</p> 	<p>No. L Quantity:8 Sets Plastic Wedge</p> 
<p>No. M Quantity:2 Pcs Backboard spline 370*11*6mm</p> 	<p>No. N Quantity:1 Sets Anti-falling Parts</p> 	<p>No. O Quantity:1 Pcs Allen Key 4#</p> 	

Product structure

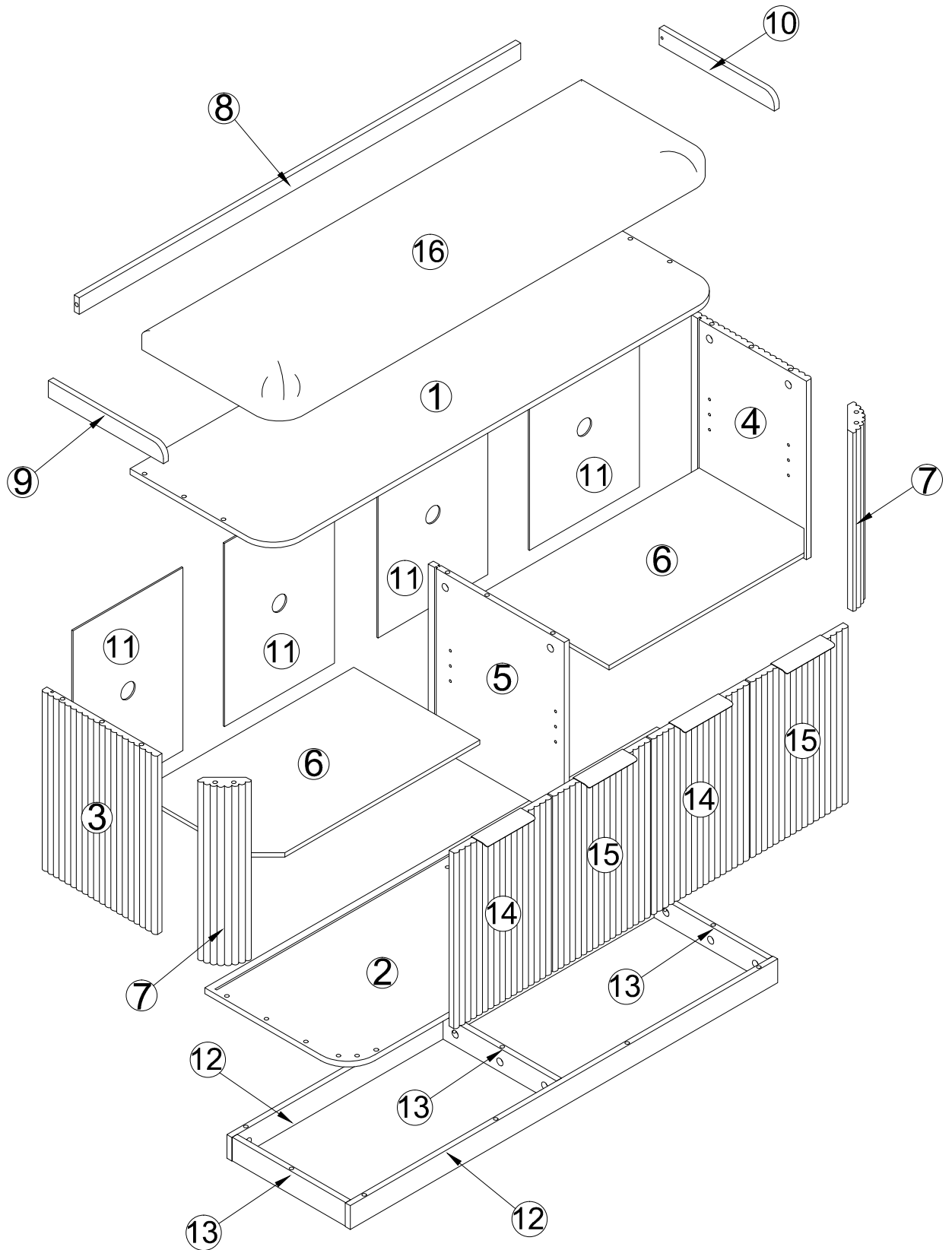

STEP 1

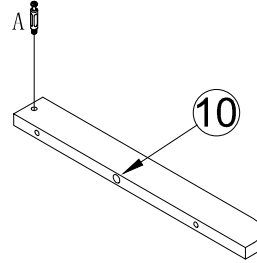
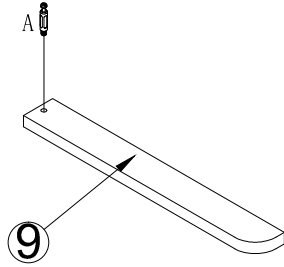

No. A
Quantity: 2 Pcs
8*28 mm



STEP 2

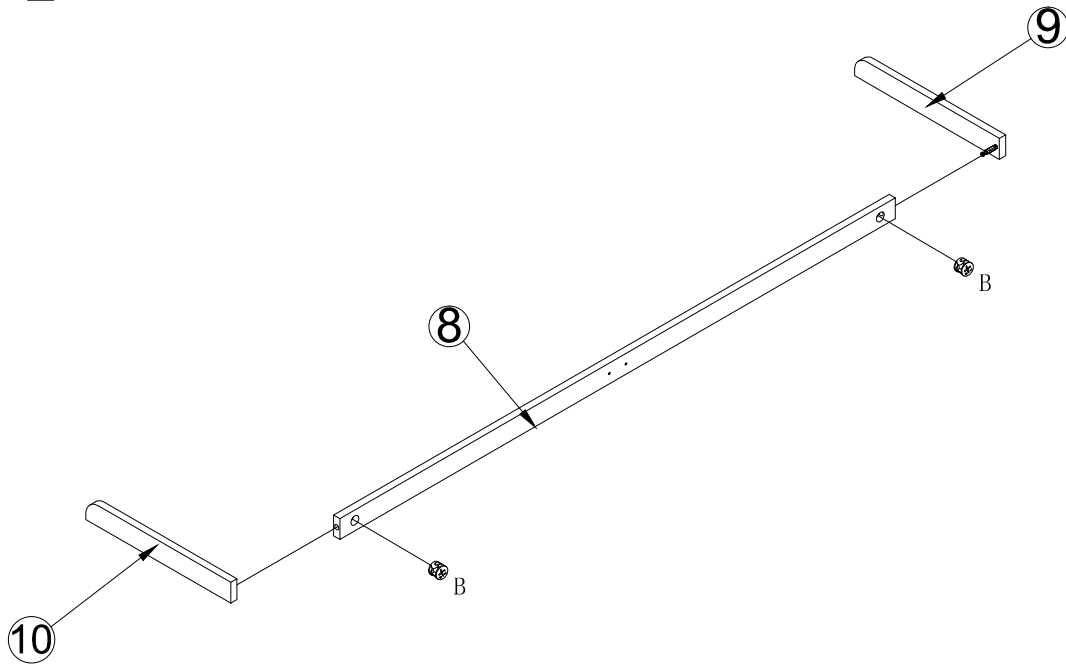

No. B
Quantity: 2 Pcs
Ø15



STEP 3

No. D
Quantity: 4 Pcs
8*30mm

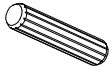

No. F
Quantity: 7 Pcs
M6*40mm



No. O
Quantity: 1 Pcs
4#

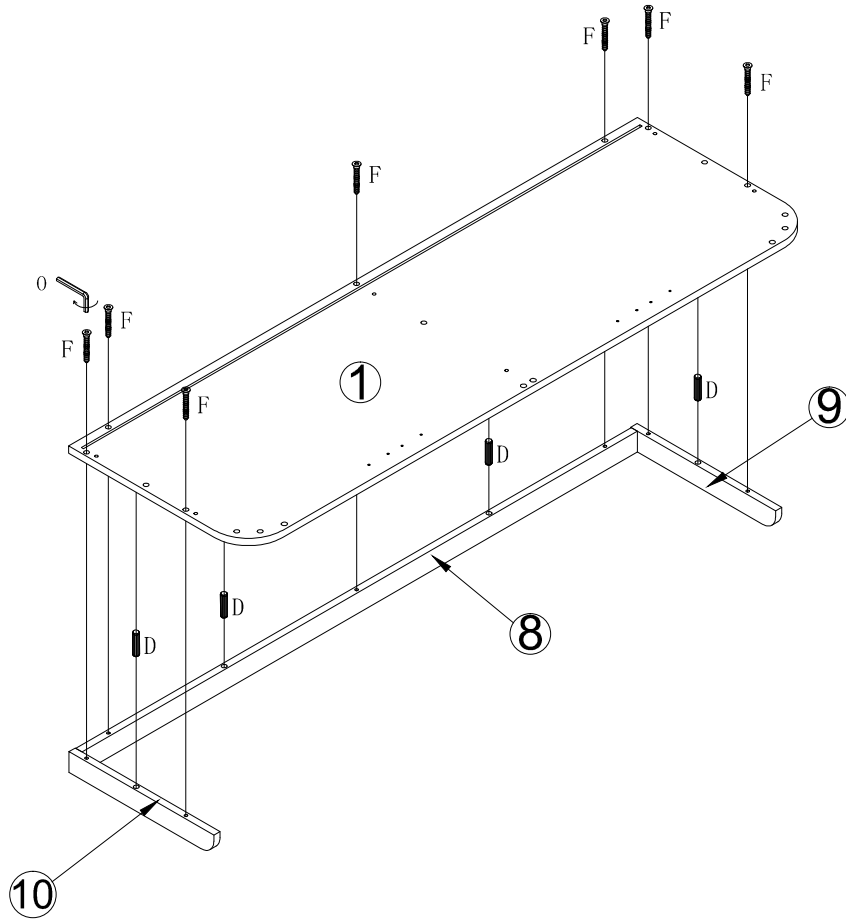

STEP 4

No. A
Quantity: 6 Pcs
8*28 mm



No. E
Quantity: 8 Pcs
3.5*12mm



No. I
Quantity: 4 Pcs

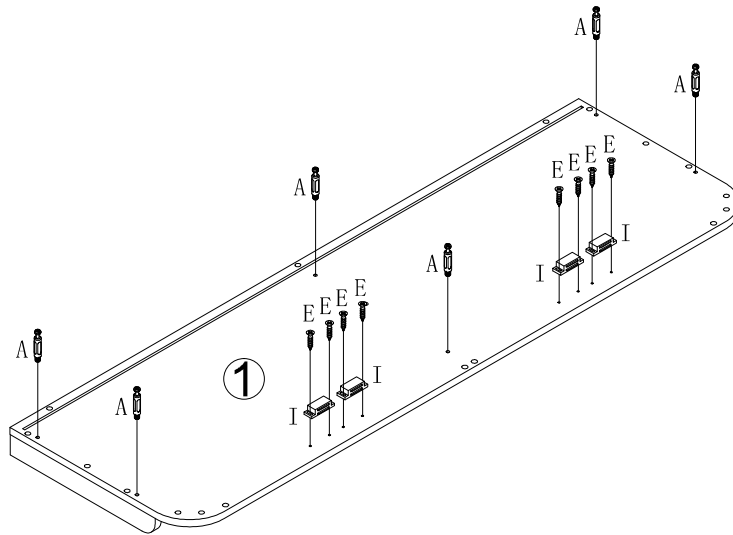
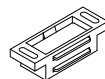

STEP 5

No. B
Quantity: 6 Pcs
Ø15



No. D
Quantity: 3 Pcs
8*30mm

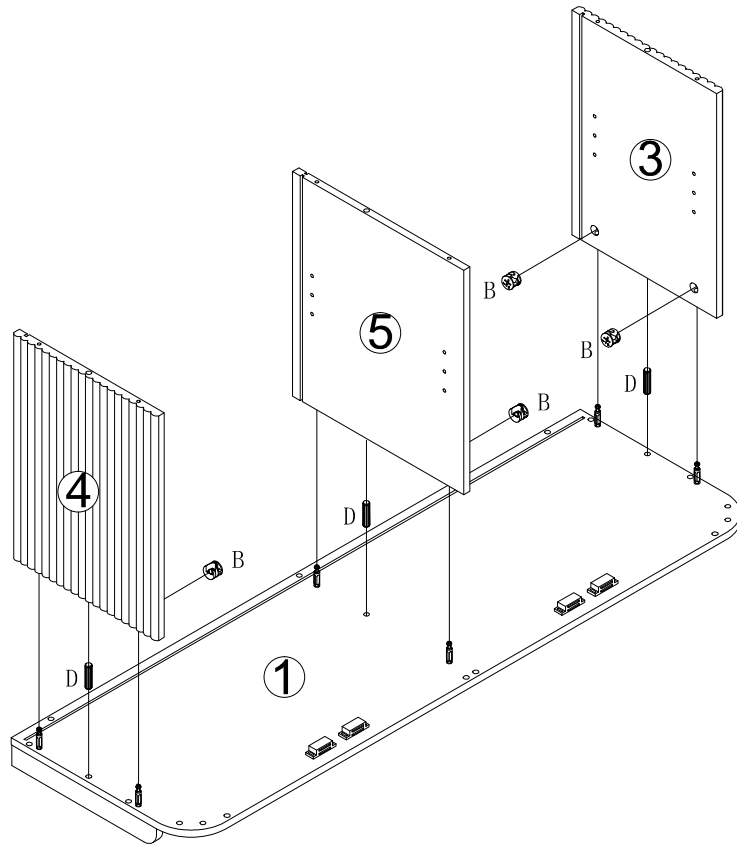
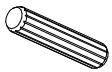

STEP 6

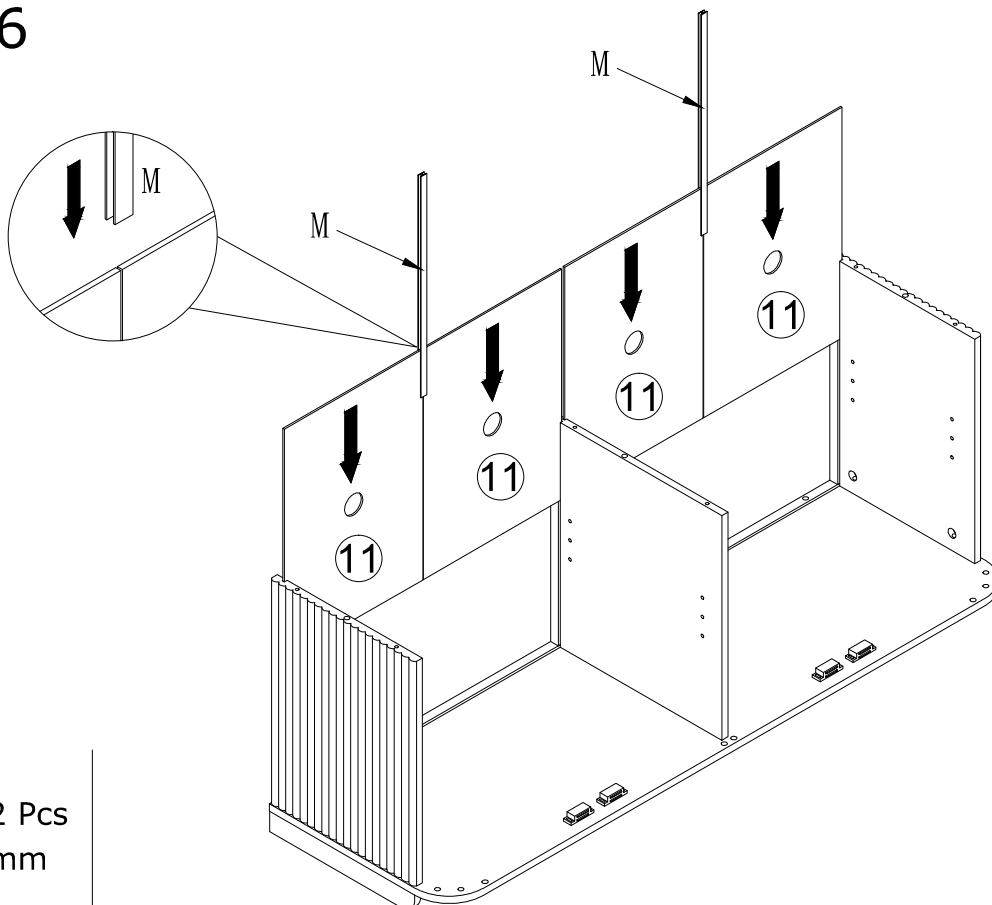

No. M
Quantity: 2 Pcs
370*11*6mm



STEP 7

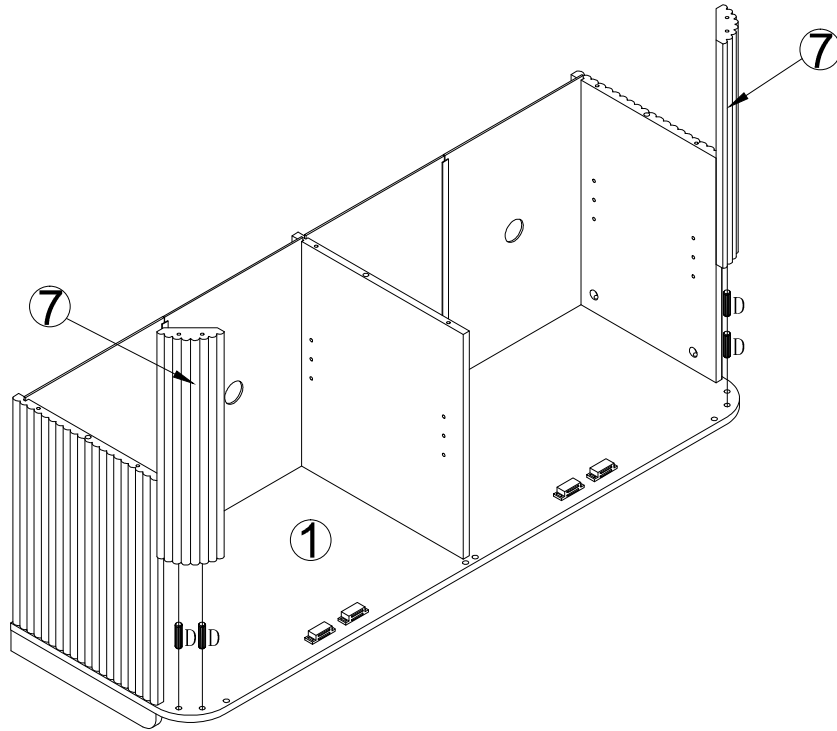

No. D
Quantity: 4 Pcs
8*30mm

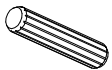

STEP 8

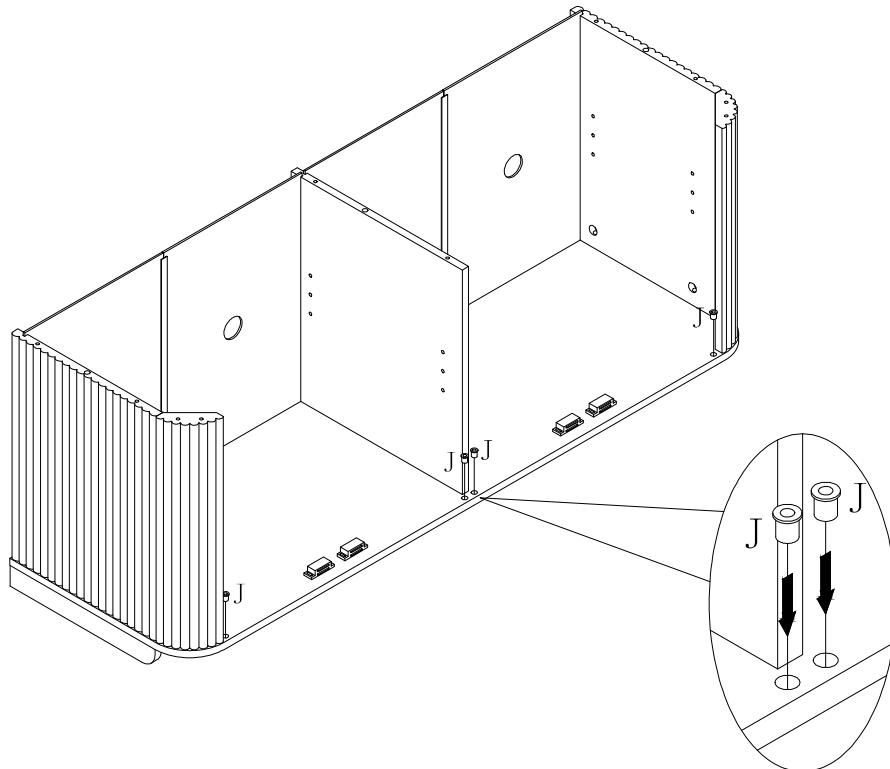

No. J
Quantity: 2 Sets



Note: Insert the black parts marked with J into the holes!

STEP 9

Note that the part with the marking "J" needs to be installed in pairs, and pay attention to the direction.

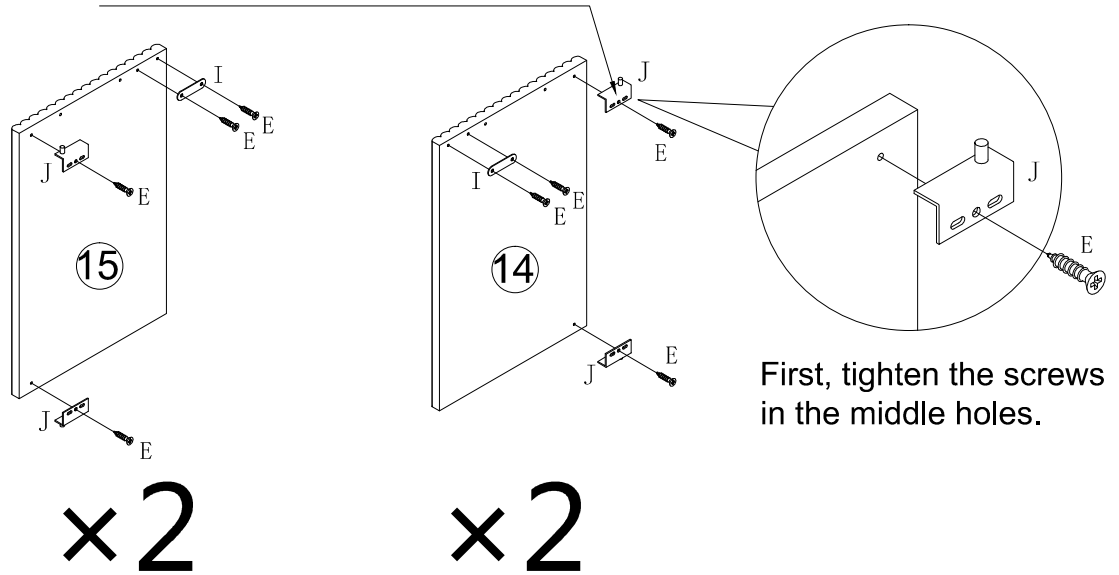

First, tighten the screws in the middle holes.

No. E
Quantity: 16 Pcs
3.5*12mm



No. I
Quantity: 4 Pcs

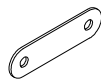

No. J
Quantity: 4 Sets

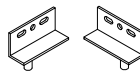

STEP 10

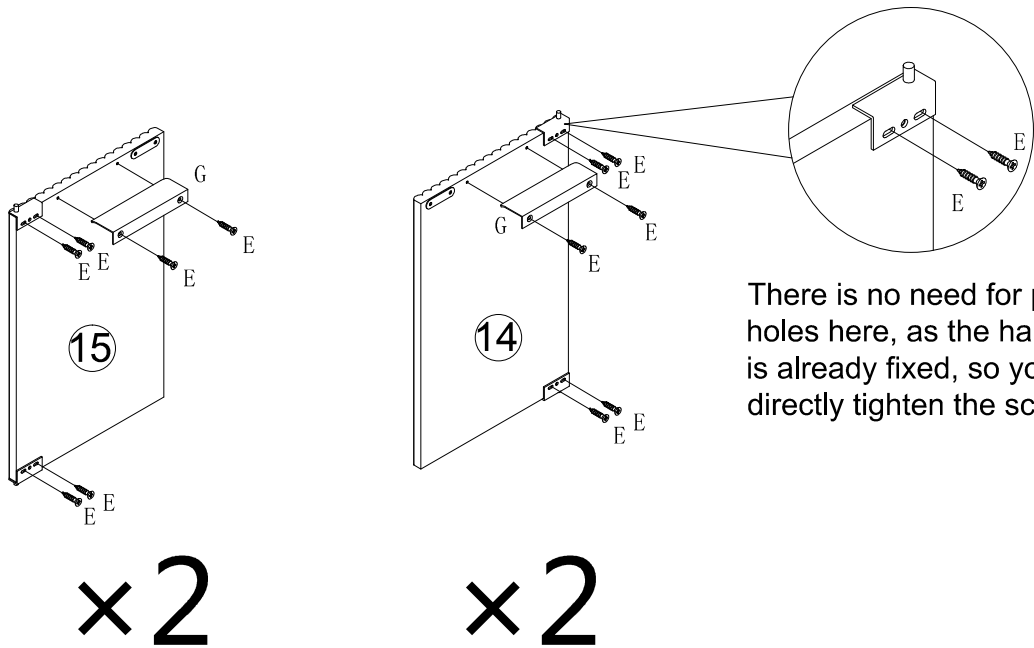

There is no need for pilot holes here, as the hardware is already fixed, so you can directly tighten the screws.

No. E
Quantity: 24 Pcs
3.5*12mm



No. G
Quantity: 4 Pcs

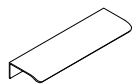

STEP 11

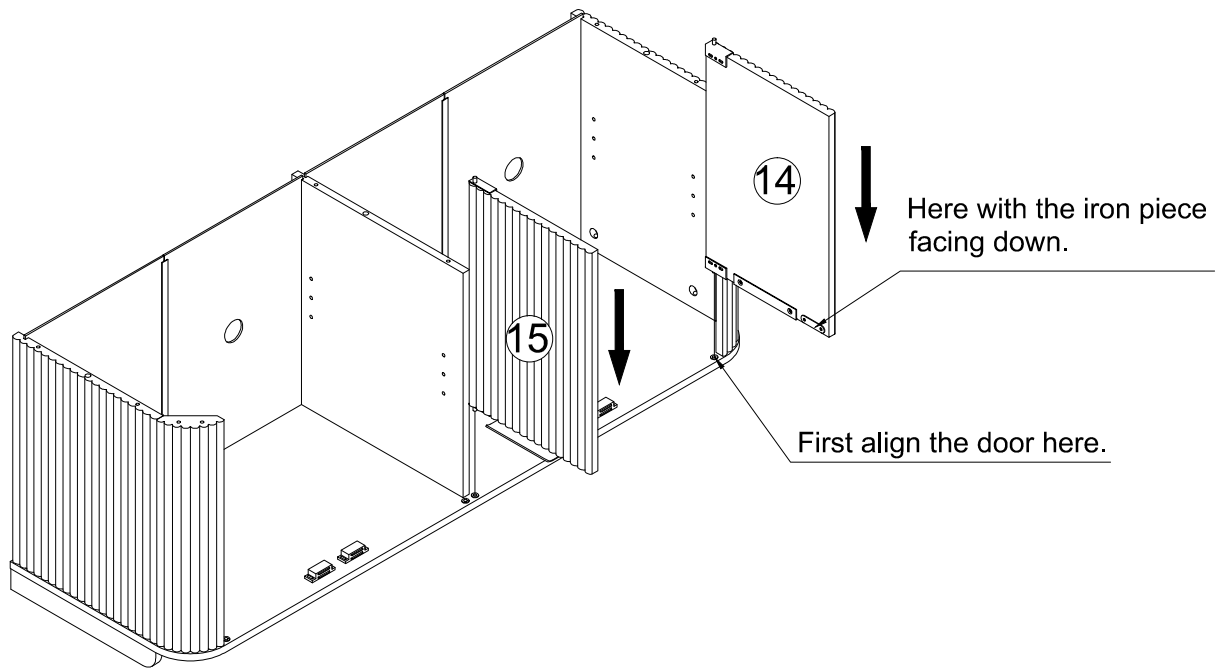

STEP 12

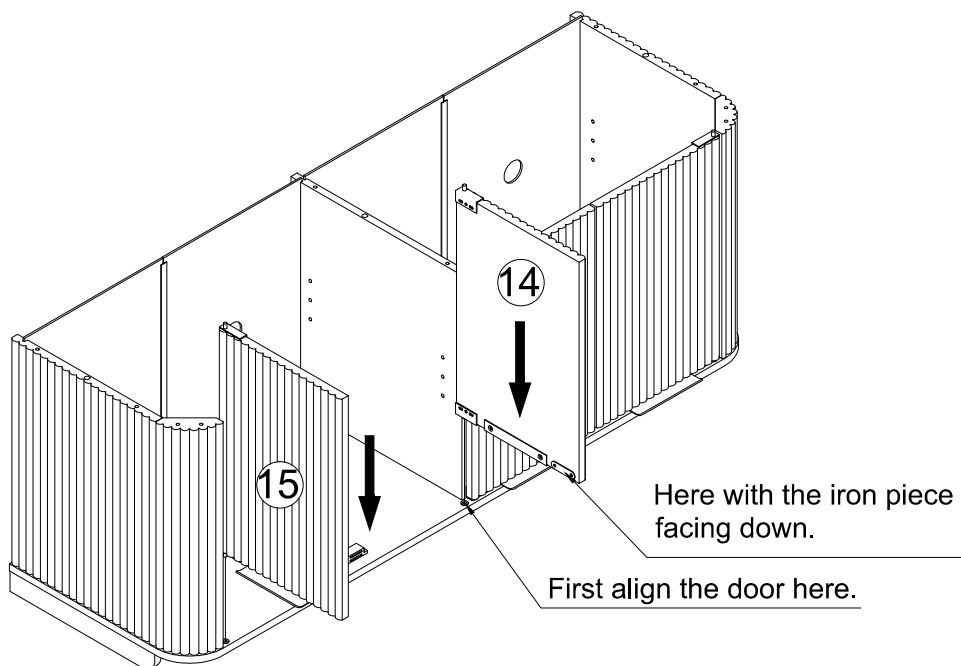

STEP 13

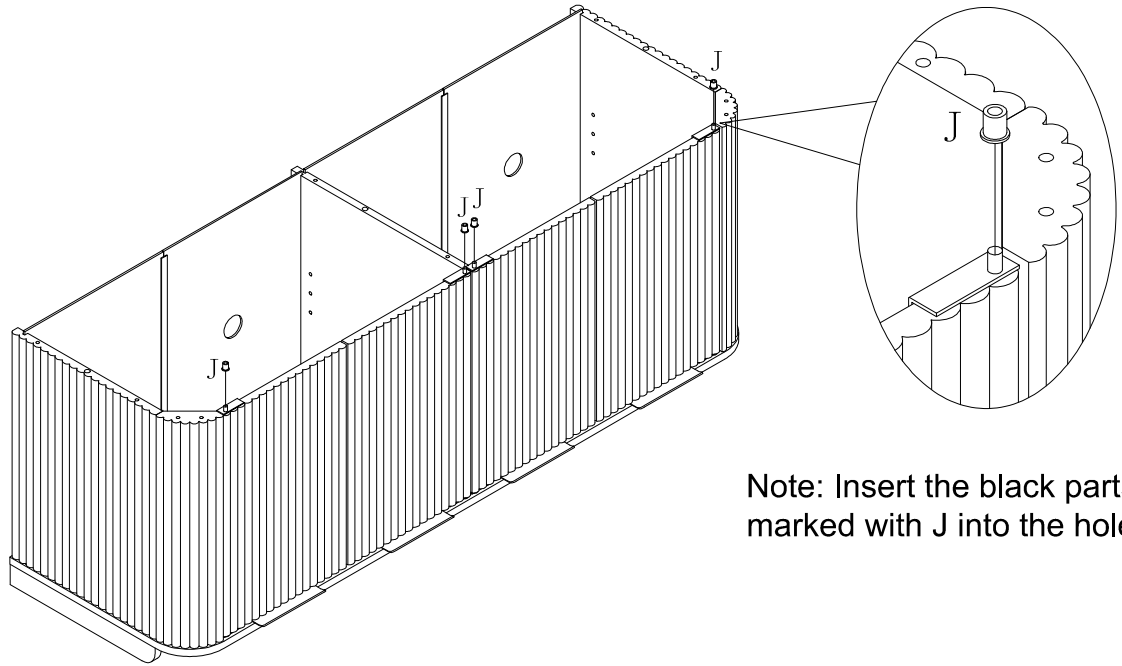

Note: Insert the black parts marked with J into the holes!

No. J
Quantity: 2 Sets

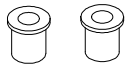

STEP 14

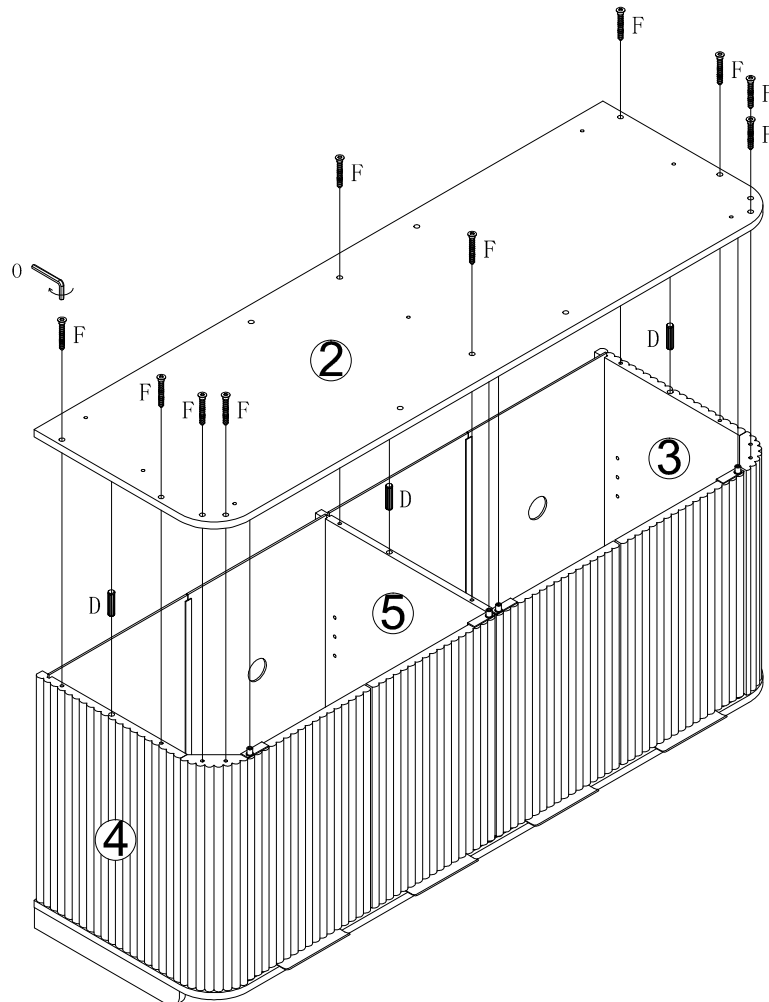

No. D
Quantity: 3 Pcs
8*30mm

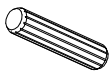

No. F
Quantity: 10 Pcs
M6*40mm



No. O
Quantity: 1 Pcs
4#



STEP 15

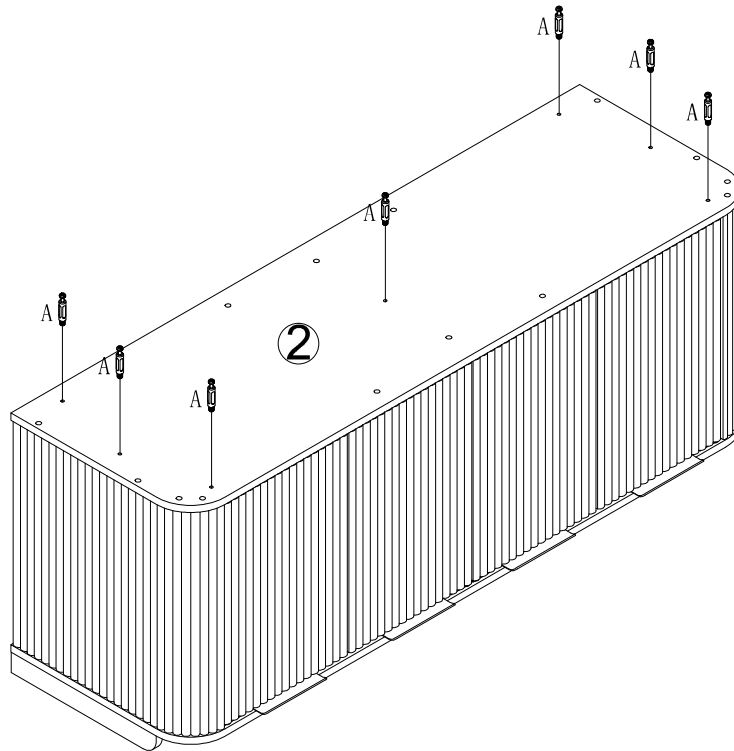

No. A
Quantity: 7 Pcs
8*28 mm



STEP 16

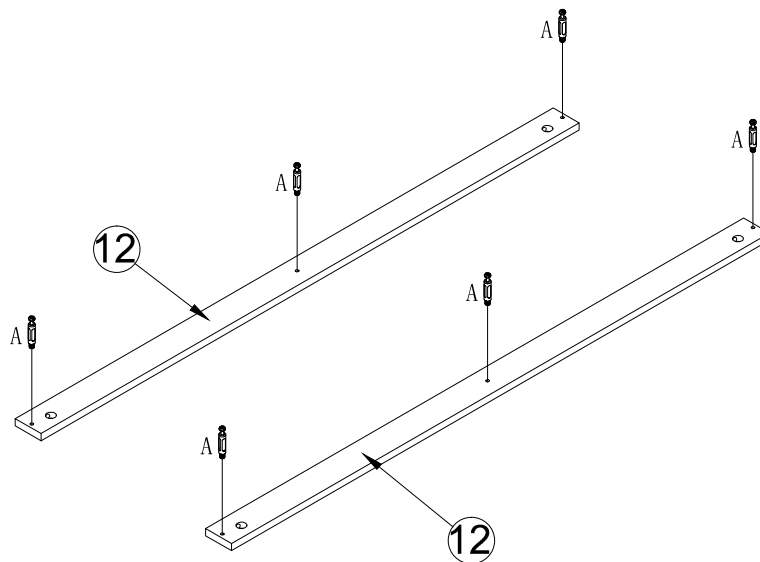

No. A
Quantity: 6 Pcs
8*28 mm



STEP 17

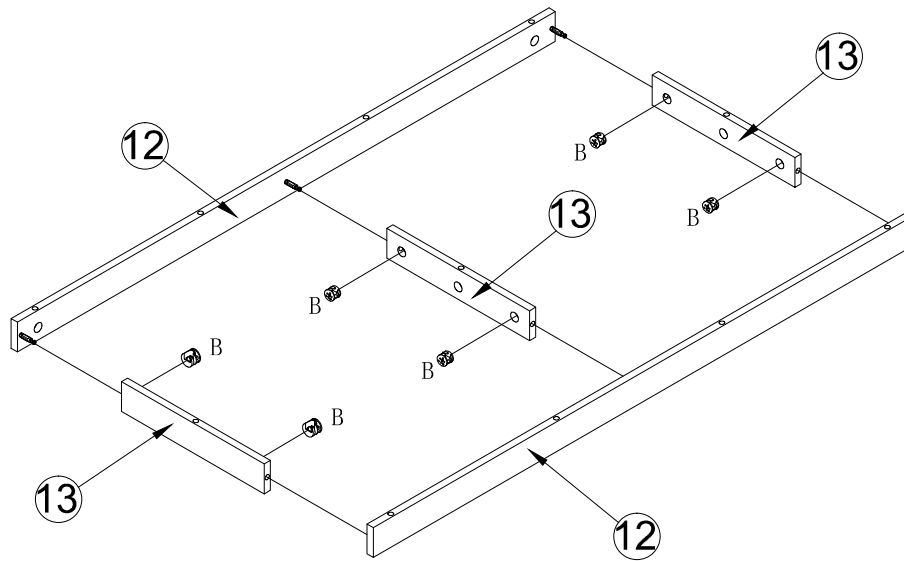

No. B
Quantity: 6 Pcs
Ø15



STEP 18

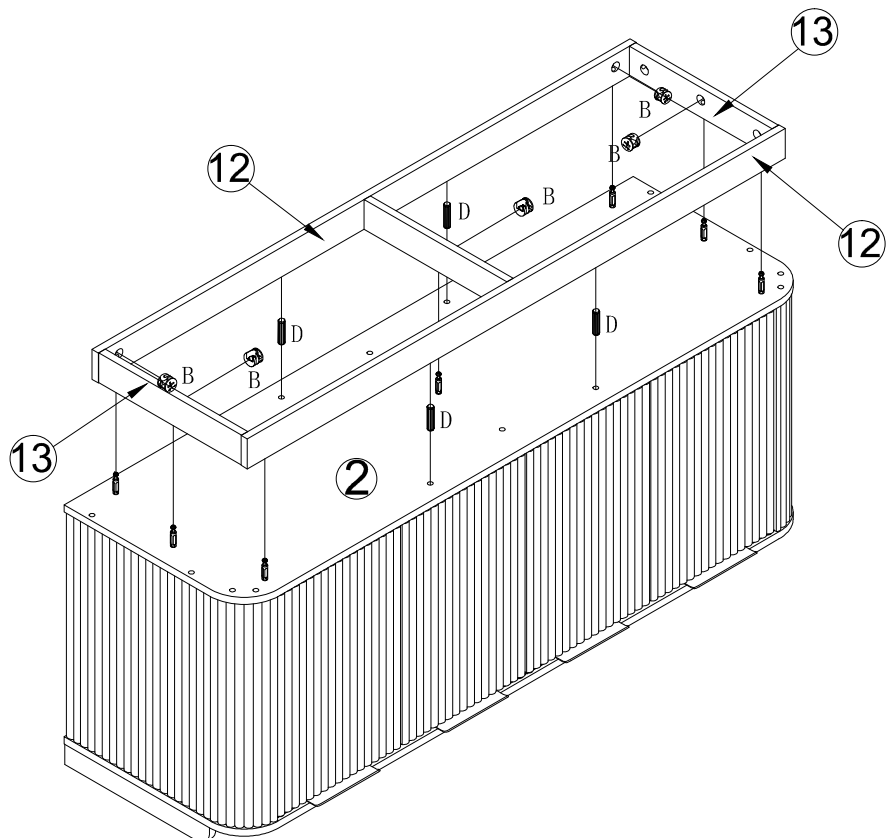

No. B
Quantity: 7 Pcs
Ø15



No. D
Quantity: 4 Pcs
8*30mm



STEP 19

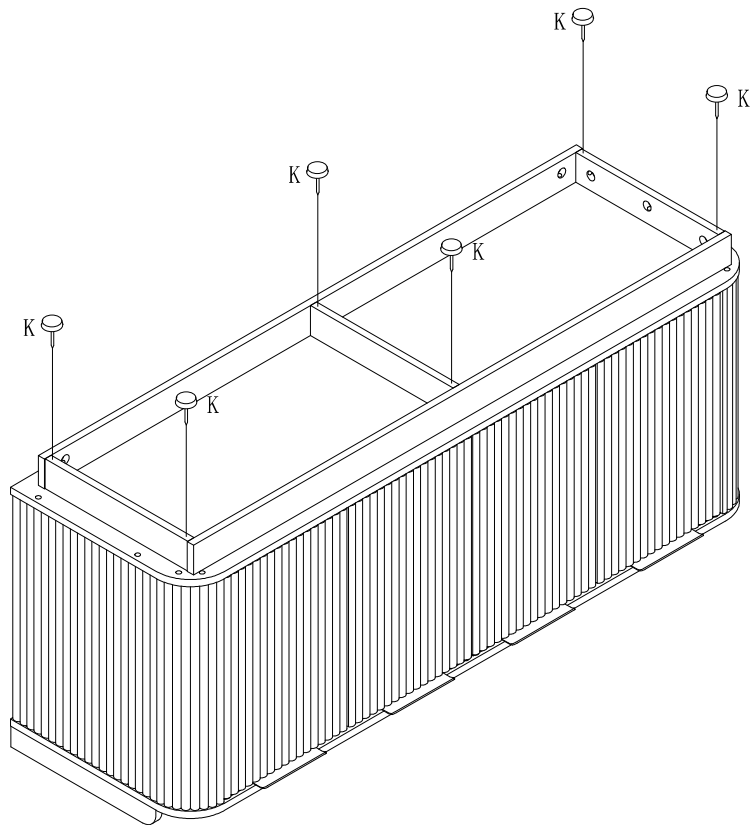

No. K
Quantity: 6 Pcs
Ø15*5



STEP 20

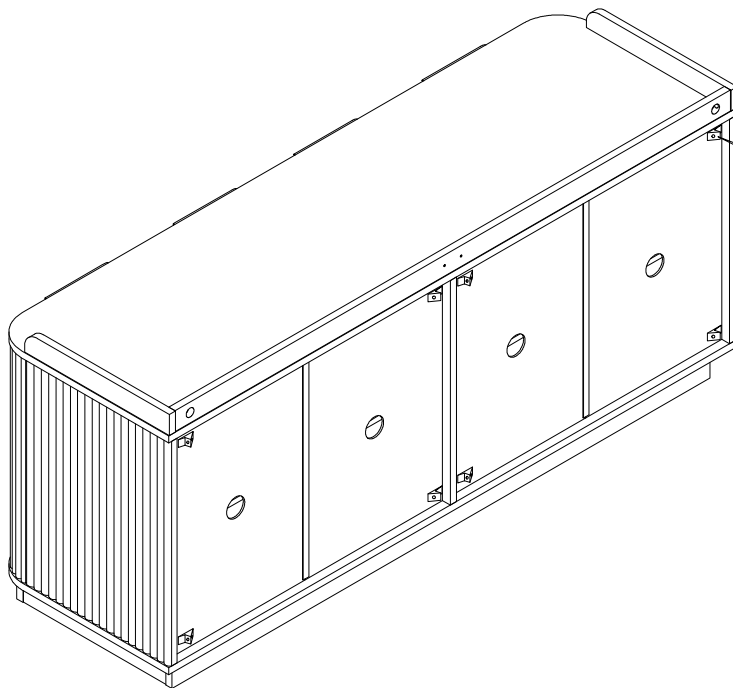

Description: Insert the thinner end of the reinforcement into the gap in this back panel, then tighten the screws. This will make the cabinet more stable.

No. L
Quantity: 8 Pcs

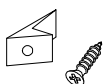

STEP 21

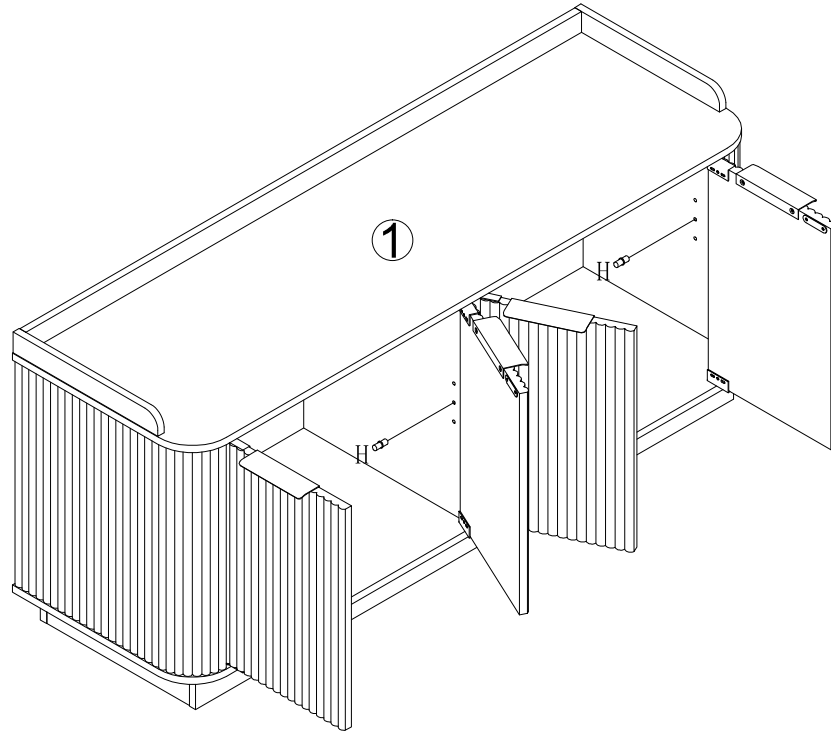

No. H
Quantity: 8 Pcs
M5*15mm



STEP 22

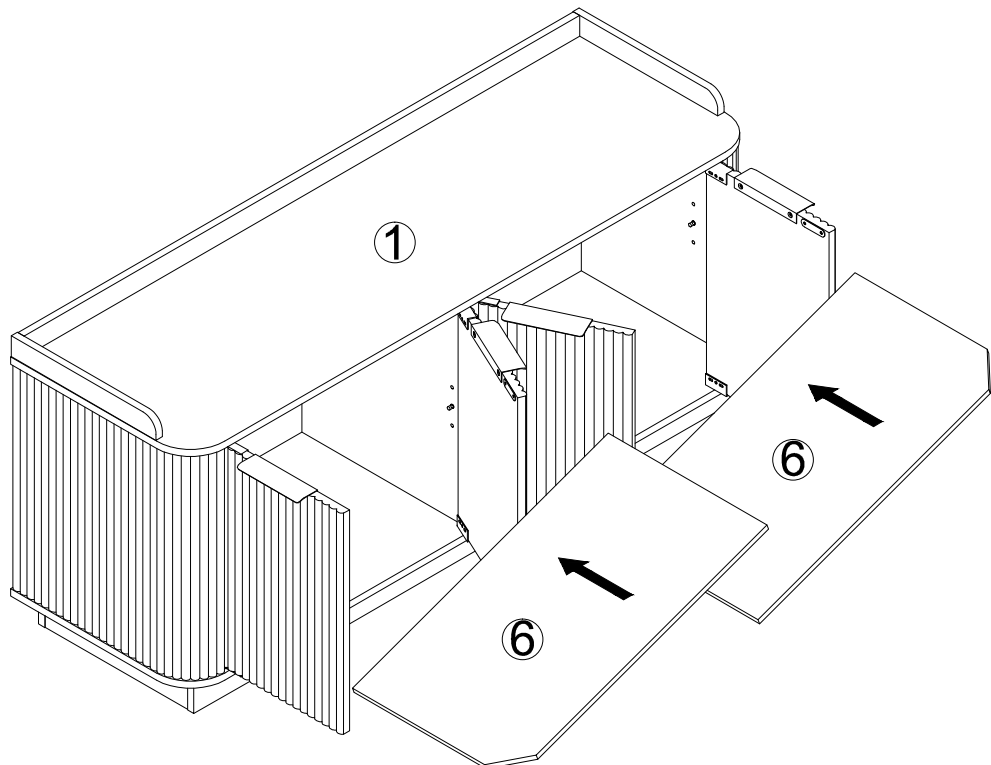

STEP 21

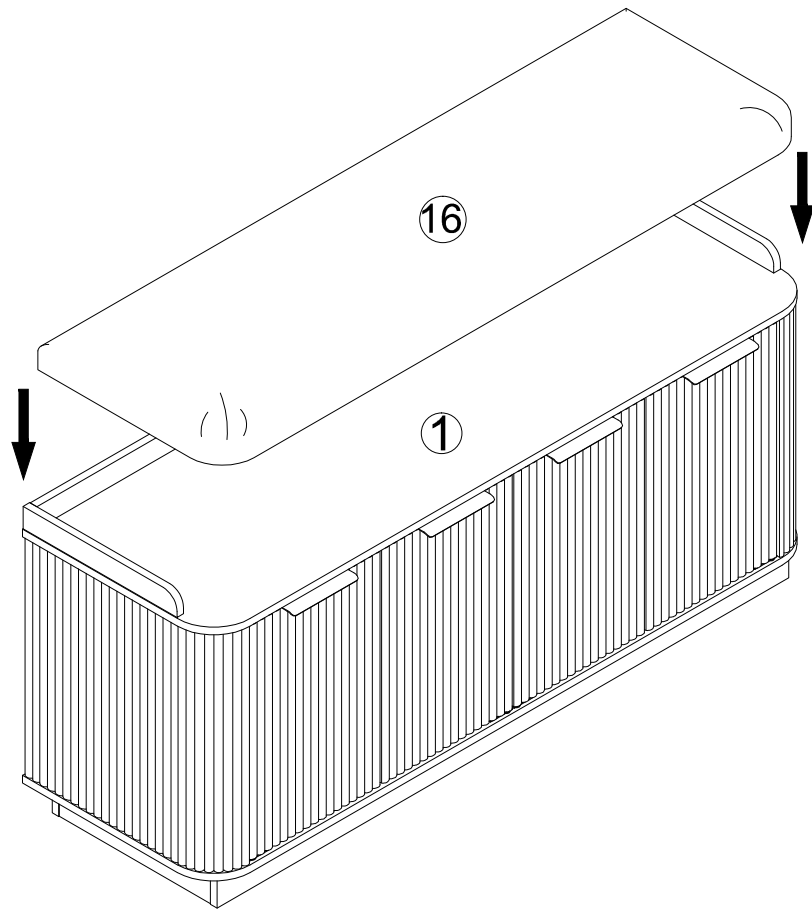

STEP 22

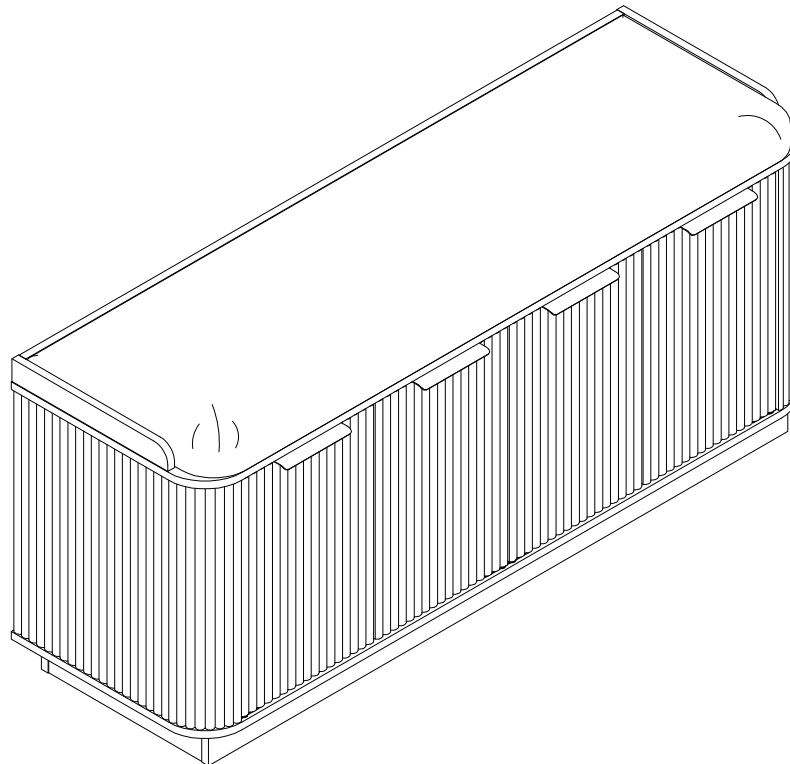

STEP 23

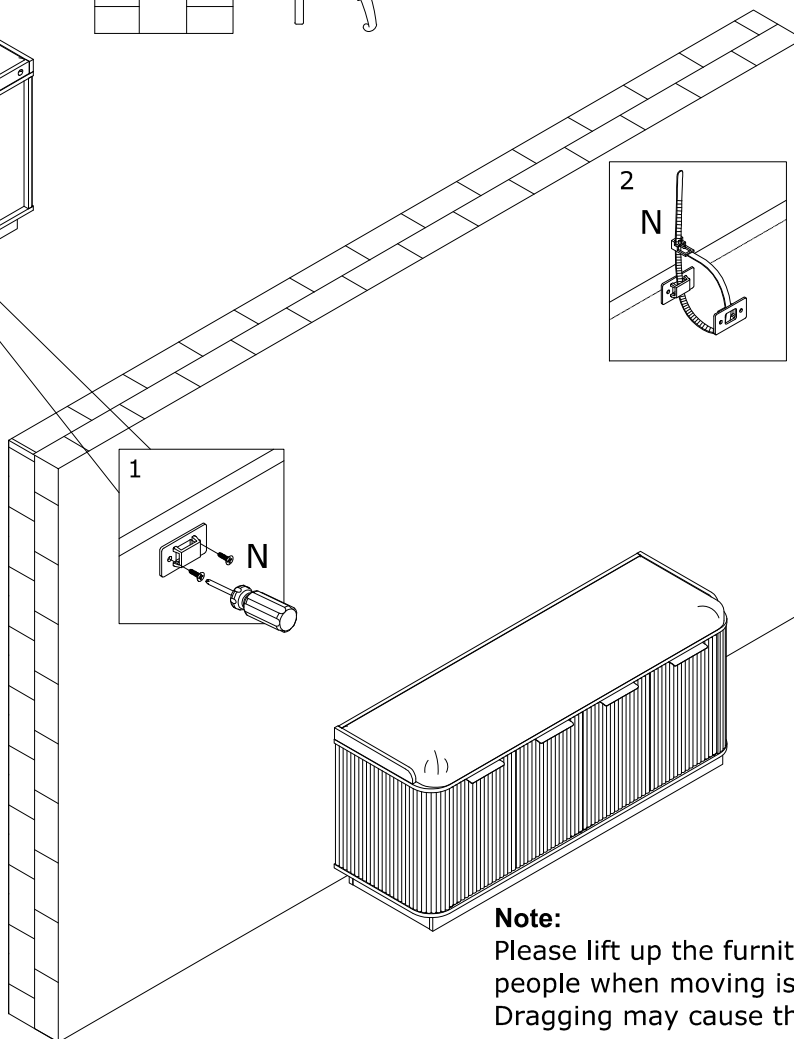
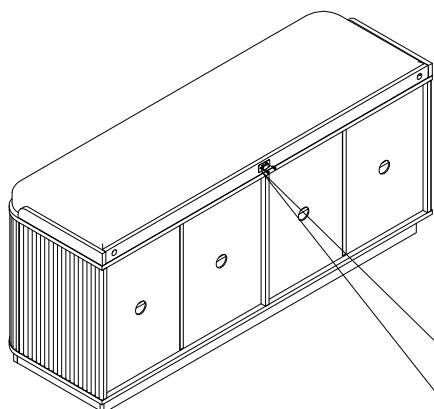
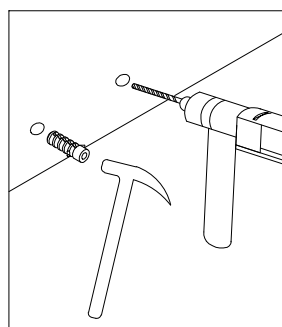
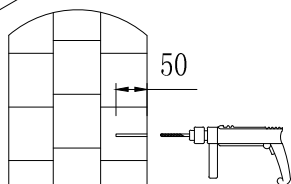
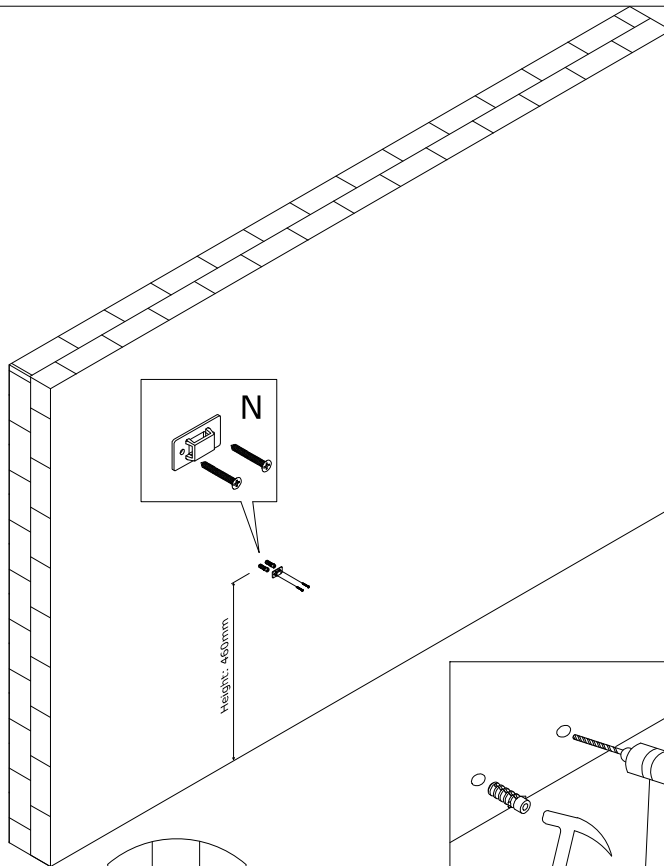

No. N
Quantity: 1 Set

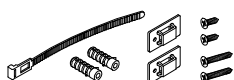

Note:
Please lift up the furniture by two people when moving is needed.
Dragging may cause the legs failure.