

IMPORTANT, RETAIN FOR FUTURE REFERENCE: READ CAREFULLY

ASSEMBLY INSTRUCTION

*Suitable for children of 3-12 years old.







*Max weight: 30 kg.

* Convient aux enfants de 3 à 12 ans.

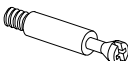
*Poids maximum : 30 kg

EN: **WARNING:** CHOKING HAZARD—Small parts. Not for children under 3 years.
Only allowed for adults to install, keep children away.

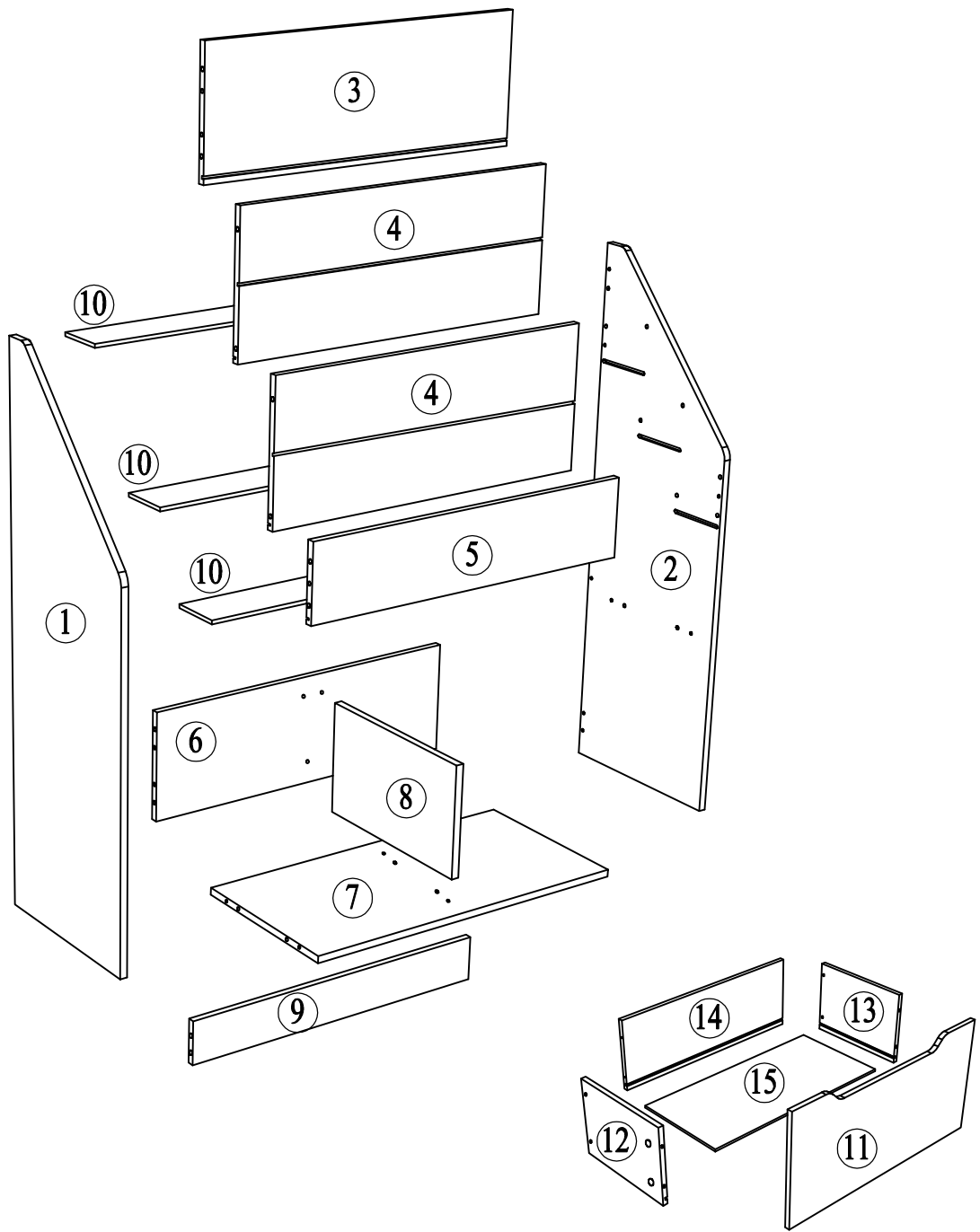

FR: **Attention:** Contient de petites pièces pouvant être dangereux pour les enfants moins de 3 ans. Seulement autorisé pour les adultes à installer, éloigner les enfants.

A  $\varnothing 12 \times 10 \text{mm}$ +1(spare) X 24	B  $\varnothing 6.5 \times 38 \text{mm}$ +1(spare) X 24	C  $\varnothing 6 \times 30 \text{mm}$ +1(spare) X 24	D  $12 \times 20 \text{mm}$ X 4	E  $M4 \times 30 \text{mm}$ +1(spare) X 8
F  X 4	G  X 1	H  $M3.5 \times 12 \text{mm}$ +1(spare) X 8		



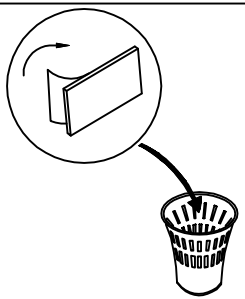
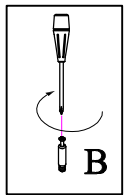
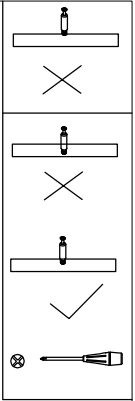
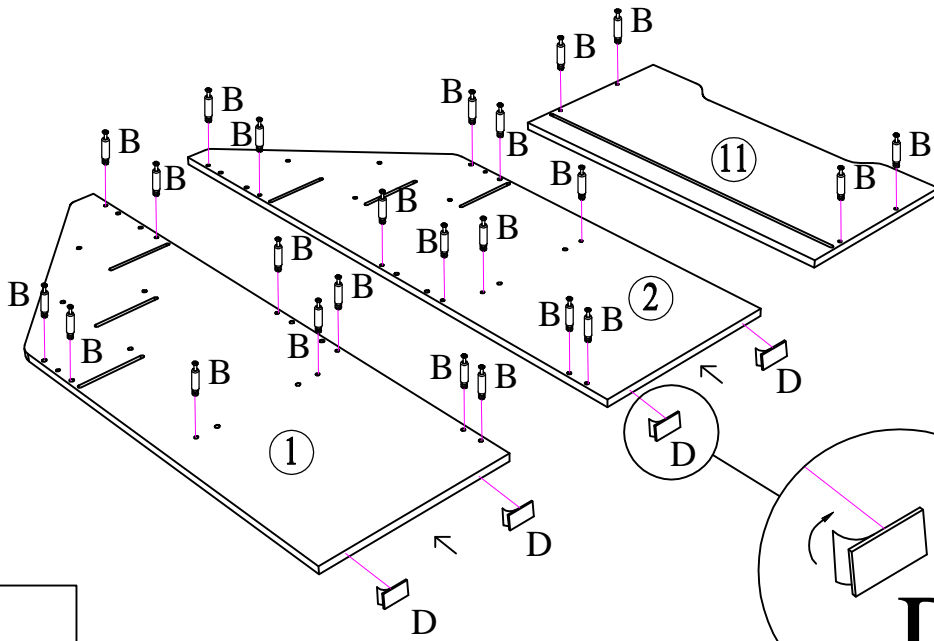

1

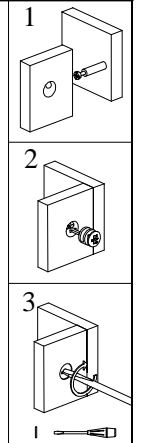
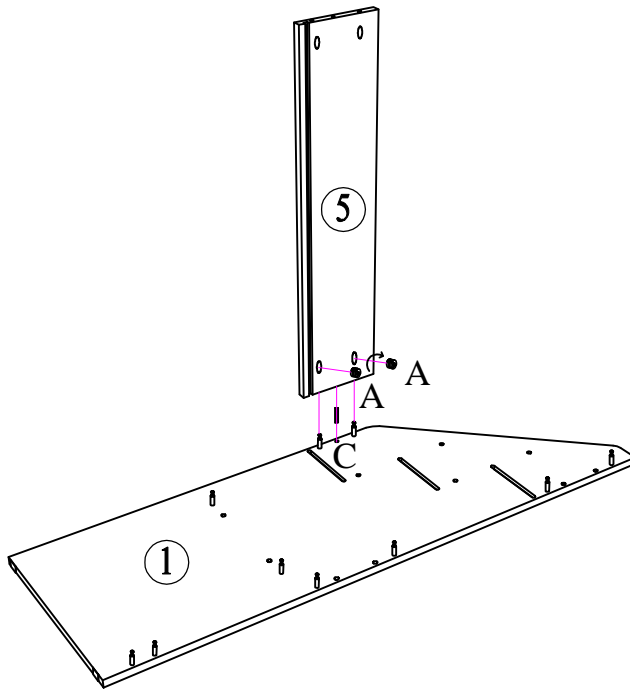

<p>D</p>  <p>12x 20mm</p> <p>x4</p>	<p>B</p>  <p>Ø6.5 x 38mm</p> <p>x24</p>
--	--

2



<p>C</p>  <p>Ø6 x 30mm</p> <p>x1</p>	<p>A</p>  <p>Ø12x10mm</p> <p>x2</p>
--	---

3

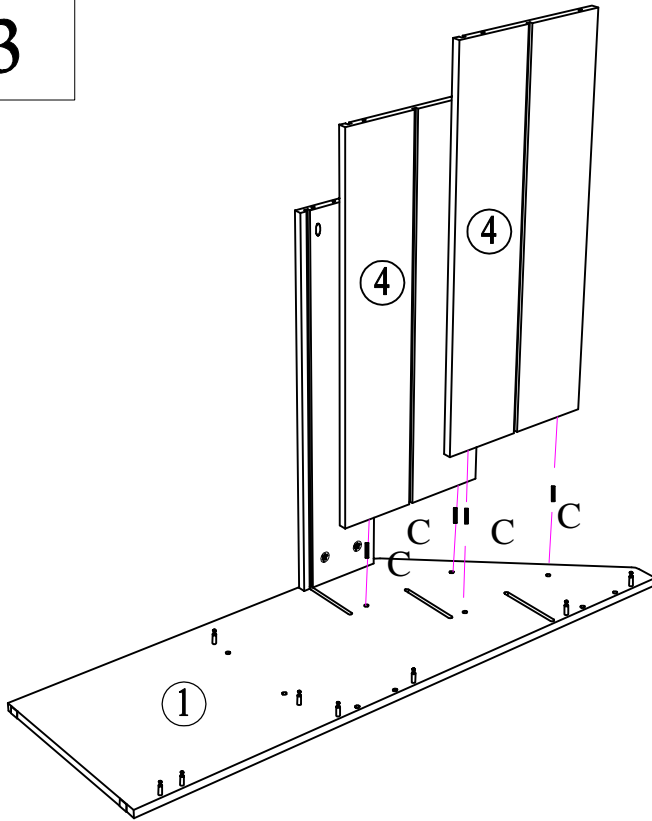

C 
Ø6 x 30mm x4

4

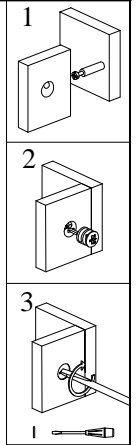
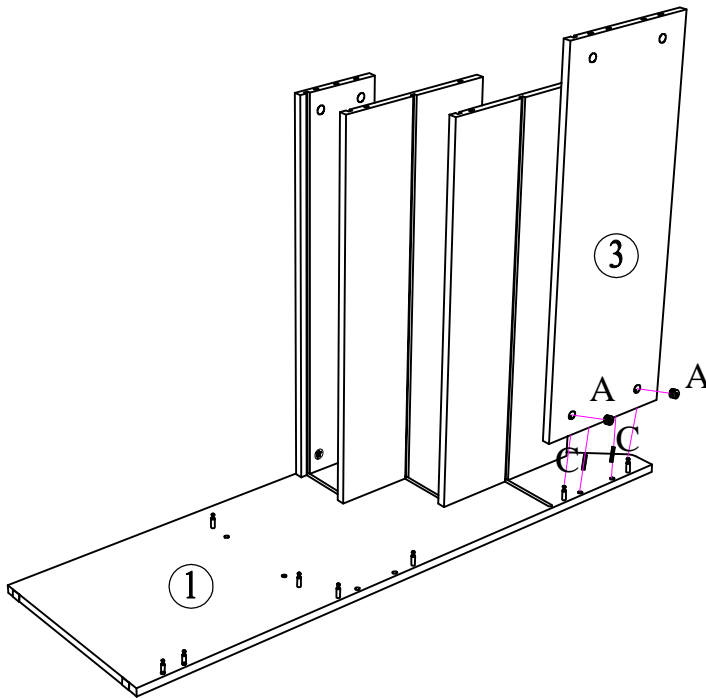



C 
Ø6 x 30mm x2

A 
Ø12x10mm x2

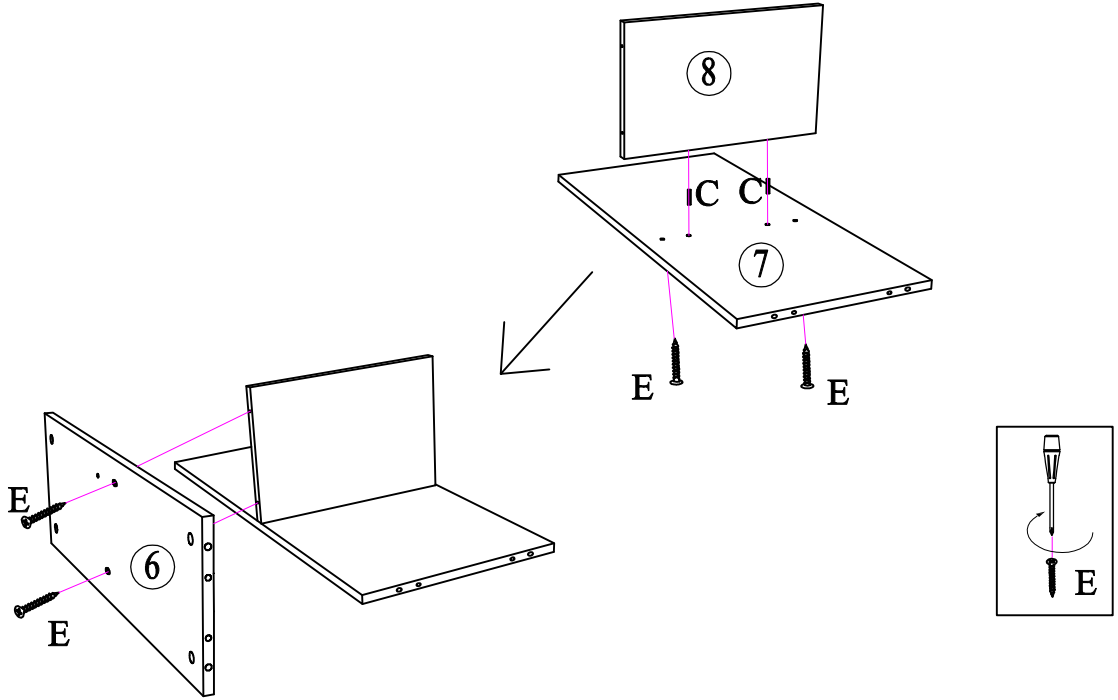

5

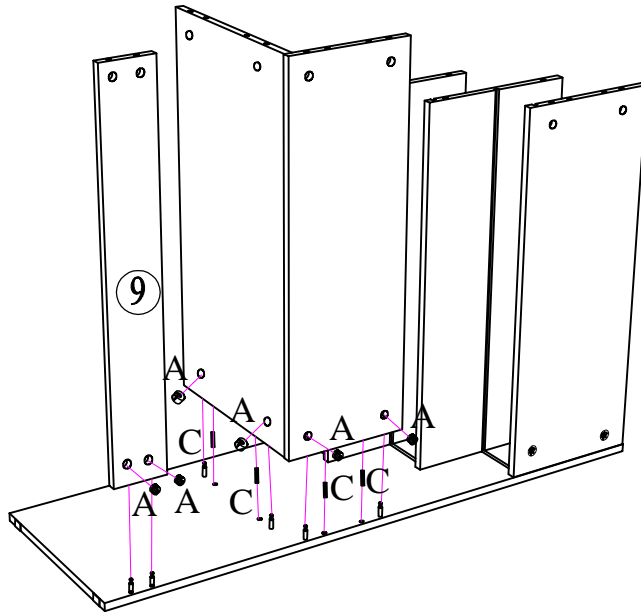

<p>E</p>  <p>M4x 30mm</p> <p>x4</p>	<p>C</p>  <p>Ø6 x 30mm</p> <p>x2</p>
--	---

6





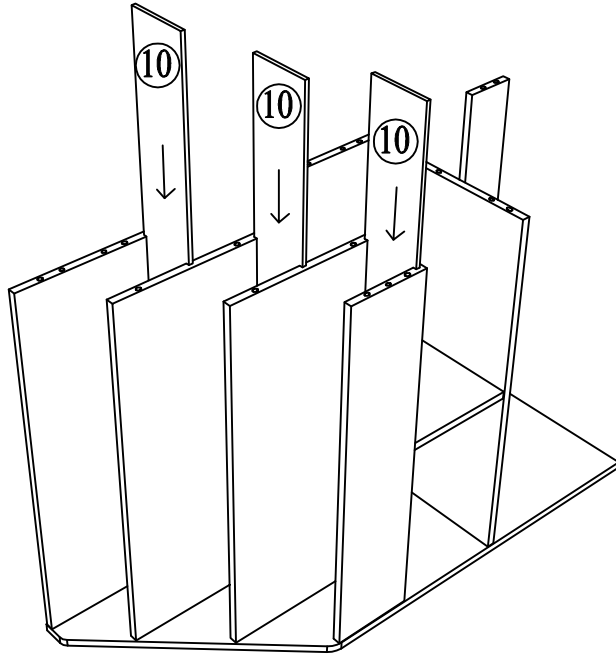

<p>C</p>  <p>Ø6 x 30mm</p> <p>x4</p>	<p>A</p>  <p>Ø12x10mm</p> <p>x6</p>
--	---

7

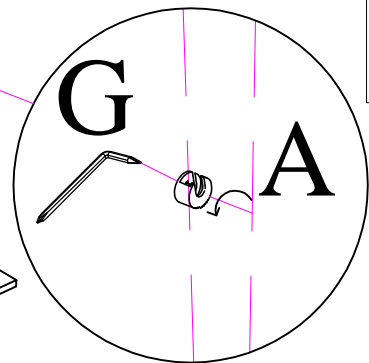
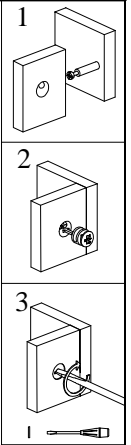
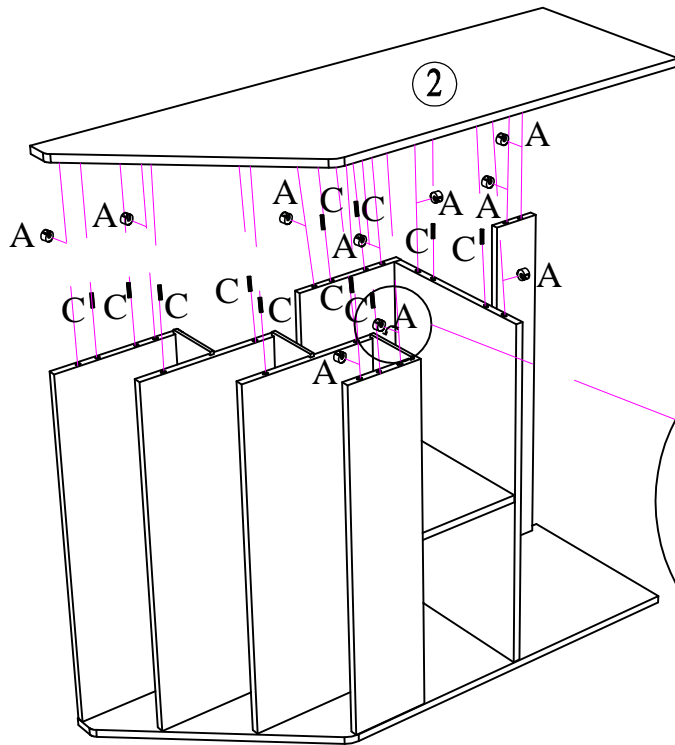

8



<p>G</p>  <p>x1</p>	<p>C</p>  <p>Ø6 x 30mm x11</p>	<p>A</p>  <p>Ø12x10mm x10</p>
---	--	---

9

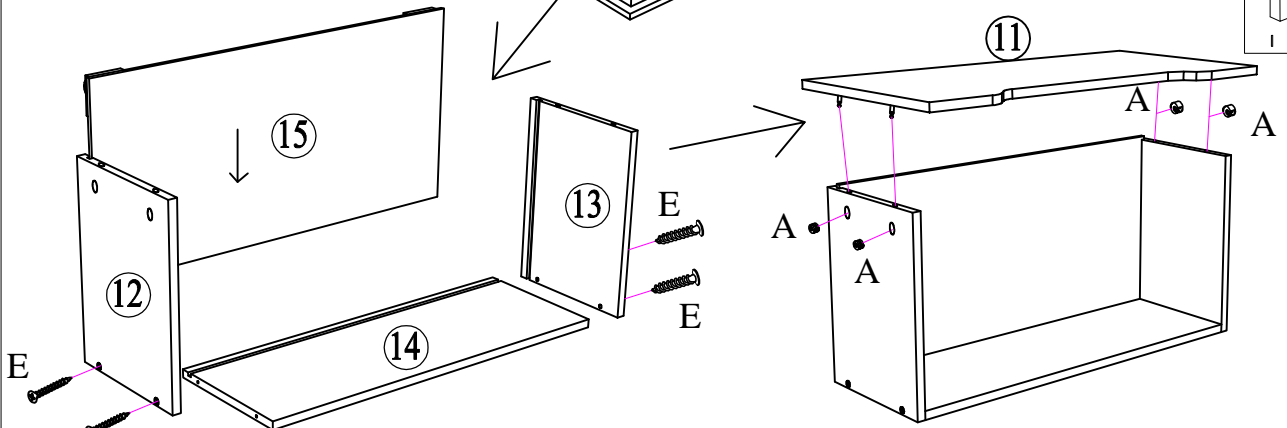
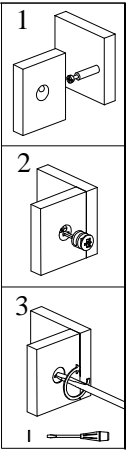
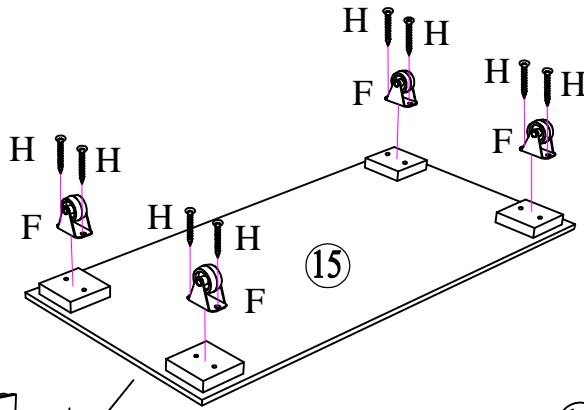
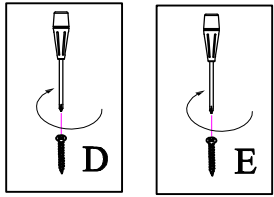

<p>F</p> <p>x4</p>	<p>E</p> <p>M4x 30mm</p> <p>x4</p>	<p>H</p> <p>M3.5x 12mm</p> <p>x8</p>	<p>A</p> <p>Ø12x10mm</p> <p>x4</p>
---------------------------	---	---	---

10

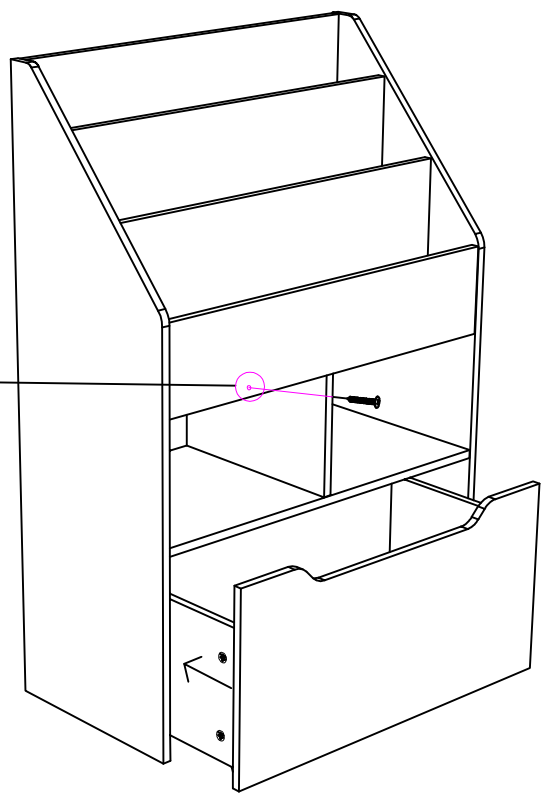
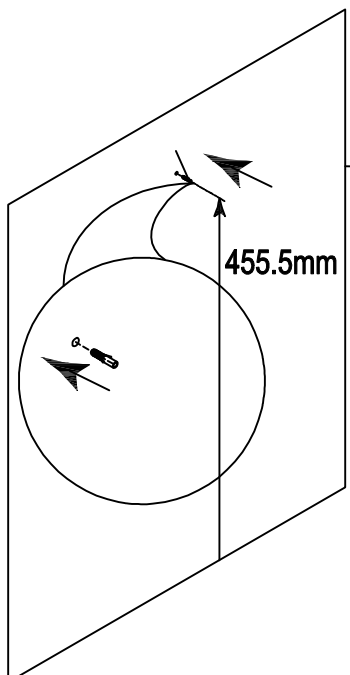

Carton	Reference No.	Quantity
1/1	1	1
1/1	2	1
1/1	3	1
1/1	4	2
1/1	5	1
1/1	6	1
1/1	7	1
1/1	8	1
1/1	9	1
1/1	10	3
1/1	11	1
1/1	12	1
1/1	13	1
1/1	14	1
1/1	15	1
1/1	Accessories	1