

shoe cabinet

Product ID. 7AE3Y

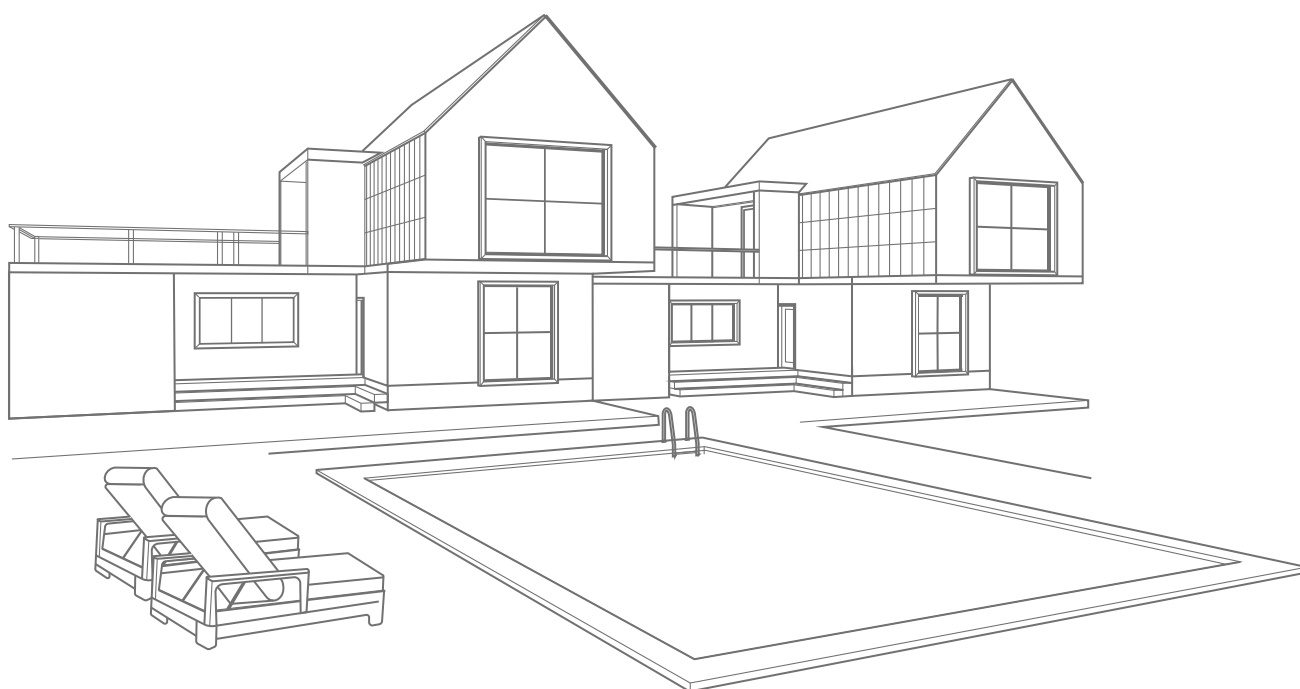

Scan for Support
support@garvee.com







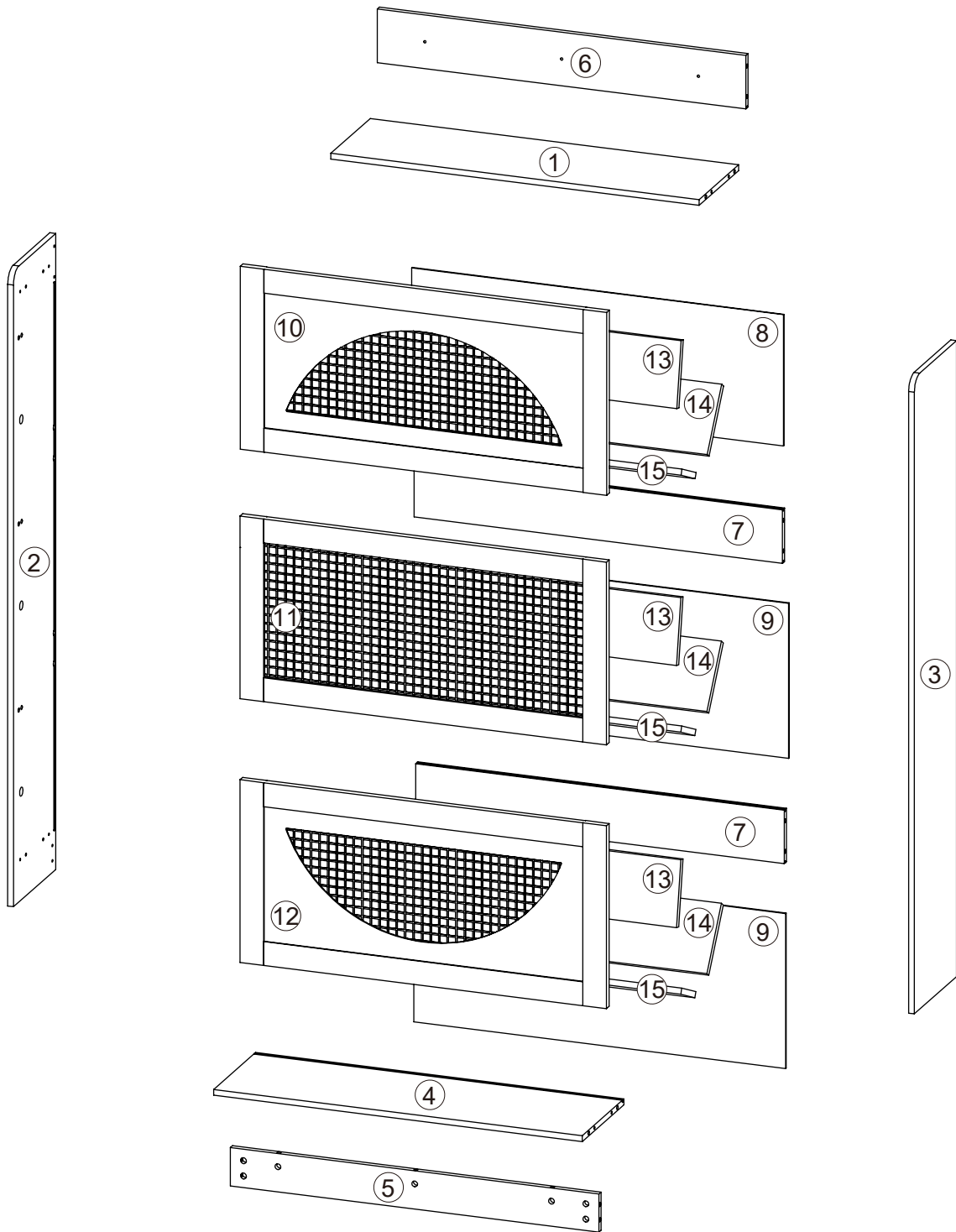

Distributed by
GARVEE.com

V260605REP2

BOARD IDENTIFICATION

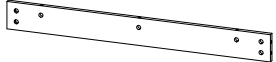
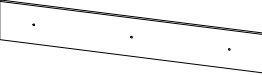
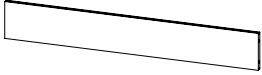
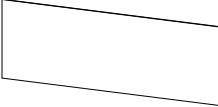
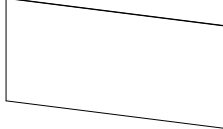
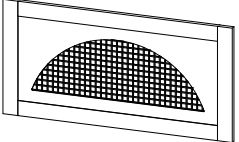
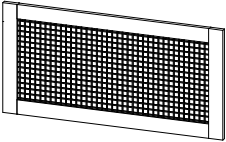
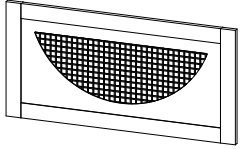
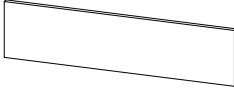

BOARD IDENTIFICATION

				
① × 1	② × 1	③ × 1	④ × 1	⑤ × 1
				
⑥ × 1	⑦ × 2	⑧ × 1	⑨ × 2	⑩ × 1
				
⑪ × 1	⑫ × 1	⑬ × 3	⑭ × 3	⑮ × 3
16	17	18	19	20
21	22	23	23	

BOARD IDENTIFICATION

Installation of Eccentric Wheel Nut Set

1

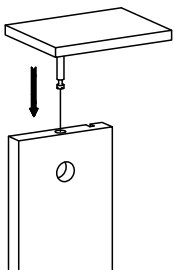

Screw the end of cambolt on the board, find the corresponding board and insert the other end.

2

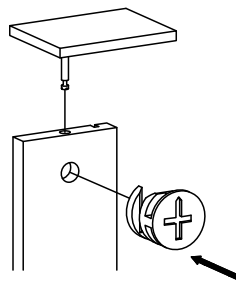

Stuff the camlock into the round hole. The arrow points to the cambolt.

3

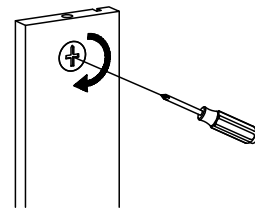

Turn clockwise about 180° to lock the plate.

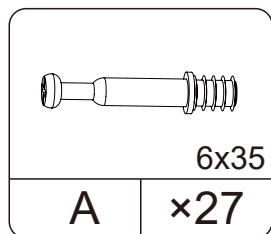

Cam bolt

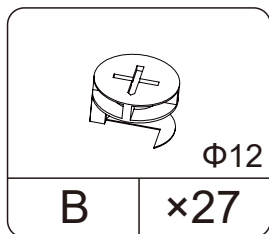

Cam lock

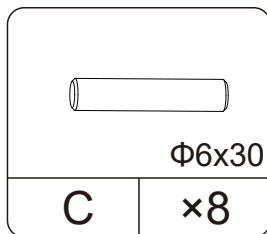

Wood dowel

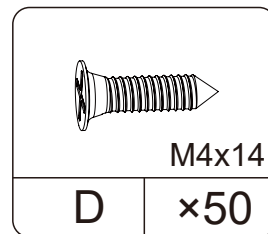

Screws

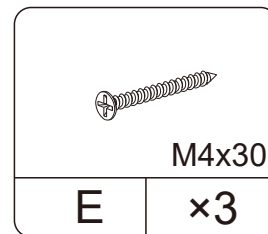

Screws

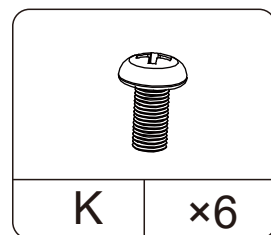
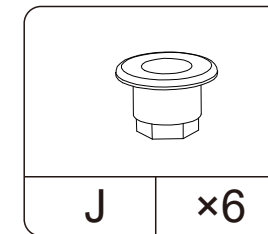
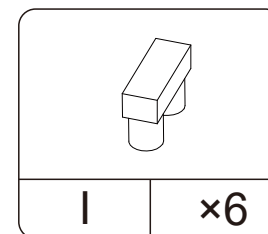
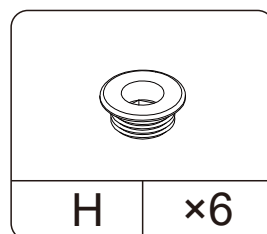
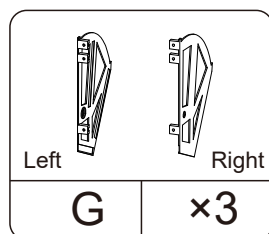
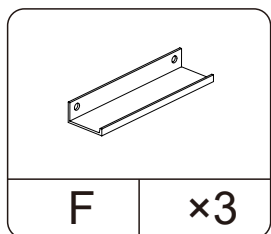

Screws

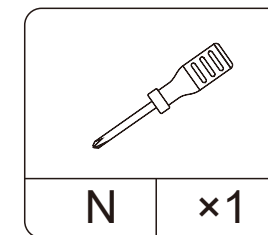
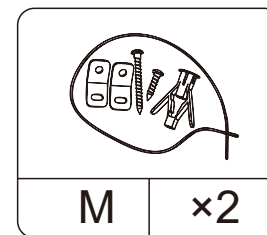
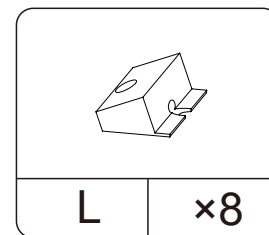

INSTALLATION STEPS

STEP1:

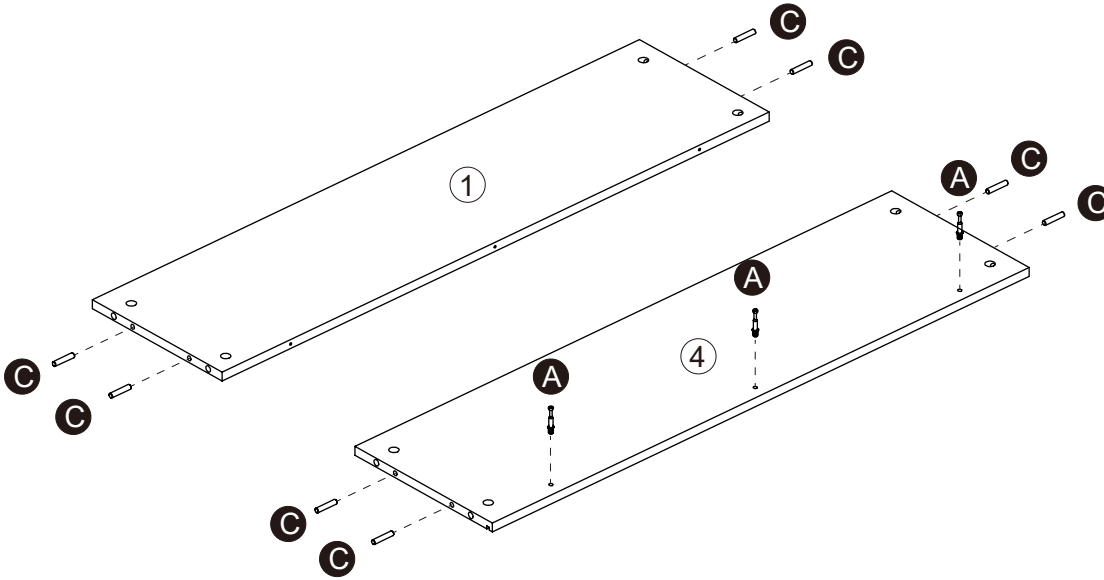
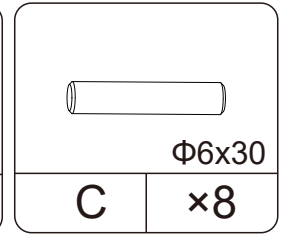
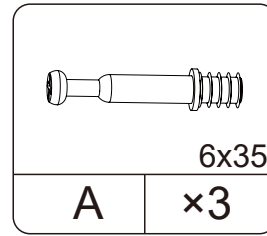

STEP2:

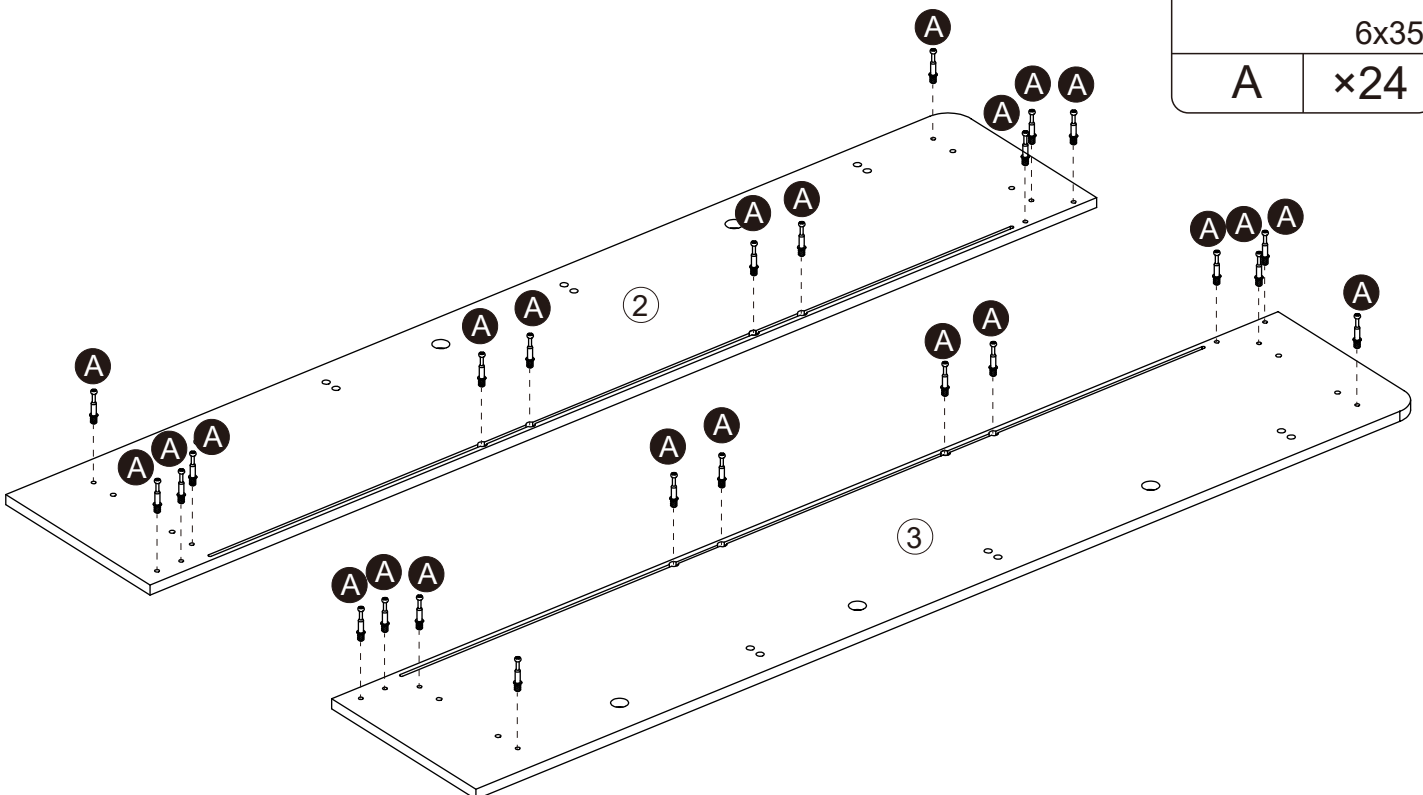
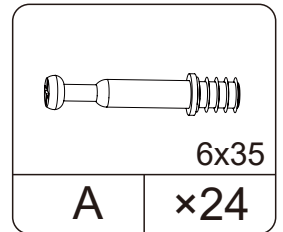

INSTALLATION STEPS

STEP3:

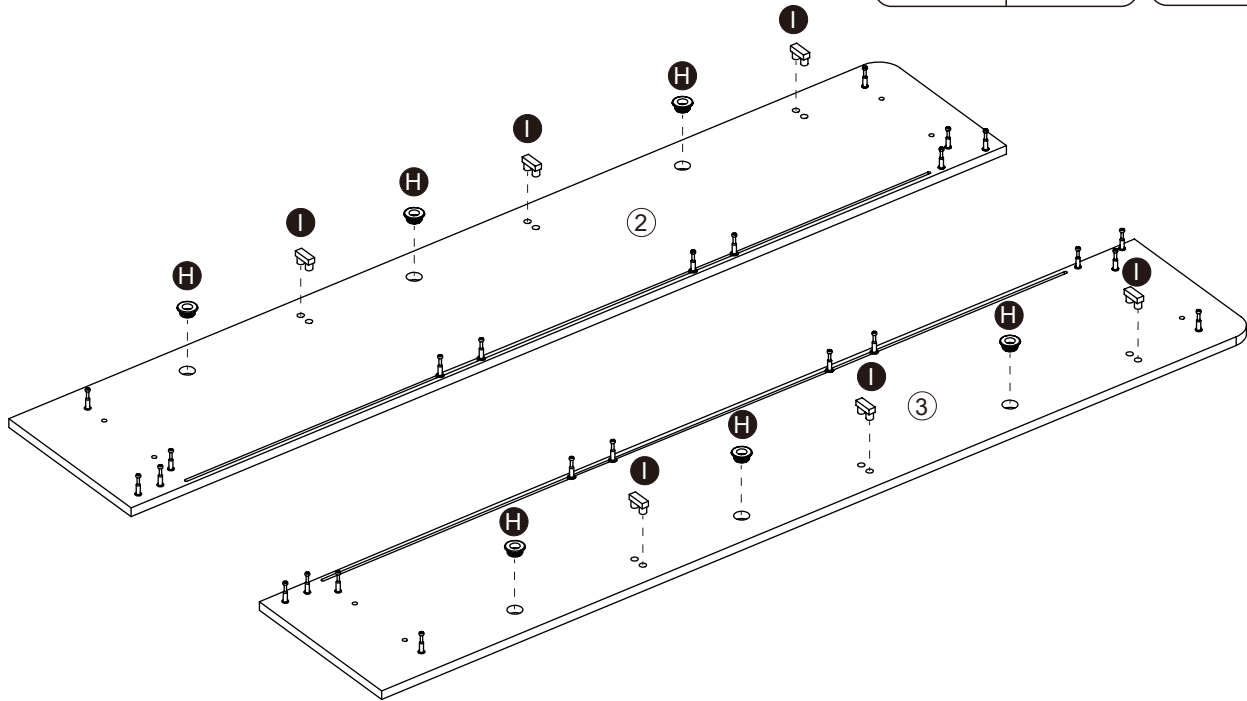
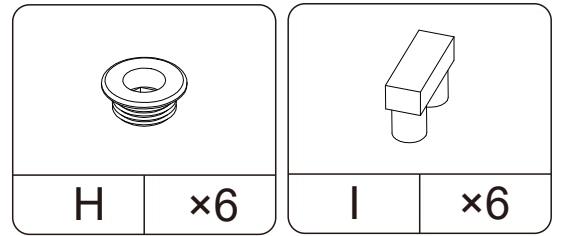

STEP4:

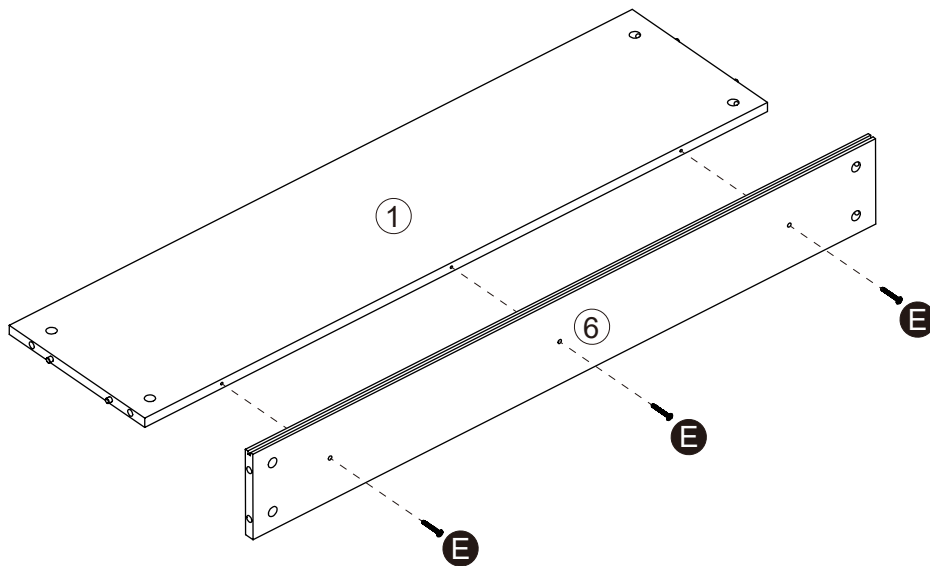
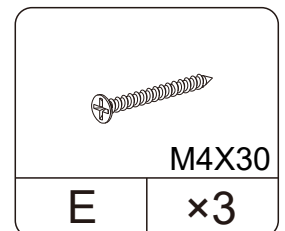

INSTALLATION STEPS

STEP5:

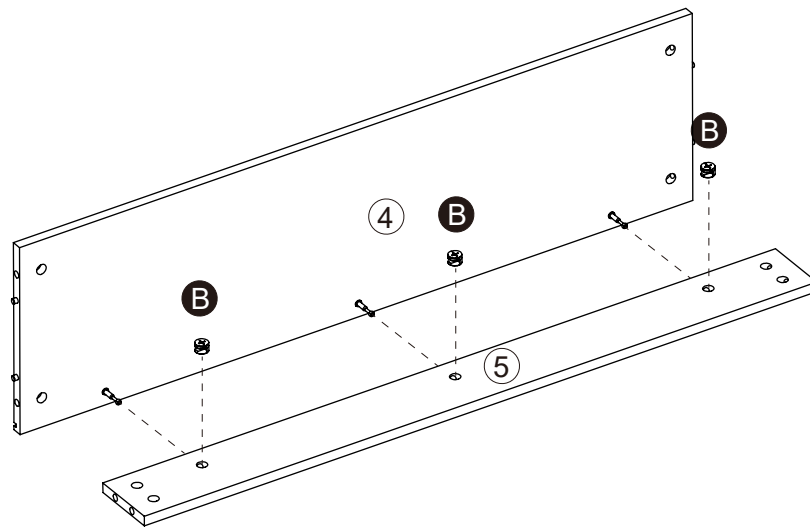
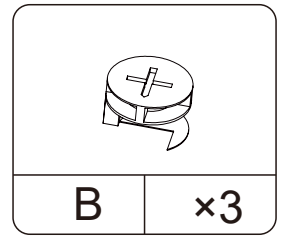

STEP6:

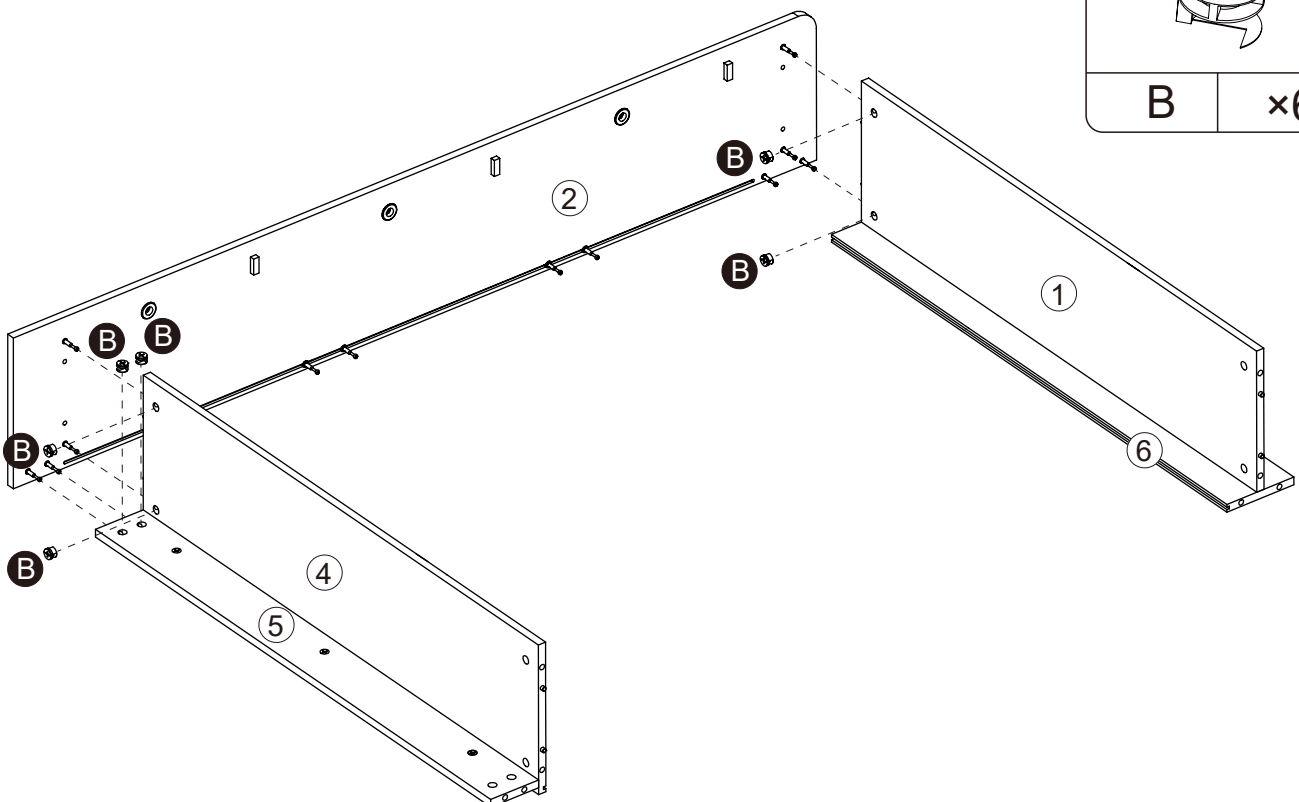
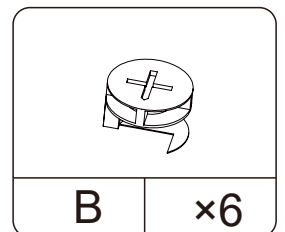

INSTALLATION STEPS

STEP7:

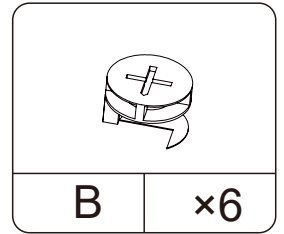
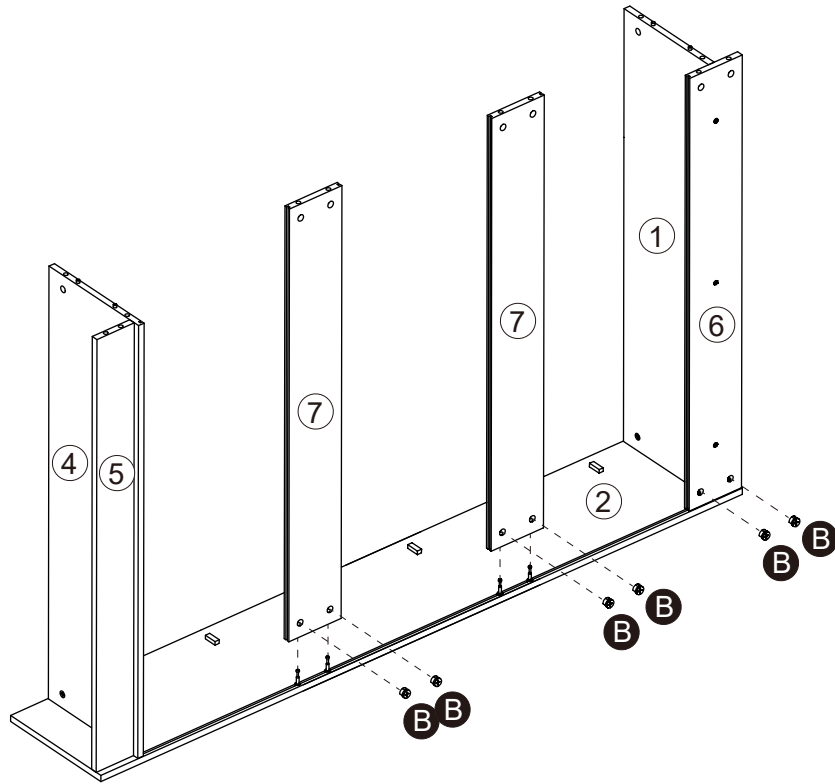

STEP8:

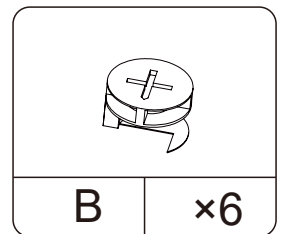
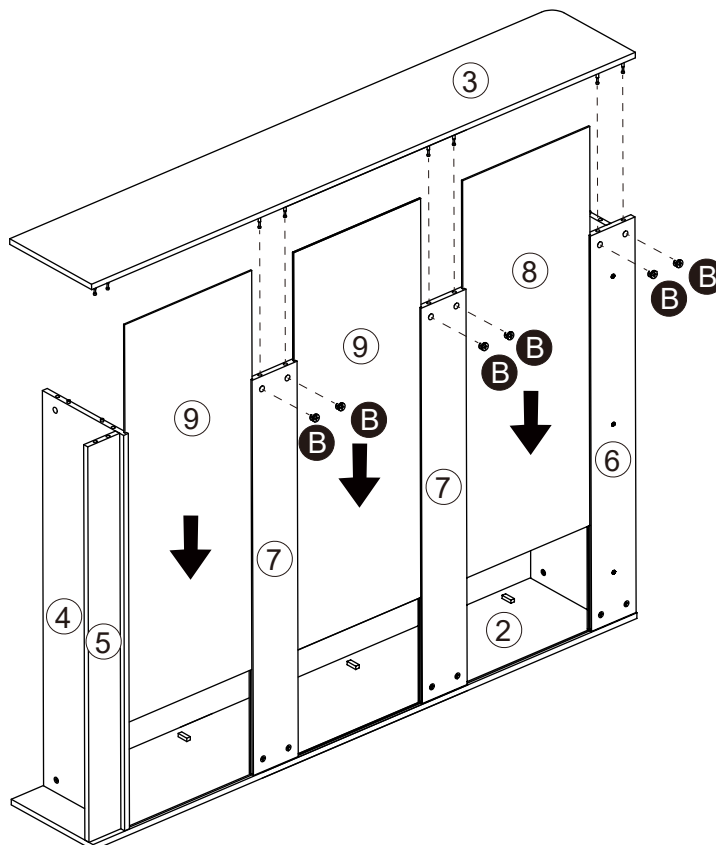

INSTALLATION STEPS

STEP9:

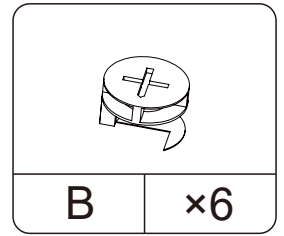
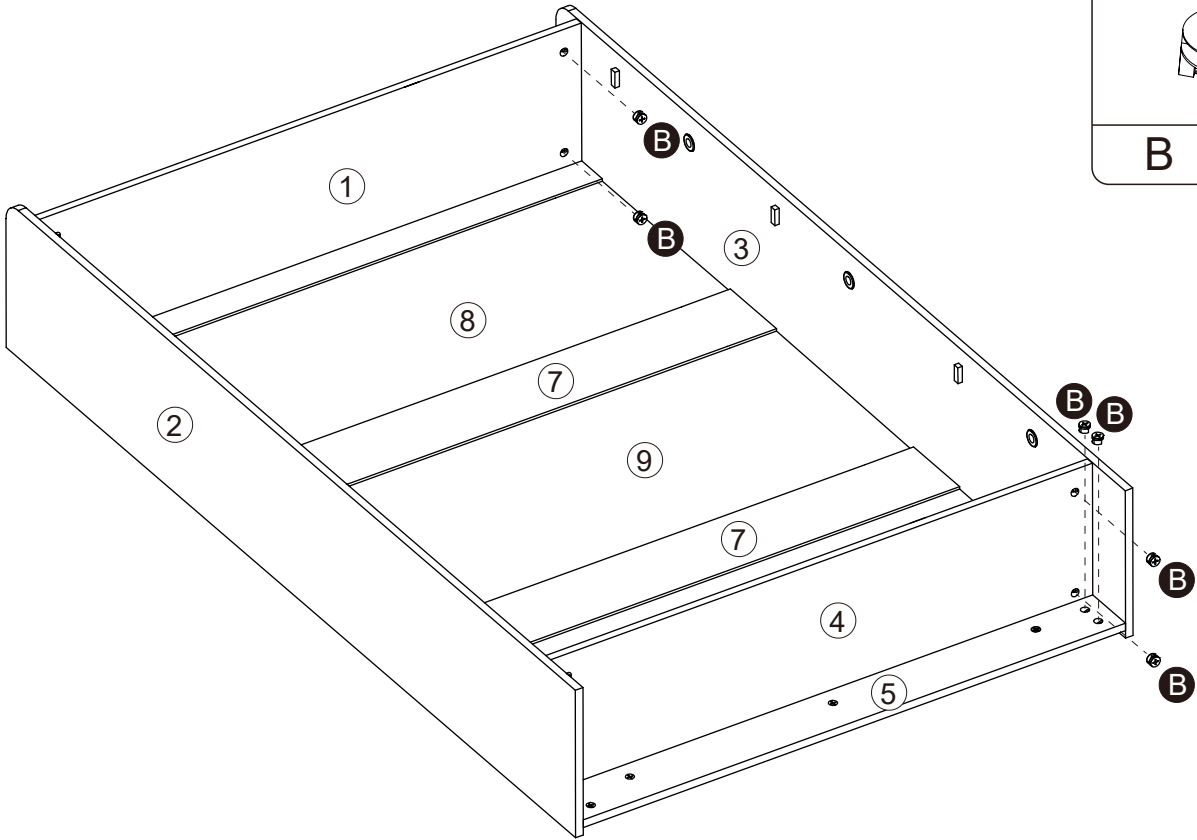

STEP10:

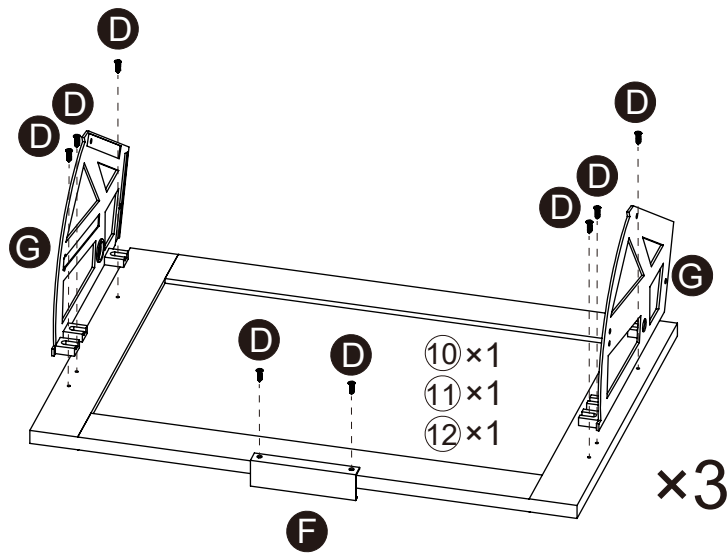
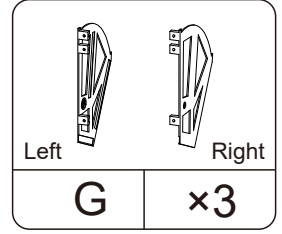
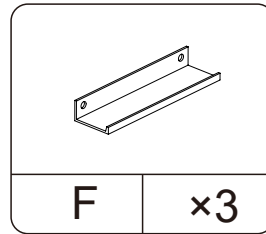
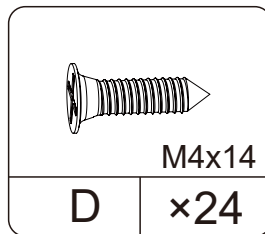

INSTALLATION STEPS

STEP11:

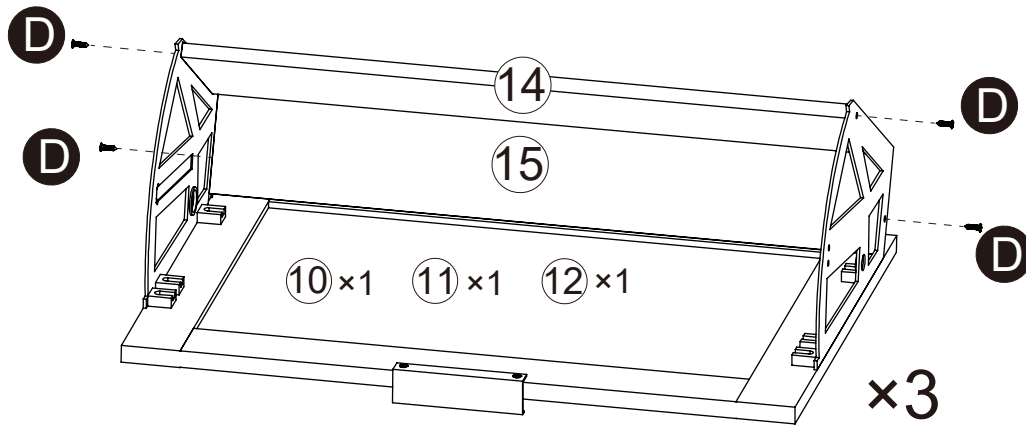
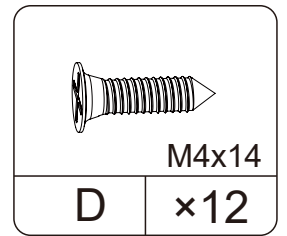

STEP12:

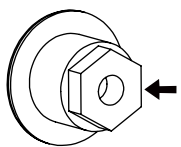

hexagon of
Part J

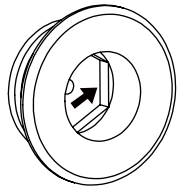

hexagonal groove
of Part H

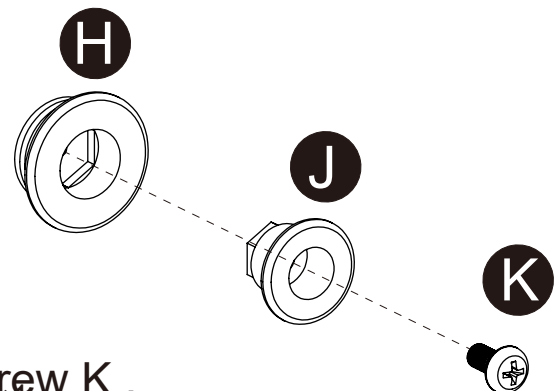
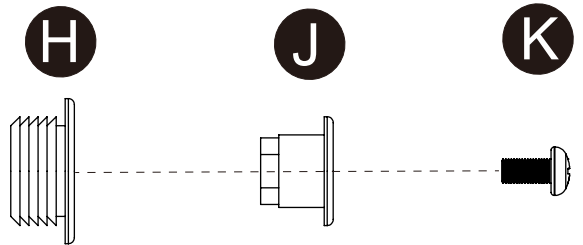

NOTICE:

Before tighten Part H and Part J with Screw K ,
Part H and Part J must be matched properly ,
the hexagon of Part J must be correctly
inserted into the hexagonal groove of Part H

INSTALLATION STEPS

STEP13:

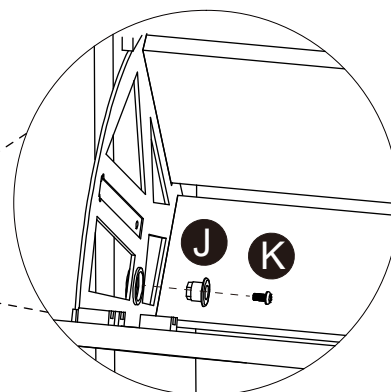
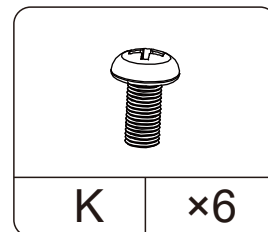
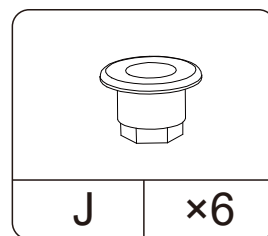
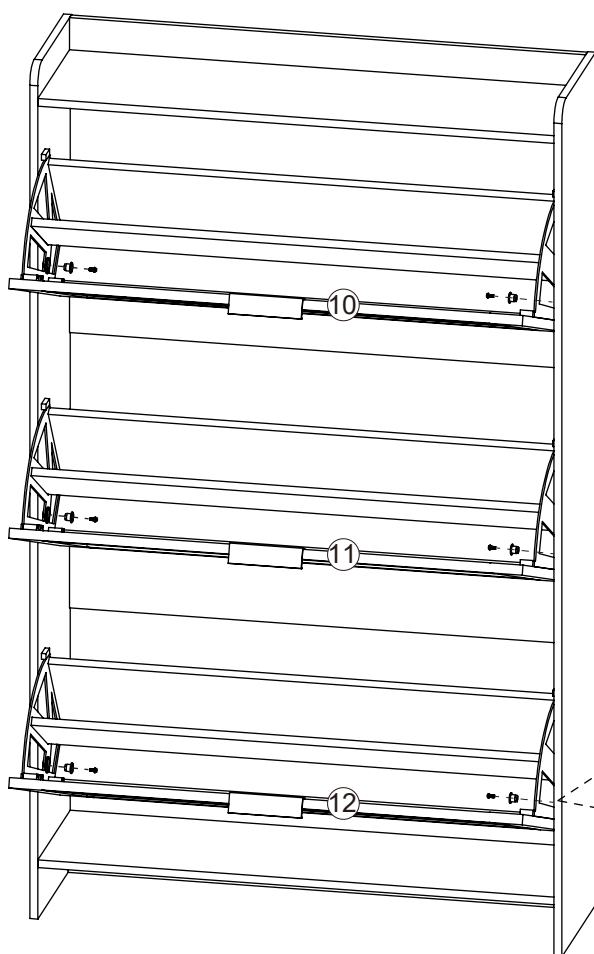

STEP14:

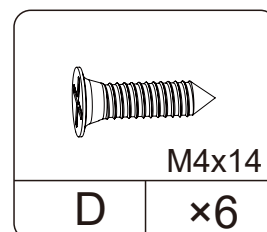
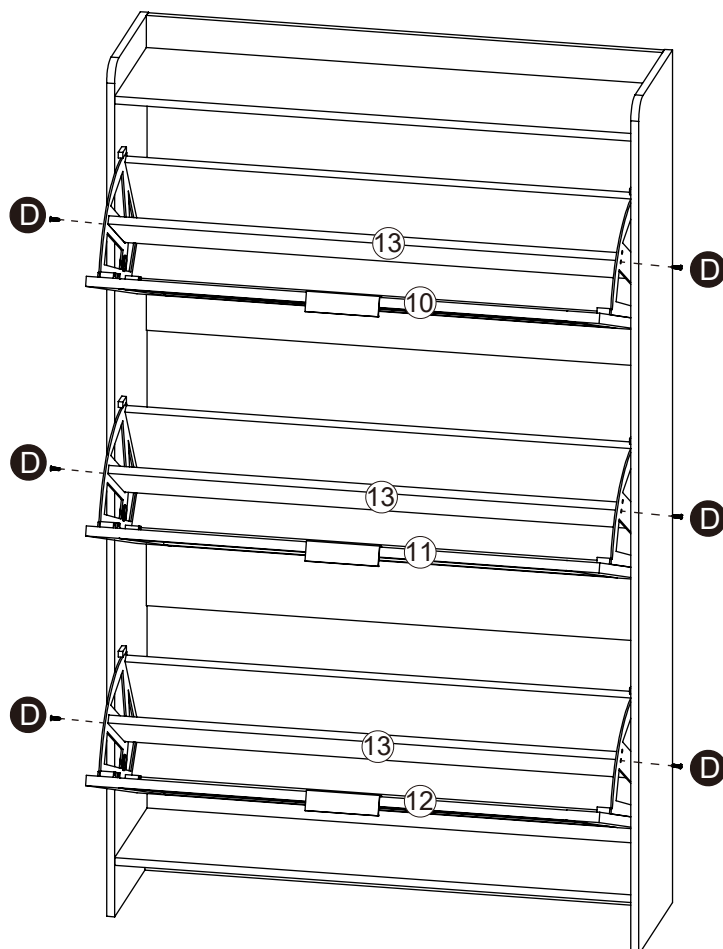

INSTALLATION STEPS

STEP15:

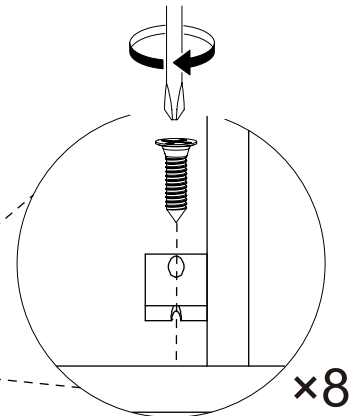
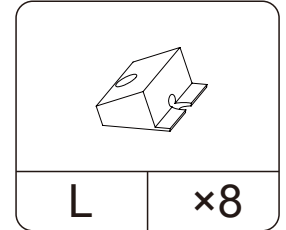
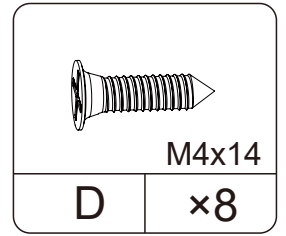
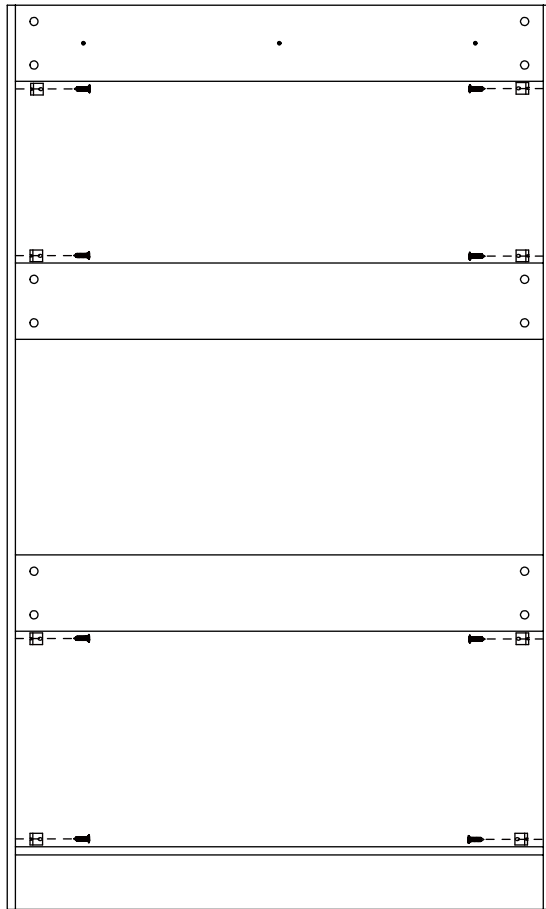

STEP16:

- ① Drill a hole in the solid wall (Wood wall or Concrete wall) :
using a 0.41~0.43 inches (10.5~11mm) drill bit.

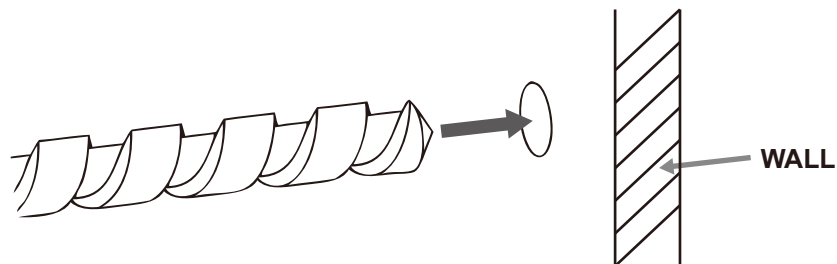
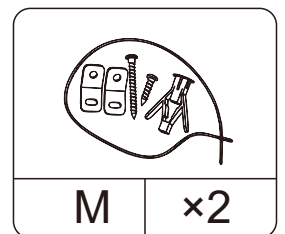

②

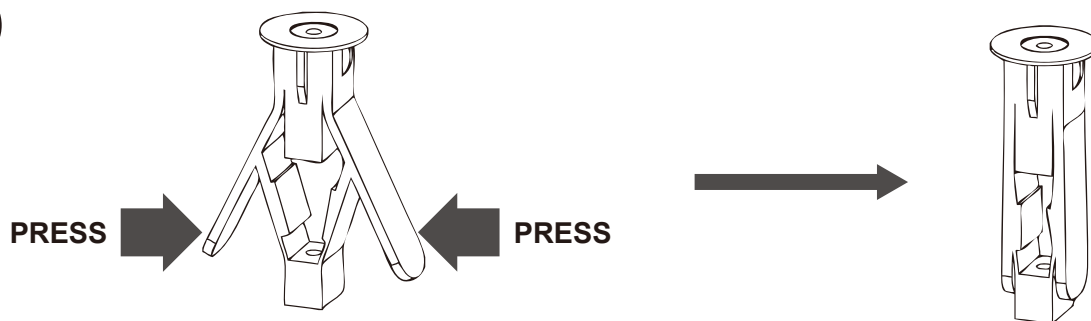

INSTALLATION STEPS

3

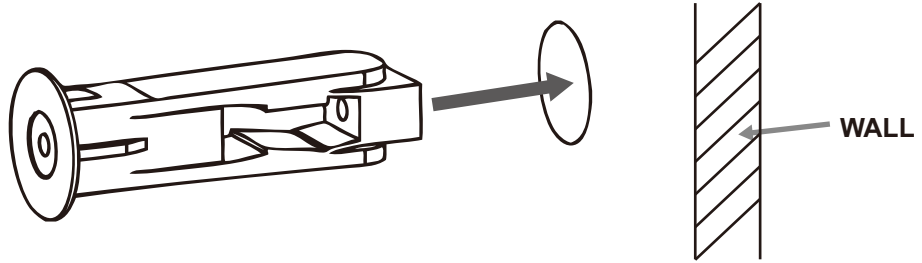

4

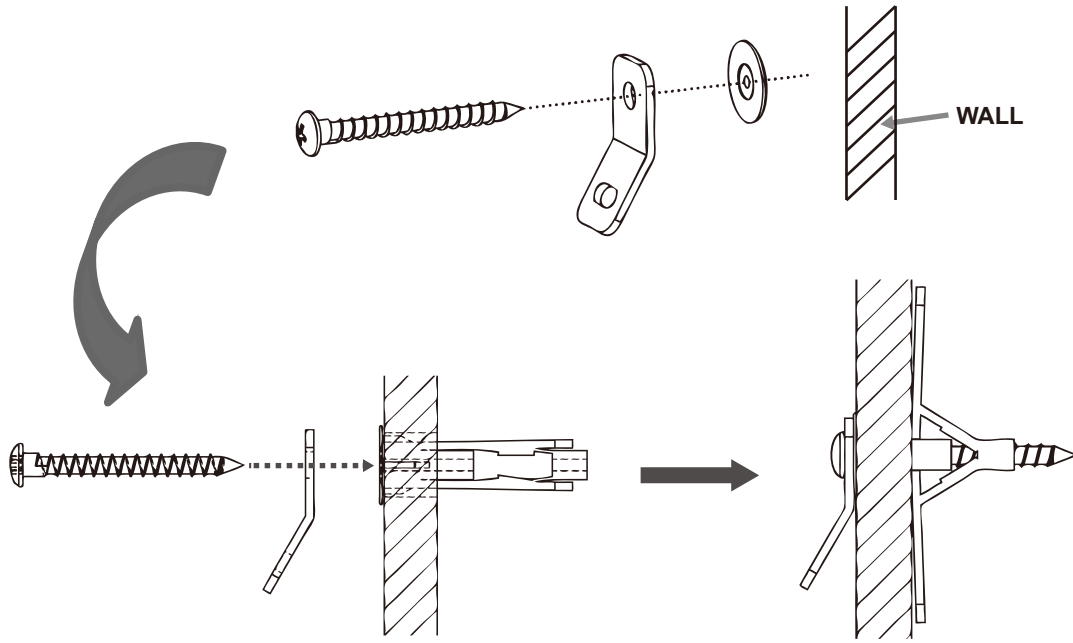

5

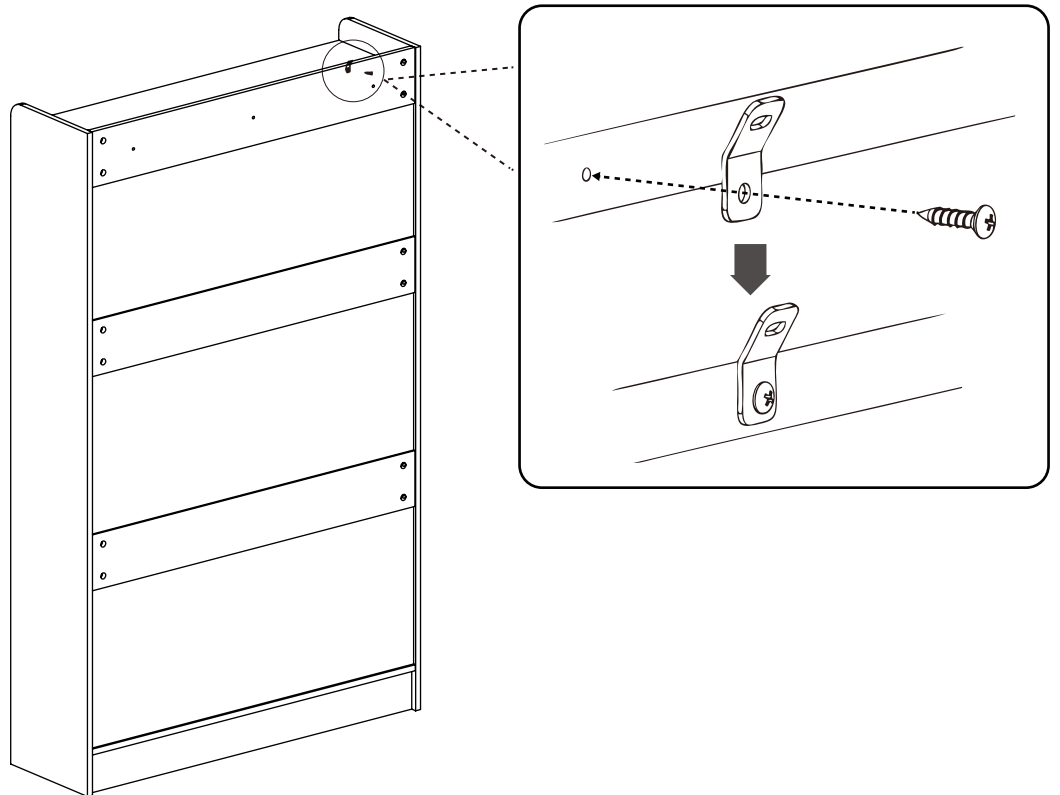

INSTALLATION STEPS

6

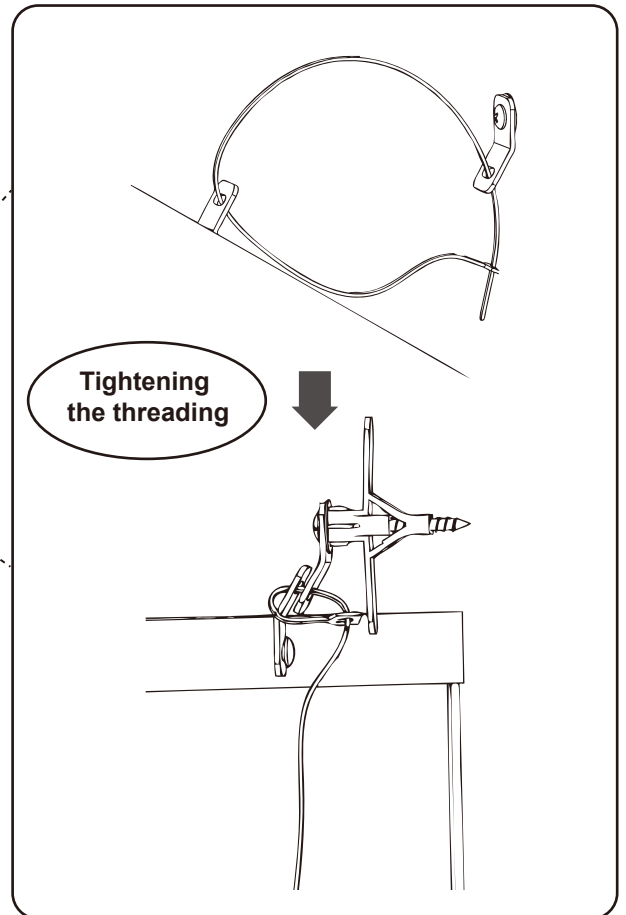
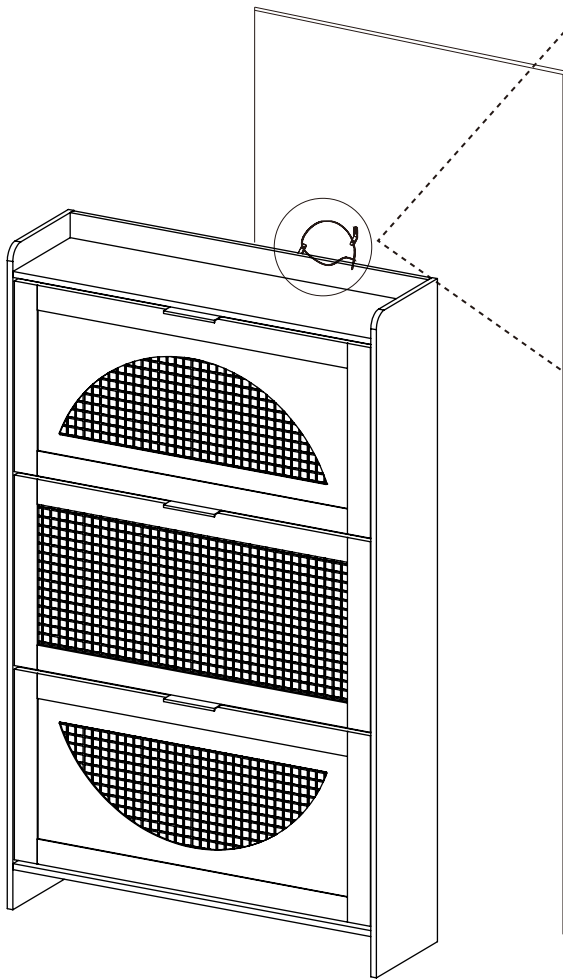

Thank you for purchasing our products. Please contact us if you have difficulty with assembly or need replacement parts. Our customer service is here to assist you. Please attach your User Name and Order ID so that we can assist you better. support@garvee.com

GARVEE
support@garvee.com